

# Datasheet Integrated Sensor

## Type HIM Jx2 Fx Gx



### Features and Benefits

- Small size, low cost, integrated ASIC with analog outputs
- 4-pin metal housing TO-46 / TO-18
- Operating range 2.7V to 5.5V , -40°C to 120°C
- Sensor gain preset to 4300 or 2150
- Integrated linear temperature reference with a sensitivity of typical 16mV/°C
- Large variety of available filter types for different application

### Ordering Information

- HIM -> Heimann thermopile sensor and ASIC in a TO46 housing  
 Jx2 -> „J” standard cap TO46 ; „x” sensor chip (list) ; „2” ASIC STP1  
 Fx -> „x” application-specific filter type (list)  
 Gx -> „x” hardwired sensor gain preset G2150 or G4300

<b>Sensor Chip Selection</b>		
<i>Parameter</i>	<i>Sensor chip "1"</i>	<i>Sensor chip "1C"</i>
Absorbing area	0.61x 0.61mm <sup>2</sup>	0.76x 0.76mm <sup>2</sup>
Sensitivity	50 V/W	46 V/W
Voltage response	19 Vmm <sup>2</sup> /W	27 Vmm <sup>2</sup> /W
Resistance	85 kOhm	85 kOhm
Time constant	5ms	6ms
<b>Filter Selection</b>		
<i>Filter Type</i>	<i>Application</i>	<i>Specification</i>
F4.26-180	CO2 gas detection	NBP CWL 4.26µm HPB 180nm
F4.27-90	CO2 gas detection	NBP CWL 4.27µm HPB 90nm
F4.43-60	CO2 gas detection	NBP CWL 4.43µm HPB 60nm
F4.64-180	CO gas detection	NBP CWL 4.64µm HPB 180nm
F3.30-160	HC gas detection	NBP CWL 3.30µm HPB 160nm
F3.37-190	HC gas detection	NBP CWL 3.375µm HPB 190nm
F3.91-90	gas reference	NBP CWL 3.91µm HPB 90nm
F5.5	temperature detection	LWP Cut On 5.5µm
F8-14	temperature detection	BP HPP 8µm to 14µm

Please contact Heimann customer service for special filter requirements.

# Datasheet Integrated Sensor

## Type HIM Jx2 Fx Gx



### Operating Conditions

Parameter	Typical Value	Unit	Condition
Supply voltage VDD	(2.7).. 3 .. 5..(5.5)	V	+Vs
Supply voltage VSS	0	V	-Vs , Ground
Supply current	1	mA	Without load
Open loop gain	90	dB	
Low pass frequency	240	Hz	ASIC
PSRR	>40	dB	
Output voltage range	0.15 .. (VDD-0.15)	V	
Start up time after POR	Max. 0.5	sec	Electrical start up
Noise voltage input related	45	nV/ $\sqrt{Hz}$	Output TPO; Sensor + ASIC
Zero input sensor signal	1.25	V	Output TPO
Sensor gain preset	4300 or 2150	V/V	Output TPO ; hardwired
Temp. ref. voltage at 25°C	1.45	V	Output TRO
Sensitivity temp. reference	16	mV/°C	Linear ; Output TRO
Field of view	70	degree	Sensor chip TP1
Operating temperature	-40.. 120	°C	

### Pin Assignment

Pin No	Symbol	Description
1	VDD	Positive supply voltage
2	TPO	Amplified thermopile sensor output voltage
3	TRO	Analog temperature reference output voltage
4	VSS	Negative supply voltage / Ground (0V)

bottom view

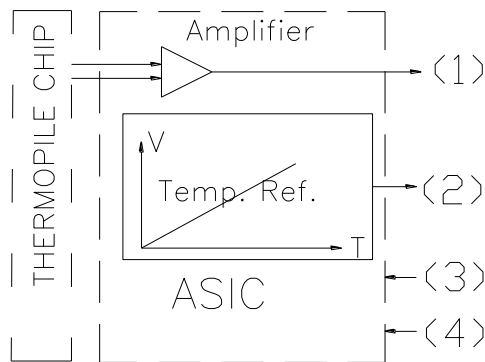
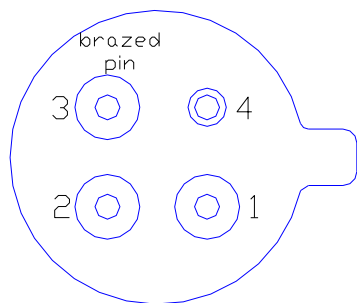

# Datasheet Integrated Sensor

## Type HIM Jx2 Fx Gx



### Dimensions

#### HIM J12 ..

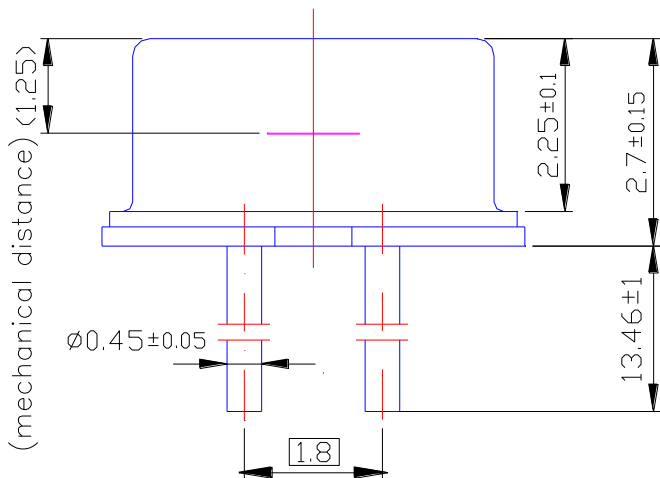
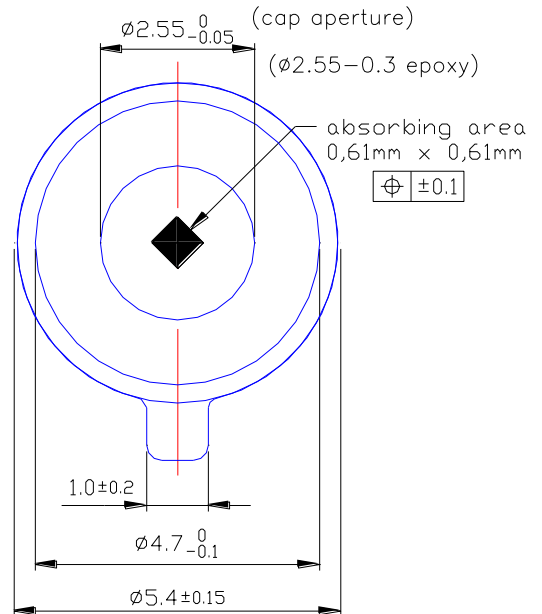
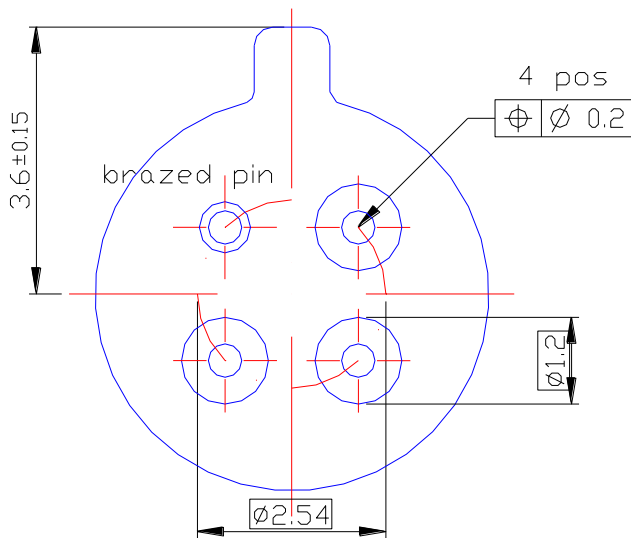

#### HIM J1C2 ..

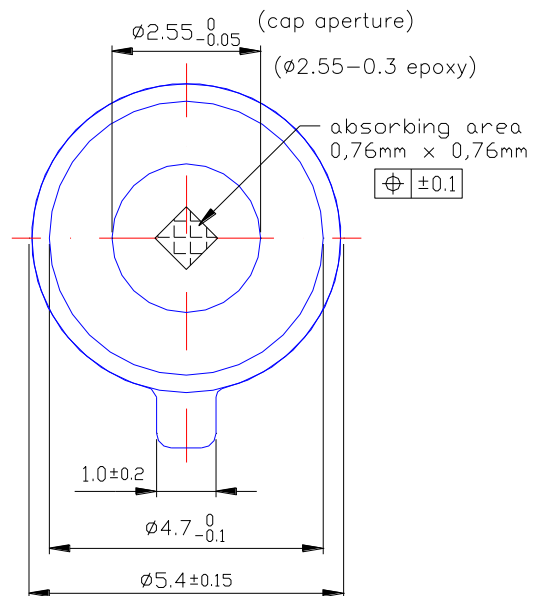

# Datasheet Integrated Sensor

## Type HIM Jx2 Fx Gx



### Application Hints

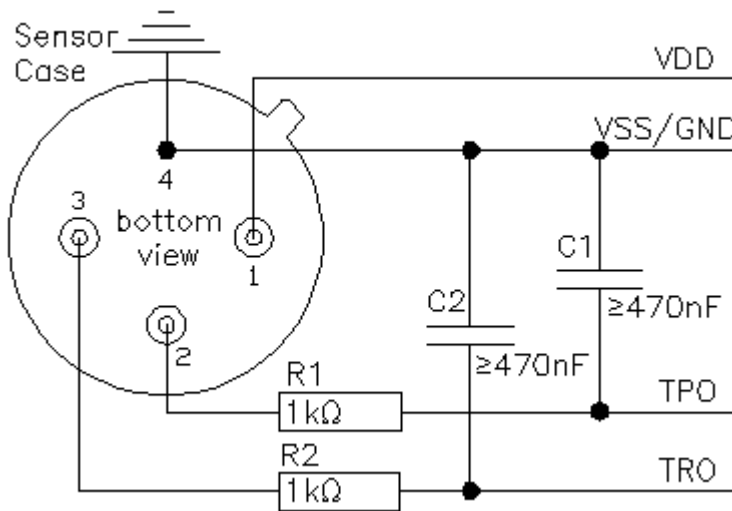

#### Output Signal

Due to use of chopper-stabilized amplifiers residual ripples of chopping frequency can interfere on the outputs in the range of 20kHz.

Software filtering or low pass filtering can be used to suppress the ripple.

Sample circuitry for simple RC low pass filtering (at resistive loads of >1MΩ) is shown in alongside picture.

#### ESD and SEL Avoidance

Integrated sensors can be damaged by electrostatic discharges and single event latch-up. Please take appropriate precautions for the handling to avoid such events. To prevent thermal damages by latch-up condition, no voltage greater than 0.3V beyond supply voltage should be applied to any pin. Supply voltages must be established before or at least at same time before any other connections are applied.

Stresses above the absolute maximum ratings may cause damages to the device.

#### Cleaning and Soldering Advise

Do not expose the sensors to aggressive detergents. Windows may be cleaned with alcohol and cotton swab.

Wave soldering may be applied by a maximum temperature of 280° C for a dwell time less than 10s. Avoid solder exposure to the top and the window of the detector. For hand soldering the maximum applicable temperature is 350° C for a dwell time less than 3s. The minimum distance between the housing body and the liquid solder should be for 280° C at least 0.6mm and for 350° C at least 1.5mm.

### Liability

Changes or modifications at the product which haven't influence to the performance and/or quality of the device haven't to be announced to the customers in advance. Customers are requested to consult with Heimann Sensor representatives before the use of Heimann Sensor products in special applications where failure or abnormal operation may directly affect human lives or cause physical injury or property damage. The company or their representatives will not be responsible for damage arising from such use without prior approval.