



HTPA 8x8, 16x16, 32x31, 64x62 Thermopile Array with Ge-Lens

Heimann offers world new fully monolithic thermopile sensor arrays. This allows the measurement of temperature distribution of the environment, where very high resolutions are not necessary, such as person detection, surveillance of temperature critical surfaces, hotspot or fire detection, energy management and security applications. Other applications can be found in industrial process control and air condition control.

The benefits of this technology are low costs, the very small power consumption, small size, as well as the high sensitivity of the system. The larger arrays fit in a TO8 can and the 8x8 array even in a TO39 housing, which provides small dimensions and a reliable mechanical assembly.

Principal Schematic:

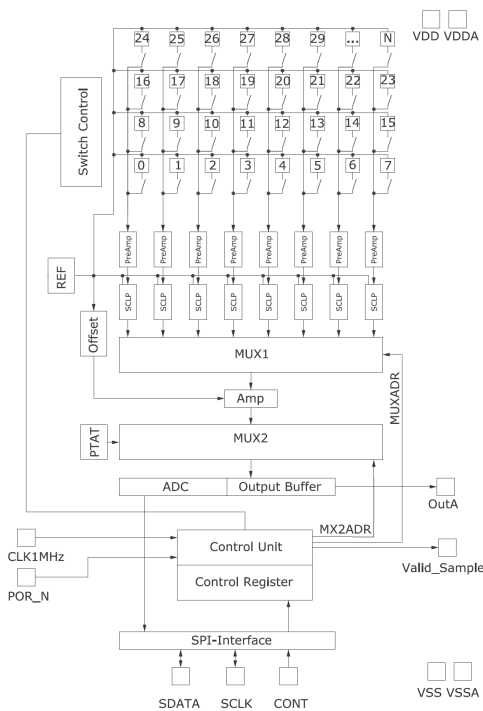

The built-in lens can be varied (f = 3mm, 4mm, 7mm or 10mm).

HTPA 8x8 L7 TO39

(single Ge-Lens, f=7mm)

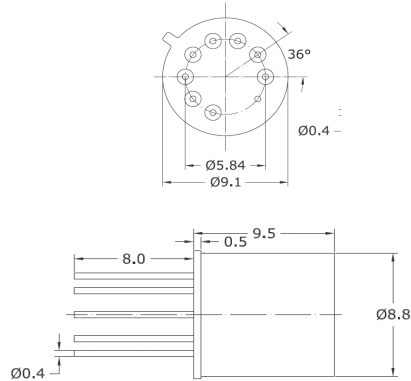

HTPA 32x31 L10 / HTPA 64x62 L10

(dual lens, f=10mm, f/# 1.0 or 0.8)

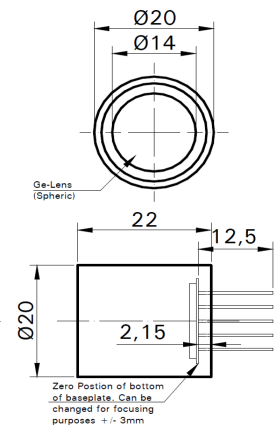

HTPA32x31L7 (single Ge-Lens, f=7mm)

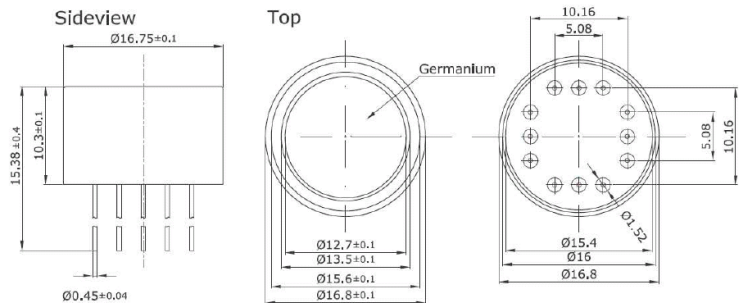

HTPA series parameter overview

Parameter	HTPA8x8	HTPA16x16	HTPA32x31	HTPA64x62	Unit
Technology	n-poly/p-poly Si	n-poly/p-poly Si	n-poly/p-poly Si	n-poly/p-poly Si	
Sensitivity (without optics/filter)	approx. 60	approx. 40	approx. 40	250...1500	V/W
NETD @1Hz and 100°C	<0.1	0,1	0,1	TBD	K
Total noise	70	50	50	50	nV/sqrt(Hz)
Pixel time constant	<4	<4	<4	5...80	ms
Internal ADC	12	12	/	/	bit
Interface type	SPI	SPI	SPI	SPI	
Analogous Out	Yes	Yes	Yes	Yes	
2 Point selectable gains	2640/7920x	2640/7920x	2640/7920x	2640/7920x	
Pitch	300	220	220	110	µm
Absorber size	220x220	150x150	150x150	60x60	µm ²
Frames per second	70	20	>20	approx. 5-10	Hz
Supply voltage	5	5	5	5	V
Sensitive Elements	64	256	992	3968	

Modifications reserved Rev.03/ 12.05.2010

HEIMANN Sensor GmbH
Grenzstr. 22
D-01109 Dresden, Germany

Contact / Customer Support
Phone 49 (0) 6123 60 50 30
Fax 49 (0) 6123 60 50 39

Internet
www.heimannsensor.com
e-mail: info@heimannsensor.com