

CANbus • SAE J1939

Ranges: 0-90° to 0-50 Turns

Industrial Grade

RT9CN

Specification Summary:

GENERAL

Full Stroke Ranges..... 0-0.25 to 0-50 turns
 Electrical Interface..... CANbus SAE J1939
 Protocol..... Proprietary B
 Accuracy..... ± 0.15 to ± 0.30% full stroke, see ordering information
 Repeatability..... ± 0.02% full stroke
 Resolution..... ± 0.003% full stroke
 Enclosure Material..... powder-painted aluminum or stainless steel
 Sensor..... plastic-hybrid precision potentiometer
 Shaft Loading..... up to 35 lbs. radial and 5 lbs. axial
 Weight, Aluminum (Stainless Steel) Enclosure..... 5 lbs. (10 lbs.), max.

ELECTRICAL

Input Voltage..... 7 - 18 VDC
 Input Current..... 60 mA max.
 Address Setting (Node ID)..... 0..63 set via DIP Switches
 Baud Rate..... 125K, 250K or 500K set via DIP Switches
 Update Rate..... 10 ms. (20 ms. available—*contact factory*)

ENVIRONMENTAL

Environmental Suitability..... NEMA 4/4X/6, IP 67/68
 Operating Temperature..... -40° to 185°F
 Vibration..... up to 10 G's to 2000 Hz maximum

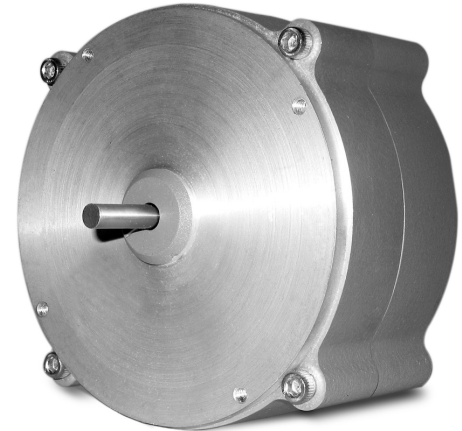

Celesco's model RT9CN communicates rotational position feedback to your PLC via the CANbus SAE J1939 interface. The heart of this sensor is a precision plastic-hybrid position potentiometer which provides a "absolute" position and does not ever have to be reset to a "home" position after a power loss or planned shutdown.

This innovative sensor from Celesco, designed to meet tough NEMA-4 and IP67 environmental standards, is available in full-stroke measurement ranges of 1/4 to 50 turns.

Outline Drawing

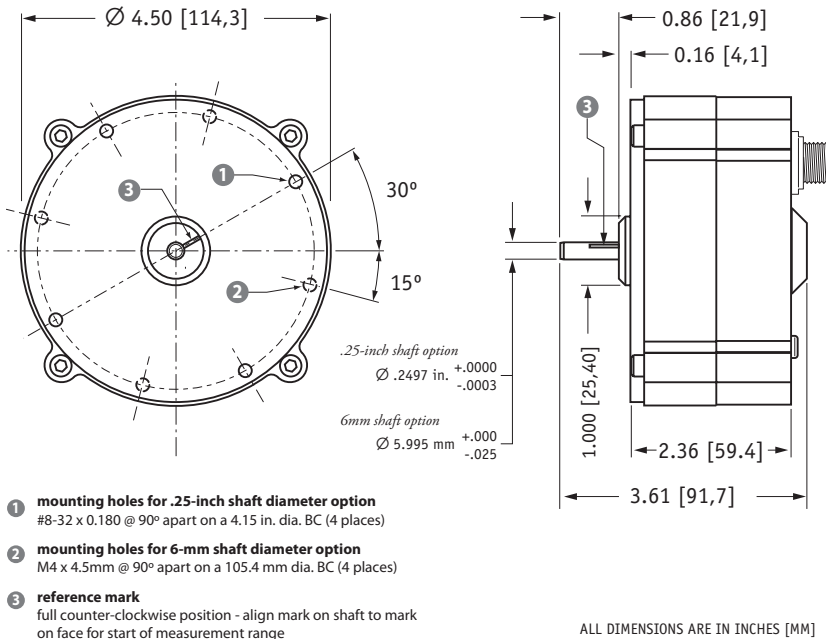

Output Signal

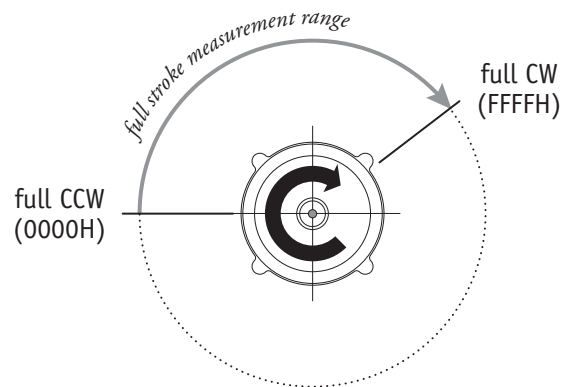

I/O Format and Settings

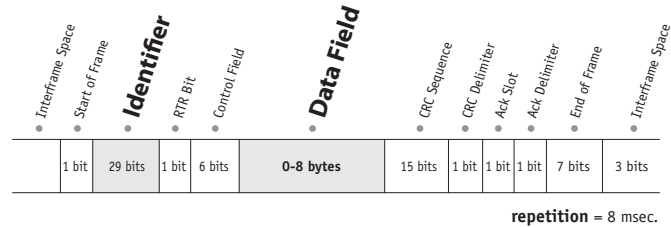

• Identifier

	Message Priority				Future Use				J1939 Reference Proprietary B								Data Field Type*				Not Used		Node ID**									
Example	1	0	0	0	0	0	1	1	1	1	1	1	1	1	1	1	0	1	0	1	0	0	1	1	0	0	1	1	1	1	1	1
Identifier Bit No.	28	27	26	25	24	23	22	21	20	19	18	17	16	15	14	13	12	11	10	9	8	7	6	5	4	3	2	1	0			
Hex Value	0				F				F				5				3				3		F									

*Sensor field data can be factory set to customer specific value. **Customer defined, set via Dips 1-6. Bit values shown for example only, see Address Setting below.

• Data Field

B₀ = LSB current % of measurement range byte
B₁ = MSB current % of measurement range byte
B₂ = LSB current measurement count byte
B₃ = MSB current measurement count byte

B₄ = error flag
B₅ = error flag
B₆ = LSB velocity data byte
B₇ = MSB velocity data byte

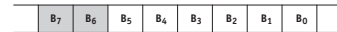
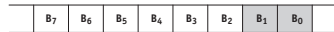
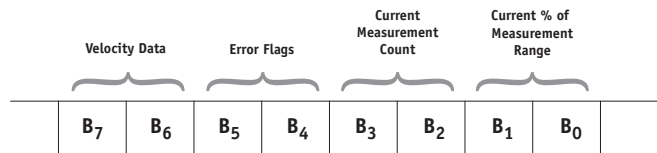

Current Measurement Count

The Current Measurement Count (CMC) is the output data that indicates the present position of the measuring cable. The CMC is a 16-bit value that occupies bytes **B₂** and **B₃** of the data field. **B₂** is the **LSB** (least significant byte) and **B₃** is the **MSB** (most significant byte).

The CMC starts at **0x0000** with the shaft in the full counter-clockwise position (at reference mark) and continues upward to the end of the stroke range stopping at **0xFFFF**. This holds true for all ranges.

Converting CMC to Degrees

If required, the CMC can easily be converted a rotary measurement expressed in degrees instead of simply counts.

This is accomplished by first dividing the CMC by 65,535 (total counts over the range) and then multiplying that value by the FSR:

$$\left(\frac{\text{CMC}}{65,535} \right) \times \text{FSR}$$

Example:

If the full stroke range is **1 turn (360 degrees)** and the current position is **0x0FF2 (4082 Decimal)** then,

$$\left(\frac{4082}{65,535} \right) \times 360 \text{ degrees} = 22.4 \text{ degrees}$$

Current % of Measurement Range

The Current % of Measurement Range is a 2-byte value that expresses the current linear position as a percentage of the entire full stroke range. Resolution is **.1 %** of the full stroke measurement range.

This value starts at **0x0000** at the beginning of the stroke and ends at **0x03E8**.

Example:

Hex	Decimal	Percent
0000	0000	0.0%
0001	0001	0.1%
0002	0002	0.2%
...
03E8	1000	100.0%



Error Flags

0x55 (yellow LED on controller board) indicates that the sensor has begun to travel beyond the calibrated range of the internal position potentiometer.

0xAA (red LED on controller board) indicates that the sensor has moved well beyond the calibrated range of the internal position potentiometer.

If either error flag occurs within the full stroke range of the sensor, the unit should be returned to the factory for repair and recalibration.

Velocity

Data in bytes **B₇** - **B₆** is the change and direction of the CMC (current measurement count) over a 100 msec time period. This data can then be used to calculate velocity and direction in a post processing operation.

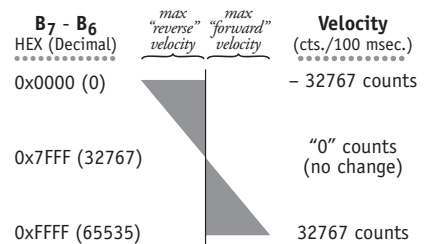

Velocity Calculation

$$\left(\frac{\text{count change} - 32767}{.1 \text{ sec. time period}} \right) \times \left(\frac{\text{full stroke range}}{65,535} \right)$$

Sample Calculations

Clockwise Shaft Rotation (positive direction):

B₇-B₆ = 0x89C6 (43462 Dec.), full stroke = 1 Turn

$$\left(\frac{35270 - 32767}{.1 \text{ sec}} \right) \times \left(\frac{1 \text{ Turn}}{65,535} \right) = .38 \text{ turns/ sec.}$$

Counter-Clockwise Shaft Rotation (negative direction):

B₇-B₆ = 0x61A8 (25000 Dec.), full stroke = 1 Turn

$$\left(\frac{25000 - 32767}{.1 \text{ sec}} \right) \times \left(\frac{1 \text{ Turn}}{65,535} \right) = -1.2 \text{ turns/ sec.}$$

Setting the Address (Node ID) and Baud Rate

Address Setting (Node ID)

The Address Setting (Node ID) is set via 6 switches located on the 8-pole DIP switch found on the DeviceNET controller board located inside the transducer.

The DIP switch settings are binary starting with switch number 1 (= 2⁰) and ending with switch number 6 (= 2⁵).

Baud Rate

The transmission baud rate may be either factory preset at the time of order or set manually at the time of installation.

The baud rate can be set using switches 7 & 8 on the 8-pole DIP switch found on the DeviceNET controller board located inside the transducer.

CANBus Controller Board

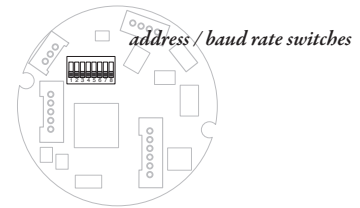

DIP-1 (2 ⁰)	DIP-2 (2 ¹)	DIP-3 (2 ²)	DIP-4 (2 ³)	DIP-5 (2 ⁴)	DIP-6 (2 ⁵)	address (decimal)
0	0	0	0	0	0	0
1	0	0	0	0	0	1
0	1	0	0	0	0	2
...
1	1	1	1	1	1	63

DIP-7	DIP-8	baud rate
0	0	125k
1	0	250k
0	1	500k
1	1	125k

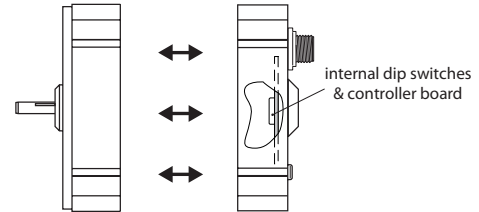

to gain access to the controller board, remove four Allen-Head Screws and separate case halves

Ordering Information:

Model Number:



Sample Model Number:

RT9CN - 30 - AL - 25 - J - 500 - 32 - SC5

- R** range: 30 turns
- A** enclosure: powder-painted aluminum
- B** shaft: .25-in diameter
- C** interface: CANbus SAE J1939
- D** baud rate: 500 k bits/sec.
- E** node ID: 32
- F** electrical connection: 5-meter cordset with straight plug

Full Stroke Range:

R order code:	R25	R50	1	2	3	5	10	20	30	50
clockwise shaft rotations, min:	0.25	0.50	1	2	3	5	10	20	30	50
accuracy (% of f.s.):	0.3%	0.3%	0.3%	0.3%	0.3%	0.2%	0.15%	0.15%	0.15%	0.15%
potentiometer cycle life*:	2.5 x 10 ⁶	2.5 x 10 ⁶	2.5 x 10 ⁶	2.5 x 10 ⁶	2.5 x 10 ⁶	5 x 10 ⁵	2.5 x 10 ⁵	2.5 x 10 ⁵	2.5 x 10 ⁵	2.5 x 10 ⁵

*-number of times the sensor shaft can be cycled back and forth from beginning to end and back to the beginning before any measurable signal degradation may occur.

Enclosure Material:

A order code:	AL	SS
	powder-painted aluminum	303 stainless steel

Shaft Diameter:

B order code:	25	6	25F	6F
	0.25-in. diameter	6 mm diameter	0.25-in. dia. w/flats	6 mm dia. w/flats
	.2497 in. (+.0000 -.0003)	5.995 mm (+.000 -.025)	0.33 in. ±0.025 in.	8.4 mm ±0.64 mm

Ordering Information:

Baud Rate:

① order code:	125	250	500
	125 kbaud	250 kbaud	500 kbaud

Node ID:

② order code:	0	1	2	...	62	63
	select address (0 - 63 Decimal)					

Electrical Connection:

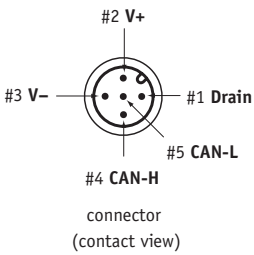
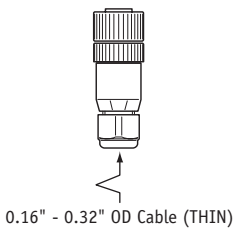
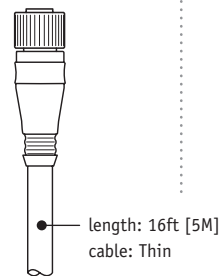
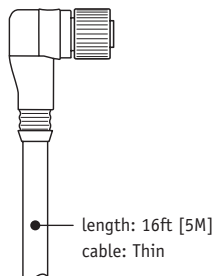
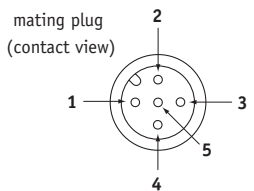
③ order code:	blank	MC5	SC5	NC5																		
	5-pin micro-connector <i>(no mating plug supplied)</i>	5-pin micro-connector w/ mating plug	5-pin micro-connector and 5 meter length cordset w/straight mating plug	5-pin micro-connector and 5 meter length cordset w/90° mating plug																		
	 <p>connector (contact view)</p>	 <p>0.16" - 0.32" OD Cable (THIN)</p>	 <p>length: 16ft [5M] cable: Thin</p>	 <p>length: 16ft [5M] cable: Thin</p>																		
		 <p>mating plug (contact view)</p>																				
			<table border="1"> <thead> <tr> <th>pin</th> <th>signal</th> <th>wire color</th> </tr> </thead> <tbody> <tr> <td>1</td> <td>drain</td> <td>brown</td> </tr> <tr> <td>2</td> <td>V+</td> <td>white</td> </tr> <tr> <td>3</td> <td>V-</td> <td>blue</td> </tr> <tr> <td>4</td> <td>Can-H</td> <td>black</td> </tr> <tr> <td>5</td> <td>Can-L</td> <td>grey</td> </tr> </tbody> </table>	pin	signal	wire color	1	drain	brown	2	V+	white	3	V-	blue	4	Can-H	black	5	Can-L	grey	
pin	signal	wire color																				
1	drain	brown																				
2	V+	white																				
3	V-	blue																				
4	Can-H	black																				
5	Can-L	grey																				

version: 5.1 last updated: December 7, 2010