



HF- Regulator 136 PL- L EII 220- 240V 50/60Hz

Product family description
Flat, lightweight high- frequency electronic
regulating ballast, using 1- 10V protocol for
PL- L fluorescent lamps

Features and Benefits

- Lamp power can be regulated from 1% to 100%
- Flat ballast design, 21 mm high
- Analog control input according to the 1- 10V industry standard
- Increased lamp wire flexibility thanks to the Parasitic Capacitance Compensation (longer lamp wiring possible up to 2 m)
- Protected against excessive mains voltages, incorrect connections and incorrect lamp use
- Striation- free operation, no stroboscopic effects
- Automatic stop circuit is activated within 5 s in case of lamp failure (safety stop)
- Ballast resets automatically after lamp replacement
- Equipped with WAGO 251 connectors suitable for automatic wiring machines
- Up to 60% reduction in energy consumption by using automatic lighting control systems
- Quick programmed start: 0.5 s, flicker- free warm start by preheating the lamp electrodes enables the lamps to be switched on and off without reducing useful life. Ideal for areas with a high switching frequency
- Smart power ensures constant light, independent of mains voltage fluctuations
- EII- dim technology: a dedicated IC for independent control of each electrode:
- lamp life is unaffected by dimming level
- stable lamp burning at every dimming level
- maximum energy savings in dimmed operation

Applications

- 1- 10V installations with daylight linking and/or movement detection (for energy savings)
- 1- 10V installations with remote control systems (combining energy savings with comfort)
- Installations with emergency back- up, according to IEC 60598- 2- 22

Product data	
Order code	911827 30
Full product code	871150091182730
Full product name	HF- Regulator 136 PL- L EII 220- 240V 50/60Hz
Order product name	HF- R 136 PL- L EII 220- 240V 50/60Hz

Product data	
Packing type	Unpacked
Pieces per pack	1
Packing configuration	12
Packs per outerbox	12
Bar code on pack - EAN1	8711500911827
Bar code on intermediate packing - EAN2	
Bar code on outerbox - EAN3	8711500911834
Logistic code(s) - 12NC	9137 006 19966
ILCOS code	
Net weight per piece	0.260 KG
Successor order code	
Interface	1- 10V
Rated Number of Lamps	1piece
Rated Ballast- Lamp Power	36
Rated Lamptype	PL- L
Application code	EII
Line Voltage	220- 240V
Line Frequency	50/60Hz
Energy Efficiency Index	A1



HF- R

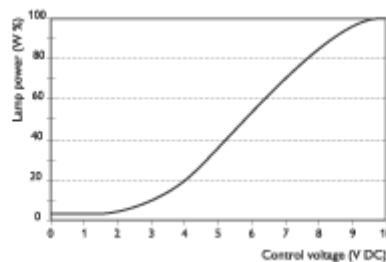

Relation between lamp power and 1- 10V regulation (with 1% dimming)

HF- R

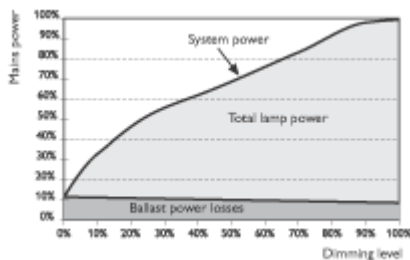

Input power vs dimlevel HR- REGULATOR II (1- 10V)

HF- R

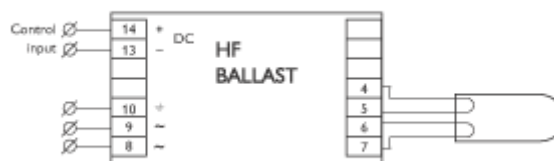

HF- R 1 PL- L/TL5/PL- L

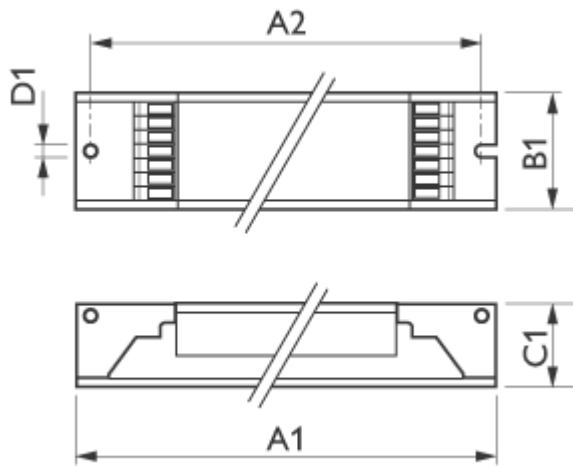

HF-R

	A1	A2	B1	C1	D1
Full product name	Nom	Nom	Nom	Nom	Nom
HF-Regulator 136 PL-L EII 220-2 40V 50/60 Hz	360	350	30	22	4.2

