

## UNIVERSAL TILT SENSOR SIGNAL CONDITIONER

### OVERVIEW

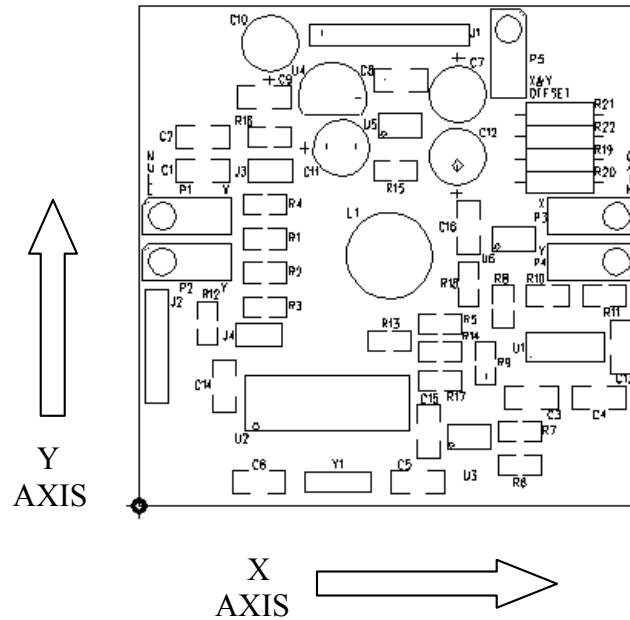
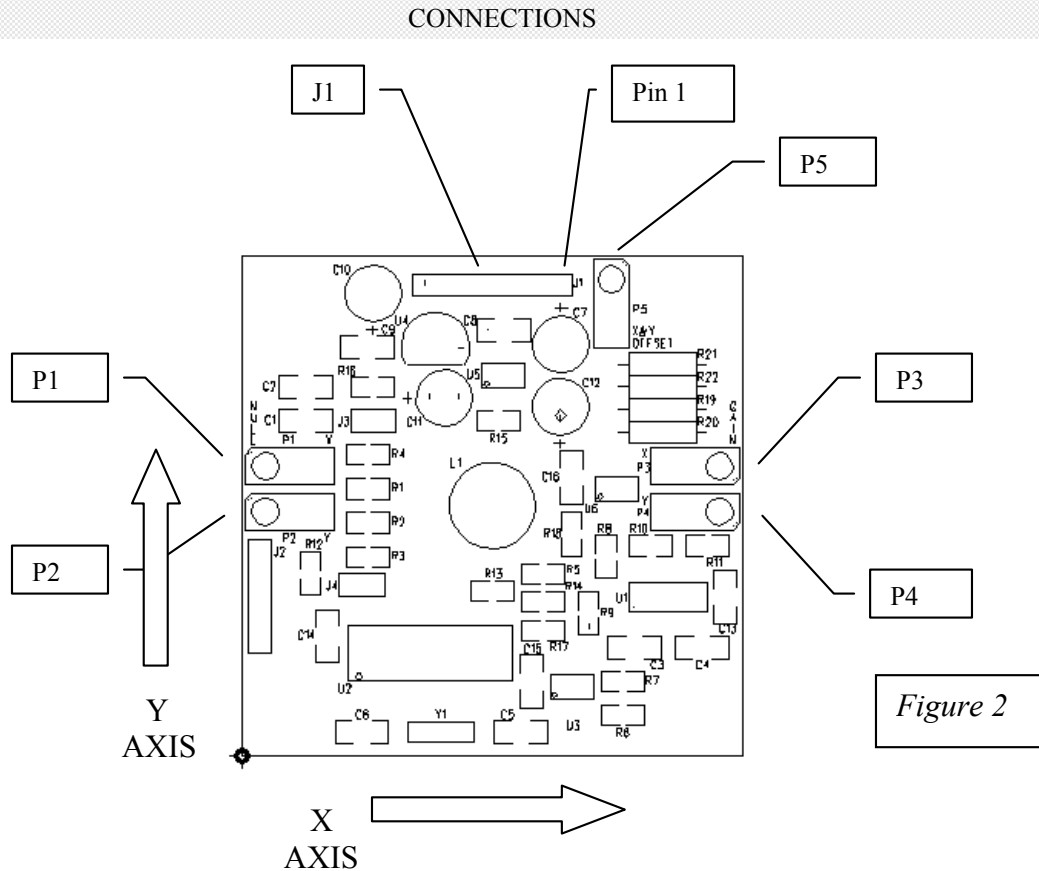

Figure 1

The Universal tilt sensor signal conditioner electronics (Figure 1) is designed to operate with a variety of tilt sensors to provide a calibrated angular output. The signal conditioner will accommodate single or dual axis tilt sensors. The sensor can be mounted directly to the board or off the board connected via wires. The electronics has a computer chip that does all the excitation to the sensor and conversion of the signal from the sensor. The only connections to the signal conditioner are thru the J1 connector. A single supply voltage is all that is required to power the signal conditioner. There is an on board inverter to provide negative voltage outputs. The signal conditioners output consists of analog voltages and digital (pulse width modulation) signals. The analog output is provided by a 12-bit digital to analog converter. The digital output has 10-bits of resolution. The digital range is always enabled along with the selected analog range. There are on board adjustments for gain and offset within the range selected. Below is a table of available analog and digital output ranges for a user specified sensors angular range.

<u>Analog Range</u>	<u>Angular Range</u>	<u>Supply Voltage</u>
0 to +5 V	+/- specified angle	7 V min.
0 to +10 V	+/- specified angle	12 V min.
-2.5 to +2.5 V	+/- specified angle	7 V min.
-5 to +5 V	+/- specified angle	7 V min.
-10 to +10 V	+/- specified angle	12 V min.
<u>Digital Range</u>	<u>Angular Range</u>	<u>Supply Voltage</u>
10 to 90 % (pwm)	+/- specified angle	7 V min.



Power and Signal connections (see figure 2):

- J1 - 1 +7 to +16 Volts DC (see selected analog range for minimum required voltage).
- J1 - 2 Common.
- J1 - 3 Negative inverter output.
- J1 - 4 X-axis analog output (for selected analog range).
- J1 - 5 Y-axis analog output (for selected analog range).
- J1 - 6 X-axis pulse width modulated output.
- J1 - 7 Y-axis pulse width modulated output.

#### MOUNTING AND ADJUSTMENTS

The signal conditioner board has 4 mounting holes. The spacing is 1.8 inches in each direction. If the sensor is mounted directly to the board, it is necessary to mount the board horizontally and close to gravity. If the sensor is mounted remotely, the board may be mounted in any manner. Once the board and sensor installation is complete, it may be necessary to make minor adjustments to the output. Below is a description of the adjustments available.

Sensor trim adjustments (see Figure 2):

- P1 – X null
- P2 – Y null
- P3 – X gain
- P4 – Y gain
- P5 – Analog dac offset

P1 and P2 are offset adjustments for the X and Y analog and digital outputs when the board is in the null or non-tilted position.

P3 and P4 are gain adjustments for the X and Y analog and digital outputs when the board is tilted to the specified angle.

P5 is the analog dac offset for the X and Y outputs. This adjustment is made in the null position and used to set the analog midpoint when the pulse width modulated output is at 50 percent duty cycle.

Note: The X-axis is used for single axis sensors.

#### CALIBRATION

Note: For single axis sensors, P2 and P4 do not need to be adjusted.

Adjust P1 and P2 for 50% duty cycle on the digital X and Y outputs with the sensor in the null or non-tilted position.

Adjust P5 to set the analog X and Y voltage outputs close to the midpoint of the selected voltage range.

P1 and P2 may need minor readjustments to set the analog X and Y voltage outputs to the midpoint of the selected voltage range. This step may be skipped if the digital output is being used.

Adjust P3 and P4 for the selected X and Y analog voltage range when the sensor is tilted to the selected angular range. If the digital output is being used, adjust P3 and P4 for the X and Y outputs to 10 and 90 percent of the selected angular range.

