



ACA2404

750/870 MHz CATV

High Output Power Doubler Line Amplifier

ADVANCED PRODUCT INFORMATION - Rev 0.0

FEATURES

- 21.5 dB Gain
- Characterized at +58 dBmV Output
- Very Low Distortion
- Excellent 75 Ω Input and Output Match
- Stable with High VSWR Load Conditions
- Monolithic Design for Consistent Performance Part-to-Part
- Surface Mount Package Compatible with Automatic Assembly
- Low Cost Alternative to Hybrids
- Meets Cenelec Standards

APPLICATIONS

- CATV Line Amplifiers, System Amplifiers, Distribution Nodes



**S7 Package
16 Pin Wide Body SOIC
with Heat Slug**

PRODUCT DESCRIPTION

The ACA2404 is a highly linear, high output power, monolithic GaAs RF amplifier that has been developed to replace standard CATV hybrid amplifiers, in new designs. Offered in a convenient surface mount package, the MMIC consists of two pairs of parallel amplifiers that are optimized for

exceptionally low distortion and noise figure. A hybrid equivalent that provides flat gain response and excellent input and output return loss over the 40 to 870 MHz CATV downstream band is formed when one ACA2404 is cascaded between two appropriate transmission line baluns.

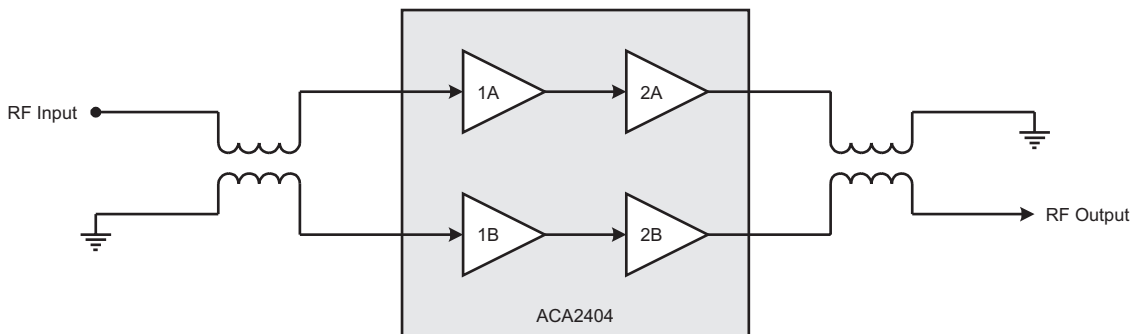

Figure 1: Hybrid Application Diagram

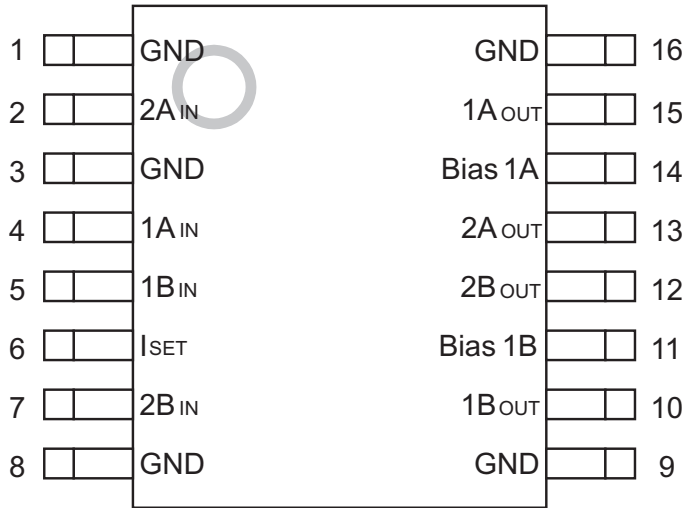

Figure 2: Pin Out

Table 1: Pin Description

PIN	NAME	DESCRIPTION	PIN	NAME	DESCRIPTION
1	GND	Ground	9	GND	Ground
2	2A _{IN}	Amplifier 2A Input	10	1B _{OUT}	Amplifier 1B Output
3	GND	Ground	11	Bias 1B	Bias for 1B Amplifier
4	1A _{IN}	Amplifier 1A Input	12	2B _{OUT}	Amplifier 2B Output and Supply
5	1B _{IN}	Amplifier 1B Input	13	2A _{OUT}	Amplifier 2A Output and Supply
6	I _{SET}	Current Adjust	14	Bias 1A	Bias for 1A Amplifier
7	2B _{IN}	Amplifier 2B Input	15	1A _{OUT}	Amplifier 1A Output
8	GND	Ground	16	GND	Ground

ELECTRICAL CHARACTERISTICS**Table 2: Absolute Mimimum and Maximum Ratings**

PARAMETER	MIN	MAX	UNIT
Supply (pins 12, 13)	0	+28	VDC
Current Adjust (pin 6)	0	+4	VDC
RF Power at Inputs (pins 4, 5)	-	+75	dBmV
Storage Temperature	-65	+150	°C
Soldering Temperature	-	+260	°C
Soldering Time	-	5.0	Sec

Stresses in excess of the absolute ratings may cause permanent damage. Functional operation is not implied under these conditions. Exposure to absolute ratings for extended periods of time may adversely affect reliability.

Notes:

1. Pins 2, 4, 5 and 7 should be AC-coupled. No external DC bias should be applied.
2. Pins 11 and 14 are bias feeds for input amplifiers 1A and 1B. No external DC bias should be applied.
3. Pins 10 and 15 receive DC bias directly from pins 11 and 14. No other external bias should be applied.

Table 3: Operating Ranges

PARAMETER	MIN	TYP	MAX	UNIT
Supply: V _{DD} (pins 12, 13)	-	+24	-	VDC
Current Adjust (pin 6)	-	+3	-	VDC
RF Frequency	40	-	870	MHz
Case Temperature	-40	-	+110	°C

The device may be operated safely over these conditions; however, parametric performance is guaranteed only over the conditions defined in the electrical specifications.

Table 4: AC and DC Electrical Specifications**(T_A = +25 °C, V_{DD} = +24 VDC)**

PARAMETER	MIN	TYP	MAX	UNIT	COMMENTS
Gain at 870 MHz ⁽¹⁾	20.8	21.5	22.1	dB	
Cable Equivalent Slope ⁽¹⁾	-	0	-	dB	
Gain Flatness ⁽¹⁾ to 870 MHz	-	± 0.2	-	dB	
Noise Figure ⁽¹⁾	-	4.0	5.0	dB	
CTB ⁽¹⁾ 77 Channels ⁽²⁾ 110 Channels ⁽³⁾	- - -	-75 -67	-70 -	dBc	
CSO ⁽¹⁾ 77 Channels ⁽²⁾ 110 Channels ⁽³⁾	- - -	-69 -64	-67 -	dBc	
XMOD ⁽¹⁾ 77 Channels ⁽²⁾ 110 Channels ⁽³⁾	- - -	-62 -60	-60 -	dBc	
Return Loss (Input/Output) ⁽¹⁾	18	22	-	dB	75 Ω system
Supply Current	485	500	515	mA	
Thermal Resistance	-	2.7	3.3	°C/W	

Notes:*(1) Measured with baluns on the input and output of the device.**(2) Parts measured with 77 channels, +58 dBmV power, 13.5 dB tilt at 870 MHz.**(3) Parts measured with 110 channels, +54 dBmV power, 13.5 dB tilt at 870 MHz.**4. All specifications as measured on Evaluation Board (see Figures 13 & 14).*

PERFORMANCE DATA

Figure 3: Noise Figure vs. Frequency
($T_A = +25\text{ }^\circ\text{C}$, $V_{DD} = +24\text{ V}$)

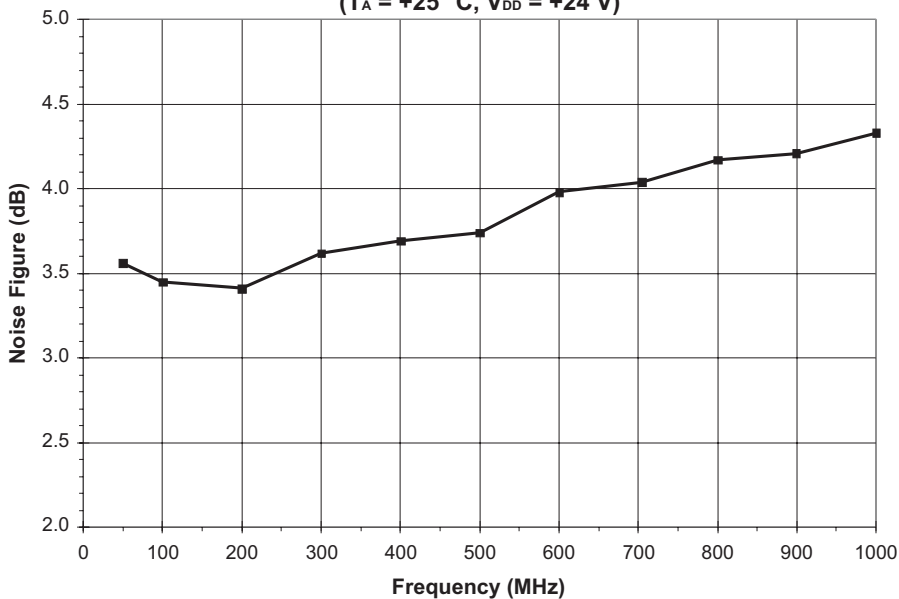

Figure 4: Gain (S21) vs. Frequency
($T_A = +25\text{ }^\circ\text{C}$, $V_{DD} = +24\text{ V}$, $75\text{ }\Omega$ system)

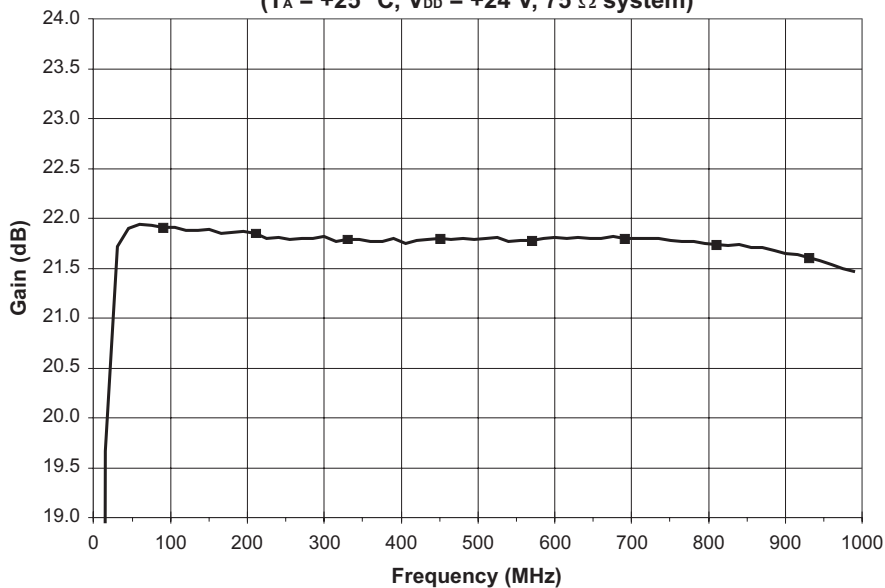

Figure 5: Input and Output Return Loss (S11 and S22) vs. Frequency
($T_A = +25\text{ }^\circ\text{C}$, $V_{DD} = +24\text{ V}$, $75\ \Omega$ system)

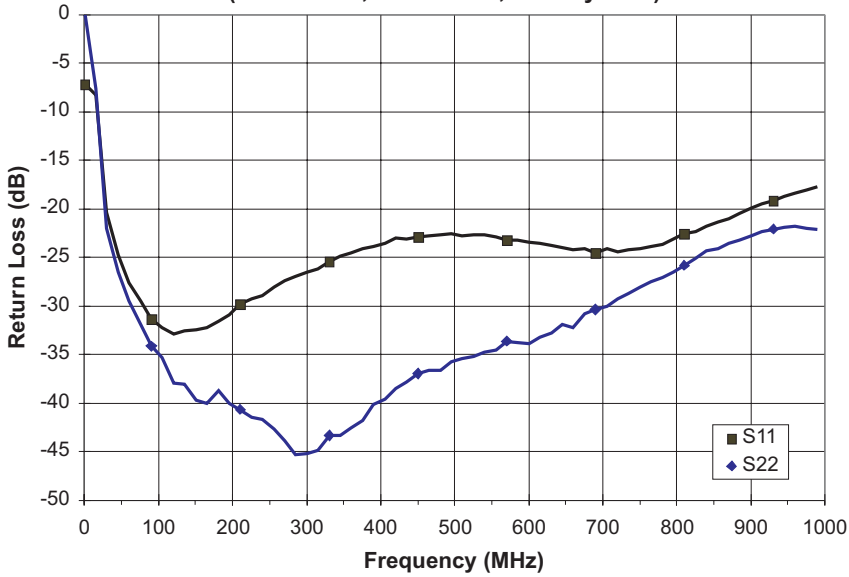

Figure 6: Isolation (S12) vs. Frequency
($T_A = +25\text{ }^\circ\text{C}$, $V_{DD} = +24\text{ V}$, $75\ \Omega$ system)

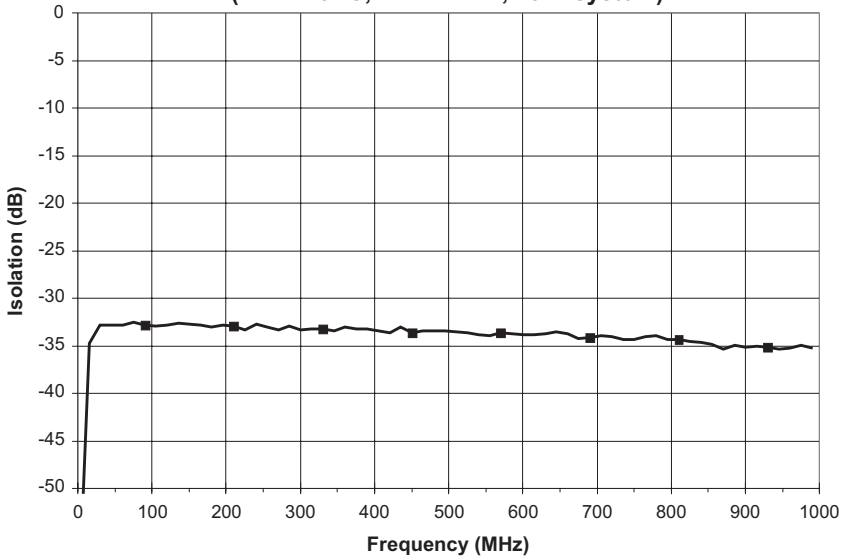

Figure 7: CTB vs. Frequency
(110 channels, +54 dBmV power, 13.5 dB tilt at 870 MHz)

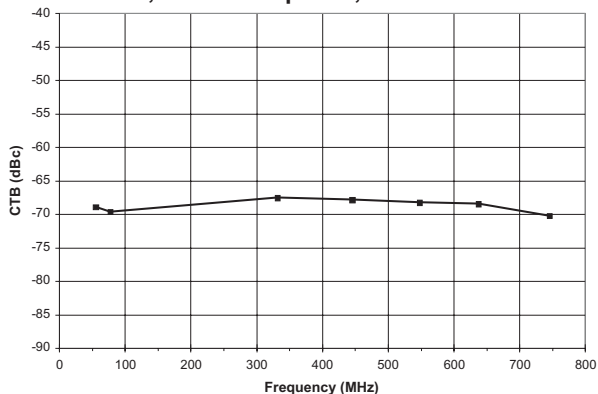

Figure 8: CSO vs. Frequency
(110 channels, +54 dBmV power, 13.5 dB tilt at 870 MHz)

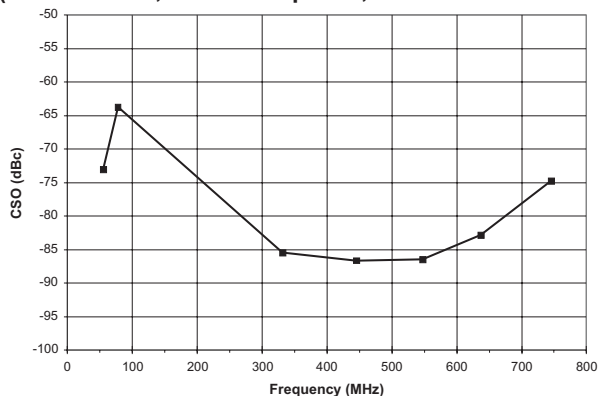

Figure 9: XMOD vs. Frequency
(110 channels, +54 dBmV power, 13.5 dB tilt at 870 MHz)

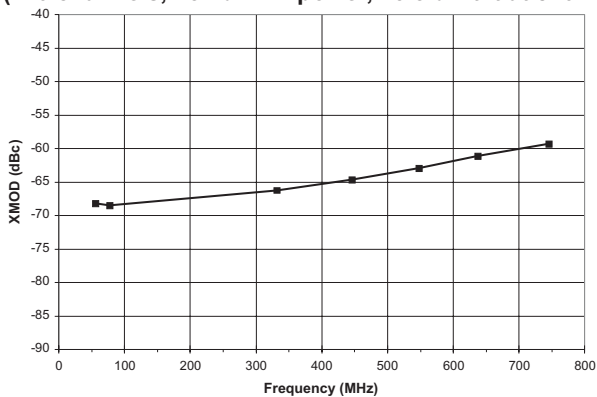

Figure 10: CTB vs. Frequency
(77 channels, +58 dBmV power, 13.5 dB tilt at 870 MHz)

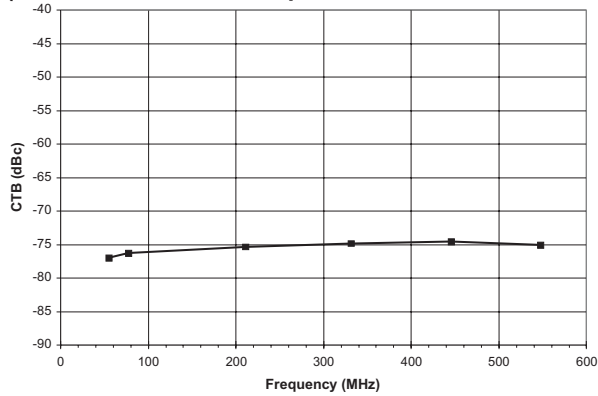

Figure 11: CSO vs. Frequency
(77 channels, +58 dBmV power, 13.5 dB tilt at 870 MHz)

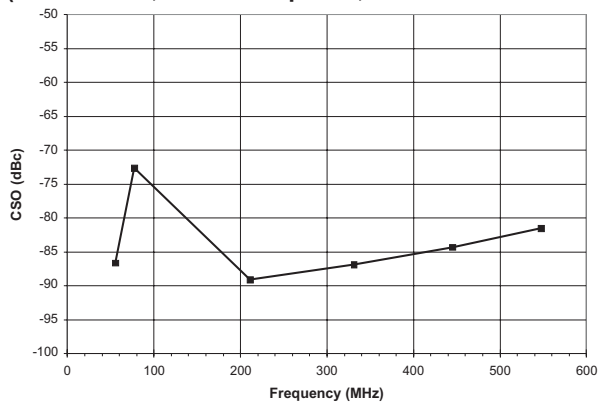
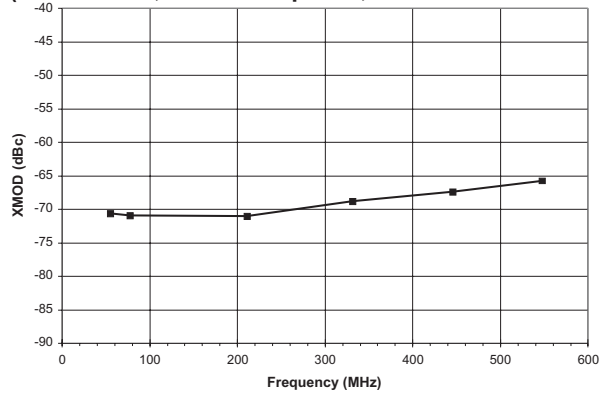

Figure 12: XMOD vs. Frequency
(77 channels, +58 dBmV power, 13.5 dB tilt at 870 MHz)



APPLICATION INFORMATION

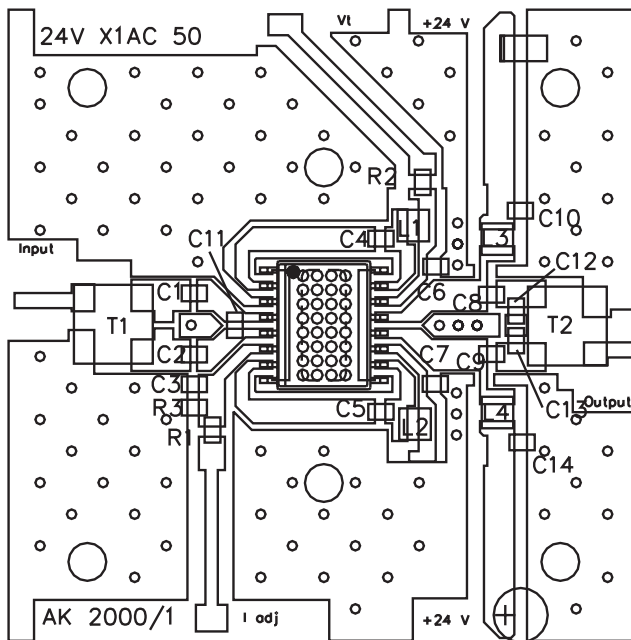

Figure 13: Evaluation Board Layout

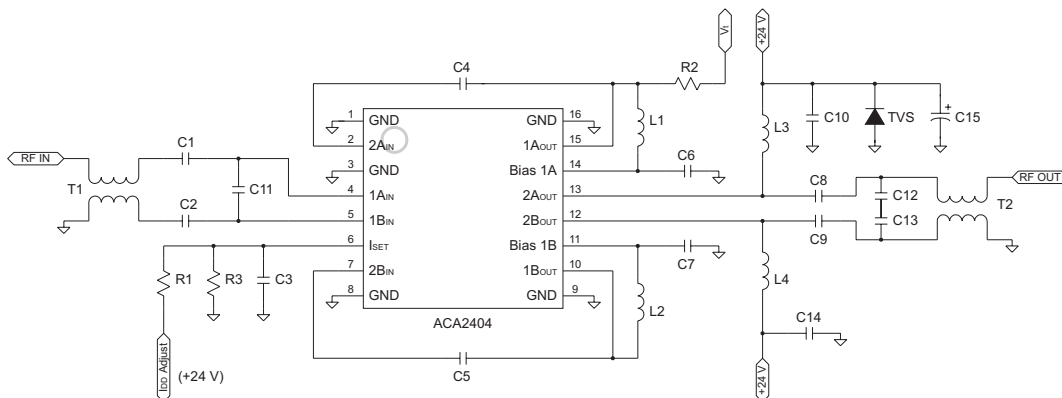

Figure 14: Evaluation Board Schematic

Table 5: Evaluation Board Parts List

REF	DESCRIPTION	QTY	VENDOR	VENDOR P/N
C1, C2, C3, C6, C7, C10, C14	0.01 μ F CHIP CAP	7	MURATA	GRM39X7R103K50V
C4, C5, C8, C9	470 pF CHIP CAP	4	MURATA	GRM39X7R471K50V
C11	0.5 pF CHIP CAP	1	MURATA	GRM36COG0R5C50
C15	47 μ F ELECT. CAP	1	DIGI-KEY CORP	P5275-ND
C12, C13, R1, R2, R3	NOT USED			
TVS	TVS 24 VOLT 600 WATT	1	DIGI-KEY CORP	SMBJ24ACCCT-ND
L1, L2, L3, L4 ⁽⁴⁾	680 nH INDUCTOR	4	COILCRAFT	1008CS-681XKBC
R1	75 K Ω Resistor	1	DIGI-KEY CORP	P75KGCT-ND
CONNECTOR ⁽¹⁾	75 Ω N MALE PANEL MOUNT	2	PASTERNAK ENTERPRISES	PE4504
T1, T2 ⁽²⁾ (BALUN)	Ferrite Core	2	FAIR-RITE	2843002702
	Wire		MWS WIRE IND.	T-2361429-20
	Printed Circuit Board ⁽³⁾	1	STANDARD PRINTED CIRC. INC	24VX1AC50
INDIUM	300 X 160 MILS	1	INDIUM CORP OF AMERICA	14996Y

Notes:

(1) N connector center pin should be approximately 80 mils in length.

(2) T1, T2 balun: 6.5 turns thru, as shown in Figure 15.

(3) Due to the power dissipation of this device, the printed circuit board should be mounted / attached to a heat sink.

(4) 400 mA minimum current rating.

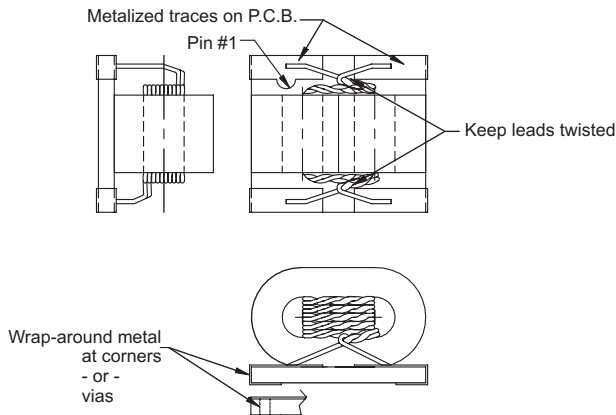
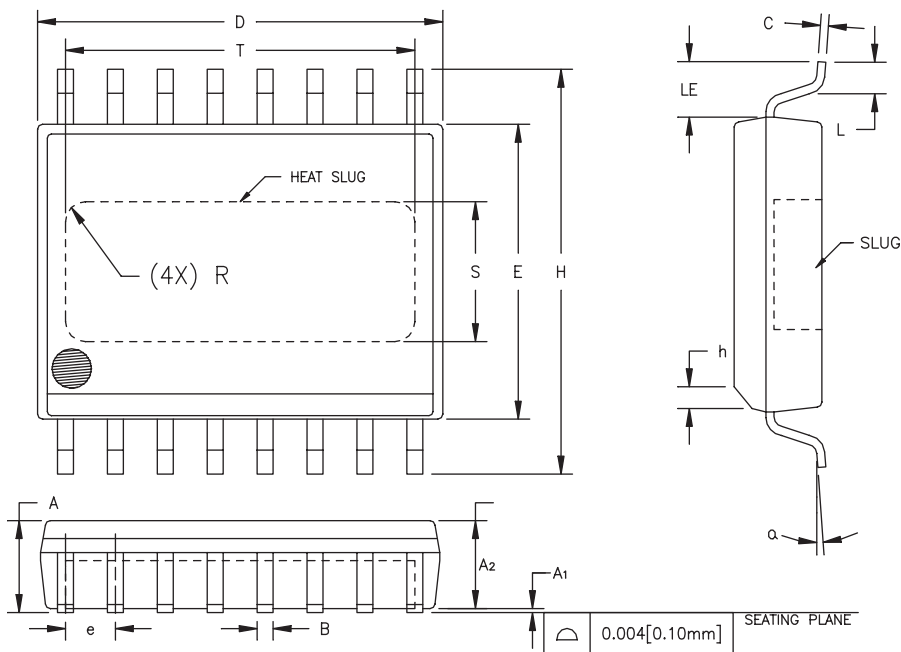

Figure 15: Balun Drawing

PACKAGE OUTLINE



S _M B _{OL}	INCHES		MILLIMETERS		NOTE
	MIN.	MAX.	MIN.	MAX.	
A	0.087	0.098	2.21	2.49	
A ₁	0.000	0.004	0.00	0.10	6
A ₂	0.087	0.094	2.21	2.39	
B	0.013	0.019	0.33	0.48	
C	0.007	0.009	0.18	0.23	
D	0.398	0.412	10.11	10.46	2
E	0.290	0.300	7.37	7.62	3
e	0.050	BSC	1.27	BSC	4
H	0.394	0.418	10.01	10.62	
h	0.010	0.028	0.25	0.71	
L	0.024	0.040	0.61	1.02	
LE	0.052	—	1.32	—	
α	0°	8°	0°	8°	
S	0.120	0.140	3.05	3.56	5
T	0.330	0.350	8.38	8.89	5
R	REF.	0.015	REF.	0.38	5

NOTES:

1. CONTROLLING DIMENSION: INCHES
2. DIMENSION "D" DOES NOT INCLUDE MOLD FLASH, PROTRUSIONS OR GATE BURRS. MOLD FLASH, PROTRUSIONS AND GATE BURRS SHALL NOT EXCEED 0.006 [0.15mm] PER SIDE.
3. DIMENSION "E" DOES NOT INCLUDE INTER-LEAD FLASH OR PROTRUSIONS. INTER-LEAD FLASH AND PROTRUSIONS SHALL NOT EXCEED 0.010 [0.25mm] PER SIDE.
4. MAXIMUM LEAD TWIST/SKEW TO BE ±0.005 [0.13mm].
5. DIMENSIONS "S", "T" AND "R" INDICATE EXPOSED SLUG AREA.
6. STANDOFF HEIGHT (A₁) MEASURED FROM BOTTOM OF SLUG.

Figure 16: S7 Package Outline - 16 Pin Wide Body SOIC with Heat Slug

ORDERING INFORMATION

ORDER NUMBER	TEMPERATURE RANGE	PACKAGE DESCRIPTION	COMPONENT PACKAGING
ACA2404S7P2	-40 to 110 °C	16 Pin Wide Body SOIC with Heat Slug	1,500 piece tape and reel
ACA2404S7P0	-40 to 110 °C	16 Pin Wide Body SOIC with Heat Slug	Plastic tubes (25 pieces per tube)



ANADIGICS, Inc.

141 Mount Bethel Road
Warren, New Jersey 07059, U.S.A.

Tel: +1 (908) 668-5000

Fax: +1 (908) 668-5132

URL: <http://www.anadigics.com>

E-mail: Mktg@anadigics.com

IMPORTANT NOTICE

ANADIGICS, Inc. reserves the right to make changes to its products or to discontinue any product at any time without notice. The product specifications contained in Advanced Product Information sheets and Preliminary Data Sheets are subject to change prior to a product's formal introduction. Information in Data Sheets have been carefully checked and are assumed to be reliable; however, ANADIGICS assumes no responsibilities for inaccuracies. ANADIGICS strongly urges customers to verify that the information they are using is current before placing orders.

WARNING

ANADIGICS products are not intended for use in life support appliances, devices or systems. Use of an ANADIGICS product in any such application without written consent is prohibited.

SUNSTAR 商斯达实业集团是集研发、生产、工程、销售、代理经销、技术咨询、信息服务等为一体的高科技企业，是专业高科技电子产品生产厂家，是具有 10 多年历史的专业电子元器件供应商，是中国最早和最大的仓储式连锁规模经营大型综合电子零部件代理分销商之一，是一家专业代理和分销世界各大品牌 IC 芯片和电子元器件的连锁经营综合性国际公司，专业经营进口、国产名厂名牌电子元件，型号、种类齐全。在香港、北京、深圳、上海、西安、成都等全国主要电子市场设有直属分公司和产品展示展销窗口门市部专卖店及代理分销商，已在全国范围内建成强大统一的供货和代理分销网络。我们专业代理经销、开发生产电子元器件、集成电路、传感器、微波光电元器件、工控机/DOC/DOM 电子盘、专用电路、单片机开发、MCU/DSP/ARM/FPGA 软件硬件、二极管、三极管、模块等，是您可靠的一站式现货配套供应商、方案提供商、部件功能模块开发配套商。商斯达实业公司拥有庞大的资料库，有数位毕业于著名高校——有中国电子工业摇篮之称的西安电子科技大学（西军电）并长期从事国防尖端科技研究的高级工程师为您精挑细选、量身订做各种高科技电子元器件，并解决各种技术问题。

微波光电部专业代理经销高频、微波、光纤、光电元器件、组件、部件、模块、整机；电磁兼容元器件、材料、设备；微波 CAD、EDA 软件、开发测试仿真工具；微波、光纤仪器仪表。欢迎国外高科技微波、光纤厂商将优秀产品介绍到中国、共同开拓市场。长期大量现货专业批发高频、微波、卫星、光纤、电视、CATV 器件：晶振、VCO、连接器、PIN 开关、变容二极管、开关二极管、低噪晶体管、功率电阻及电容、放大器、功率管、MMIC、混频器、耦合器、功分器、振荡器、合成器、衰减器、滤波器、隔离器、环行器、移相器、调制解调器；光电子器件和组件：红外发射管、红外接收管、光电开关、光敏管、发光二极管和发光二极管组件、半导体激光二极管和激光器组件、光电探测器和光接收组件、光发射接收模块、光纤激光器和光放大器、光调制器、光开关、DWDM 用光发射和接收器件、用户接入系统光收发器件与模块、光纤连接器、光纤跳线/尾纤、光衰减器、光纤适配器、光隔离器、光耦合器、光环行器、光复用器/转换器；无线收发芯片和模组、蓝牙芯片和模组。

更多产品请看本公司产品专用销售网站：

商斯达中国传感器科技信息网：<http://www.sensor-ic.com/>

商斯达工控安防网：<http://www.pc-ps.net/>

商斯达电子元器件网：<http://www.sunstare.com/>

商斯达微波光电产品网：[HTTP://www.rfoe.net/](http://www.rfoe.net/)

商斯达消费电子产品网：<http://www.icasic.com/>

商斯达实业科技产品网：<http://www.sunstars.cn/> 微波元器件销售热线：

地址：深圳市福田区福华路福庆街鸿图大厦 1602 室

电话：0755-82884100 83397033 83396822 83398585

传真：0755-83376182 (0) 13823648918 MSN: SUNS8888@hotmail.com

邮编：518033 E-mail:szss20@163.com QQ: 195847376

深圳赛格展销部：深圳华强北路赛格电子市场 2583 号 电话：0755-83665529 25059422

技术支持：0755-83394033 13501568376

欢迎索取免费详细资料、设计指南和光盘；产品凡多，未能尽录，欢迎来电查询。

北京分公司：北京海淀区知春路 132 号中发电子大厦 3097 号

TEL: 010-81159046 82615020 13501189838 FAX: 010-62543996

上海分公司：上海市北京东路 668 号上海赛格电子市场 D125 号

TEL: 021-28311762 56703037 13701955389 FAX: 021-56703037

西安分公司：西安高新开发区 20 所(中国电子科技集团导航技术研究所)

西安劳动南路 88 号电子商城二楼 D23 号

TEL: 029-81022619 13072977981 FAX:029-88789382