



FEATURES

- High Linearity: +15 dBm IIP3 (+8 V supply)
- Low Distortion
- Low Noise Figure: 2.0 dB
- 15 dB Gain
- Single +4 V to +9 V Supply
- Wide Bandwidth: 50 MHz to 1 GHz
- SOIC-16 and SOT-89 Package Options



PRODUCT DESCRIPTION

The ADA10000 is a monolithic IC intended for use in applications requiring high linearity, such as Cellular Telephone Base Station Driver Amplifiers, CATV Fiber Receiver and Distribution Amplifiers, and CATV Drop

Amplifiers. Offered in both a modified 16 lead SOIC package and SOT-89 package, it is well suited for use in amplifiers where small size, reduced component count, and high reliability are important.

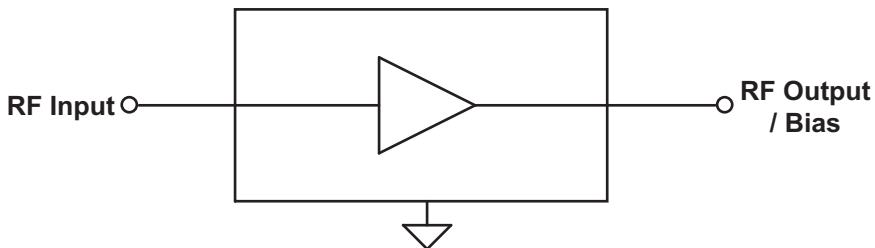

Figure 1: Block Diagram

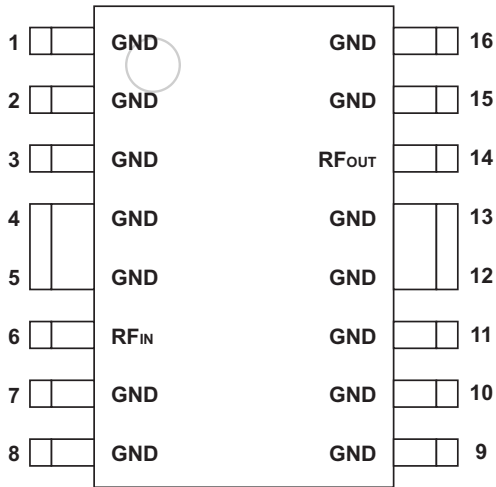

Figure 2: Pinout - S3 Package

Table 1: Pin Description - S3 Package

PIN	NAME	DESCRIPTION	PIN	NAME	DESCRIPTION
1	GND	Ground	16	GND	Ground
2	GND	Ground	15	GND	Ground
3	GND	Ground	14	RF _{OUT}	RF Output / Bias
4	GND	Ground	13	GND	Ground
5	GND	Ground	12	GND	Ground
6	RF _{IN}	RF Input	11	GND	Ground
7	GND	Ground	10	GND	Ground
8	GND	Ground	9	GND	Ground

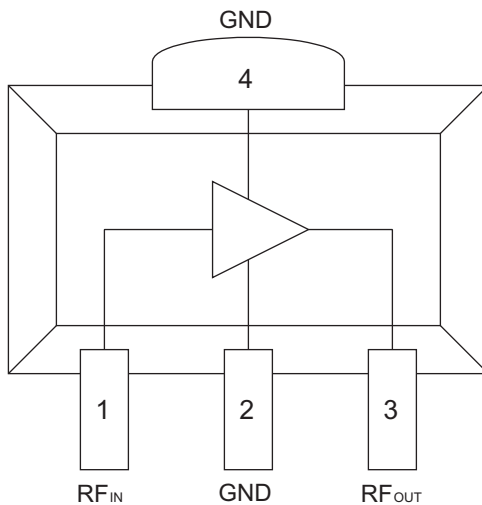

Figure 3: Pinout - S24 Package

Table 2: Pin Description - S24 Package

PIN	NAME	DESCRIPTION
1	RF _{IN}	RF Input
2	GND	Ground
3	RF _{OUT}	RF Output / Bias
4	GND	Ground

ELECTRICAL CHARACTERISTICS

Table 3: Absolute Minimum and Maximum Ratings

PARAMETER	MIN	MAX	UNIT
Supply (S3 package: pin 14) (S24 package: pin 3)	0	+12	VDC
RF Power at Input (S3 package: pin 6) (S24 package: pin 1)	-	+10	dBm
Storage Temperature	-65	+150	°C

Stresses in excess of the absolute ratings may cause permanent damage. Functional operation is not implied under these conditions. Exposure to absolute ratings for extended periods of time may adversely affect reliability.

Notes:

(1) RF input pin must be AC-coupled. No DC external bias should be applied.

Table 4: Operating Ranges

PARAMETER	MIN	TYP	MAX	UNIT
RF Input / Output Frequency	50	-	1000	MHz
Supply Voltage (V _{DD})	+4	+8	+9	VDC
Case Temperature	-40	-	+85 ⁽¹⁾	°C

The device may be operated safely over these conditions; however, parametric performance is guaranteed only over the conditions defined in the electrical specifications.

Notes:

(1) Median time to failure will degrade above this temperature.

Table 5: Electrical Specifications
(T_A = +25 °C, V_{DD} = +8 VDC, 75 Ω system, see Figures 4 and 5)

PARAMETER	MIN	TYP	MAX	UNIT	COMMENT
CSO ⁽¹⁾ / CSO ⁽²⁾	60 / 62	-	-	dBc	
CTB ⁽¹⁾ /CTB ⁽²⁾	65 / 74	-	-	dBc	
Gain	14	15	-	dB	
Noise Figure	-	2.0	3.5	dB	
2nd Order Input Intercept Point (IIP2) ⁽³⁾	+29	+34	-	dBm	
3rd Order Input Intercept Point (IIP3) ⁽³⁾	+13	+15	-	dBm	
Thermal Resistance	-	-	35 20	°C/W	S3 package S24 package
Current Consumption ⁽⁴⁾	50	-	150	mA	

Notes:

(1) 160 channels, +17 dBmV per channel (measured at output), 6 MHz channel spacing.

(2) 80 channels, +19 dBmV per channel (measured at output), 6 MHz channel spacing.

(3) Two tones, -10 dBm per tone at input.

(4) The device can be operated at V_{DD} = +6 VDC for lower power dissipation. Refer to Figures 7, 8, 13, and 16 for performance variation with supply voltage.

ADA10000

SUNSTAR微波光电 <http://www.rfoe.net/> TEL:0755-83396822 FAX:0755-83376182 E-MAIL:szss20@163.com

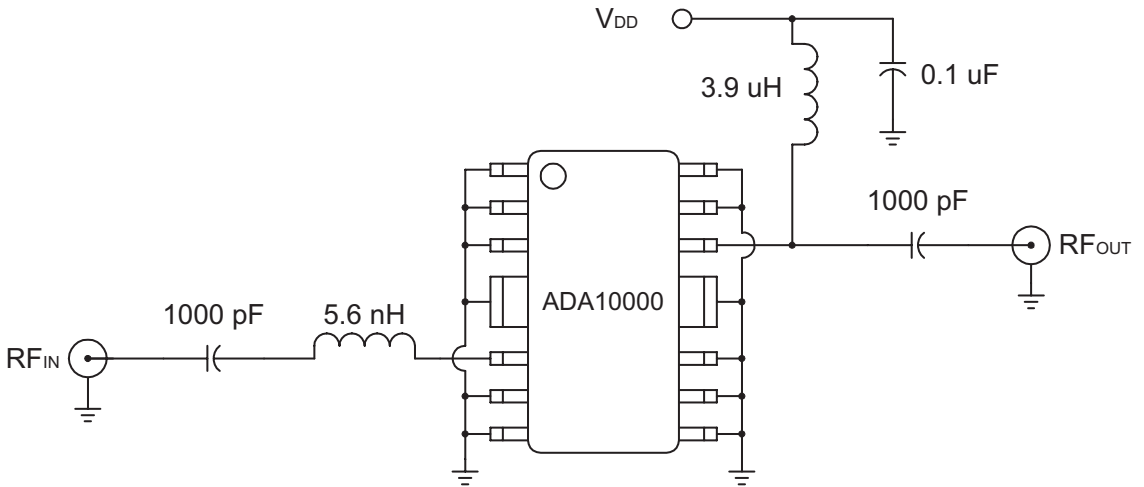

Figure 4: Test Circuit - S3 Packaged Device (75 Ω terminations)

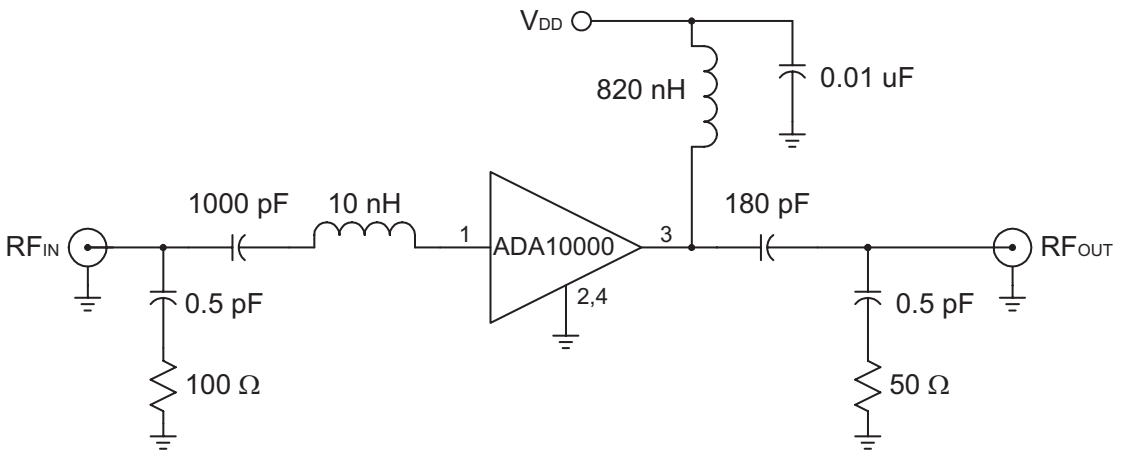

Figure 5: Test Circuit - S24 Packaged Device (75 Ω terminations)

PERFORMANCE DATA

As measured in test circuits shown in Figures 4 and 5.

Figure 6: Gain and Noise Figure vs. Frequency - S3 Packaged Device
($T_A = +25\text{ }^\circ\text{C}$, $V_{DD} = +8\text{ V}$, $75\ \Omega$ system)

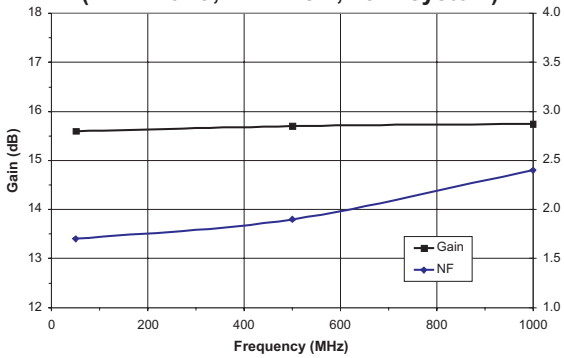

Figure 7: Gain and Noise Figure vs. Supply Voltage - S3 Packaged Device
($T_A = +25\text{ }^\circ\text{C}$, $f = 500\text{ MHz}$, $75\ \Omega$ system)

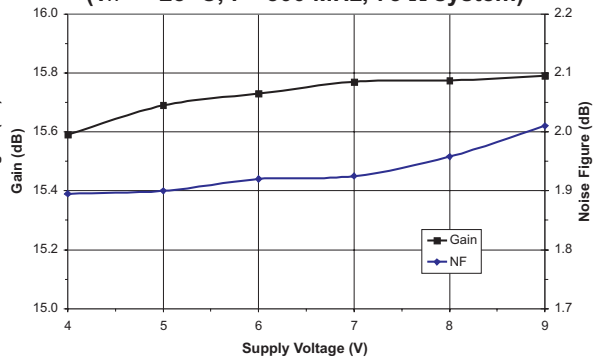

Figure 8: IIP2 and IIP3 vs. Supply Voltage - S3 Packaged Device
($T_A = +25\text{ }^\circ\text{C}$, $75\ \Omega$ system)

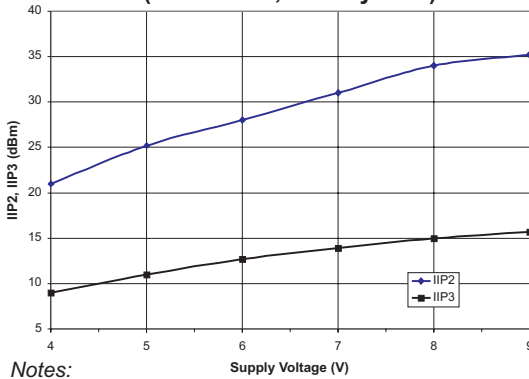
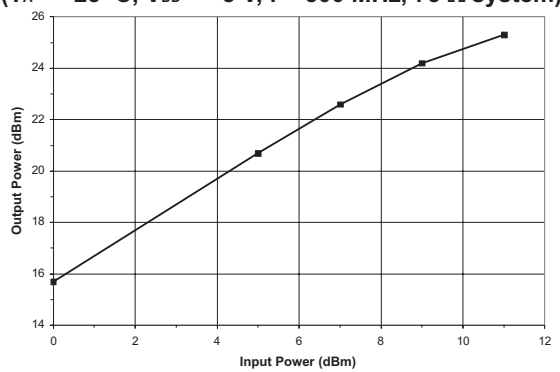

Figure 9: Output Power vs. Input Power S3 Packaged Device
($T_A = +25\text{ }^\circ\text{C}$, $V_{DD} = +8\text{ V}$, $f = 500\text{ MHz}$, $75\ \Omega$ system)



Notes:

1. IIP2 measured at 986.5 MHz; Input = two tones at 55.25 MHz and 931.25 MHz at -10 dBm.
2. IIP3 measured with two tones at the input: 986.5 MHz and 992.5 MHz at -10 dBm.

Figure 10: Unmatched Device Input Impedance S3 Packaged Device
($T_A = +25\text{ }^\circ\text{C}$, $V_{DD} = +8\text{ V}$, $75\ \Omega$ system)

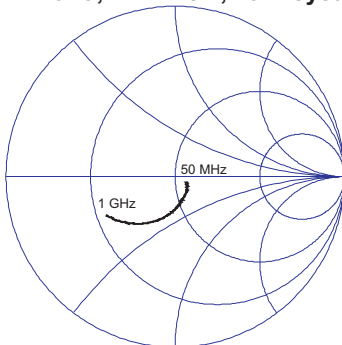
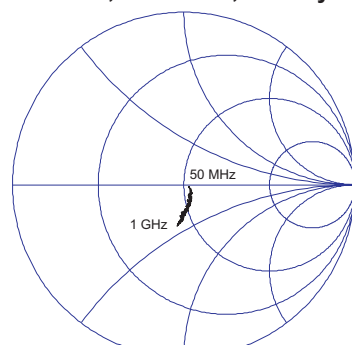

Figure 11: Unmatched Device Output Impedance S3 Packaged Device
($T_A = +25\text{ }^\circ\text{C}$, $V_{DD} = +8\text{ V}$, $75\ \Omega$ system)



Refer to the ANADIGICS web site for full 2-port s-parameter data.

Figure 12: Gain and Noise Figure vs. Frequency - S24 Packaged Device
($T_A = +25\text{ }^\circ\text{C}$, $V_{DD} = +8\text{ V}$, $75\ \Omega$ system)

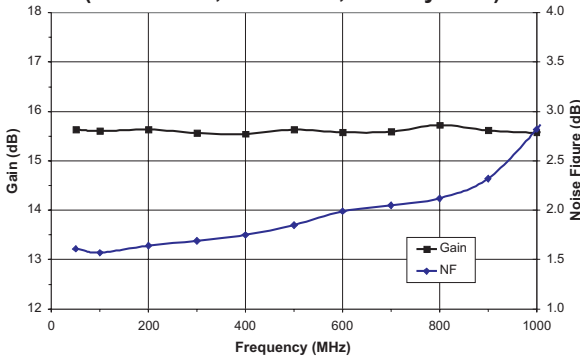

Figure 13: Gain and Noise Figure vs. Supply Voltage - S24 Packaged Device
($T_A = +25\text{ }^\circ\text{C}$, $f = 500\text{ MHz}$, $75\ \Omega$ system)

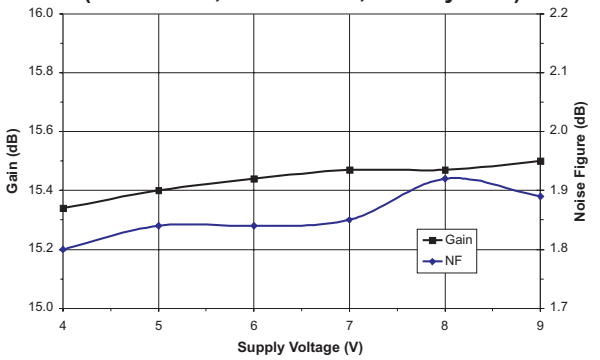

Figure 14: Input Return Loss vs. Frequency - S24 Packaged Device
($T_A = +25\text{ }^\circ\text{C}$, $V_{DD} = +8\text{ V}$, $75\ \Omega$ system)

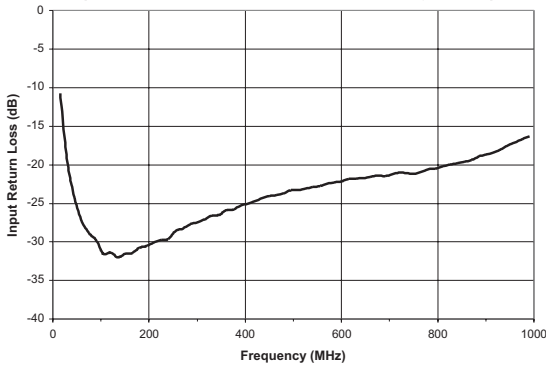

Figure 15: Output Return Loss vs. Frequency - S24 Packaged Device
($T_A = +25\text{ }^\circ\text{C}$, $V_{DD} = +8\text{ V}$, $75\ \Omega$ system)

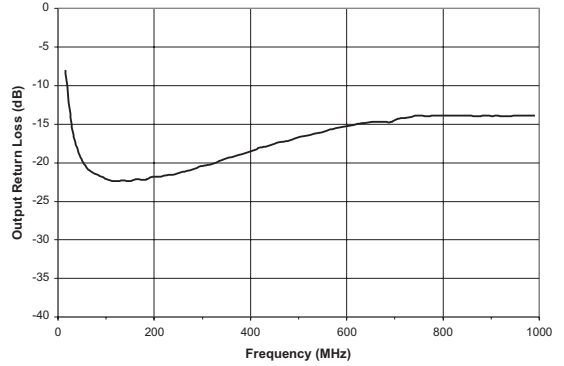

Figure 16: IIP2 and IIP3 vs. Supply Voltage - S24 Packaged Device
($T_A = +25\text{ }^\circ\text{C}$, $75\ \Omega$ system)

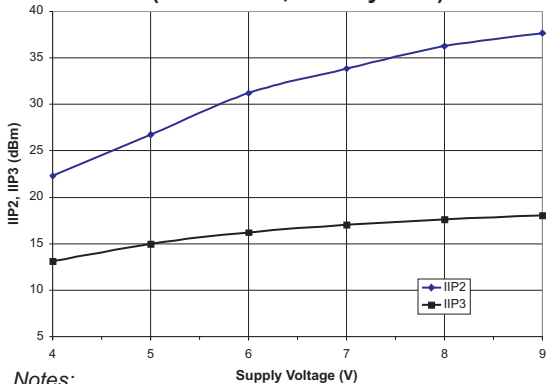
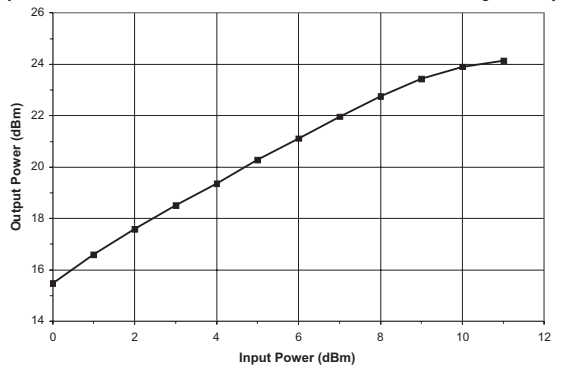

Figure 17: Output Power vs. Input Power S24 Packaged Device
($T_A = +25\text{ }^\circ\text{C}$, $V_{DD} = +8\text{ V}$, $f = 500\text{ MHz}$, $75\ \Omega$ system)



Notes:

1. IIP2 measured at 986.5 MHz; Input = two tones at 55.25 MHz and 931.25 MHz at -10 dBm.
2. IIP3 measured with two tones at the input: 986.5 MHz and 992.5 MHz at -10 dBm.

Figure 18: Unmatched Device Input Impedance
S24 Packaged Device

($T_A = +25\text{ }^\circ\text{C}$, $V_{DD} = +8\text{ V}$, $75\text{ }\Omega$ system)

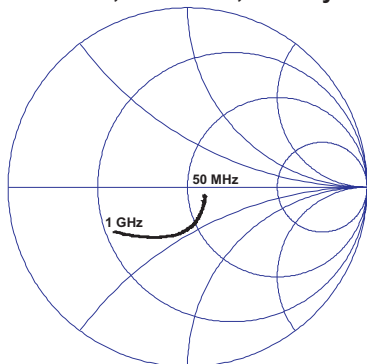
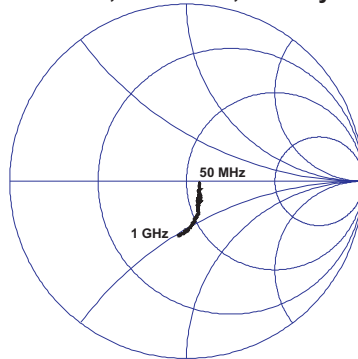

Figure 19: Unmatched Device Output Impedance
S24 Packaged Device

($T_A = +25\text{ }^\circ\text{C}$, $V_{DD} = +8\text{ V}$, $75\text{ }\Omega$ system)



Refer to the ANADIGICS web site for full 2-port s-parameter data.

PACKAGE OUTLINE

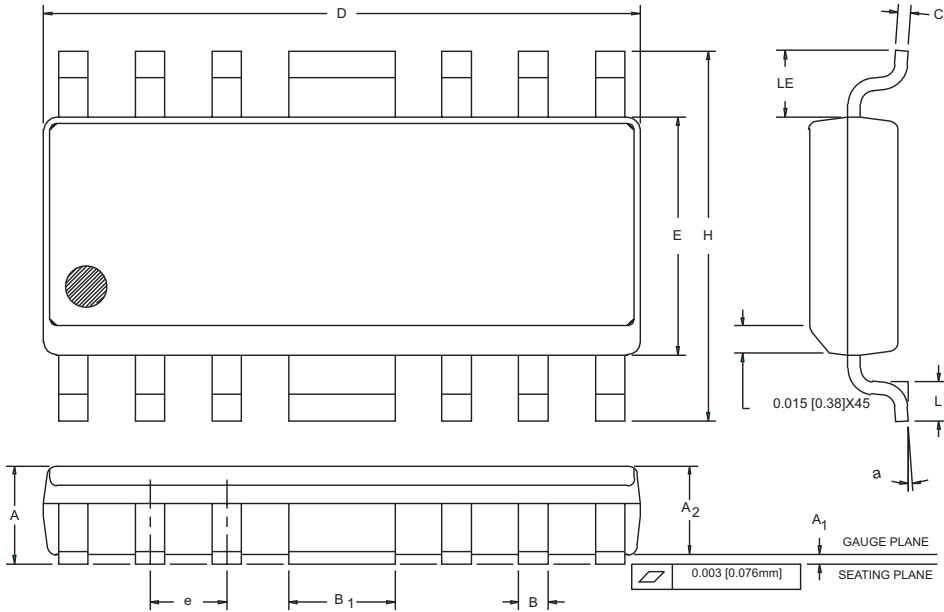

SYMBOL	INCHES		MILLIMETERS		NOTE
	MIN.	MAX.	MIN.	MAX.	
A	0.058	0.068	1.47	1.73	
A ₁	0.004	0.010	0.10	0.25	
A ₂	0.055	0.065	1.40	1.65	
B	0.013	0.020	0.33	0.50	
B ₁	0.062	0.070	1.58	1.78	
C	0.008	0.010	0.20	0.25	4
D	0.380	0.400	9.66	10.16	2
E	0.150	0.160	3.81	4.06	3
e	0.050 BSC		1.27 BSC		
H	0.226	0.244	5.74	6.20	
L	0.016	0.040	0.41	1.02	
LE	0.030	—	0.76	—	
a	0	8	0	8	

NOTES:

1. CONTROLLING DIMENSION: INCHES
2. DIMENSION "D" DOES NOT INCLUDE MOLD FLASH, PROTRUSIONS OR GATE BURRS. MOLD FLASH, PROTRUSIONS AND GATE BURRS SHALL NOT EXCEED 0.006 [0.15mm] PER SIDE.
3. DIMENSION "E" DOES NOT INCLUDE INTER-LEAD FLASH OR PROTRUSIONS. INTER-LEAD FLASH AND PROTRUSIONS SHALL NOT EXCEED 0.010 [0.25mm] PER SIDE.
4. LEAD THICKNESS AFTER PLATING TO BE 0.013 [0.33mm] MAXIMUM.

Figure 20: S3 Package Outline - Modified 16 Pin SOIC

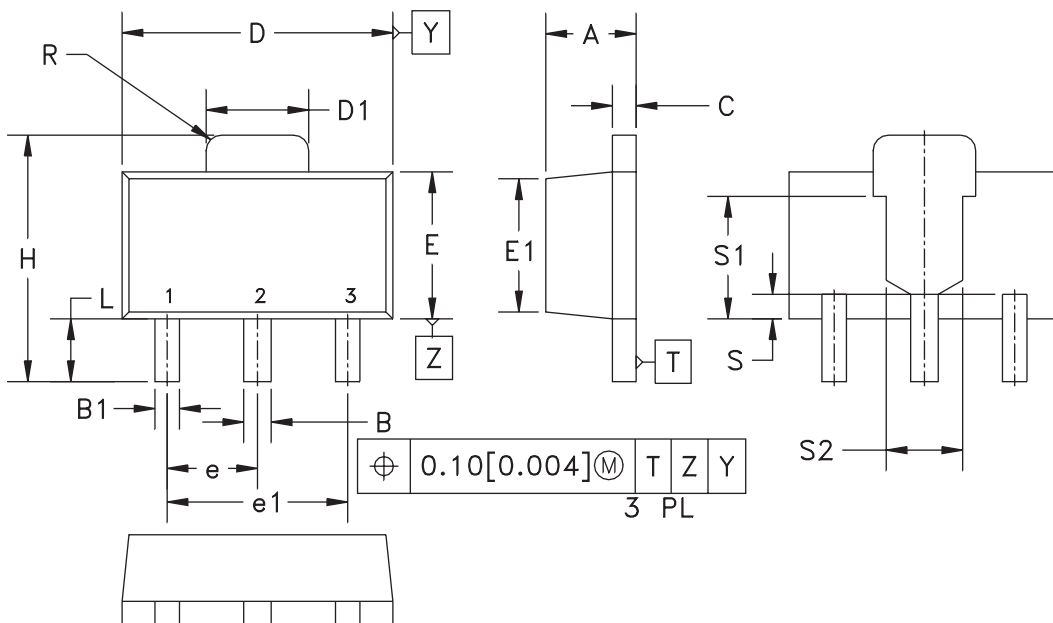

S _M B _{OL}	MILLIMETERS		INCHES		NOTE
	MIN.	MAX.	MIN.	MAX.	
A	1.40	1.60	0.055	0.063	-
B	0.44	0.56	0.017	0.022	-
B1	0.36	0.48	0.014	0.019	3
C	0.35	0.44	0.014	0.017	-
D	4.40	4.60	0.173	0.181	-
D1	1.62	1.83	0.064	0.072	-
E	2.29	2.60	0.090	0.102	-
E1	2.13	2.29	0.084	0.090	4
e	1.50 BSC		0.059 BSC		-
e1	3.00 BSC		0.118 BSC		-
H	3.94	4.25	0.155	0.167	-
L	0.89	1.20	0.035	0.047	-
R	-	0.25	-	0.010	-
S	0.40 NOM.		0.016 NOM.		4
S1	2.03 NOM.		0.080 NOM.		4
S2	1.27 NOM.		0.050 NOM.		4

NOTES:

1. CONTROLLING DIMENSIONS: MILLIMETERS.
2. DIMENSIONS DO NOT INCLUDE END FLASH, MOLD FLASH OR MATERIAL PROTRUSIONS.
3. DIMENSION B1, 2 PLACES.
4. DIMENSIONS E1, S, S1 & S2 - REFERENCE ONLY.
5. REFERENCE JEDEC TO-243 (AA).

Figure 21: S24 Package Outline - SOT-89

ORDERING INFORMATION

ORDER NUMBER	TEMPERATURE RANGE	PACKAGE DESCRIPTION	COMPONENT PACKAGING
ADA10000S3CTR	-40 °C to +85 °C	Modified 16 Pin SOIC	3,500 piece Tape and Reel
ADA10000S3C	-40 °C to +85 °C	Modified 16 Pin SOIC	Plastic tubes (50 pieces per tube)
ADA10000S24Q1	-40 °C to +85 °C	SOT-89 Package	1,000 piece Tape and Reel

**ANADIGICS, Inc.**141 Mount Bethel Road
Warren, New Jersey 07059, U.S.A.

Tel: +1 (908) 668-5000

Fax: +1 (908) 668-5132

URL: <http://www.anadigics.com>E-mail: Mktg@anadigics.com**IMPORTANT NOTICE**

ANADIGICS, Inc. reserves the right to make changes to its products or to discontinue any product at any time without notice. The product specifications contained in Advanced Product Information sheets and Preliminary Data Sheets are subject to change prior to a product's formal introduction. Information in Data Sheets have been carefully checked and are assumed to be reliable; however, ANADIGICS assumes no responsibilities for inaccuracies. ANADIGICS strongly urges customers to verify that the information they are using is current before placing orders.

WARNING

ANADIGICS products are not intended for use in life support appliances, devices or systems. Use of an ANADIGICS product in any such application without written consent is prohibited.

SUNSTAR 商斯达实业集团是集研发、生产、工程、销售、代理经销、技术咨询、信息服务等为一体的高科技企业，是专业高科技电子产品生产厂家，是具有 10 多年历史的专业电子元器件供应商，是中国最早和最大的仓储式连锁规模经营大型综合电子零部件代理分销商之一，是一家专业代理和分销世界各大品牌 IC 芯片和电子元器件的连锁经营综合性国际公司，专业经营进口、国产名厂名牌电子元件，型号、种类齐全。在香港、北京、深圳、上海、西安、成都等全国主要电子市场设有直属分公司和产品展示展销窗口门市部专卖店及代理分销商，已在全国范围内建成强大统一的供货和代理分销网络。我们专业代理经销、开发生产电子元器件、集成电路、传感器、微波光电元器件、工控机/DOC/DOM 电子盘、专用电路、单片机开发、MCU/DSP/ARM/FPGA 软件硬件、二极管、三极管、模块等，是您可靠的一站式现货配套供应商、方案提供商、部件功能模块开发配套商。商斯达实业公司拥有庞大的资料库，有数位毕业于著名高校——有中国电子工业摇篮之称的西安电子科技大学（西军电）并长期从事国防尖端科技研究的高级工程师为您精挑细选、量身订做各种高科技电子元器件，并解决各种技术问题。

微波光电部专业代理经销高频、微波、光纤、光电元器件、组件、部件、模块、整机；电磁兼容元器件、材料、设备；微波 CAD、EDA 软件、开发测试仿真工具；微波、光纤仪器仪表。欢迎国外高科技微波、光纤厂商将优秀产品介绍到中国、共同开拓市场。长期大量现货专业批发高频、微波、卫星、光纤、电视、CATV 器件：晶振、VCO、连接器、PIN 开关、变容二极管、开关二极管、低噪晶体管、功率电阻及电容、放大器、功率管、MMIC、混频器、耦合器、功分器、振荡器、合成器、衰减器、滤波器、隔离器、环行器、移相器、调制解调器；光电子器件和组件：红外发射管、红外接收管、光电开关、光敏管、发光二极管和发光二极管组件、半导体激光二极管和激光器组件、光电探测器和光接收组件、光发射接收模块、光纤激光器和光放大器、光调制器、光开关、DWDM 用光发射和接收器件、用户接入系统光收发器件与模块、光纤连接器、光纤跳线/尾纤、光衰减器、光纤适配器、光隔离器、光耦合器、光环行器、光复用器/转换器；无线收发芯片和模组、蓝牙芯片和模组。

更多产品请看本公司产品专用销售网站：

商斯达中国传感器科技信息网：<http://www.sensor-ic.com/>

商斯达工控安防网：<http://www.pc-ps.net/>

商斯达电子元器件网：<http://www.sunstare.com/>

商斯达微波光电产品网：[HTTP://www.rfoe.net/](http://www.rfoe.net/)

商斯达消费电子产品网：<http://www.icasic.com/>

商斯达实业科技产品网：<http://www.sunstars.cn/> 微波元器件销售热线：

地址：深圳市福田区福华路福庆街鸿图大厦 1602 室

电话：0755-82884100 83397033 83396822 83398585

传真：0755-83376182 (0) 13823648918 MSN: SUNS8888@hotmail.com

邮编：518033 E-mail:szss20@163.com QQ: 195847376

深圳赛格展销部：深圳华强北路赛格电子市场 2583 号 电话：0755-83665529 25059422

技术支持：0755-83394033 13501568376

欢迎索取免费详细资料、设计指南和光盘；产品凡多，未能尽录，欢迎来电查询。

北京分公司：北京海淀区知春路 132 号中发电子大厦 3097 号

TEL: 010-81159046 82615020 13501189838 FAX: 010-62543996

上海分公司：上海市北京东路 668 号上海赛格电子市场 D125 号

TEL: 021-28311762 56703037 13701955389 FAX: 021-56703037

西安分公司：西安高新开发区 20 所(中国电子科技集团导航技术研究所)

西安劳动南路 88 号电子商城二楼 D23 号

TEL: 029-81022619 13072977981 FAX:029-88789382