



# AMT8304

2.125 Gb/s Integrated 850nm MSM-TIA  
PRELIMINARY DATA SHEET - Rev 1.1

## FEATURES

- Differential Output TIA
- 3.3V Operation
- Automatic Gain Control
- Integrated 850nm MSM Detector & TIA
- TO-46 Ultra Flat-Window or Lens Hermetic Package
- High Reliability

## APPLICATIONS

- 2x Fibre Channel (2.125 Gb/s)

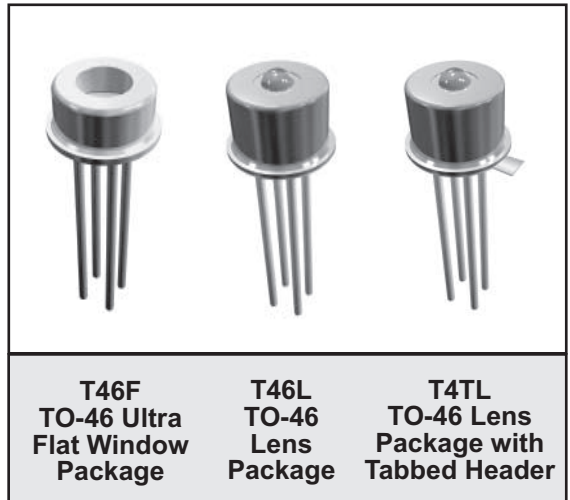

## PRODUCT DESCRIPTION

The ANADIGICS AMT8304 is a 3.3V monolithically integrated Metal-Semiconductor-Metal (MSM) photodetector and transimpedance amplifier (TIA) used to convert an 850nm input optical signal into a differential output voltage, and is manufactured in ANADIGICS' 6" GaAs wafer fabrication facility. The integrated MSM and TIA receiver maximizes the receiver performance by minimizing the photodetector input parasitics to the TIA and

internally biasing the photodetector to achieve high sensitivity, bandwidth and overload performance. As an integrated product the reliability is inherently better than a discrete solution, and both the MSM-TIA integrated circuit and TO-46 flat window and TO-46 lens packaged receiver pass stringent reliability requirements. These products are readily designed into receivers and transceivers for 2x Fibre Channel applications.

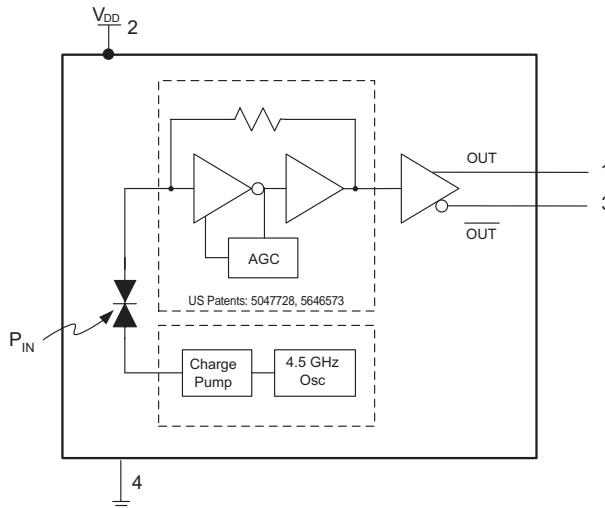

Figure 1: Equivalent Circuit

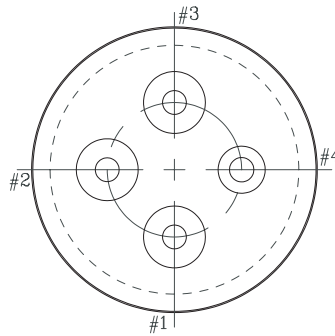

Figure 2: T46F/T46L/T4TL Pin Outline (Bottom View)

Table 1: Package PIN Description

PIN	DESCRIPTION	COMMENT
1	$V_{OUT}$ - TIA Output Voltage (non-Inverted)	Logical '1' with optical input
2	$V_{DD}$ - Positive Supply Voltage	+3.3 Volts
3	$\overline{V_{OUT}}$ - TIA Output Voltage (Inverted)	Logical '0' with optical input
4	Ground	Case is grounded

ELECTRICAL CHARACTERISTICS

Table 2: Absolute Maximum Ratings

$V_{DD}$	6.0V
$P_{IN}$	+5dBm
$T_S$	Storage Temp. -65 °C to 125 °C

Stresses in excess of the absolute ratings may cause permanent damage. Functional operation is not implied under these conditions. Exposure to absolute ratings for extended periods of time may adversely affect reliability.

**Table 3: Electrical Characteristics**

PARAMETER	MIN	TYP	MAX	UNIT
Wavelength ( $\lambda$ )	770	850	860	nm
Detector Diameter	-	100	-	$\mu\text{m}$
Small Signal Differential Responsivity <sup>(1)</sup> (@ 50 MHz)	1000	-	-	V/W
Bandwidth <sup>(1)</sup>	1400	1900	-	MHz
Low Frequency Cutoff	-	-	300	KHz
Output Resistance	-	40	-	
Optical Overload <sup>(2)</sup>	0	-	-	dBm
Optical Sensitivity <sup>(2)</sup>	-19	-	-	dBm
Differential Output Voltage <sup>(3)</sup>	-	750	-	mV
T <sub>RISE</sub> and T <sub>FALL</sub> (20-80%) <sup>(3)</sup>	-	140	-	ps
Duty Cycle Distortion <sup>(3)</sup>	-	5	-	%
Total Jitter <sup>(3),(4)</sup>	-	50	-	ps
Supply Current	-	35	55	mA
Operating Voltage Range	+3.0	+3.3	+3.6	Volts
Operating Case Temperature Range	0	-	80	$^{\circ}\text{C}$

**Notes:**

- (1) Measured at  $-14$  dBm optical input power with output connected into  $R_L = 100\Omega$  (differential)
- (2) Measured at  $10^{-10}$  BER with a  $2^7-1$  PRBS at 2.125 Gb/s
- (3) Measured with a  $2^7-1$  PRBS at 2.125 Gb/s, an input optical power of  $-3\text{dBm}$  and  $R_L = 100\Omega$  (differential)
- (4)  $6\sigma$  about the center eye crossing

PERFORMANCE DATA

Figure 3: Eye Diagram with an Optical Input Power of  $-19\text{dBm}$  (with a 4GHz LPF)

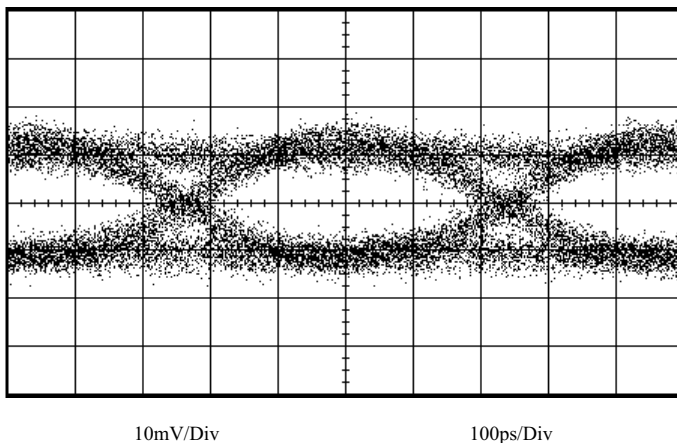

Figure 4: Eye Diagram with an Optical Input Power of  $-9.0\text{dBm}$

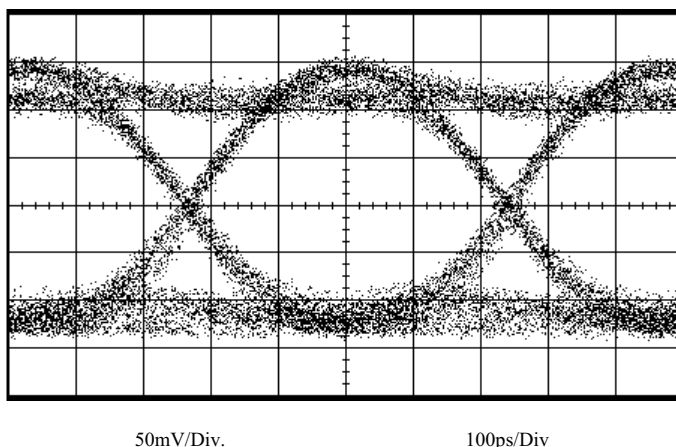

Figure 5: Eye Diagram with an Optical Input Power of  $0\text{dBm}$

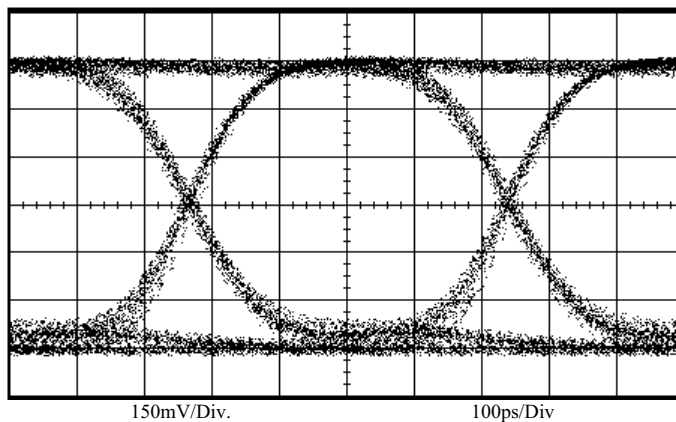

Figure 6: Supply Current vs. Temperature

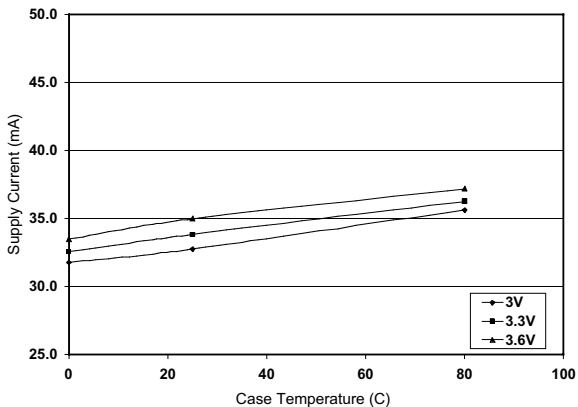

Figure 7: Bandwidth vs. Temperature

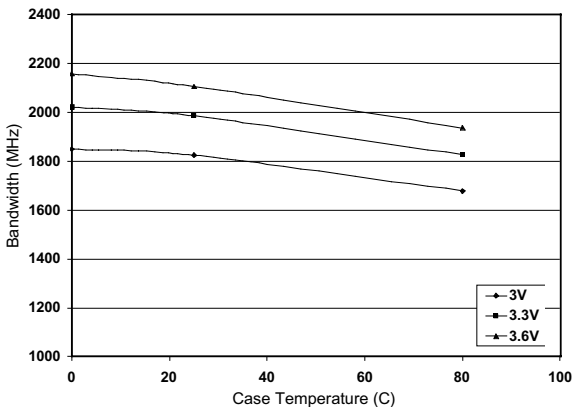

Figure 8: Differential Responsivity vs. Temperature

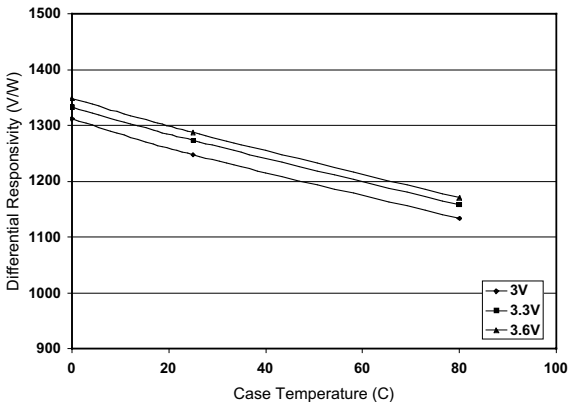
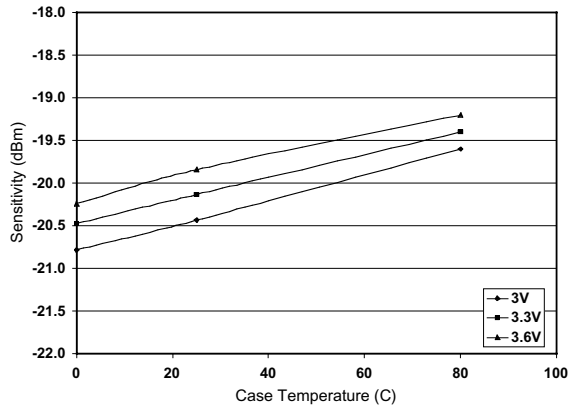

Figure 9: Sensitivity vs. Temperature



MEASUREMENT METHODS

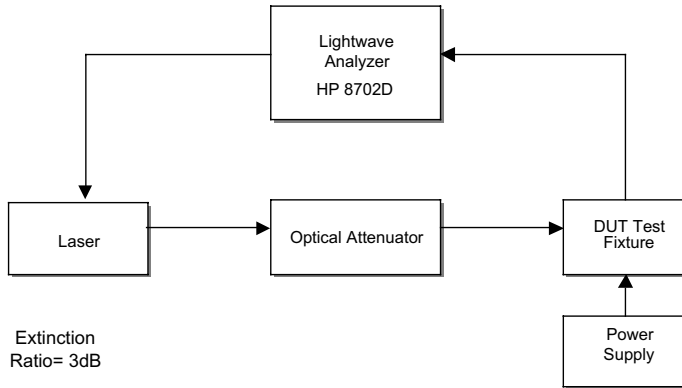

Figure 11: Test Setup for Frequency Response

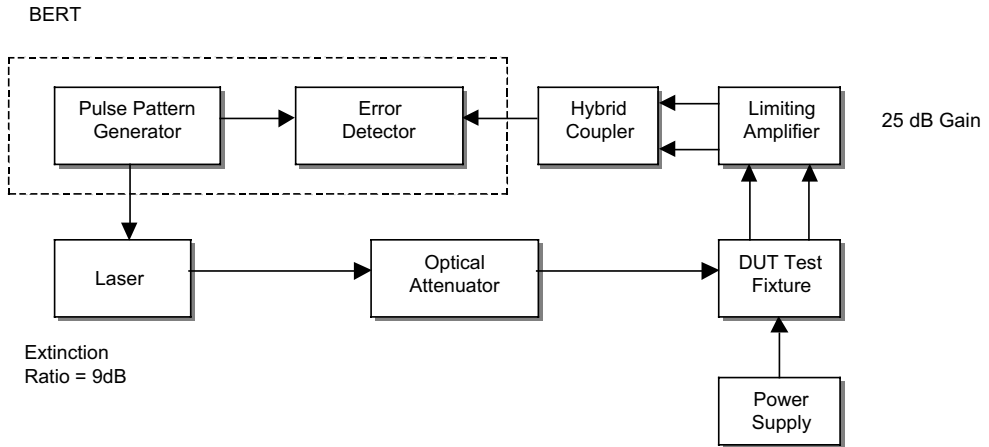

Figure 12: Test Setup for Sensitivity

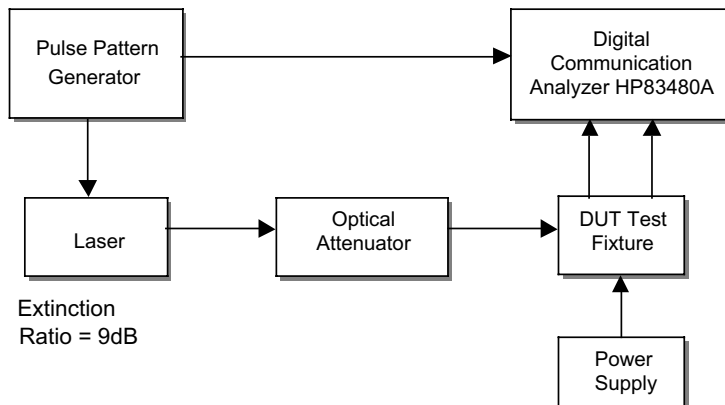

Figure 13: Test Setup for Eye Measurements

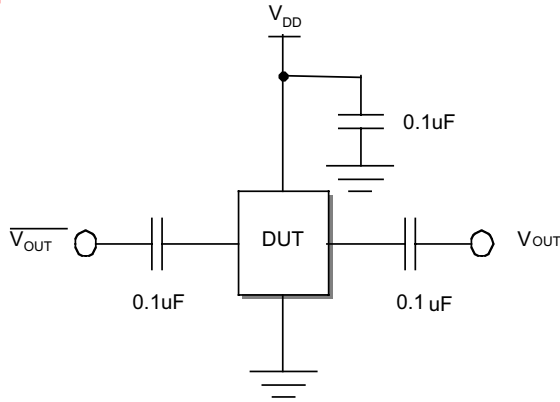

Figure 13: DUT Test Fixture Schematic

APPLICATION INFORMATION

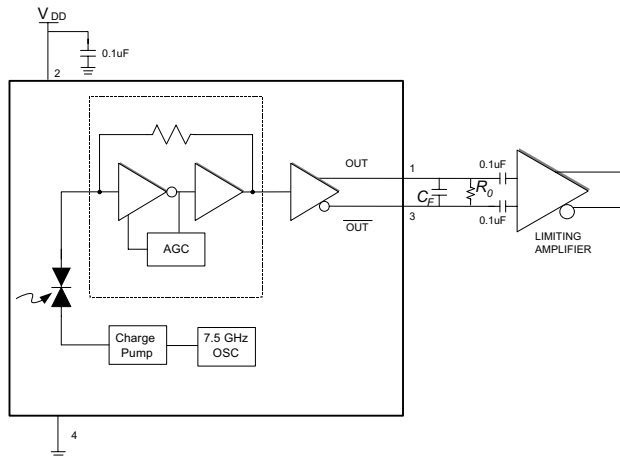

Figure 14: Application Schematic

$C_F$  is an optional single pole noise filter

$$C_F = \frac{1}{2\pi f_c R}$$

$f_c$  is the desired cutoff frequency

$$R = 50 \Omega$$

$R_O$  is required with high input resistance limiting amplifiers

$$R_O = 100 \Omega$$

PACKAGE OUTLINE

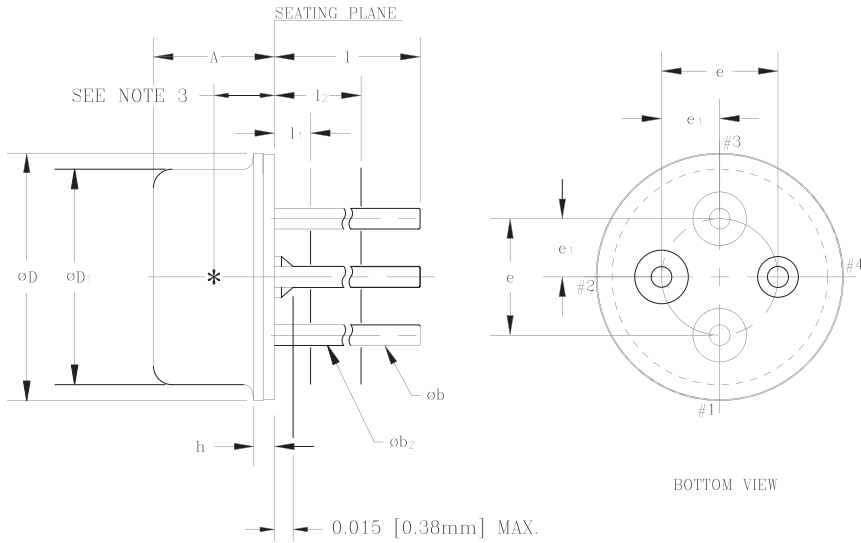

MM CONTROLLING DIMENSIONS

S <sub>W</sub> P <sub>OL</sub>	INCHES		MILLIMETERS		NOTE
	MIN.	MAX.	MIN.	MAX.	
A	0.098	0.110	2.50	2.80	
øb	0.016	0.020	0.41	0.51	1
øb <sub>2</sub>	0.012	0.019	0.30	0.48	1
øD	0.212	0.218	5.38	5.54	
øD	0.181	0.187	4.60	4.75	
e	0.100 T.P.		2.54 T.P.		2
e <sub>1</sub>	0.050 T.P.		1.27 T.P.		2
h	0.014	0.022	0.36	0.56	
l	0.500	0.540	12.70	13.70	1
l <sub>1</sub>	—	0.050	—	1.27	1
l <sub>2</sub>	0.250	—	6.35	—	1

NOTES:

- (FOUR LEADS) øb<sub>2</sub> APPLIES BETWEEN l<sub>1</sub> AND l<sub>2</sub>. øb APPLIES BETWEEN l<sub>2</sub> AND 0.5 [12.70mm] FROM SEATING PLANE. DIAMETER IS UNCONTROLLED IN l<sub>1</sub> AND BEYOND 0.5 [12.70mm] TO END OF PIN.
- MAXIMUM DIAMETER LEADS AT A GAGING PLANE 0.054 [1.37mm]+0.001 [0.025mm] -0.000 [0.000mm] BELOW SEATING PLANE TO BE WITHIN 0.007 [0.178mm] OF THEIR TRUE POSITION RELATIVE TO MAXIMUM-WIDTH TAB AND TO THE MAXIMUM 0.212 [5.40mm] DIAMETER MEASURED WITH A SUITABLE GAGE. WHEN GAGE IS NOT USED, MEASUREMENT WILL BE MADE AT 0.250 [6.35mm] FROM SEATING PLANE.
- INTERNAL OPTICAL HEIGHT = 0.052±0.003[1.31±.08]
- BENT LEADS SHOULD NOT EXTEND OUTSIDE DIAMETER (øD) OF CAP OR TOUCH EACH OTHER.
- ALL DIMENSIONS ARE REFERENCE ONLY—EXCEPT A, D & h.
- DETECTOR DIODE PLACEMENT ACCURACY ⊕0.15MM[0.006] WITH RESPECT TO CENTER OF HEADER.(REF.ONLY)

Figure 15: T46F Package Outline Diagram



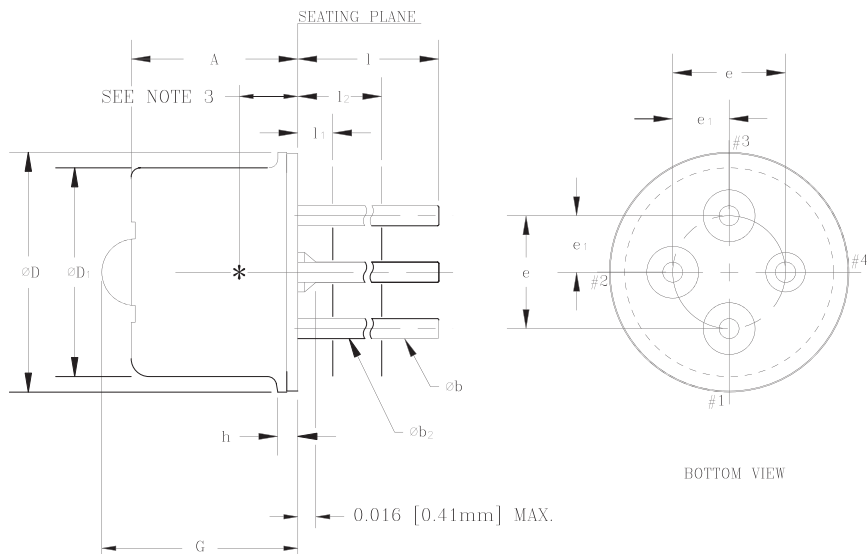

MM CONTROLLING DIMENSIONS

SYMBOL	INCHES		MILLIMETERS		NOTE
	MIN.	MAX.	MIN.	MAX.	
A	--	0.160	--	4.00	
$\phi b$	0.016	0.020	0.41	0.51	1
$\phi b_2$	0.012	0.019	0.30	0.48	1
$\phi D$	0.212	0.218	5.38	5.54	
$\phi D_1$	0.181	0.187	4.60	4.75	
e	0.100 T.P.		2.54 T.P.		2
e1	0.050 T.P.		1.27 T.P.		2
h	0.014	0.022	0.36	0.56	
l	0.500	0.540	12.70	13.70	1
l1	--	0.050	--	1.27	1
l2	0.250	--	6.35	--	1
G	--	0.190	--	4.66	7

NOTES:

1. (FOUR LEADS)  $\phi b_2$  APPLIES BETWEEN  $l_1$  AND  $l_2$ .  $\phi b$  APPLIES BETWEEN  $l_2$  AND 0.5 [12.70mm] FROM SEATING PLANE. DIAMETER IS UNCONTROLLED IN  $l_1$  AND BEYOND 0.5 [12.70mm] TO END OF PIN.
2. MAXIMUM DIAMETER LEADS AT A GAGING PLANE 0.054 [1.37mm]+0.001 [0.025mm] -0.000 [0.000mm] BELOW SEATING PLANE TO BE WITHIN 0.007 [0.178mm] OF THEIR TRUE POSITION RELATIVE TO MAXIMUM-WIDTH TAB AND TO THE MAXIMUM 0.212 [5.40mm] DIAMETER MEASURED WITH A SUITABLE GAGE. WHEN GAGE IS NOT USED, MEASUREMENT WILL BE MADE AT 0.250 [6.35mm] FROM SEATING PLANE.
3. INTERNAL OPTICAL HEIGHT =  $0.052 \pm 0.003$  [1.32  $\pm$  0.08] DIE PLACEMENT ACCURACY FOR REF. ONLY.
4. BENT LEADS SHOULD NOT EXTEND OUTSIDE DIAMETER ( $\phi D$ ) OF CAP OR TOUCH EACH OTHER.
5. ALL DIMENSIONS ARE REFERENCE ONLY—EXCEPT A, D & h.
6. DETECTOR DIODE PLACEMENT ACCURACY  $\pm 0.15$ MM [0.006] ALL DIRECTIONS
7. LENS HEIGHT =  $0.65 \pm 0.1$  [0.026  $\pm$  0.004]

Figure 16: T46L Package Outline Diagram

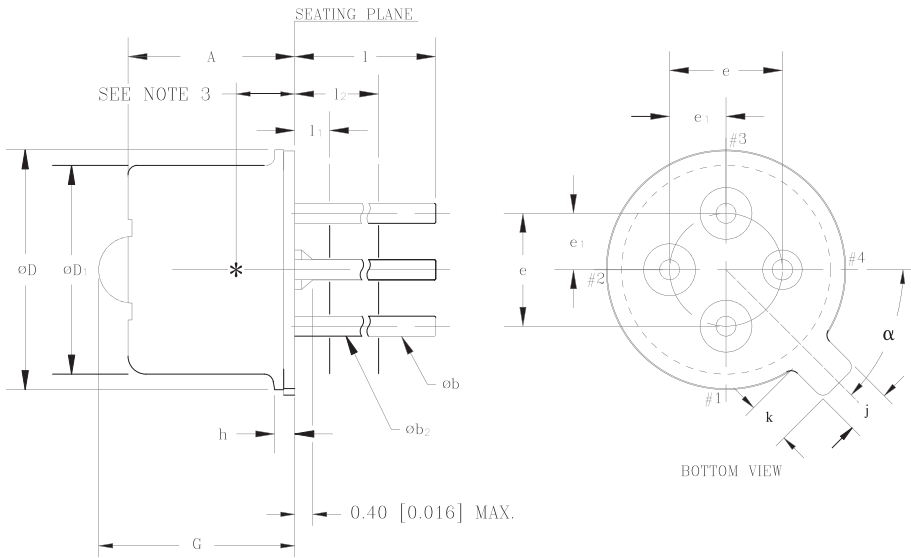

MM CONTROLLING DIMENSIONS

SYMBOL	MILLIMETERS		INCHES		NOTE
	MIN.	MAX.	MIN.	MAX.	
A	--	4.00	--	0.160	
ob	0.41	0.51	0.016	0.020	1
ob2	0.30	0.48	0.012	0.019	1
oD	5.38	5.54	0.212	0.218	
oD1	4.60	4.75	0.181	0.187	
e	2.54	T.P.	0.100	T.P.	2
e1	1.27	T.P.	0.050	T.P.	2
h	0.36	0.56	0.014	0.022	
j	0.92	1.12	0.036	0.044	
k	0.81	1.04	0.032	0.041	
l	12.70	13.70	0.500	0.540	1
l1	--	1.27	--	0.050	1
l2	6.35	--	0.250	--	1
G	--	4.66	--	0.190	7
alpha	45°	T.P.	45°	T.P.	

NOTES:

- (FOUR LEADS) ob<sub>2</sub> APPLIES BETWEEN l<sub>1</sub> AND l<sub>2</sub>. ob APPLIES BETWEEN l<sub>2</sub> AND 12.70 [0.50] FROM SEATING PLANE. DIAMETER IS UNCONTROLLED IN l<sub>1</sub> AND BEYOND 12.70 [0.50] TO END OF PIN.
- MAXIMUM DIAMETER LEADS AT A GAGING PLANE 1.37 +0.025/-0.000 [0.054+0.001/-0.000] BELOW SEATING PLANE TO BE WITHIN 0.178 [0.007] OF THEIR TRUE POSITION RELATIVE TO MAXIMUM-WIDTH TAB AND TO THE MAXIMUM 5.40 [0.212] DIAMETER MEASURED WITH A SUITABLE GAGE. WHEN GAGE IS NOT USED, MEASUREMENT WILL BE MADE AT 6.35 [0.25] FROM SEATING PLANE.
- INTERNAL OPTICAL HEIGHT = 1.32±0.08 [0.052±0.003] DIE PLACEMENT ACCURACY FOR REF. ONLY.
- BENT LEADS SHOULD NOT EXTEND OUTSIDE DIAMETER (oD) OF CAP OR TOUCH EACH OTHER.
- ALL DIMENSIONS ARE REFERENCE ONLY—EXCEPT A, D & h.
- DETECTOR DIODE PLACEMENT ACCURACY ±0.15 [0.006] ALL DIRECTIONS
- LENS HEIGHT = 0.65±0.1 [0.026±0.004]

Figure 17: T4TL Package Outline Diagram

NOTES

**ORDERING INFORMATION**

ORDER NUMBER	PACKAGE OPTION	PACKAGE DESCRIPTION
AMT8304T46F	TO-46F	Ultra Flat Window Package
AMT8304T46L	TO-46L	Lens Package
AMT8304T4TL	TO-46L	Lens Package with Tabbed Header



**ANADIGICS, Inc.**  
 141 Mount Bethel Road  
 Warren, New Jersey 07059, U.S.A.  
 Tel: +1 (908) 668-5000  
 Fax: +1 (908) 668-5132

URL: <http://www.anadigics.com>  
 E-mail: [Mktg@anadigics.com](mailto:Mktg@anadigics.com)

**IMPORTANT NOTICE**

ANADIGICS, Inc. reserves the right to make changes to its products or to discontinue any product at any time without notice. The product specifications contained in Advanced Product Information sheets and Preliminary Data Sheets are subject to change prior to a product's formal introduction. Information in Data Sheets have been carefully checked and are assumed to be reliable; however, ANADIGICS assumes no responsibilities for inaccuracies. ANADIGICS strongly urges customers to verify that the information they are using is current before placing orders.

**WARNING**

ANADIGICS products are not intended for use in life support appliances, devices or systems. Use of an ANADIGICS product in any such application without written consent is prohibited.

SUNSTAR 商斯达实业集团是集研发、生产、工程、销售、代理经销、技术咨询、信息服务等为一体的高科技企业，是专业高科技电子产品生产厂家，是具有 10 多年历史的专业电子元器件供应商，是中国最早和最大的仓储式连锁规模经营大型综合电子零部件代理分销商之一，是一家专业代理和分销世界各大品牌 IC 芯片和电子元器件的连锁经营综合性国际公司，专业经营进口、国产名厂名牌电子元件，型号、种类齐全。在香港、北京、深圳、上海、西安、成都等全国主要电子市场设有直属分公司和产品展示展销窗口门市部专卖店及代理分销商，已在全国范围内建成强大统一的供货和代理分销网络。我们专业代理经销、开发生产电子元器件、集成电路、传感器、微波光电元器件、工控机/DOC/DOM 电子盘、专用电路、单片机开发、MCU/DSP/ARM/FPGA 软件硬件、二极管、三极管、模块等，是您可靠的一站式现货配套供应商、方案提供商、部件功能模块开发配套商。商斯达实业公司拥有庞大的资料库，有数位毕业于著名高校——有中国电子工业摇篮之称的西安电子科技大学（西军电）并长期从事国防尖端科技研究的高级工程师为您精挑细选、量身订做各种高科技电子元器件，并解决各种技术问题。

微波光电部专业代理经销高频、微波、光纤、光电元器件、组件、部件、模块、整机；电磁兼容元器件、材料、设备；微波 CAD、EDA 软件、开发测试仿真工具；微波、光纤仪器仪表。欢迎国外高科技微波、光纤厂商将优秀产品介绍到中国、共同开拓市场。长期大量现货专业批发高频、微波、卫星、光纤、电视、CATV 器件：晶振、VCO、连接器、PIN 开关、变容二极管、开关二极管、低噪晶体管、功率电阻及电容、放大器、功率管、MMIC、混频器、耦合器、功分器、振荡器、合成器、衰减器、滤波器、隔离器、环行器、移相器、调制解调器；光电子元件和组件：红外发射管、红外接收管、光电开关、光敏管、发光二极管和发光二极管组件、半导体激光二极管和激光器组件、光电探测器和光接收组件、光发射接收模块、光纤激光器和光放大器、光调制器、光开关、DWDM 用光发射和接收器件、用户接入系统光收发器件与模块、光纤连接器、光纤跳线/尾纤、光衰减器、光纤适配器、光隔离器、光耦合器、光环行器、光复用器/转换器；无线收发芯片和模组、蓝牙芯片和模组。

更多产品请看本公司产品专用销售网站：

商斯达中国传感器科技信息网：<http://www.sensor-ic.com/>

商斯达工控安防网：<http://www.pc-ps.net/>

商斯达电子元器件网：<http://www.sunstare.com/>

商斯达微波光电产品网：[HTTP://www.rfoe.net/](http://www.rfoe.net/)

商斯达消费电子产品网：<http://www.icasic.com/>

商斯达实业科技产品网：<http://www.sunstars.cn/> 微波元器件销售热线：

地址：深圳市福田区福华路福庆街鸿图大厦 1602 室

电话：0755-82884100 83397033 83396822 83398585

传真：0755-83376182 (0) 13823648918 MSN: SUNS8888@hotmail.com

邮编：518033 E-mail:szss20@163.com QQ: 195847376

深圳赛格展销部：深圳华强北路赛格电子市场 2583 号 电话：0755-83665529 25059422

技术支持：0755-83394033 13501568376

欢迎索取免费详细资料、设计指南和光盘；产品凡多，未能尽录，欢迎来电查询。

北京分公司：北京海淀区知春路 132 号中发电子大厦 3097 号

TEL: 010-81159046 82615020 13501189838 FAX: 010-62543996

上海分公司：上海市北京东路 668 号上海赛格电子市场 D125 号

TEL: 021-28311762 56703037 13701955389 FAX: 021-56703037

西安分公司：西安高新开发区 20 所(中国电子科技集团导航技术研究所)

西安劳动南路 88 号电子商城二楼 D23 号

TEL: 029-81022619 13072977981 FAX:029-88789382