



# ATA01502

## AGC Transimpedance Amplifier SONET OC-3 PRELIMINARY DATA SHEET-Rev 2

### FEATURES

- Single +5 Volt Supply
- Automatic Gain Control
- -41 dBm Sensitivity
- 0 dBm Optical Overload
- 120 MHz Bandwidth

### APPLICATIONS

- SONET OC-3/SDH STM-1 (155 Mb/s) Receiver
- FDDI, Ethernet Fiber LAN
- Low Noise RF Amplifier

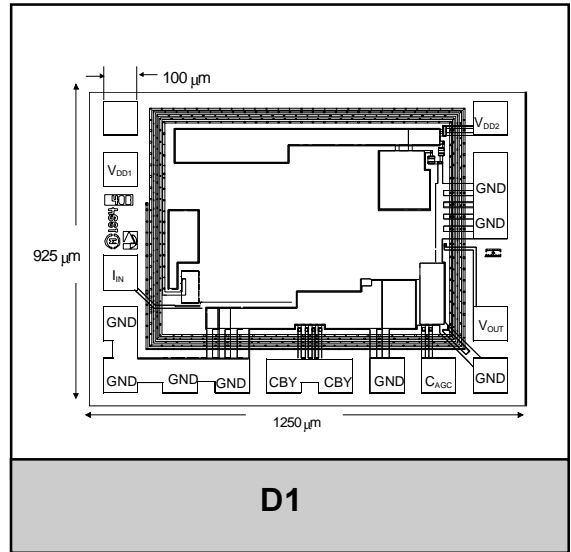

### PRODUCT DESCRIPTION

The ANADIGICS ATA01502 is a 5V low noise transimpedance amplifier with AGC designed to be used in OC-3/STM-1 fiber optic links. The device is used in conjunction with a photodetector (PIN diode or avalanche photodiode) to convert an optical signal

into an output voltage. The ATA01502 offers a bandwidth of 120MHz and a dynamic range of 42dB. It is manufactured in a GaAs MESFET process and is available in bare die form.

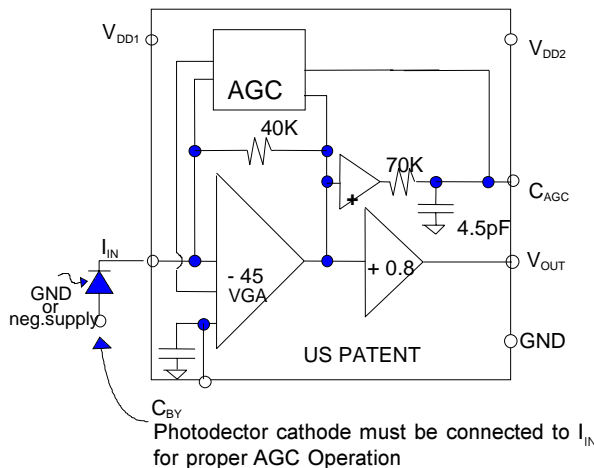

Figure 1: Equivalent Circuit

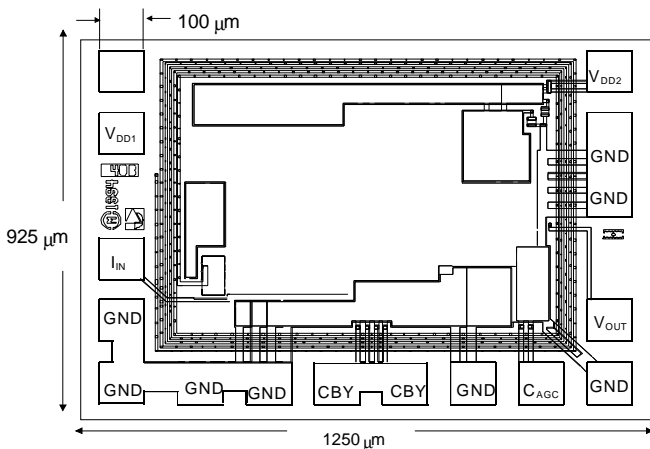

Figure 2: Bonding Pad Layout

Table 1: Pad Description

PAD	Description	Comment
$V_{DD1}$	$V_{DD1}$	Positive supply for input gain stage
$V_{DD2}$	$V_{DD2}$	Positive supply for second gain stage
$I_{IN}$	TIA Input Current	Connect detector cathode for proper operation
$V_{OUT}$	TIA Output Voltage	Requires external DC block
$C_{AGC}$	External AGC Capacitor	$70K^* (4.5p + CAGC) = AGC \text{ Time Constant}$
$C_{BY}$	Input Gain Stage Bypass Capacitor	$>56 \text{ pF}$

## ELECTRICAL CHARACTERISTICS

Table 2: Absolute Maximum Ratings

$V_{DD1}$	7.0 V
$V_{DD2}$	7.0 V
$I_{IN}$	5 mA
$T_A$	Operating Temp. - 40 °C to 125 °C
$T_S$	Storage Temp. - 65 °C to 150 °C

Stresses in excess of the absolute ratings may cause permanent damage. Functional operation is not implied under these conditions. Exposure to absolute ratings for extended periods of time may adversely affect reliability.

**Table 3: Electrical Specifications** <sup>(1)</sup>

( $T_A = 25^\circ\text{C}$ ,  $V_{DD} = +5.0\text{V} \pm 10\%$ ,  $C_{\text{DIODE}} + C_{\text{STRAY}} = 0.5 \text{ pF}$ , Det. cathode to  $I_{\text{IN}}$ )

PARAMETER	MIN	TYP	MAX	UNIT
Transresistance ( $R_L = \infty, I_{\text{DC}} < 500\text{nA}$ )	20	30		$\text{K}\Omega$
Transresistance ( $R_L = 50\Omega$ ) <sup>(1)</sup>	9.5	13	10	$\text{K}\Omega$
Bandwidth -3dB	110	120		MHz
Input Resistance <sup>(2)</sup>		1000		$\Omega$
Output Resistance	30	50	60	$\Omega$
Supply Current		30	45	mA
Input Offset Voltage	1.0	1.4		Volts
Output Offset Voltage		1.4		Volts
AGC Threshold ( $I_{\text{IN}}$ ) <sup>(3)</sup>		15		$\mu\text{A}$
Optical Overload <sup>(4)</sup>	0	1		dBm
Input Noise Current <sup>(5)</sup>		12		nA
AGC Time Constant <sup>(6)</sup>		16		$\mu\text{sec}$
Offset Voltage Drift		1		$\text{mV}/^\circ\text{C}$
Optical Sensitivity <sup>(7)</sup>		-41		dBm
Operating Voltage Range	+ 4.5	+ 5.0	+ 6.0	Volts
Operating Temperature Range	- 40		85	$^\circ\text{C}$
Thermal Resistance		20		$^\circ\text{C}/\text{W}$

Notes:

1.  $f = 50\text{MHz}$
2. Measured with  $I_{\text{in}}$  below AGC Threshold. During AGC, input impedance will decrease proportionally to  $I_{\text{in}}$ .
3. Defined as the  $I_{\text{in}}$  where Transresistance has decreased by 50%.
4. See note on "Indirect Measurement of Optical Overload."
5. See note on "Measurement of Input Referred Noise Current."
6.  $C_{\text{AGC}} = 220 \text{ pF}$
7. Parameter is guaranteed (not tested) by design and characterization data @155 Mb/s, assuming detector responsivity of 0.95.

## APPLICATION INFORMATION

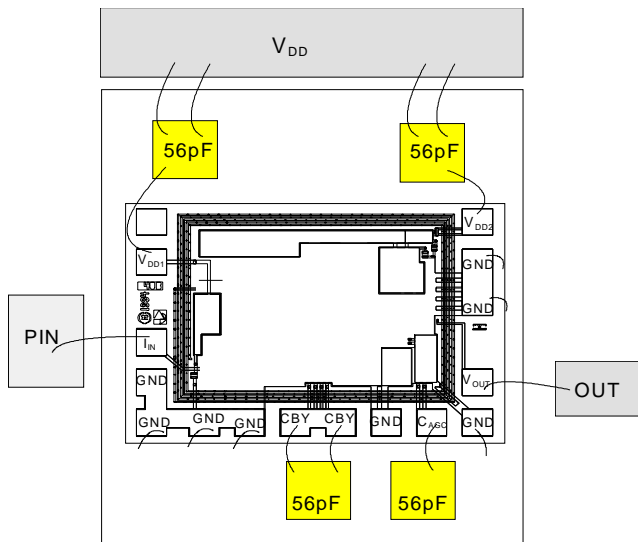

Figure 3: ATA 01502D1C Typical Bonding Diagram

**Power Supplies and General Layout Considerations**

The ATA01502D1C may be operated from a positive supply as low as + 4.5 V and as high as + 6.0 V. Below + 4.5 V, bandwidth, overload and sensitivity will degrade, while at + 6.0 V, bandwidth, overload and sensitivity improve (see "Bandwidth vs. Temperature" curves). Use of surface mount (preferably MIM type capacitors), low inductance power supply bypass capacitors ( $\geq 56\text{pF}$ ) are essential for good high frequency and low noise performance. The power supply bypass capacitors should be mounted on or connected to a good low inductance ground plane.

**General Layout Considerations**

Since the gain stages of the transimpedance amplifier have an open loop bandwidth in excess of 1.0 GHz, it is essential to maintain good high frequency layout practices. To prevent oscillations, a low inductance RF ground plane should be made available for power supply bypassing. Traces that can be made short should be made short. The utmost care should be taken to maintain very low capacitance at the photodiode TIA interface ( $I_{IN}$ ), as excess capacitance at this node will cause a degradation in

bandwidth and sensitivity (see Bandwidth vs.  $C_T$  curves).

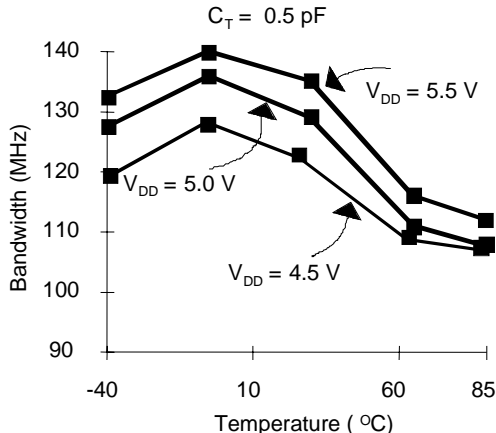
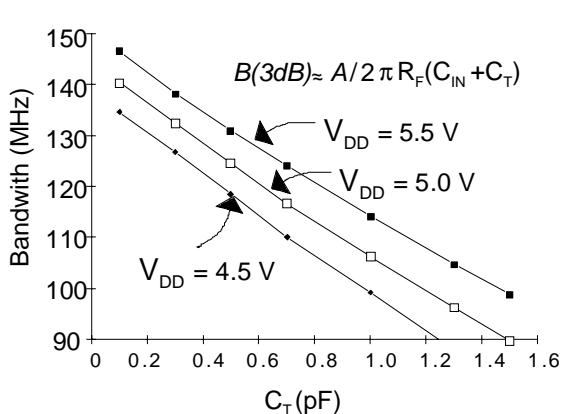
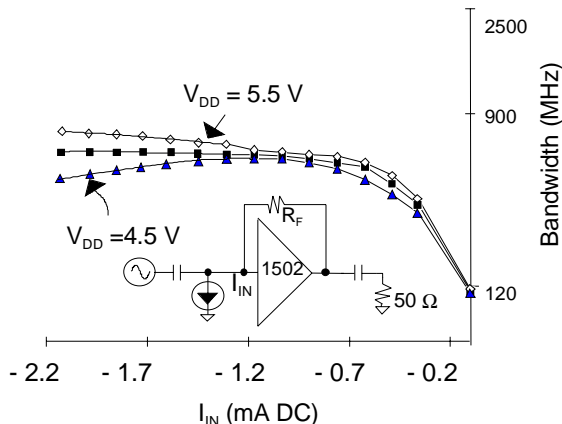

Figure 4: Bandwidth vs. Temperature



**Figure 5: Bandwidth vs. CT**

Note: All performance curves are typical @  $T_A = 25^\circ C$  unless otherwise noted.



**Figure 7: Bandwidth vs. IIN**

**IIN Connection**

(Refer to the equivalent circuit diagram) Bonding the detector cathode to  $I_{IN}$  (and thus drawing current from the ATA01502D1C) improves the dynamic range. The detector may be used in the reverse direction for input currents not exceeding 13  $\mu A$ , however the specifications for optical overload will not be met.

**VOUT Connection**

The output pad should be connected via a coupling capacitor to the next stage of the receiver channel (filter or decision circuits), as the output buffers are not designed to drive a DC coupled 50 ohm load (this would require an output bias current of approximately 36 mA to maintain a quiescent 1.8 Volts across the output load). If  $V_{OUT}$  is connected to a high input impedance decision circuit (>500 ohms), then a coupling capacitor may not be required, although caution should be exercised since DC offsets of the photo detector/TIA combination may cause clipping of subsequent gain or decision circuits.

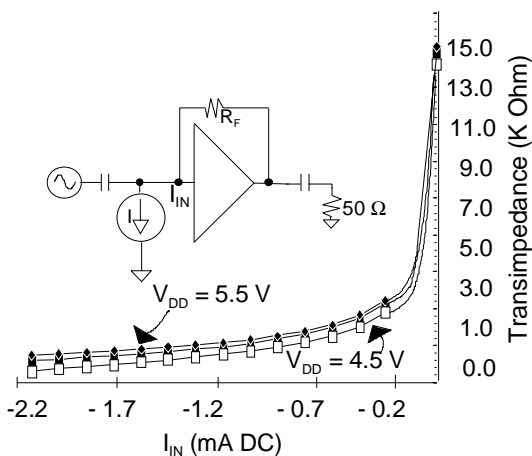

**Figure 6: Transimpedance vs. IIN**

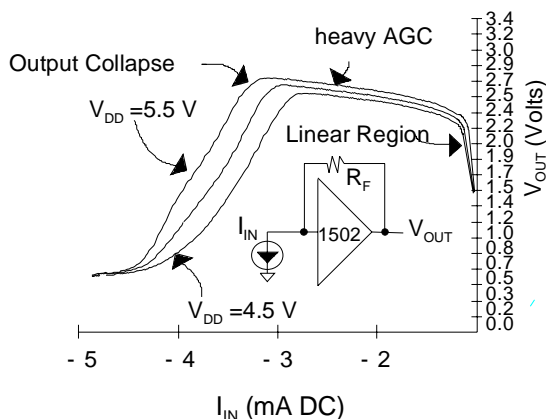

**Figure 8: VOUT vs. IIN**

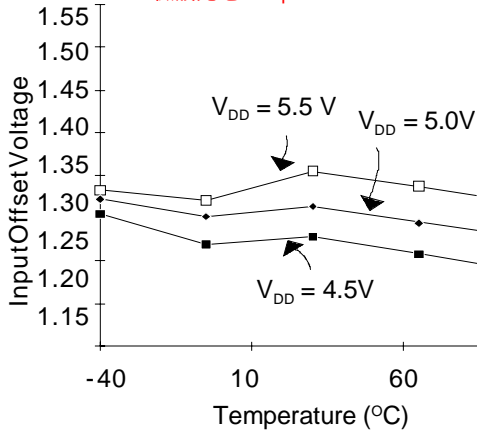

Figure 9: Input Offset Voltage vs. Temperature

### C<sub>BY</sub> Connection

The C<sub>BY</sub> pad must be connected via a low inductance path to a surface mount capacitor of at least 56pF (additional capacitance can be added in parallel with the 56 pF or 220 pF capacitors to improve low frequency response and noise performance). Referring to the equivalent circuit diagram and the typical bonding diagram, it is critical that the connection from C<sub>BY</sub> to the bypass capacitor use two bond wires for low inductance, since any high frequency impedance at this node will be fed back to the open loop amplifier with a resulting loss of transimpedance bandwidth. Two pads are provided for this purpose.

### Sensitivity and Bandwidth

In order to guarantee sensitivity and bandwidth performance, the TIA is subjected to a comprehensive series of tests at the die sort level (100% testing at 25 °C) to verify the DC parametric performance and the high frequency performance (i.e. adequate |S<sub>21</sub>|) of the amplifier. Acceptably high |S<sub>21</sub>| of the internal gain stages will ensure low amplifier input capacitance and hence low input referred noise current. Transimpedance sensitivity and bandwidth are then guaranteed by design and correlation with RF and DC die sort test results. In applications that require - 41 dBm sensitivity, a low capacitance (< 0.5pF) and high responsivity (> 0.95) photodiode must be used.

### Indirect Measurement of Optical Overload

Optical overload can be defined as the maximum optical power above, which the BER (bit error rate) increases beyond 1 error in 10<sup>10</sup> bits. The ATA01502D1C is 100% tested at die sort by a DC measurement, which has excellent correlation with a PRBS optical overload measurement. The measurement consists of sinking a negative current (see V<sub>OUT</sub> Vs I<sub>IN</sub> figure) from the TIA and determining the point of output voltage collapse. In addition, the input node virtual ground during “heavy AGC” is checked to verify that the linearity (i.e. pulse width distortion) of the amplifier has not been compromised. As a final test, a DC transfer curve is performed on every die at the wafer level to ensure excellent overload performance.

### Measurement of Input Referred Noise Current

The “Input Noise Current” is directly related to sensitivity. It can be defined as the output noise voltage (V<sub>OUT</sub>), with no input signal, (including a 100 MHz lowpass filter at the output of the TIA) divided by the AC transresistance.

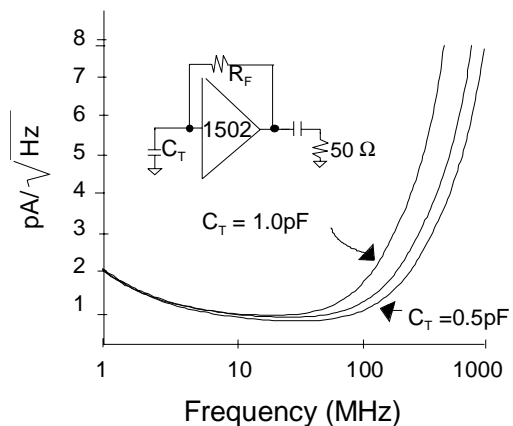

Figure 10: Input Referred Noise Spectral Density

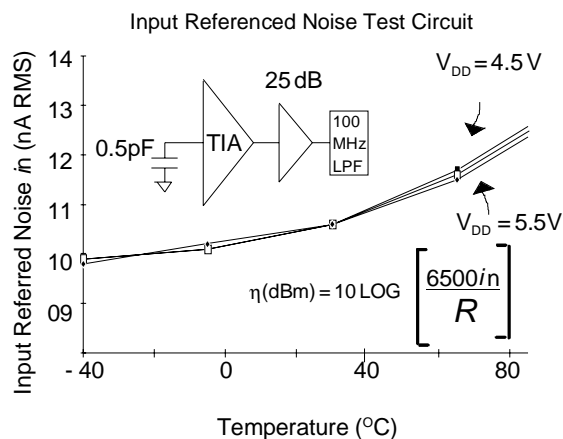
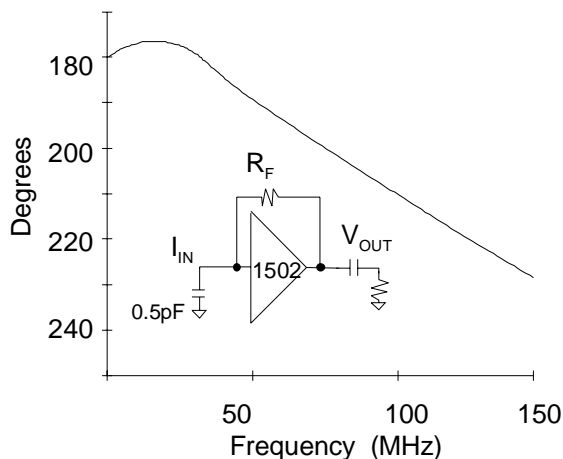

Figure 11: Input Referred Noise vs Temperature

Figure 12: Phase ( $I_{IN}$  to  $V_{OUT}$ )

### AGC Capacitor

It is important to select an external AGC capacitor of high quality and appropriate size. The ATA01502D1C has an on-chip 70 K  $\Omega$  resistor with a shunt 4.5-pF capacitor to ground. Without external capacitance, the chip will provide an AGC time constant of 315 nS. For the best performance in a typical 155 MB/s SONET receiver, a minimum AGC capacitor of 56pF is recommended. This will provide the minimum amount of protection against pattern sensitivity and pulse width distortion on repetitive data sequences during high average optical power conditions. Conservative design practices should be followed when selecting an AGC capacitor, since unit to unit variability of the internal time constant and various data conditions can lead to data errors if the chosen value is too small.

### Phase Response

At frequencies below the 3dB bandwidth of the device, the transimpedance phase response is characteristic of a single pole transfer function (as shown in the Phase Vs Frequency curve). The output impedance is essentially resistive up to 1000 MHz.

**ORDERING INFORMATION**

PART NUMBER	PACKAGE OPTION	PACKAGE DESCRIPTION
ATA01501D1C	D1C	Die



**ANADIGICS, Inc.**

141 Mount Bethel Road

Warren, New Jersey 07059, U.S.A

Tel: +1 (908) 668-5000

Fax: +1 (908) 668-5132

<http://www.anadigics.com>

[Mktg@anadigics.com](mailto:Mktg@anadigics.com)

**IMPORTANT NOTICE**

ANADIGICS, Inc. reserves the right to make changes to its products or to discontinue any product at any time without notice. The product specifications contained in Advanced Product Information sheets and Preliminary Data Sheets are subject to change prior to a product's formal introduction. Information in Data Sheets have been carefully checked and are assumed to be reliable; however, ANADIGICS assumes no responsibilities for inaccuracies. ANADIGICS strongly urges customers to verify that the information they are using is current before placing orders.

**WARNING**

ANADIGICS products are not intended for use in life support appliances, devices, or systems. Use of an ANADIGICS product in any such application without written consent is prohibited.



SUNSTAR 商斯达实业集团是集研发、生产、工程、销售、代理经销、技术咨询、信息服务等为一体的高科技企业，是专业高科技电子产品生产厂家，是具有 10 多年历史的专业电子元器件供应商，是中国最早和最大的仓储式连锁规模经营大型综合电子零部件代理分销商之一，是一家专业代理和分销世界各大品牌 IC 芯片和电子元器件的连锁经营综合性国际公司，专业经营进口、国产名厂名牌电子元件，型号、种类齐全。在香港、北京、深圳、上海、西安、成都等全国主要电子市场设有直属分公司和产品展示展销窗口门市部专卖店及代理分销商，已在全国范围内建成强大统一的供货和代理分销网络。我们专业代理经销、开发生产电子元器件、集成电路、传感器、微波光电元器件、工控机/DOC/DOM 电子盘、专用电路、单片机开发、MCU/DSP/ARM/FPGA 软件硬件、二极管、三极管、模块等，是您可靠的一站式现货配套供应商、方案提供商、部件功能模块开发配套商。商斯达实业公司拥有庞大的资料库，有数位毕业于著名高校——有中国电子工业摇篮之称的西安电子科技大学（西军电）并长期从事国防尖端科技研究的高级工程师为您精挑细选、量身订做各种高科技电子元器件，并解决各种技术问题。

微波光电部专业代理经销高频、微波、光纤、光电元器件、组件、部件、模块、整机；电磁兼容元器件、材料、设备；微波 CAD、EDA 软件、开发测试仿真工具；微波、光纤仪器仪表。欢迎国外高科技微波、光纤厂商将优秀产品介绍到中国、共同开拓市场。长期大量现货专业批发高频、微波、卫星、光纤、电视、CATV 器件：晶振、VCO、连接器、PIN 开关、变容二极管、开关二极管、低噪晶体管、功率电阻及电容、放大器、功率管、MMIC、混频器、耦合器、功分器、振荡器、合成器、衰减器、滤波器、隔离器、环行器、移相器、调制解调器；光电子器件和组件：红外发射管、红外接收管、光电开关、光敏管、发光二极管和发光二极管组件、半导体激光二极管和激光器组件、光电探测器和光接收组件、光发射接收模块、光纤激光器和光放大器、光调制器、光开关、DWDM 用光发射和接收器件、用户接入系统光收发器件与模块、光纤连接器、光纤跳线/尾纤、光衰减器、光纤适配器、光隔离器、光耦合器、光环行器、光复用器/转换器；无线收发芯片和模组、蓝牙芯片和模组。

更多产品请看本公司产品专用销售网站：

商斯达中国传感器科技信息网：<http://www.sensor-ic.com/>

商斯达工控安防网：<http://www.pc-ps.net/>

商斯达电子元器件网：<http://www.sunstare.com/>

商斯达微波光电产品网：[HTTP://www.rfoe.net/](http://www.rfoe.net/)

商斯达消费电子产品网：<http://www.icasic.com/>

商斯达实业科技产品网：<http://www.sunstars.cn/> 微波元器件销售热线：

地址：深圳市福田区福华路福庆街鸿图大厦 1602 室

电话：0755-82884100 83397033 83396822 83398585

传真：0755-83376182 (0) 13823648918 MSN: SUNS8888@hotmail.com

邮编：518033 E-mail:szss20@163.com QQ: 195847376

深圳赛格展销部：深圳华强北路赛格电子市场 2583 号 电话：0755-83665529 25059422

技术支持：0755-83394033 13501568376

欢迎索取免费详细资料、设计指南和光盘；产品凡多，未能尽录，欢迎来电查询。

北京分公司：北京海淀区知春路 132 号中发电子大厦 3097 号

TEL: 010-81159046 82615020 13501189838 FAX: 010-62543996

上海分公司：上海市北京东路 668 号上海赛格电子市场 D125 号

TEL: 021-28311762 56703037 13701955389 FAX: 021-56703037

西安分公司：西安高新开发区 20 所(中国电子科技集团导航技术研究所)

西安劳动南路 88 号电子商城二楼 D23 号

TEL: 029-81022619 13072977981 FAX:029-88789382