

5-TAP, HCMOS-INTERFACED FIXED DELAY LINE (SERIES DDU66C)

**data
delay
devices, inc.**



FEATURES

- Five equally spaced outputs
- Fits standard 14-pin DIP socket
- Low profile
- Auto-insertable
- Input & outputs fully CMOS interfaced & buffered
- 10 T²L fan-out capability

PACKAGES

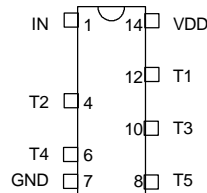

DDU66C-xx DIP
DDU66C-xxA2 Gull-Wing
DDU66C-xxB2 J-Lead
DDU66C-xxME7 Military DIP

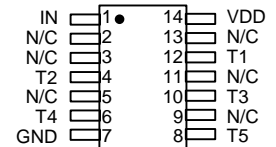

DDU66C-xxMD1 Com. SMD
DDU66C-xxMD4 Com. SMD
DDU66C-xxMD1 Mil. SMD
DDU66C-xxMD4 Mil. SMD

FUNCTIONAL DESCRIPTION

The DDU66C-series device is a 5-tap digitally buffered delay line. The signal input (IN) is reproduced at the outputs (T1-T5), shifted in time by an amount given by the device dash number. For dash numbers less than 40, the total delay of the line is measured from T1 to T5, with the nominal value given by the dash number. The nominal tap-to-tap delay increment is given by 1/4 of this number. The inherent delay from IN to T1 is nominally 8.0ns. For dash numbers greater than or equal to 40, the total delay of the line is measured from IN to T5, with the nominal value given by the dash number. The nominal tap-to-tap delay increment is given by 1/5 of this number.

PIN DESCRIPTIONS

IN Signal Input
T1-T5 Tap Outputs
VDD +5 Volts
GND Ground

SERIES SPECIFICATIONS

- **Minimum input pulse width:** 40% of total delay
- **Output rise time:** 8ns typical
- **Supply voltage:** 5VDC \pm 5%
- **Supply current:** I_{CCL} = 40 μ A typical
I_{CCH} = 10mA typical
- **Operating temperature:** 0° to 70° C
- **Temp. coefficient of total delay:** 300 PPM/°C

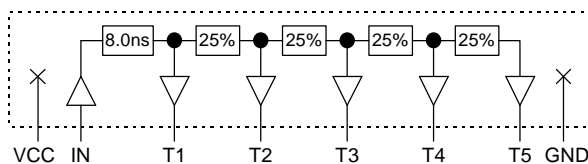

Functional diagram for dash numbers < 40

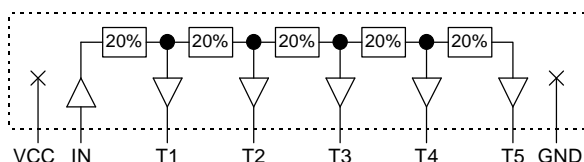

Functional diagram for dash numbers \geq 40

DASH NUMBER SPECIFICATIONS

Part Number	Total Delay (ns)	Delay Per Tap (ns)
DDU222C-10	10 \pm 2.0 *	2.5 \pm 1.0
DDU222C-20	20 \pm 2.0 *	5.0 \pm 2.0
DDU222C-50	50 \pm 3.0	10.0 \pm 3.0
DDU222C-60	60 \pm 3.0	12.0 \pm 3.0
DDU222C-75	75 \pm 4.0	15.0 \pm 3.0
DDU222C-100	100 \pm 5.0	20.0 \pm 3.0
DDU222C-125	125 \pm 6.5	25.0 \pm 3.0
DDU222C-150	150 \pm 7.5	30.0 \pm 3.0
DDU222C-175	175 \pm 8.0	35.0 \pm 4.0
DDU222C-200	200 \pm 10.0	40.0 \pm 4.0
DDU222C-250	250 \pm 12.5	50.0 \pm 5.0

* Total delay is referenced to first tap output
Input to first tap = 8.0ns \pm 2ns

NOTE: Any dash number between 10 and 250 not shown is also available.

©1997 Data Delay Devices

APPLICATION NOTES

HIGH FREQUENCY RESPONSE

The DDU66C tolerances are guaranteed for input pulse widths and periods greater than those specified in the test conditions. Although the device will function properly for pulse widths as small as 40% of the total delay and periods as small as 80% of the total delay (for a symmetric input), the delays may deviate from their values at low frequency. However, for a given input condition, the deviation will be repeatable from pulse to pulse. Contact technical support at Data

Delay Devices if your application requires device testing at a specific input condition.

POWER SUPPLY BYPASSING

The DDU66C relies on a stable power supply to produce repeatable delays within the stated tolerances. A 0.1uf capacitor from VDD to GND, located as close as possible to the VDD pin, is recommended. A wide VDD trace and a clean ground plane should be used.

DEVICE SPECIFICATIONS

TABLE 1: ABSOLUTE MAXIMUM RATINGS

PARAMETER	SYMBOL	MIN	MAX	UNITS	NOTES
DC Supply Voltage	V_{DD}	-0.3	7.0	V	
Input Pin Voltage	V_{IN}	-0.3	$V_{DD}+0.3$	V	
Storage Temperature	T_{STRG}	-55	150	C	
Lead Temperature	T_{LEAD}		300	C	10 sec

TABLE 2: DC ELECTRICAL CHARACTERISTICS

(0C to 70C, 4.75V to 5.25V)

PARAMETER	SYMBOL	MIN	TYP	MAX	UNITS	NOTES
High Level Output Voltage	V_{OH}	3.98	4.4		V	$V_{DD} = 5.0, I_{OH} = MAX$ $V_{IH} = MIN, V_{IL} = MAX$
Low Level Output Voltage	V_{OL}		0.15	0.26	V	$V_{DD} = 5.0, I_{OL} = MAX$ $V_{IH} = MIN, V_{IL} = MAX$
High Level Output Current	I_{OH}			-4.0	mA	
Low Level Output Current	I_{OL}			4.0	mA	
High Level Input Voltage	V_{IH}	3.15			V	
Low Level Input Voltage	V_{IL}			1.35	V	
Input Current	I_{IH}			0.10	μA	$V_{DD} = 5.0$

PACKAGE DIMENSIONS

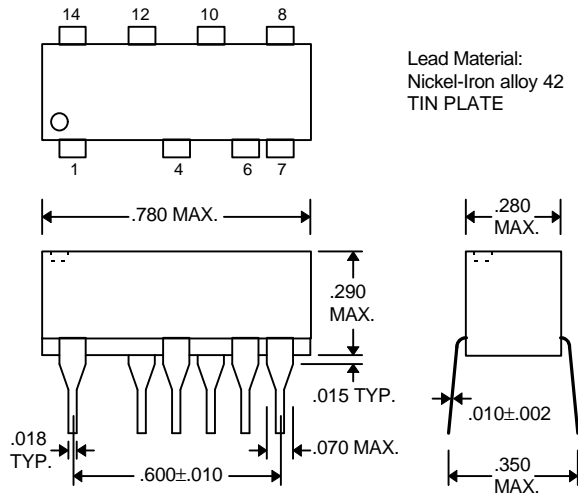

DDU66C-xx (Commercial)

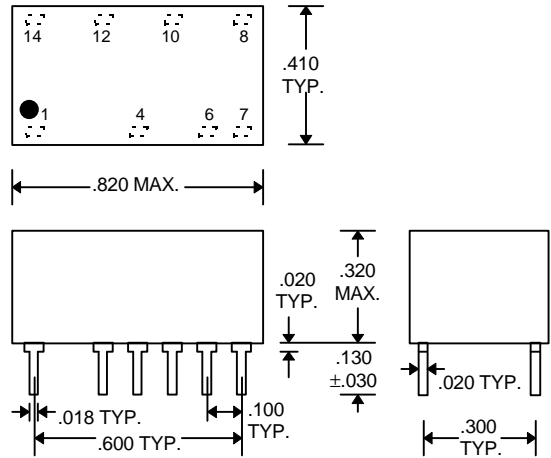

DDU66C-xxME7 (Military)

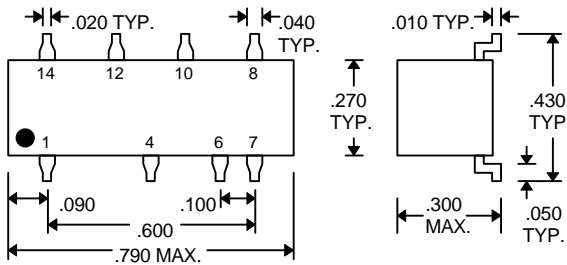

DDU66C-xxA2 (Commercial Gull-Wing)

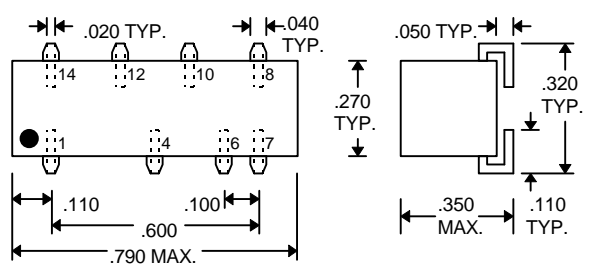

DDU66C-xxB2 (Commercial J-Lead)

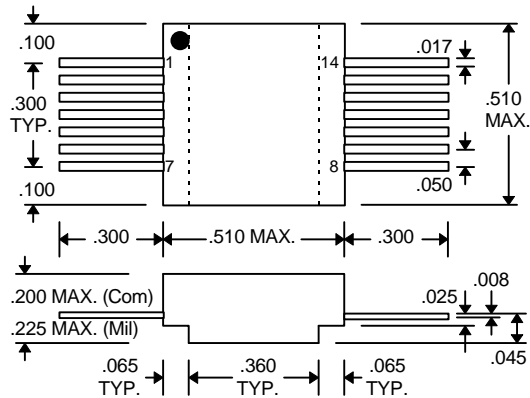

DDU66C-xxD1 (Commercial SMD)
DDU66C-xxD1 (Military SMD)

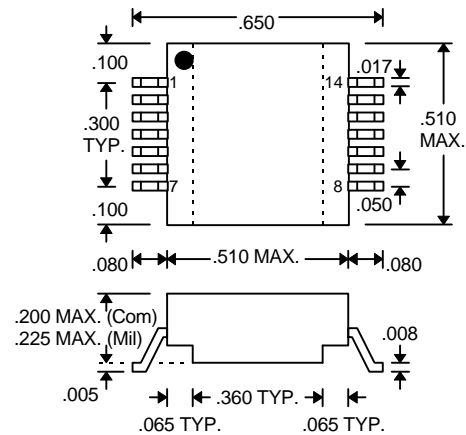

DDU66C-xxD4 (Commercial SMD)
DDU66C-xxD4 (Military SMD)

DELAY LINE AUTOMATED TESTING

TEST CONDITIONS

INPUT:

Ambient Temperature: $25^{\circ}\text{C} \pm 3^{\circ}\text{C}$
Supply Voltage (VDD): $5.0\text{V} \pm 0.1\text{V}$
Input Pulse: High = $5.0\text{V} \pm 0.1\text{V}$
 Low = $0.0\text{V} \pm 0.1\text{V}$
Source Impedance: 50Ω Max.
Rise/Fall Time: 5.0 ns Max. (measured between 0.5V and 4.5V)
Pulse Width: $\text{PW}_{\text{IN}} = 1.5 \times \text{Total Delay}$
Period: $\text{PER}_{\text{IN}} = 10 \times \text{Total Delay}$

OUTPUT:

Load: 1 FAST-TTL Gate
C_{load}: $5\text{pf} \pm 10\%$
Threshold: 2.5V (Rising & Falling)

NOTE: The above conditions are for test only and do not in any way restrict the operation of the device.

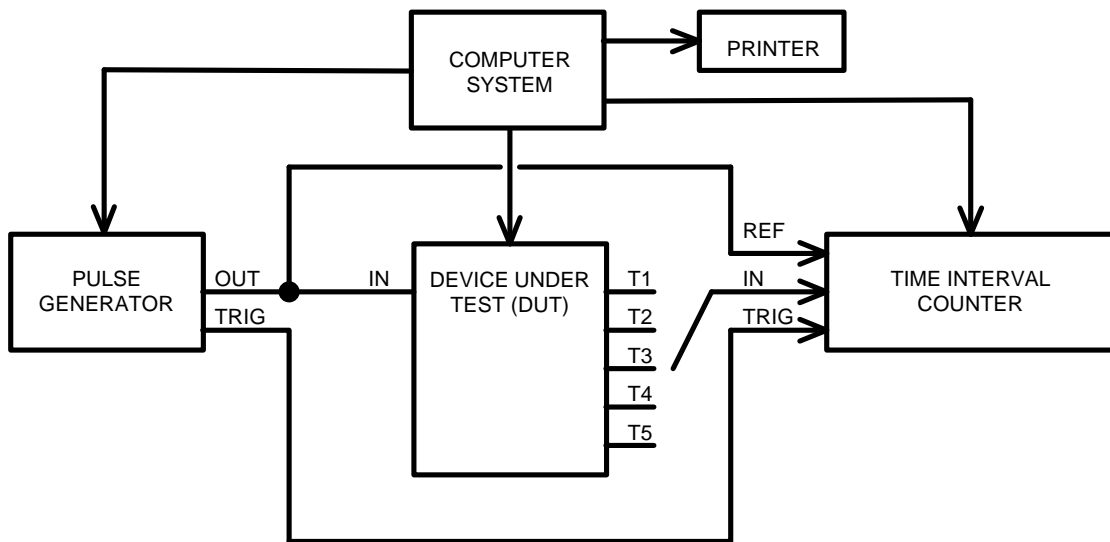

Test Setup

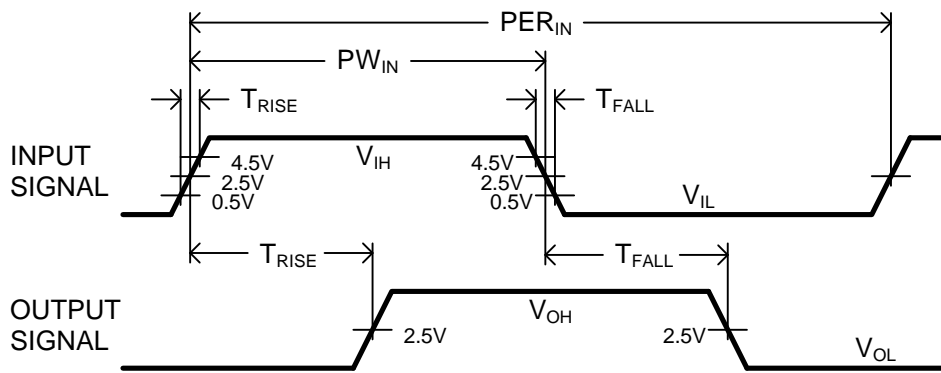

Timing Diagram For Testing

SUNSTAR 商斯达实业集团是集研发、生产、工程、销售、代理经销、技术咨询、信息服务等为一体的高科技企业，是专业高科技电子产品生产厂家，是具有 10 多年历史的专业电子元器件供应商，是中国最早和最大的仓储式连锁规模经营大型综合电子零部件代理分销商之一，是一家专业代理和分销世界各大品牌 IC 芯片和电子元器件的连锁经营综合性国际公司，专业经营进口、国产名厂名牌电子元件，型号、种类齐全。在香港、北京、深圳、上海、西安、成都等全国主要电子市场设有直属分公司和产品展示展销窗口门市部专卖店及代理分销商，已在全国范围内建成强大统一的供货和代理分销网络。我们专业代理经销、开发生产电子元器件、集成电路、传感器、微波光电元器件、工控机/DOC/DOM 电子盘、专用电路、单片机开发、MCU/DSP/ARM/FPGA 软件硬件、二极管、三极管、模块等，是您可靠的一站式现货配套供应商、方案提供商、部件功能模块开发配套商。商斯达实业公司拥有庞大的资料库，有数位毕业于著名高校——有中国电子工业摇篮之称的西安电子科技大学（西军电）并长期从事国防尖端科技研究的高级工程师为您精挑细选、量身订做各种高科技电子元器件，并解决各种技术问题。

微波光电部专业代理经销高频、微波、光纤、光电元器件、组件、部件、模块、整机；电磁兼容元器件、材料、设备；微波 CAD、EDA 软件、开发测试仿真工具；微波、光纤仪器仪表。欢迎国外高科技微波、光纤厂商将优秀产品介绍到中国、共同开拓市场。长期大量现货专业批发高频、微波、卫星、光纤、电视、CATV 器件：晶振、VCO、连接器、PIN 开关、变容二极管、开关二极管、低噪晶体管、功率电阻及电容、放大器、功率管、MMIC、混频器、耦合器、功分器、振荡器、合成器、衰减器、滤波器、隔离器、环行器、移相器、调制解调器；光电子器件和组件：红外发射管、红外接收管、光电开关、光敏管、发光二极管和发光二极管组件、半导体激光二极管和激光器组件、光电探测器和光接收组件、光发射接收模块、光纤激光器和光放大器、光调制器、光开关、DWDM 用光发射和接收器件、用户接入系统光收发器件与模块、光纤连接器、光纤跳线/尾纤、光衰减器、光纤适配器、光隔离器、光耦合器、光环行器、光复用器/转换器；无线收发芯片和模组、蓝牙芯片和模组。

更多产品请看本公司产品专用销售网站：

商斯达中国传感器科技信息网：<http://www.sensor-ic.com/>

商斯达工控安防网：<http://www.pc-ps.net/>

商斯达电子元器件网：<http://www.sunstare.com/>

商斯达微波光电产品网：[HTTP://www.rfoe.net/](http://www.rfoe.net/)

商斯达消费电子产品网：<http://www.icasic.com/>

商斯达实业科技产品网：<http://www.sunstars.cn/> 微波元器件销售热线：

地址：深圳市福田区福华路福庆街鸿图大厦 1602 室

电话：0755-82884100 83397033 83396822 83398585

传真：0755-83376182 (0) 13823648918 MSN: SUNS8888@hotmail.com

邮编：518033 E-mail:szss20@163.com QQ: 195847376

深圳赛格展销部：深圳华强北路赛格电子市场 2583 号 电话：0755-83665529 25059422

技术支持：0755-83394033 13501568376

欢迎索取免费详细资料、设计指南和光盘；产品凡多，未能尽录，欢迎来电查询。

北京分公司：北京海淀区知春路 132 号中发电子大厦 3097 号

TEL: 010-81159046 82615020 13501189838 FAX: 010-62543996

上海分公司：上海市北京东路 668 号上海赛格电子市场 D125 号

TEL: 021-28311762 56703037 13701955389 FAX: 021-56703037

西安分公司：西安高新开发区 20 所(中国电子科技集团导航技术研究所)

西安劳动南路 88 号电子商城二楼 D23 号

TEL: 029-81022619 13072977981 FAX:029-88789382