

# ACPL-4800

## High CMR Intelligent Power Module and Gate Drive Interface Optocoupler



### Datasheet

#### Description

The ACPL-4800 fast speed optocoupler contains a GaAsP LED and photo detector with built-in Schmitt trigger to provide logic-compatible waveforms, eliminating the need for additional wave shaping. The totem pole output eliminates the need for a pull up resistor and allows for direct drive Intelligent Power Module or gate drive.

#### Functional Diagram

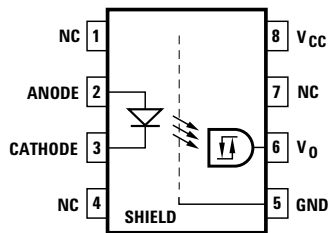

TRUTH TABLE  
(POSITIVE LOGIC)

LED	V <sub>O</sub>
ON	HIGH
OFF	LOW

Note: The connection of a 0.1  $\mu$ F bypass capacitor between pins 5 & 8 is recommended.

#### Features

- Performance Specified for Fast IPM Applications over Industrial Temperature Range: -40°C to 100°C
- Wide Operating V<sub>CC</sub> Range: 4.5 to 20 Volts
- Typical Propagation Delays 150 ns
- Minimized Pulse Width Distortion  
PWD = 250 ns
- Propagation Delay Difference  
Min. -100 ns, Max. 250 ns
- 30 kV/ $\mu$ s Minimum Common Mode Transient Immunity at V<sub>CM</sub> = 1000 V
- Hysteresis
- Totem Pole Output (No Pull-up Resistor Required)
- Safety Approval:  
Pending for UL 1577, 3750 Vrms / 1 minute  
Pending for CSA File CA88324, Notice #5  
Pending for IEC/EN/DIN EN 60747-5-2, V<sub>IORM</sub> = 630 Vpeak

#### Applications

- IPM Interface Isolation
- Isolated IGBT/MOSFET Gate Drive
- AC and Brushless DC Servo Motor Drives
- Low Power Inverters
- General Digital Isolation

### Ordering Information

Specify Part Number followed by Option Number (if desired).

Example:

ACPL-4800-XXX

- 060 = IEC/EN/DIN EN 60747-5-2 Option
- 300 = Gull Wing Lead Option
- 500 = Tape and Reel Packaging Option
- XXXE = Lead-Free Option

Option data sheets are available. Contact Avago sales representative or authorized distributor for information.

### Schematic

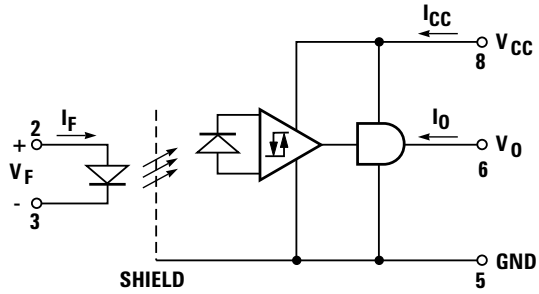

### Package Outline Drawings

#### DIP-8 Package

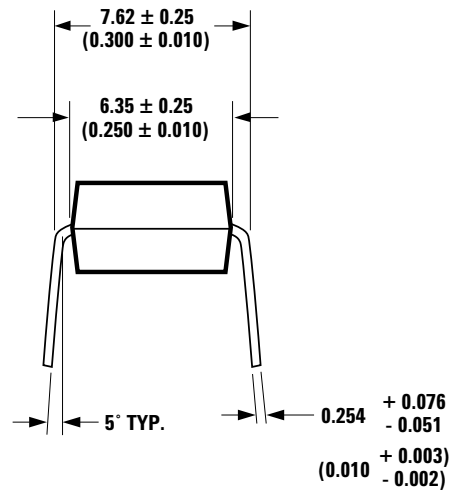
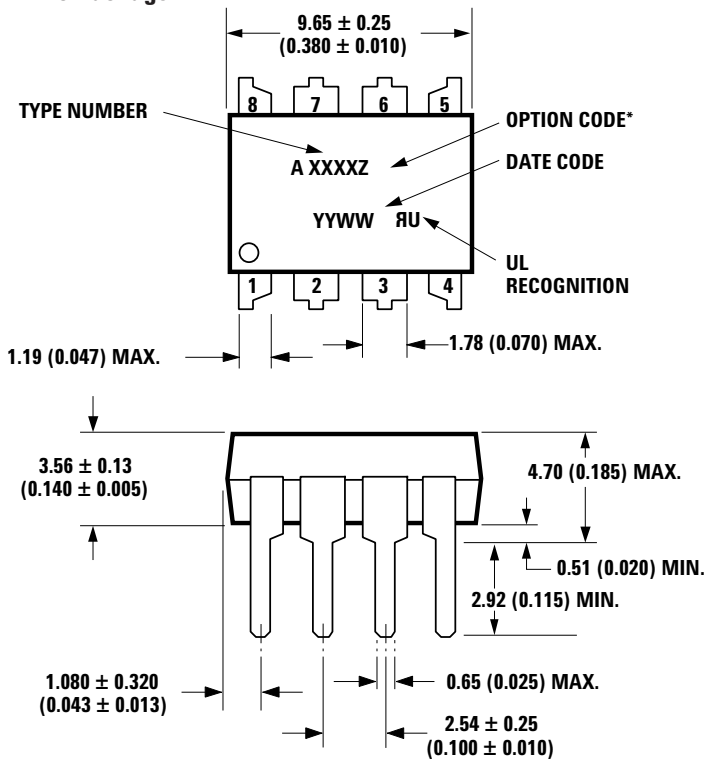

DIMENSIONS IN MILLIMETERS AND (INCHES).  
 \* MARKING CODE LETTER FOR OPTION NUMBERS  
 "V" = OPTION 060  
 OPTION NUMBERS 300 AND 500 NOT MARKED.

**DIP-8 Package with Gull Wing Surface Mount Option 300**

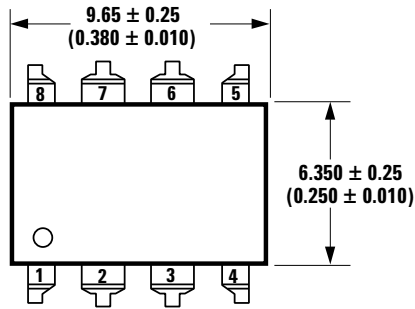

**LAND PATTERN RECOMMENDATION**

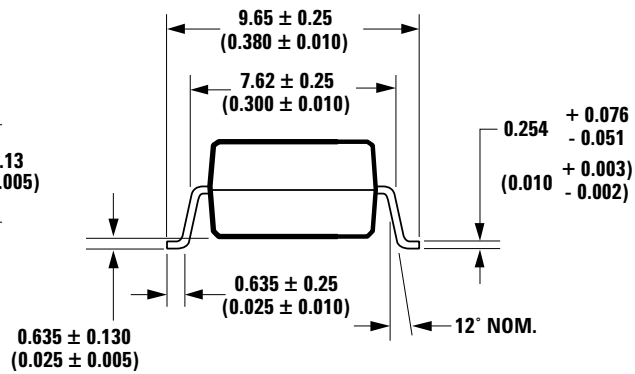
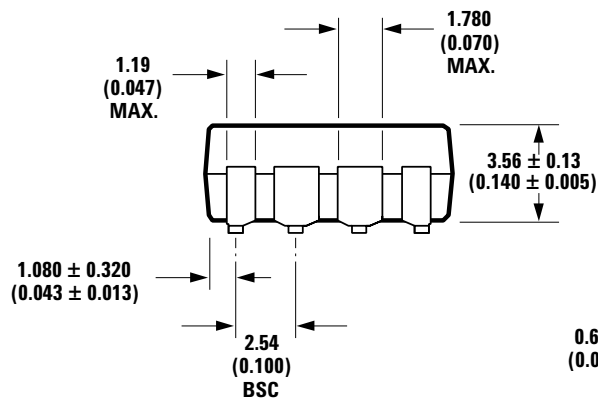
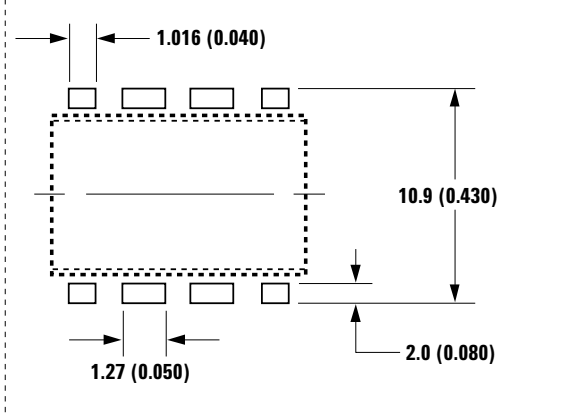

**DIMENSIONS IN MILLIMETERS (INCHES).**  
**LEAD COPLANARITY = 0.10 mm (0.004 INCHES).**

**NOTE: FLOATING LEAD PROTRUSION IS 0.25 mm (10 mils) MAX.**

**Solder Reflow Temperature Profile (Gull Wing Surface Mount Option 300 Parts)**

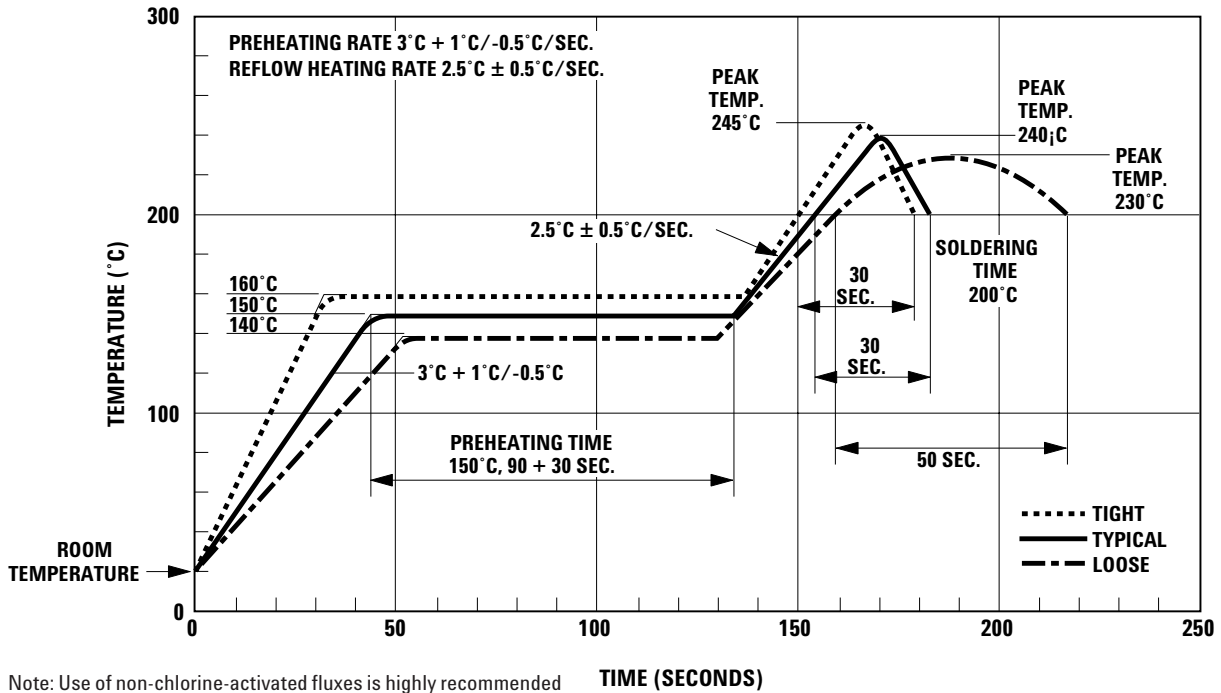

Note: Use of non-chlorine-activated fluxes is highly recommended

**Recommended Pb-Free IR Profile**

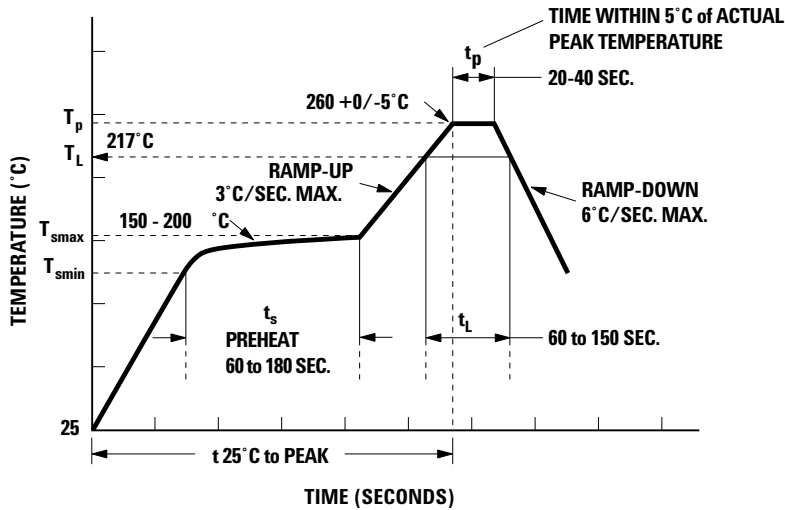

NOTES:  
 THE TIME FROM 25 C to PEAK TEMPERATURE = 8 MINUTES MAX.  
 $T_{smax} = 200^{\circ}\text{C}$ ,  $T_{smin} = 150^{\circ}\text{C}$

**Table 2. Insulation and Safety Related Specifications**

Parameter	Symbol	8-Pin DIP	Unit	Conditions
Minimum External Air Gap (External Clearance)	L(101)	7.1	mm	Measured from input terminals to output terminals, shortest distance through air.
Minimum External Tracking (External Creepage)	L(102)	7.4	mm	Measured from input terminals to output terminals, shortest distance path along body.
Minimum Internal Plastic Gap (Internal Clearance)		0.08		Through insulation distance, conductor to conductor, usually the direct distance between the photo emitter and photo detector inside the optocoupler cavity.
Minimum Internal Tracking (Internal Creepage)		NA	mm	Measured from input terminals to output terminals, along internal cavity.
Tracking Resistance (Comparative Tracking Index)	CTI	200	mm	DIN IEC 112/VDE 0303 Part 1
Isolation Group		IIIa		Material Group (DIN VDE 0110, 1/89, Table 1)

Option 300 - surface mount classification is Class A in accordance with CECC 00802.

**Table 3. IEC/EN/DIN EN 60747-5-2 Insulation Characteristics (Option 060)**

Description	Symbol	Characteristic	Unit
Installation classification per DIN VDE 0110/1.89, Table 1			
for rated mains voltage $\leq 300 V_{rms}$		I-IV	
for rated mains voltage $\leq 450 V_{rms}$		I-III	
Climatic Classification		55/85/21	
Pollution Degree (DIN VDE 0110/1.89)		2	
Maximum Working Insulation Voltage	$V_{IORM}$	630	$V_{peak}$
Input to Output Test Voltage, Method a* $V_{IORM} \times 1.875 = V_{PR}$ , 100% Production Test with $t_m = 1$ sec, Partial discharge $< 5$ pC	$V_{PR}$	1181	$V_{peak}$
Input to Output Test Voltage, Method a* $V_{IORM} \times 1.5 = V_{PR}$ , Type and Sample Test, $t_m = 60$ sec, Partial discharge $< 5$ pC	$V_{PR}$	945	$V_{peak}$
Highest Allowable Over-voltage (Transient Over-voltage $t_{ini} = 10$ sec)	$V_{IOTM}$	6000	$V_{peak}$
Safety-limiting values - maximum values allowed in the event of a failure.			
Case Temperature	$T_S$	175	$^{\circ}C$
Input Current	$I_{S, INPUT}$	230	mA
Output Power (refer to Thermal Derating Curve)	$P_{S, OUTPUT}$	600	mW
Insulation Resistance at $T_S$ , $V_{IO} = 500$ V	$R_S$	$>10^9$	$\Omega$

\* Refer to the optocoupler section of the Isolation and Control Components Designer's Catalog, under Product Safety Regulations section, (IEC/EN/DIN EN 60747-5-2) for a detailed description of Method a and Method b partial discharge test profiles.

Note:

Isolation characteristics are guaranteed only within the safety maximum ratings which must be ensured by protective circuits in application.

**Thermal Derating Curve**

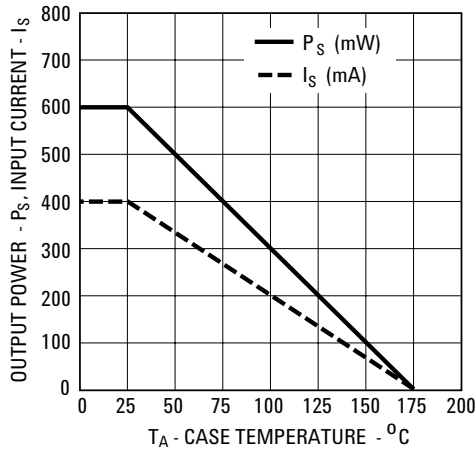

**Table 4. Absolute Maximum Rating**

Parameter	Symbol	Min.	Max.	Units	Note
Storage Temperature	T <sub>S</sub>	-55	125	°C	
Operating Temperature	T <sub>A</sub>	-40	100	°C	
Average Forward Input Current	I <sub>F(AVG)</sub>		10	mA	
Peak Transient Input Current ( ≤1 μs Pulse Width, 300 pps) ( ≤200 μs Pulse Width, < 1% Duty Cycle)	I <sub>F(TRAN)</sub>		1.0 40	A mA	
Reverse Input Voltage	V <sub>R</sub>		5	V	
Average Output Current	I <sub>O</sub>		25	mA	
Supply Voltage	V <sub>CC</sub>	0	25	V	
Output Voltage	V <sub>O</sub>	-0.5	25	V	
Total Package Power Dissipation	P <sub>T</sub>		210	mW	1
Lead Solder Temperature (Through Hole Parts Only)		260 °C for 10 sec., 1.6 mm below seating plane			
Solder Reflow Temperature Profile (Surface Mount Parts Only)		See Package Outline Drawings section			

**Table 5. Recommended Operating Conditions**

Parameter	Symbol	Min.	Max.	Units
Power Supply Voltage	V <sub>CC</sub>	4.5	20	V
Forward Input Current (ON)	I <sub>F(ON)</sub>	6	10	mA
Forward Input Voltage (OFF)	V <sub>F(OFF)</sub>	-	0.8	V
Operating Temperature	T <sub>A</sub>	-40	100	C

**Table 6. Electrical Specification**-40°C ≤ T<sub>A</sub> ≤ 100°C, 4.5V ≤ V<sub>CC</sub> ≤ 20V, 6mA ≤ I<sub>F(ON)</sub> ≤ 10 mA, 0V ≤ V<sub>F(OFF)</sub> ≤ 0.8 V, unless otherwise specified.All Typical at T<sub>A</sub> = 25°C. See Note 7.

Parameter	Sym.	Min.	Typ.	Max.	Units	Test Conditions	Fig.	Note
Logic Low Output Voltage	V <sub>OL</sub>			0.5	V	I <sub>OL</sub> = 6.4 mA	1,3	
Logic High Output Voltage	V <sub>OH</sub>	2.4	V <sub>CC</sub> - 1.1V		V	I <sub>OH</sub> = -2.6 mA	2,3,7	
		2.7				I <sub>OH</sub> = -0.4 mA		
Output Leakage Current (V <sub>OUT</sub> = V <sub>CC</sub> +0.5V)	I <sub>OHH</sub>			100	μA	V <sub>CC</sub> = 5 V	I <sub>F</sub> = 10mA	
				500		V <sub>CC</sub> = 20 V		
Logic Low Supply Current	I <sub>CCL</sub>		1.9	3.0	mA	V <sub>CC</sub> = 5.5 V	V <sub>F</sub> = 0 V	
			2.0	3.0		V <sub>CC</sub> = 20 V		I <sub>0</sub> = Open
Logic High Supply Current	I <sub>CCH</sub>		1.5	2.5	mA	V <sub>CC</sub> = 5.5 V	I <sub>F</sub> = 10 mA	
			1.6	2.5		V <sub>CC</sub> = 20 V		I <sub>0</sub> = Open
Logic Low Short Circuit Output Current	I <sub>OSL</sub>	25			mA	V <sub>0</sub> = V <sub>CC</sub> = 5.5 V	V <sub>F</sub> =0V	2
		50				V <sub>0</sub> = V <sub>CC</sub> = 20 V		
Logic High Short Circuit Output Current	I <sub>OSH</sub>			-25	mA	V <sub>CC</sub> = 5.5 V	I <sub>F</sub> =6mA	2
				-50		V <sub>CC</sub> = 20 V		
Input Forward Voltage	V <sub>F</sub>		1.5	1.7	V	T <sub>A</sub> = 25 C	I <sub>F</sub> =6mA	4
				1.85				
Input Reverse Breakdown Voltage	BV <sub>R</sub>	5			V	I <sub>R</sub> = 10 μA		
Input Diode Temperature Coefficient	DV <sub>F</sub> DT <sub>A</sub>		-1.7		mV/°C	I <sub>F</sub> = 6 mA		
Input Capacitance	C <sub>IN</sub>		60		pF	f = 1 MHz, V <sub>F</sub> = 0 V		3

**Table 7. Switching Specifications (AC)**

-40°C ≤ T<sub>A</sub> ≤ 100°C, 4.5V ≤ V<sub>CC</sub> ≤ 20V, 6mA ≤ I<sub>F(ON)</sub> ≤ 10 mA, 0V ≤ V<sub>F(OFF)</sub> ≤ 0.8V.

All Typical at T<sub>A</sub> = 25°C, I<sub>F(ON)</sub> = 6 mA unless otherwise specified.

Parameter	Sym.	Min.	Typ.	Max.	Units	Test Conditions	Fig.	Note
Propagation Delay Time to Logic Low Output Level	t <sub>PHL</sub>		150	350	ns	With Peaking Capacitor	5,6	5
Propagation Delay Time to Logic High Output Level	t <sub>PLH</sub>		110	350	ns	With Peaking Capacitor	5,6	5
Pulse Width Distortion	PWD			250	ns	t <sub>PHL</sub> - t <sub>PLH</sub>		8
Propagation Delay Difference Between Any 2 Parts	PDD	-100		250	ns			10
Output Rise Time (10-90%)	t <sub>r</sub>		16		ns		5,8	
Output Fall Time (90-10%)	t <sub>f</sub>		20		ns		5,8	
Logic High Common Mode Transient Immunity	CM <sub>H</sub>	-30000			V/μs	V <sub>CM</sub>   = 1000 V, I <sub>F</sub> = 6.0 mA, V <sub>CC</sub> = 5 V, T <sub>A</sub> = 25 C	9	6
Logic Low Common Mode Transient Immunity	CM <sub>L</sub>	30000			V/μs	V <sub>CM</sub>   = 1000 V, V <sub>F</sub> = 0 V, V <sub>CC</sub> = 5 V, T <sub>A</sub> = 25 C	9	6

**Table 8. Package Characteristics**

Parameter	Sym.	Min.	Typ.	Max.	Units	Test Conditions	Fig.	Note
Input-Output Momentary Withstand Voltage*	V <sub>ISO</sub>	3750			Vrms	RH < 50%, t = 1 min. T <sub>A</sub> = 25°C		4,7
Input-Output Resistance	R <sub>I-O</sub>		10 <sup>12</sup>		Ω	V <sub>I-O</sub> = 500 Vdc		4
Input-Output Capacitance	C <sub>I-O</sub>		0.6		pF	f = 1 MHz, V <sub>I-O</sub> = 0 Vdc		4

**Notes:**

- Derate total package power dissipation, P<sub>T</sub>, linearly above 70°C free-air temperature at a rate of 4.5 mW/°C.
- Duration of output short circuit time should not exceed 10 ms.
- Input capacitance is measured between pin 2 and pin 3.
- Device considered a two-terminal device: pins 1, 2, 3, and 4 shorted together and pins 5, 6, 7, and 8 shorted together.
- The t<sub>PLH</sub> propagation delay is measured from the 50% point on the leading edge of the input pulse to the 1.3 V point on the leading edge of the output pulse. The t<sub>PHL</sub> propagation delay is measured from the 50% point on the trailing edge of the input pulse to the 1.3 V point on the trailing edge of the output pulse.
- CMH is the maximum slew rate of the common mode voltage that can be sustained with the output voltage in the logic high state, V<sub>O</sub> > 2.0 V. CML is the maximum slew rate of the common mode voltage that can be sustained with the output voltage in the logic low state, V<sub>O</sub> < 0.8 V.
- In accordance with UL 1577, each optocoupler is proof tested by applying an insulation test voltage <sup>3</sup> 4200 V rms for one second (leakage detection current limit, I<sub>I-O</sub> ≤ 5 mA). This test is performed before the 100% production test for partial discharge (Method b) shown in the IEC/EN/DIN EN 60747-5-2 Insulation Characteristics Table, if applicable.
- Pulse Width Distortion (PWD) is defined as |t<sub>PHL</sub> - t<sub>PLH</sub>| for any given device.
- Use of a 0.1 μF bypass capacitor connected between pins 5 and 8 is recommended.
- The difference between t<sub>PLH</sub> and t<sub>PHL</sub> between any two devices under the same test condition.



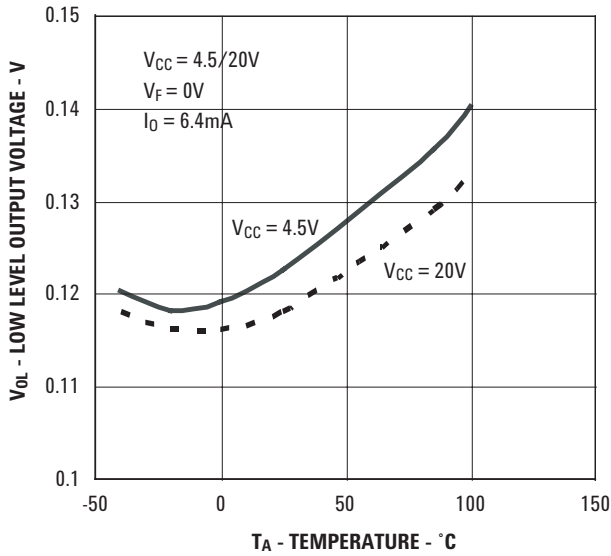

Figure 1. Typical Logic Low Output Voltage vs. Temperature

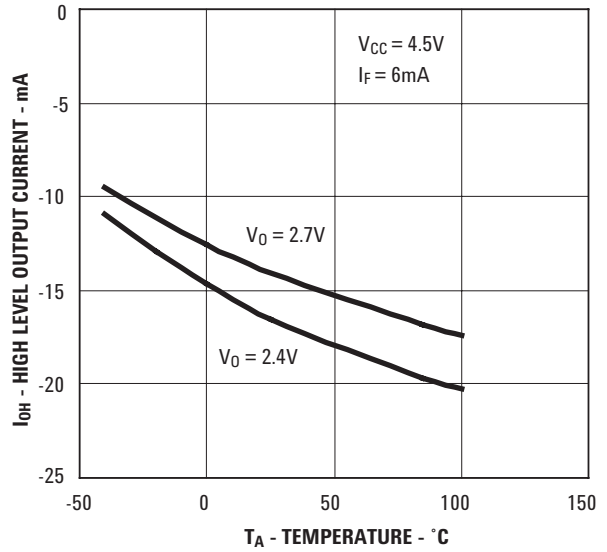

Figure 2. Typical Logic High Output Current vs. Temperature

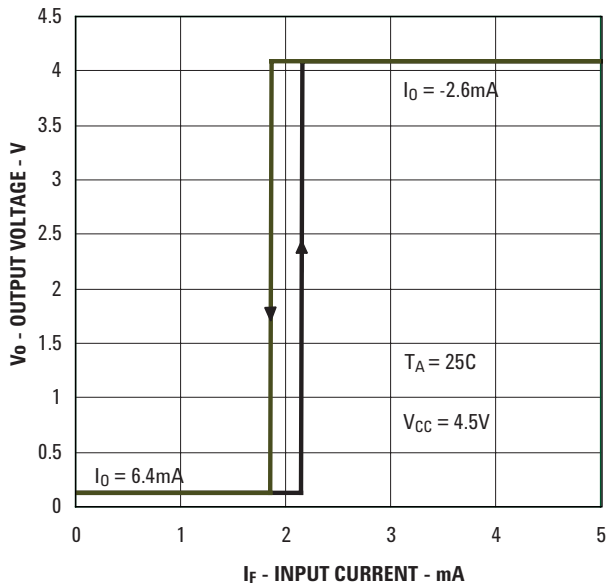

Figure 3. Typical Output Voltage vs. Forward Input Current

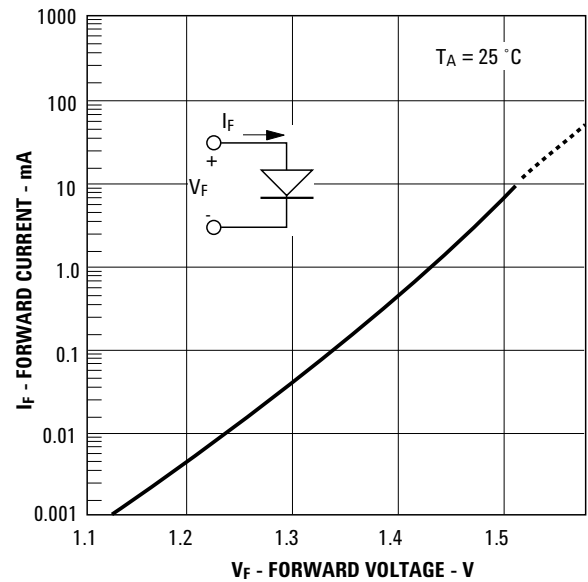

Figure 4. Typical Input Diode Forward Characteristic

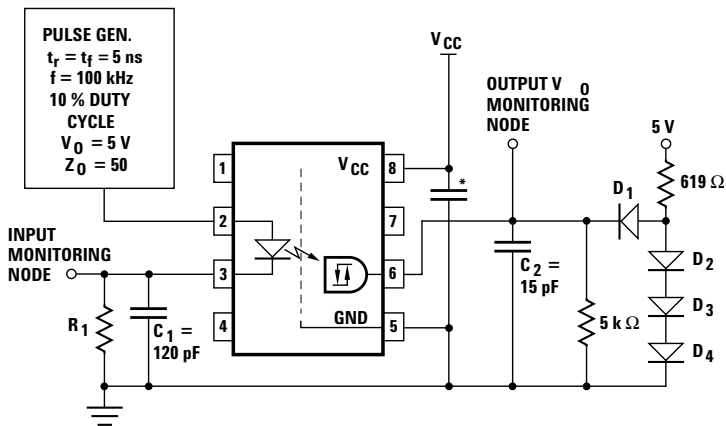
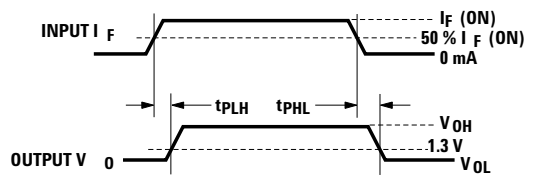

Figure 5. Circuit for  $t_{PLH}$ ,  $t_{PHL}$ ,  $t_r$ ,  $t_f$

THE PROBE AND JIG CAPACITANCES ARE INCLUDED IN C1 AND C2.

$R_1$	1.10 k $\Omega$	681 $\Omega$	330 $\Omega$
$I_F$ (ON)	3 mA	5 mA	10 mA

ALL DIODES ARE 1N916 OR 1N3064.



\* 0.1  $\mu$ F BYPASS  $\bar{N}$  SEE NOTE 9.

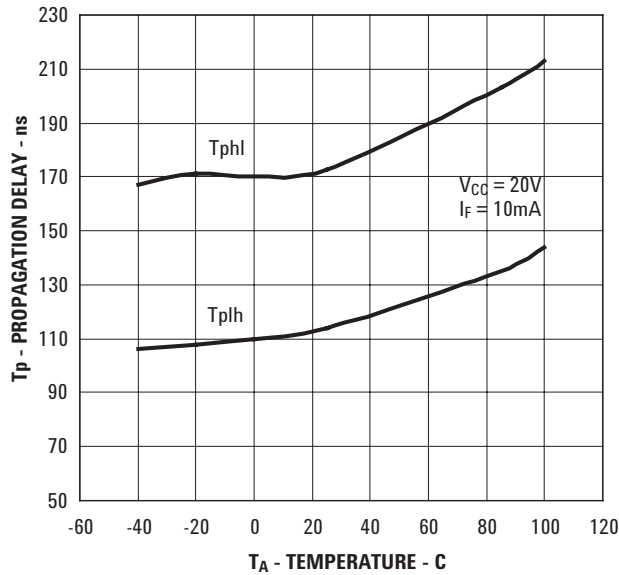

Figure 6. Typical Propagation Delays vs. Temperature.

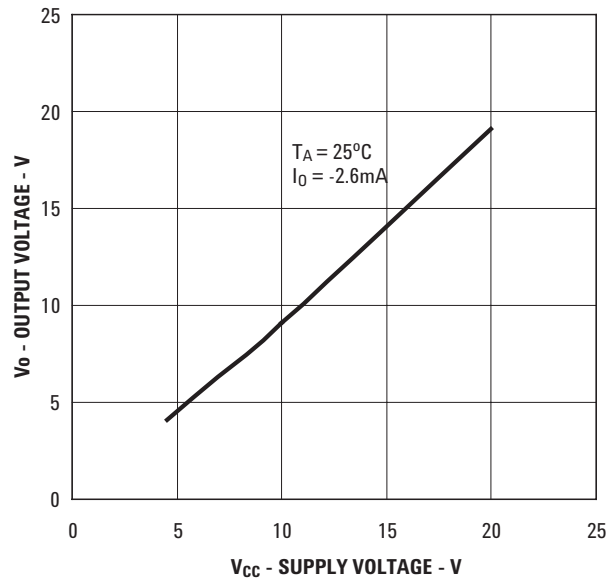

Figure 7. Typical Logic High Output Voltage vs. Supply Voltage

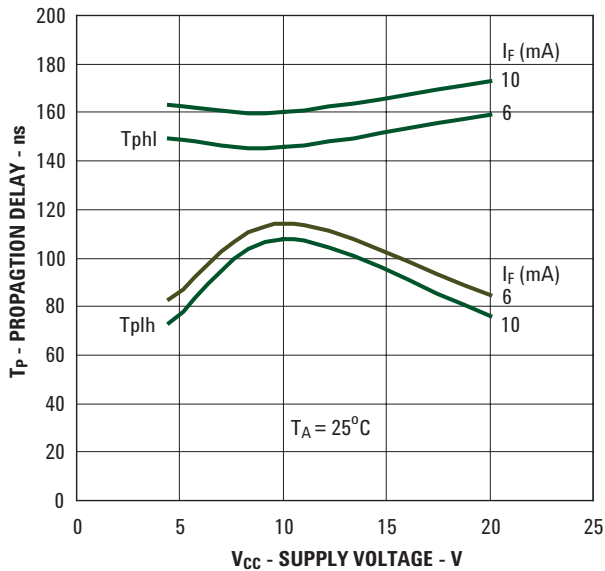

Figure 8. Typical Propagation Delays vs. Supply Voltage

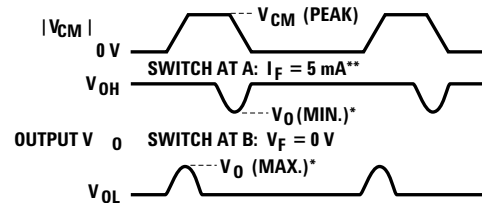
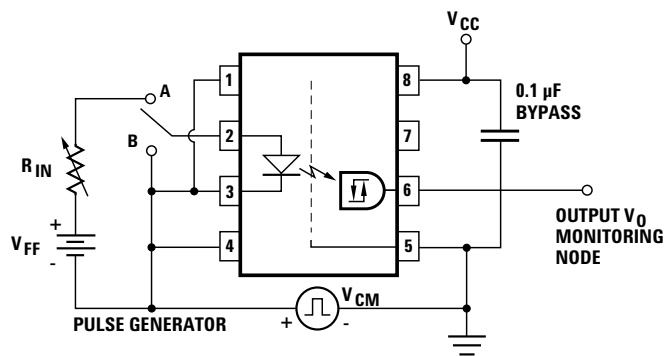

Figure 9. Test Circuit for Common Mode Transient Immunity and Typical Waveforms

For product information and a complete list of distributors, please go to our web site: [www.avagotech.com](http://www.avagotech.com)

Avago, Avago Technologies, and the A logo are trademarks of Avago Technologies, Pte. in the United States and other countries.  
Data subject to change. Copyright © 2006 Avago Technologies Pte. All rights reserved. Obsoletes 5989-4496EN  
5989-4685EN - January 9, 2006



SUNSTAR 商斯达实业集团是集研发、生产、工程、销售、代理经销、技术咨询、信息服务等为一体的高科技企业，是专业高科技电子产品生产厂家，是具有 10 多年历史的专业电子元器件供应商，是中国最早和最大的仓储式连锁规模经营大型综合电子零部件代理分销商之一，是一家专业代理和分销世界各大品牌 IC 芯片和电子元器件的连锁经营综合性国际公司，专业经营进口、国产名厂名牌电子元件，型号、种类齐全。在香港、北京、深圳、上海、西安、成都等全国主要电子市场设有直属分公司和产品展示展销窗口门市部专卖店及代理分销商，已在全国范围内建成强大统一的供货和代理分销网络。我们专业代理经销、开发生产电子元器件、集成电路、传感器、微波光电元器件、工控机/DOC/DOM 电子盘、专用电路、单片机开发、MCU/DSP/ARM/FPGA 软件硬件、二极管、三极管、模块等，是您可靠的一站式现货配套供应商、方案提供商、部件功能模块开发配套商。商斯达实业公司拥有庞大的资料库，有数位毕业于著名高校——有中国电子工业摇篮之称的西安电子科技大学（西军电）并长期从事国防尖端科技研究的高级工程师为您精挑细选、量身订做各种高科技电子元器件，并解决各种技术问题。

微波光电部专业代理经销高频、微波、光纤、光电元器件、组件、部件、模块、整机；电磁兼容元器件、材料、设备；微波 CAD、EDA 软件、开发测试仿真工具；微波、光纤仪器仪表。欢迎国外高科技微波、光纤厂商将优秀产品介绍到中国、共同开拓市场。长期大量现货专业批发高频、微波、卫星、光纤、电视、CATV 器件：晶振、VCO、连接器、PIN 开关、变容二极管、开关二极管、低噪晶体管、功率电阻及电容、放大器、功率管、MMIC、混频器、耦合器、功分器、振荡器、合成器、衰减器、滤波器、隔离器、环行器、移相器、调制解调器；光电子器件和组件：红外发射管、红外接收管、光电开关、光敏管、发光二极管和发光二极管组件、半导体激光二极管和激光器组件、光电探测器和光接收组件、光发射接收模块、光纤激光器和光放大器、光调制器、光开关、DWDM 用光发射和接收器件、用户接入系统光收发器件与模块、光纤连接器、光纤跳线/尾纤、光衰减器、光纤适配器、光隔离器、光耦合器、光环行器、光复用器/转换器；无线收发芯片和模组、蓝牙芯片和模组。

更多产品请看本公司产品专用销售网站：

商斯达微波光电产品网：[HTTP://www.rfoe.net/](http://www.rfoe.net/)

商斯达中国传感器科技信息网：<http://www.sensor-ic.com/>

商斯达工控安防网：<http://www.pc-ps.net/>

商斯达电子元器件网：<http://www.sunstare.com/>

商斯达消费电子产品网：<http://www.icasic.com/>

商斯达实业科技产品网：<http://www.sunstars.cn/> 射频微波光电元器件销售热线：

地址：深圳市福田区福华路福庆街鸿图大厦 1602 室

电话：0755-83396822 83397033 83398585 82884100

传真：0755-83376182 (0) 13823648918 MSN: SUNS8888@hotmail.com

邮编：518033 E-mail:szss20@163.com QQ: 195847376

深圳赛格展销部：深圳华强北路赛格电子市场 2583 号 电话：0755-83665529 25059422

技术支持：0755-83394033 13501568376

欢迎索取免费详细资料、设计指南和光盘；产品凡多，未能尽录，欢迎来电查询。

北京分公司：北京海淀区知春路 132 号中发电子大厦 3097 号

TEL: 010-81159046 82615020 13501189838 FAX: 010-62543996

上海分公司：上海市北京东路 668 号上海赛格电子市场 D125 号

TEL: 021-28311762 56703037 13701955389 FAX: 021-56703037

西安分公司：西安高新开发区 20 所(中国电子科技集团导航技术研究所)

西安劳动南路 88 号电子商城二楼 D23 号

TEL: 029-81022619 13072977981 FAX:029-88789382