



# Low On-Resistance Solid State Relays

## Application Note 1046

### Introduction

The on-resistance is an important specification for a solid state relay that uses MOSFETs at its output. In general, a lower on-resistance rating will allow a higher contact current rating. The HSSR-8060 and HSSR-8400 are single-pole, normally open, solid state relays (SSR) with very low on-resistances. Each SSR consists of a high-voltage circuit, optically coupled with a light-emitting diode (LED). When a control current flows through the input terminals of the SSR, the LED emits light onto a photodiode array, illustrated in Figure 1, generates

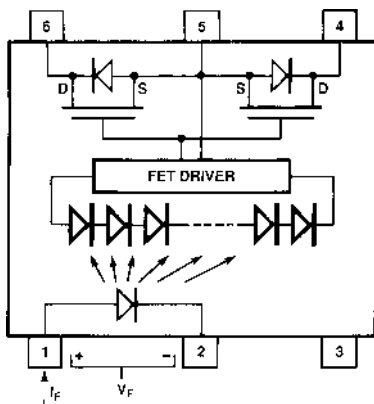

Figure 1. Circuit Diagram of HSSR-8060/8400.

sufficient voltage and current to operate the FET driver circuit and also to drive the gate-to-source voltages above the thresholds of the two output FETs. This application note describes the main characteristics of the HSSR-8060 and HSSR-8400, suggests a control drive circuit, and presents various applications for the SSRs. Additional information regarding SSRs in general can be found in Agilent's Application Note 1036.

### Summary of Characteristics

The HSSR-8060/8400 is packaged in a 6-pin DIP, but only five pins are used. Pins one and two are the anode and the cathode of the input LED, respectively. Pins four, five, and six, at the output side of the SSR, can be configured as either Connection A or Connection B as shown in Figure 2. With Connection A, the signal at the output of the SSR can have either positive or negative polarity. This means that the SSR can pass either ac or dc signals. With Connection B, the signal at the output of the SSR must have its polarity as indicated in Figure 2b. In this configuration, pins 4 and 6 are tied together, and the SSR can control dc signals only. The

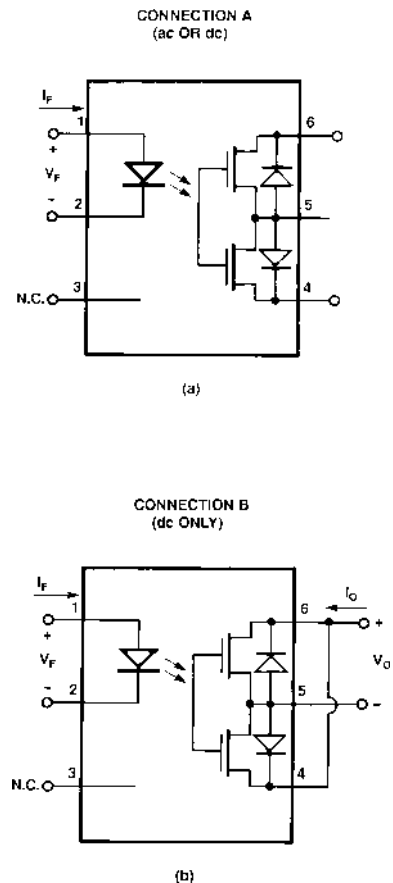

Figure 2. HSSR-8060/8400 Schematic.

advantage of using Connection B is that it places the two output FETs in parallel with each other, rather than in series.

This configuration reduces the output on-resistance of the SSR significantly and increases its output current capability by a factor of two. Figure 2 also defines the polarity for the input side of the SSR. The HSSR-8060/8400 turns on (its contact closes) with a minimum input current,  $I_F$ , of 5 mA at a typical forward voltage,  $V_F$ , of 1.6 V. Operation at higher currents causes faster closure of the contacts. The SSR turns off (its contact opens) when  $V_F$  is equal to 0.8 V or less.

Both the HSSR-8060 and the HSSR-8400 have guaranteed input-to-output insulation voltage ratings of 2500 Vac, 1 minute. Additionally, the HSSR-8060 has an output transient rejection of 1000 V/ $\mu$ s at 60 V, and the HSSR-8400 has an output transient rejection of 1000 V/ $\mu$ s at 100 V. The input-to-output transient rejection specification of both SSRs is 2500 V/ $\mu$ s at 1000 V.

The HSSR-8060 has an output withstand voltage rating of 60 V at room temperature. If the SSR is used as shown in Connection A to pass ac signals, then 60 V is the maximum amount of peak positive or negative voltage that should be applied across the output contact. The HSSR-8060 is distinguished by its low on-resistance,  $R_{(on)}$ , and large output current capability,  $I_O$ . At room temperature, with Connection A, the maximum on-resistance of the HSSR-8060 is 0.7 ohm, and the average output current rating is 0.75 A. With Connection B, the on-resistance is reduced to 0.2 ohm and the average output current rating is increased to 1.5 A. As mentioned in the data sheet, the on-resistance specification for both the HSSR-

8060 and HSSR-8400 refers to the resistance measured across the output contact when a pulsed current signal is applied to the output pins. The use of a pulsed current signal ( $\leq 30$  ms) implies that each junction temperature is equal to the ambient and case temperatures.

The HSSR-8400 has an output withstand voltage of 400 V at room temperature. If the SSR is used as shown in Connection A to pass ac signals, then 400 V is the maximum amount of peak positive or negative voltage that should be applied across the output contact. Similar to the HSSR-8060, the HSSR-8400 has a low on-resistance and large output current rating. At room temperature, the maximum on-resistance value is 10 ohms, and the average output current capability is 0.15 A. With Connection B, the maximum on-resistance is 2.5 ohms and the average output current rating increases to 0.3 A.

The output current rating of an electromechanical relay (EMR) is usually limited by its ability to interrupt that current when opening. The output current rating of the HSSR-8060/8400, on the other hand, is limited by the highest junction temperature (125°C) its MOSFETs can withstand. This junction temperature is a function of the on-resistance, the load current, the thermal resistances, and the ambient temperature. As the junction temperature rises, the on-resistance also rises. To limit power dissipation at higher case and ambient temperatures, the output current rating must then be derated. It is important for SSR specifications to include this derating effect. The data sheets

for both the HSSR-8060 and HSSR-8400 include graphs that show the effect of temperature on the output current rating,  $I_O$ . If these SSRs are operated within the "safe area of operation" indicated on these current derating graphs, the corresponding "power versus temperature" graph illustrates the maximum amount of power dissipated by the SSR. Operation within this area ensures that the steady-state junction temperatures remain below 125°C.

The output current derating graphs for the HSSR-8060 are shown in Figure 3. The output power dissipation versus case temperature graph is shown in

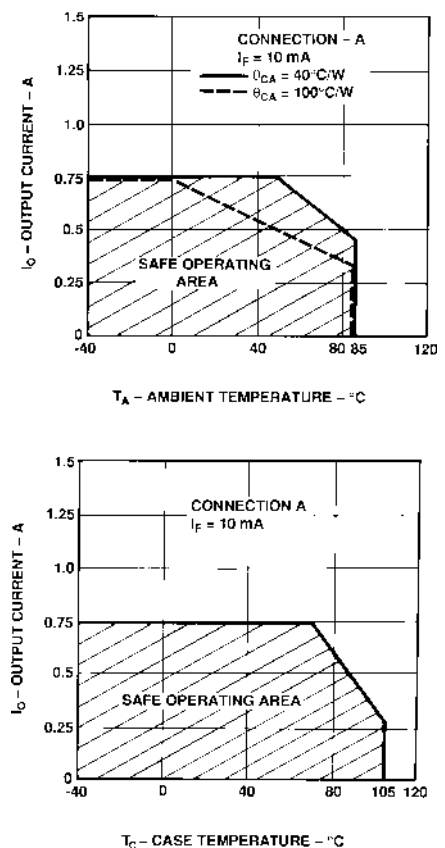
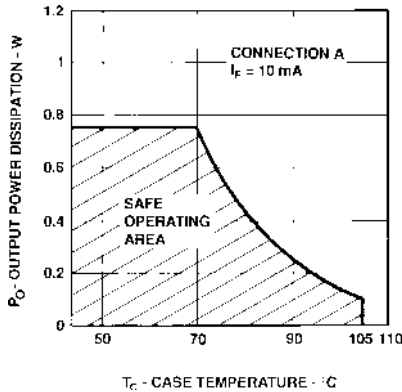

Figure 3. HSSR-8060 Output Current Derating Graphs.



**Figure 4. Output Power Dissipation vs. Case Temperature.**

Figure 4. The following example uses these graphs to calculate the MOSFET junction temperatures and the maximum recommended value of the case-to-ambient thermal resistance,  $\theta_{C-A}$ .

Designer's specifications:

- HSSR-8060, Connection A
- $I_O = 500\text{mA}$
- $T_A = 25^\circ\text{C}$

Data sheet specification:

- Typical Output MOSFET
- $\theta_{J-C} = 55^\circ\text{C/W}$

For this example, assume that the above conditions have been specified by the designer. According to Figure 3b, for  $I_O = 500\text{ mA}$ , the maximum case temperature allowed is  $86^\circ\text{C}$ . At  $T_C = 86^\circ\text{C}$ , the maximum output power dissipation is  $0.3\text{ W}$ , according to Figure 4. Therefore, the maximum power dissipated by each MOSFET is  $0.15\text{ W}$ . Hence, the maximum junction temperature of each MOSFET is as follows:

$$\begin{aligned} T_J &= \theta_{J-C}(P_O) + T_C \\ &= 55^\circ\text{C/W}(0.15\text{ W}) + 86^\circ\text{C} \\ &= 94.25^\circ\text{C} \end{aligned}$$

Now, to calculate the maximum recommended  $\theta_{C-A}$ , the following

formula must be used:  $\theta_{C-A} = [(T_C - T_A)/P_{\text{total}}]$ . The maximum power dissipated by the input LED is equal to  $[(I_F)(V_F)] = [(10\text{ mA})(1.85\text{ V})] = 0.019\text{ W}$ . Therefore, the total power dissipated by the SSR must be less than  $0.319\text{ W}$ . Hence, the value of  $\theta_{C-A}$  must be no greater than  $[(86 - 25)/0.319]$ , or  $191.22^\circ\text{C/W}$ . This will ensure that  $T_C$  remains below  $86^\circ\text{C}$ . One suggestion for minimizing  $\theta_{C-A}$  is to enlarge the pc-board copper traces surrounding the output pins of the SSR. Another suggestion is to force cool airflow across the board.

### Maximum Signal Frequency

When using the HSSR-8060/ 8400 to control ac signals, the maximum frequency of the signal may be limited by the off-capacitance,  $C_{\text{off}}$ , of the relay. The off-capacitance is voltage dependent and is specified as  $135\text{ pF}$  typical for the HSSR 8060 and  $60\text{ pF}$  typical for the HSSR-8400 at  $V_O = 25\text{ V}$ . The data sheets for both SSRs include graphs for the typical output capacitance versus output voltage. Besides the off-capacitance, the maximum signal frequency depends on the load impedance, the circuit configuration, and the amount of attenuation required by the designer. The attenuation refers to

the amount of signal passed through the contact in its OFF state versus its ON state. For example,  $-40\text{ dB}$  of attenuation implies that the current that passes through the contact in its OFF state will be one hundred times smaller than the current that passes through the contact in its ON state.

For comparison, typical SSRs were configured as simple series switches and tested at room temperature for maximum signal frequency. Each SSR was tested with a load resistor,  $R_L = 100\text{ ohm}$  and an output sine wave,  $V_O = 1\text{ Vp-p}$ . The maximum signal frequency of each SSR to obtain a signal attenuation of  $-40\text{ dB}$  was as follows:

- HSSR-8060:  $40\text{ kHz}$
- HSSR-8400:  $65\text{ kHz}$
- HSSR-8200:  $2800\text{ kHz}$

The HSSR-8200 is another SSR made by Agilent Technologies. It has a very low  $C_{\text{off}}$  specification of  $4.5\text{ pF}$  maximum.

Figures 5a and 5b show a circuit model and its off-state equivalent circuit for a simple series switch using an SSR. The frequency response of this circuit is shown in Figure 6. The break frequency,  $f_B$ , is the frequency above which there is no attenuation in the signal.

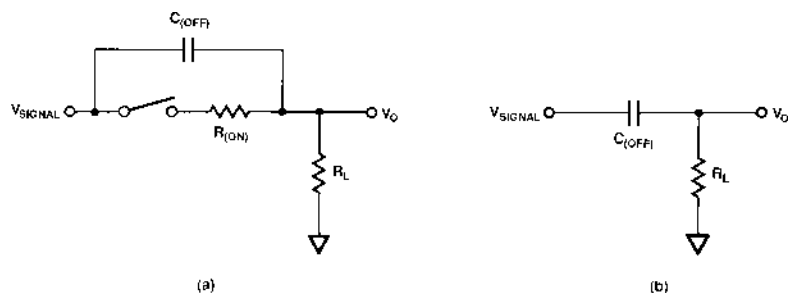

**Figure 5. Simple Series Configuration.**

This means that the same amount of signal will pass through the contact whether it is opened or closed. As shown in Figure 6, the signal amplitude decreases by 20 dB for each decade decrease in the signal frequency. A designer who requires -40 dB of attenuation when the SSR is off must have a maximum signal frequency that is at least two decades below the break frequency. As an example, the break frequency is about 800 kHz for a load resistance,  $R_L$ , of 1 k $\Omega$  and a  $C_{(off)}$  of 200 pF. If a designer requires at least -40 dB of attenuation when the relay is off, the maximum signal frequency is two decades below 800 kHz, or 8 kHz.

To control higher-frequency signals, two SSRs can be used in the series-shunt configuration shown in Figure 7a. In the ON state, the series SSR is closed, and the shunt SSR is opened. In the OFF state, the series SSR is opened and the shunt SSR is closed. Figure 7b shows the equivalent circuit for this OFF condition, and Figure 8 illustrates its frequency response. This series-shunt configuration produces a higher break frequency than the simple series configuration. The reason for this improvement is that the break frequency equation now uses the low on-resistance value of the SSR rather than the load resistance value. The series shunt configuration allows higher signal frequencies to be used or gives increased attenuation at lower signal frequencies. As an example, using two relays with  $C_{(off)} = 200$  pF,  $R_{(on)} = 6$   $\Omega$ , and  $R_L = 1$  k $\Omega$ , the break frequency for the series-shunt configuration is about 66 MHz.

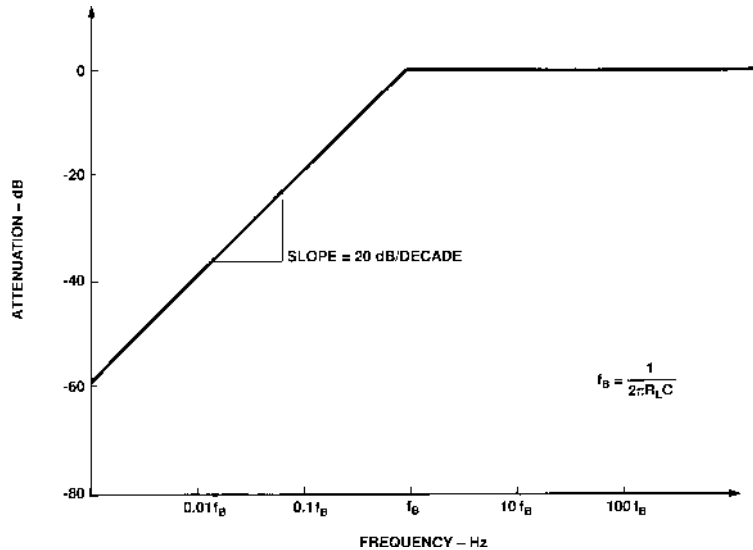

Figure 6. Simple Series Frequency Response.

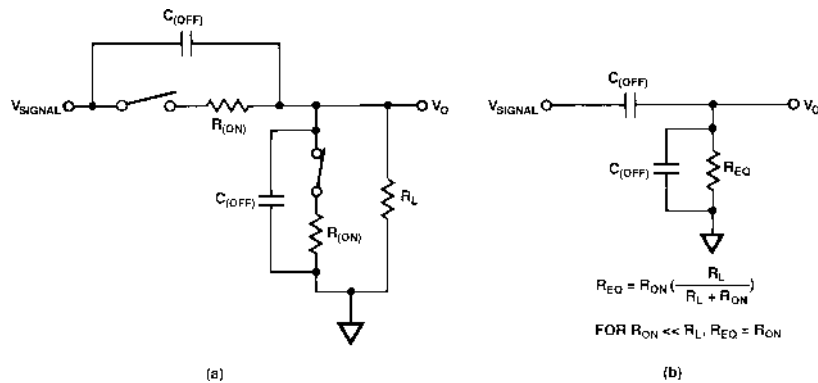

Figure 7. Series-Shunt Configuration.

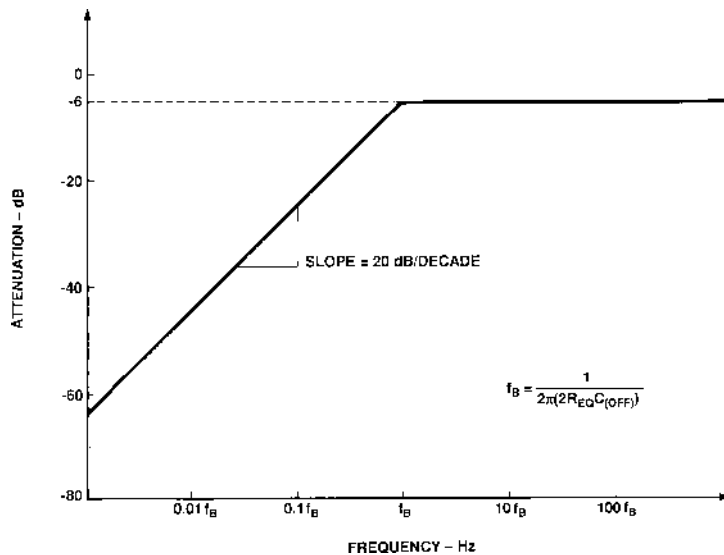

Figure 8. Series-Shunt Frequency Response.

The maximum signal frequency to ensure at least -40 dB of attenuation is approximately two decades below 66 MHz, or 660 kHz. Notice that because  $R_{(on)} \ll R_L$ , the value of the load resistance has virtually no effect on the calculation of the break frequency.

### Control Drive Circuit Suggestions

Operation of the HSSR-8060/8400 requires at least 5 mA of input current. A larger amount of input current results in faster turn-on of the SSR and a slightly faster turn-off. A simple circuit for obtaining the desired ON current and OFF voltage is shown in Figure 9. The logic series used can be either TTL or CMOS, as long as the current sinking capability is adequate. Resistor R1 sets the level of steady-state input current,  $I_F$ . The purpose of R2 is to bypass logic-high leakage current with sufficiently small voltage drop to ensure an OFF-voltage less than 0.8 V. R2 is not required if the logic output has an internal pullup circuit that is able to satisfy the OFF-voltage requirement of the SSR. With open collector TTL outputs, R2 is always required to ensure that  $V_{F(OFF)} < 0.8$  V.

As mentioned earlier, turn-ON time is influenced by the level of input current. As input current is increased, the turn-ON time becomes shorter. However, it may not be desirable to operate with a high steady-state input current because that would increase the output offset voltage,  $V_{OS}$ , due to heat transferred from the LED control to the contact side. Also, a lower steady-state current minimizes input power consumption. In situations requiring fast

turn-ON but low offset, the peaking circuit shown in Figure 9 can be used. When the logic output is high, R2 assures that the current through the LED is so small that the capacitor is completely discharged. Then when the logic output goes low, a surge of current flows through both R1 and R3 until the capacitor is charged to the voltage across R1. The steady-state current is set by R1 alone. Thus peaking permits fast turn-ON as well as low steady-state current. Table 1 shows the typical turn-on times obtained with different values of resistor R3.

Turn-on of the output MOSFETs requires charging the gate capacitances in the FET

DRIVER circuit. This charge is the time-integrated photocurrent from the photodiode array, and translates into a certain amount of current that must pass through the LED. The corresponding amount of LED charge is set by the value of the peaking capacitor and the voltage across R1. For this reason, it is not necessary to change the value of the capacitor when other values of peak current are desired; it is necessary only to change the value of R3 and make sure that the logic output is capable of sinking the higher current.

### Telecommunication Applications

SSRs are commonly used by the telecommunications industry. Some examples of applications

**Table 1. Typical Peaked Turn-on Times.**

R <sub>3</sub> (Ω)	I <sub>F(PEAK)</sub> (mA)	HSSR-8060 t <sub>ON</sub> (ms)	HSSR-8400 t <sub>ON</sub> (ms)
–	10 (No Peak)	0.93	0.50
330	20	0.53	0.29
100	40	0.32	0.17
33	100	0.17	0.09

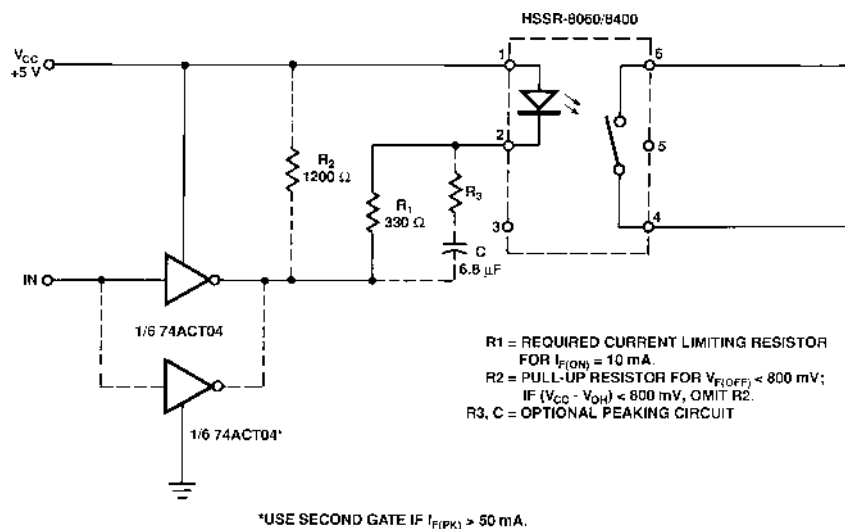

**Figure 9. Recommended Input Circuit.**



include on/off-hook switching, test and maintenance equipment, PBX and central-office switching, and pulse dialing. Compared to EMRs, SSRs are useful in these areas because they are small and require little board space. They have no mechanical parts so they last longer, thereby increasing the number of operations that can be performed. In addition, SSRs have no contact bounce, arcing, or acoustic noise.

In telephone loop applications, it is often necessary to isolate the telephone equipment from the incoming telephone lines. Isolation is important to protect the electronics from harmful voltages and currents induced from lightning or noise coupled onto the lines. Modern line interface circuits, such as those used for modems and fax machines, consist of a ring detector, an on-off hook control, isolation, and surge protection. An advantage of using an SSR as the on-off hook switch is that it provides both high-voltage isolation and surge protection. Figure 10 shows the SSR in a telephone switchhook application. In the ON-state, the SSR's contact on-resistance contributes to the total impedance of the telephone loop, which is between 500 and 2100 ohms. Therefore, the on-resistance should be as small as possible. At room temperature, the HSSR-8060 has a maximum on-resistance of 0.7 ohm, and the HSSR-8400 has a maximum on-resistance of 10 ohms.

The purpose of the on-off hook switch is to connect or disconnect the telephone equipment from the PBX (private branch exchange) or

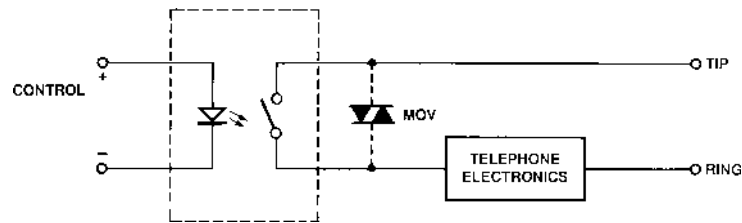

Figure 10. Telephone Switchhook.

the PSTN (public switched telephone network). When a person wishes to place an outgoing call or answer an incoming call, the relay is turned on to allow current to flow between the tip and ring conductors. In this relay application, an overvoltage protection device is often required to protect the contact from possible lightning damage. For example, a metal oxide varistor (MOV™) is a bidirectional device that breaks down and conducts heavily when the voltage across it rises above a threshold level. As shown in Figure 10, an MOV is placed across the output contact of the SSR. The device protects the SSR by limiting the tip-to-ring voltage to a value below the maximum load voltage of the SSR. The MOV acts as a Zener diode but dissipates more energy. When a large current surge occurs, the “Zener” voltage of the MOV can cause significant overshoot. For this reason, the SSR's load voltage must be higher than the highest voltage of the protection device at any given current surge. Most of the SSRs used in telephone-line interface applications are rated for at least 350 to 400 volts. The HSSR-8400 has a high contact withstand voltage rating of 400 V.

Telecommunication companies may also use SSRs for test and maintenance equipment. When a subscriber reports a problem with his or her telephone service, the telephone company can use relays to switch test equipment onto the line to verify the problem. Telephone companies might also use relays to switch test equipment onto a line to examine the quality of the line. This is done to locate potential problems. Another application for SSRs in the telecom industry is in PBXs and Central Office Switching Stations. SSRs may be used to multiplex incoming signals, such as concentrating several subscriber loops onto a single interface circuit. Or, SSRs may be used in the cross-point matrixes of these switching stations.

In a telephone line interface, SSRs can also be used for the pulse dialing function. With pulse dialing, a relay is used to interrupt the line current. The number of line interrupts corresponds to the specific digit that was dialed. A “1”, for example, is identified by one break while a “9” is identified by nine breaks in the line.

## Multiplexing

Sometimes, signals that need to be measured require amplification or conversion. As shown in Figure 11, multiplexing allows a single device to process a number of signals. This technique reduces cost by using one device for a number of channels rather than one device per channel. Also, multiplexing ensures that the same amount of gain is applied to each signal so that the ratios of the amplified levels  $V_1...V_n$  will relate to ratios of their unamplified counterparts,  $E_1...E_n$ . Compared to EMRs, SSRs are especially useful in multiplexing applications because of their increased life and reliability. Also, their fast switching speeds allow more efficient multiplexing of signals. The HSSR-8060/ 8400 have turn-on times under 1.8 ms and turn-off times under 0.1 ms. Both relays will turn on faster using the peak circuit mentioned earlier.

In any application, it is important for the amount of current passed through the contact in its OFF state to be negligible with respect to the actual amount of current being controlled. With power switching applications, the leakage current of the SSR is small relative to the amount of current being switched. In signal switching applications, however, the amount of current controlled by the SSR is relatively low. Therefore, the SSR should have negligible leakage current. When multiplexing or switching low-level signals such as thermocouple outputs, an SSR with a low leakage specification is preferred. The HSSR-8060 has a typical output leakage current of 0.1 nA, and the HSSR-8400 has a typical output leakage current of

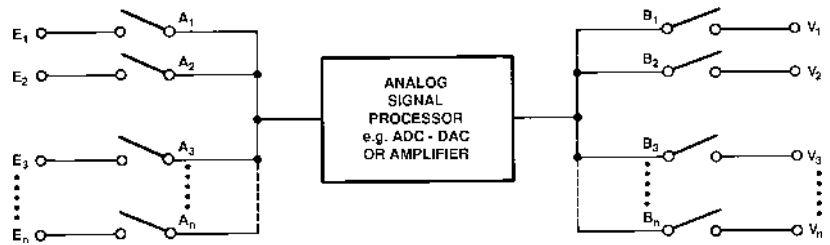

Figure 11. Multiplexing and Demultiplexing.

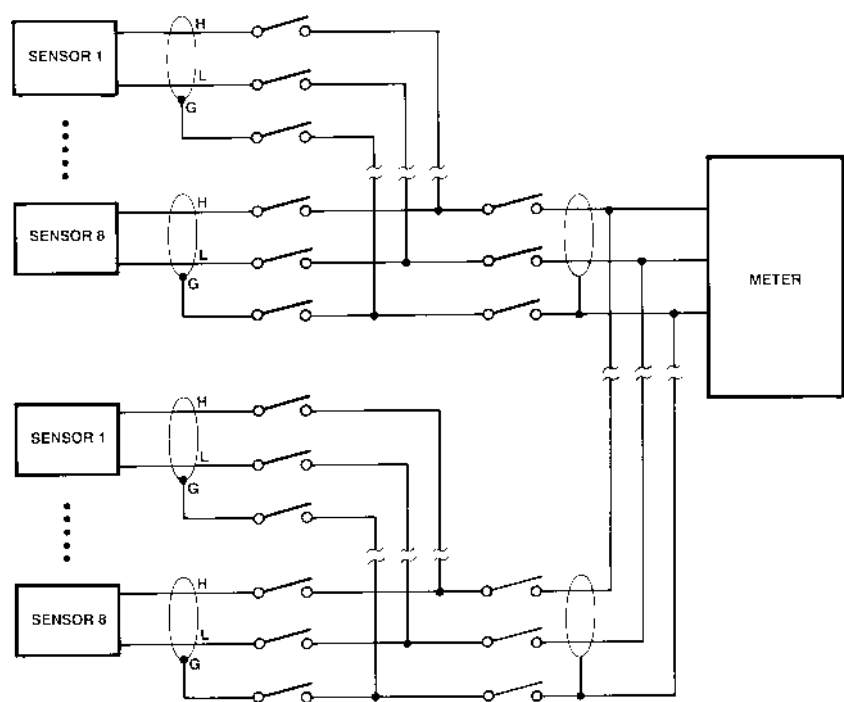

Figure 12. Multiplex System.

0.6 nA. Figure 12 shows an example of a multiplexing system. In this diagram, SSRs are used to multiplex or scan low-level differential signals. The configuration uses three switches per channel to connect the signal HI, signal LO, and guard to the measurement system. In Figure 13, SSRs are used in a flying capacitor circuit.

When relays 1 and 2 are closed, the voltage is acquired from the sensor and stored across the capacitor. After relays 1 and 2 open, relays 3 and 4 close, and the signal is read by the multiplexer. A number of sensors can be connected to the multiplexer in this fashion.

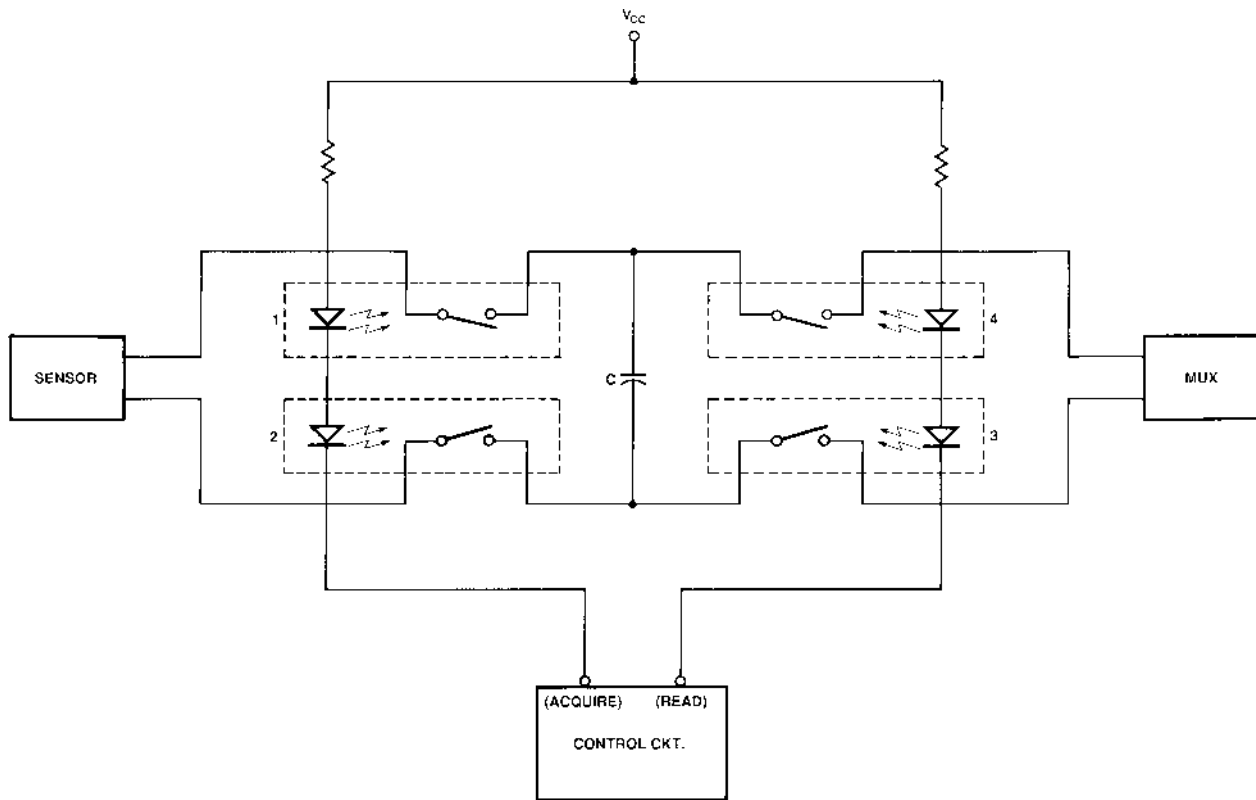

Figure 13. Flying Capacitor Multiplexer.

### Industrial Control

In programmable controllers, input and output modules allow microprocessors to sense and control various loads. An ac input module generates a logic level voltage corresponding to the presence or absence of an ac load voltage. Likewise, a dc input module generates a logic level voltage corresponding to the presence or absence of a dc load voltage. Input modules receive signals from a variety of instruments on the factory floor,

including robotics assembly equipment, chemical process units, injection molding systems, and so forth. An ac output module allows logic-level voltages to control a switch that turns ac loads on and off. For example, the output module of a process controller might be used to control the motor starters of adjustable frequency drives, position valves, or dampers. A dc output module allows logic level voltages to control a switch that turns dc loads on and off.

Figure 14 shows an example of a six-channel ac output module. The HSSR-8060/8400 may be used to sense and control signals in any one of these input and output modules.

Another application for SSRs in industrial control equipment is on scanner cards or matrix cards. These cards may be used in larger instruments such as programmable thermometers, temperature scanners, and multimeters. Scanners are very similar to



multiplexers, however scanners measure sequentially while multiplexers allow any order. Figure 15 shows an example of relays used on a matrix card. In this configuration, a number of sources can be connected, through the device under test (DUT), to a number of measurement devices.

In an automated test system, such as a data acquisition unit, efficient switching is important. In addition to their fast switching speeds, SSRs provide high voltage isolation, which is often required in industrial environments. Another benefit of SSRs in industrial control applications is that they do not have mechanical contacts, which could eventually deteriorate from arcing or dust particles.

### Various Loads

Depending on the type of load, an SSR may be required to withstand a substantial amount of surge current. A purely resistive load is the easiest type for an SSR to switch since it has no surge current requirement. Other typical loads of the HSSR-8060/8400 and their related inrush versus steady state currents are shown in Table 2.

The surge requirement of the load should be within the peak surge current rating of the relay. Therefore, an SSR that switches one of these types of loads should have current specifications that

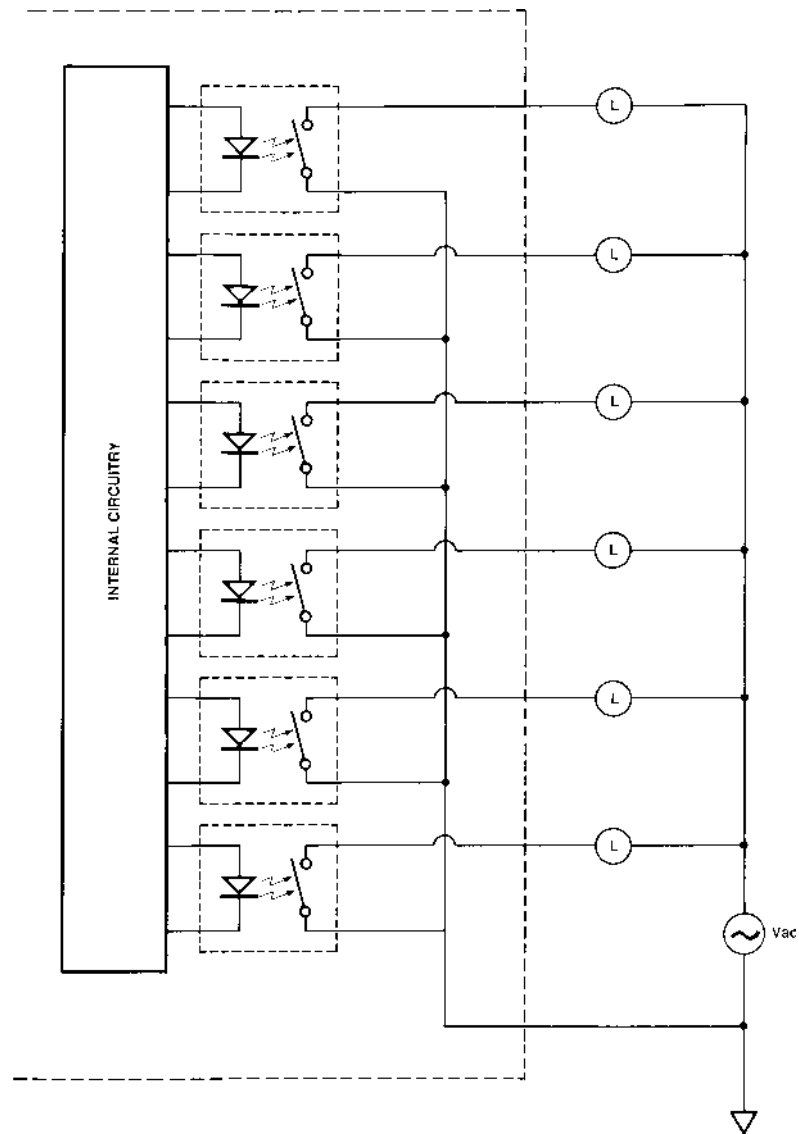

Figure 14. Six-Channel AC Output Module.

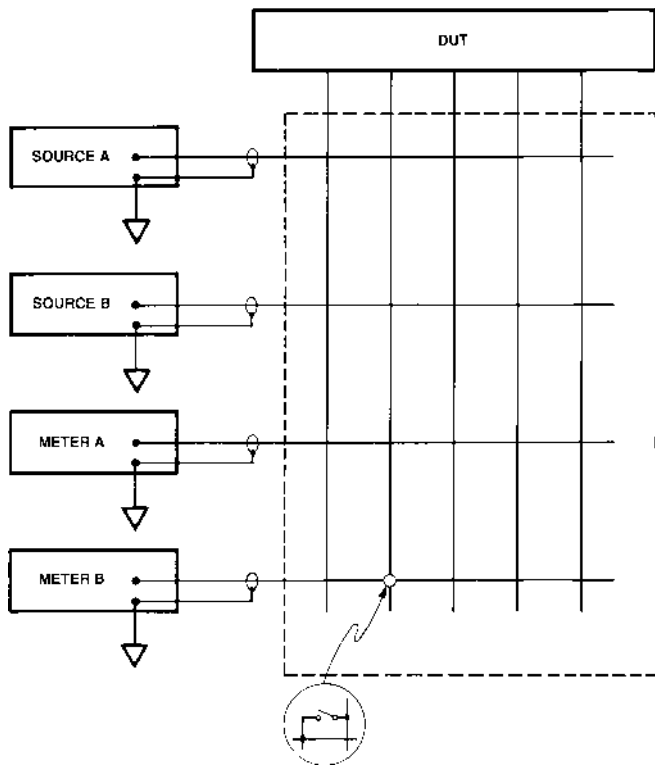

Figure 15. Matrix Card Example.

meet both the steady-state and surge requirements. Compared to EMRs, SSRs are more tolerant of surge currents because they do not have contact bounce, which results in arcing with EMR contacts. The high-temperature arc could cause melting and eventual degradation of the EMR contact. With Connection A, the HSSR-8060 has a single shot, peak output current rating of 3.75 A for a 100 ms pulse width. The HSSR-8400 has a rating of 1.0 A for a 100 ms pulse width. For longer pulse widths, the single-shot, peak output current rating would decrease. Figures 16 and 17 show the results of an experiment performed on seventy units of the HSSR-8060 and HSSR-8400. Each graph shows the peak surge current values that we were able to apply to the output of seventy typical SSRs without any one of them failing.

Table 2. HSSR-8060/8400 Load Types.

Load Type	Typical Inrush vs. Steady State Current	Inrush Duration
Small Solenoid	10-20X	70-100 ms
Fractional Horsepower Motor	5-10X	200-500 ms
Miniature Incandescent Lamp	20-15X	30-100 ms
Capacitive Load	20-40X	10-40 ms

Another experiment was conducted to determine the maximum repetitive surge current that twenty typical SSRs could withstand. Ten units each of the HSSR-8060 and HSSR-8400 were tested for fifteen minutes each with surge current pulses applied for 100 ms at 100 ms intervals (fifty percent duty cycle). Under these conditions, the maximum repetitive surge current to failure was 1.2 A for the HSSR-8060 and 0.25 A for the HSSR-8400.

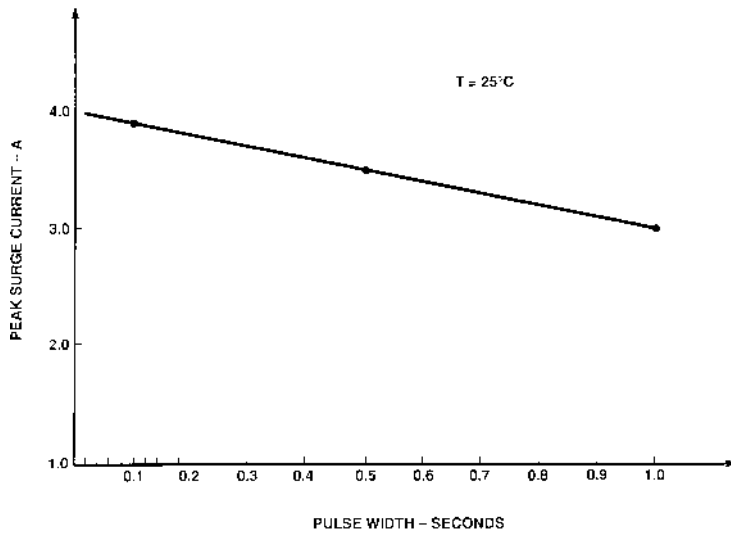

Figure 16. HSSR-8060 Peak Surge Current Experiment Results.

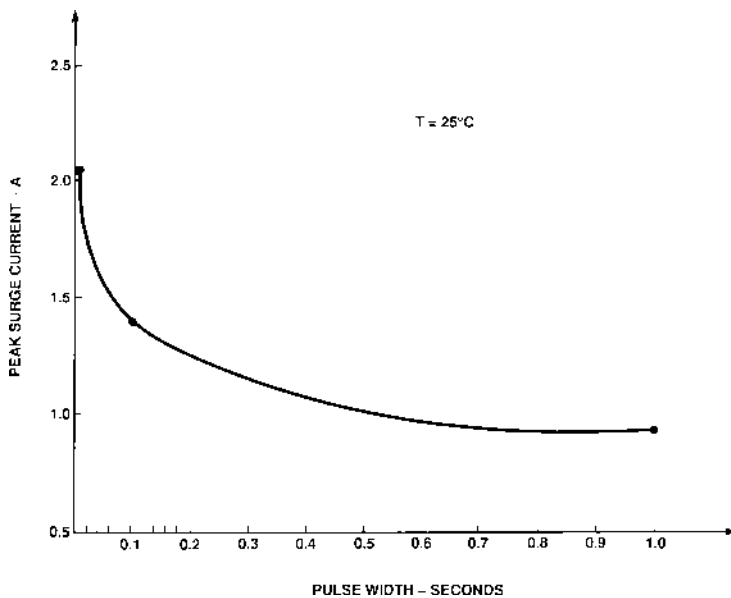

Figure 17. HSSR-8400 Peak Surge Current Experiment Results.

Figure 18 illustrates the use of SSRs in a lamp sequence control. Some areas that use SSRs to control lamp loads include process equipment, navigational devices, illuminated signs, and games. In aircraft applications, SSRs may control lamps for cabin lighting, instrumentation lighting, and status indicators. Compared to EMRs, SSRs are especially useful in aircraft environments because they are immune to shock and vibration and are unaffected by electro-magnetic interference. Upon turn-on, the current through a lamp is very high initially because of the Tungsten filament's low resistance at room temperature. The current decreases as the filament heats up. Hence, the inrush current can be reduced by using a "keep alive" voltage across the filament to keep it warm but below the level of incandescence.

Similar to a lamp load, a capacitive load will cause a surge current to flow through the output MOSFETs of the SSR, upon initial turn-on. This surge current will depend on the load capacitor value and the rate of rise of the load voltage. In addition, the frequency at which the SSR is switched will affect the output power dissipation. Ten units of the HSSR-8060 were tested at room temperature under the following conditions:

- Input current,  $I_F = 10 \text{ mA}$  (1 Hz)
- Load,  $C = 100 \mu\text{F}$  capacitor
- Load voltage,  $V = 60 \text{ V}$

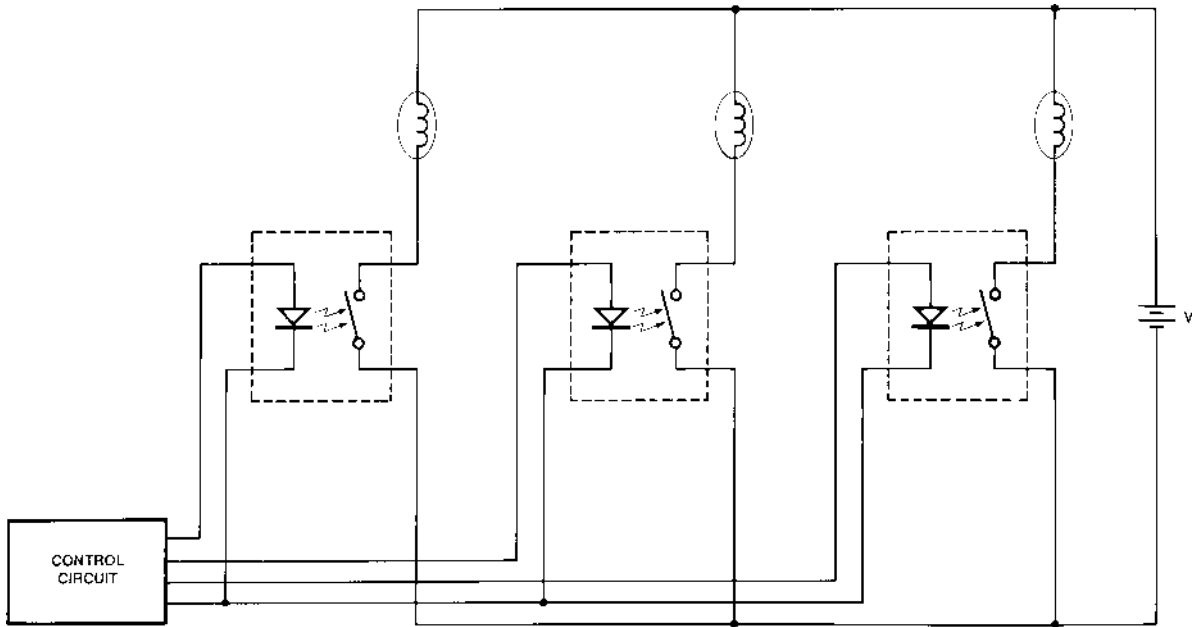

Figure 18. Lamp Control.

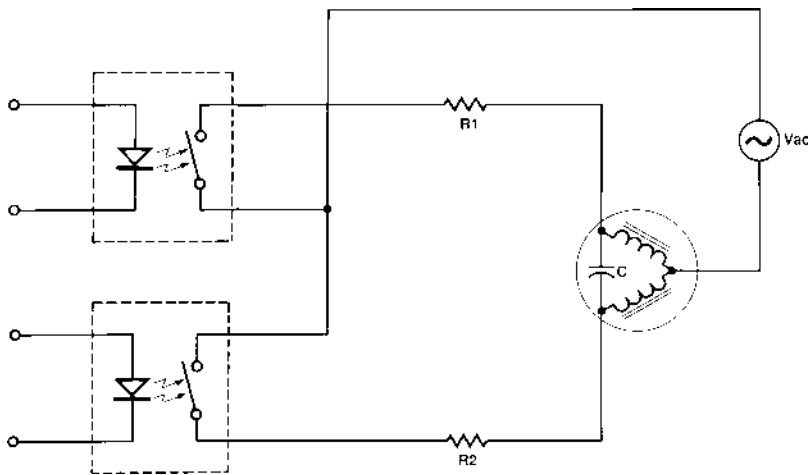

Figure 19. Motor Reversing Control.

The load capacitor was charged by the load voltage through an 80-ohm series resistor. The output of the SSR-under-test was placed in parallel with the capacitor to discharge it. After the testing, each SSR was tested for 1.2 million cycles and passed. There were no catastrophic failures or parameter drifts.

The HSSR-8060/8400 can be used to drive fractional horsepower motors. A reversing control for a synchronous ac motor is shown in Figure 19. For motors that cycle on and off frequently, an SSR is often preferred over an EMR because it can handle surges better and does not produce EMI. An SSR might also be used to control small dc motor loads such as those used in computer disk drives, audio and video equipment, household electronics, or automotive electronics.

An SSR may be used to control the input coil of an EMR, which is a highly inductive load. Other inductive loads include small transformers, contactors, solenoid valves, magnetic couplings, etc. When SSRs drive inductive loads, very high peak voltages can occur across the output when switching off the loads. The MOSFETs in the output of the SSR are able to withstand a reasonable amount of inductive overload. For example, ten units of the HSSR-8060 were tested at room temperature under the following conditions:

Input current,  $I_F = 10 \text{ mA}$  (1 Hz)  
 Load,  $L = 1\text{-H}$  inductor  
 Load voltage,  $V = 60 \text{ V}$   
 Load current = 670 mA

Each unit was tested for one million cycles and passed. There were no catastrophic failures or parameter drifts. No overvoltage protection for the SSR was

used in this experiment. However, overvoltage protection is recommended whenever the chance exists for an event where both the withstand voltage rating and output power dissipation or surge rating are exceeded, or where the energy content of the transient is very large as in lightning-induced events.

### Overvoltage Protection

Metal oxide varistors (MOVs) or TransZorbs™ can be used for overvoltage protection of the contacts of an SSR. They both break down and conduct heavily when the voltage across them rises above a specified level. For ac voltages, either an MOV or a bidirectional TransZorb can be used. Both devices fail “short” so that protection is always in place, even though operation may cease. As shown in Figure 20, the protection device is placed across the output contact

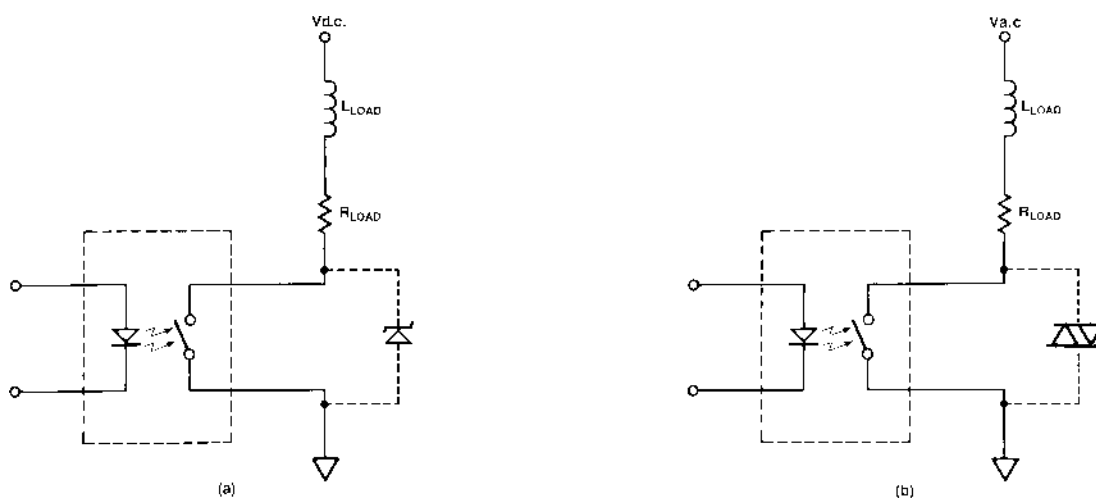

Figure 20. Overvoltage Protection.

pins of the relay and is used when the contact is susceptible to voltages greater than the rated output withstand voltage,  $V_O$ . For adequate protection of the contact, the protection device should be in a fully conductive state at a voltage just below the maximum output voltage. However, it must be in a high-impedance state for any voltage below the maximum line voltage.

When the SSR is used to control small dc voltages, a single Zener diode, illustrated in Figure 20a, provides adequate protection. Again, the clamp voltage of the Zener should be greater than the controlled voltage but less than the maximum rating of the SSR contact.

<sup>TM</sup> MOV is a registered trademark of GE/RCA Solid State.

TransZorb is a registered trademark of General Semiconductors.





*www.semiconductor.agilent.com*

Data subject to change.

Copyright © 1999 Agilent Technologies, Inc.

Obsoletes 5091-3123E

5965-5978E (11/99)

SUNSTAR 商斯达实业集团是集研发、生产、工程、销售、代理经销、技术咨询、信息服务等为一体的高科技企业，是专业高科技电子产品生产厂家，是具有 10 多年历史的专业电子元器件供应商，是中国最早和最大的仓储式连锁规模经营大型综合电子零部件代理分销商之一，是一家专业代理和分销世界各大品牌 IC 芯片和电子元器件的连锁经营综合性国际公司，专业经营进口、国产名厂名牌电子元件，型号、种类齐全。在香港、北京、深圳、上海、西安、成都等全国主要电子市场设有直属分公司和产品展示展销窗口门市部专卖店及代理分销商，已在全国范围内建成强大统一的供货和代理分销网络。我们专业代理经销、开发生产电子元器件、集成电路、传感器、微波光电元器件、工控机/DOC/DOM 电子盘、专用电路、单片机开发、MCU/DSP/ARM/FPGA 软件硬件、二极管、三极管、模块等，是您可靠的一站式现货配套供应商、方案提供商、部件功能模块开发配套商。商斯达实业公司拥有庞大的资料库，有数位毕业于著名高校——有中国电子工业摇篮之称的西安电子科技大学（西军电）并长期从事国防尖端科技研究的高级工程师为您精挑细选、量身订做各种高科技电子元器件，并解决各种技术问题。

微波光电部专业代理经销高频、微波、光纤、光电元器件、组件、部件、模块、整机；电磁兼容元器件、材料、设备；微波 CAD、EDA 软件、开发测试仿真工具；微波、光纤仪器仪表。欢迎国外高科技微波、光纤厂商将优秀产品介绍到中国、共同开拓市场。长期大量现货专业批发高频、微波、卫星、光纤、电视、CATV 器件：晶振、VCO、连接器、PIN 开关、变容二极管、开关二极管、低噪晶体管、功率电阻及电容、放大器、功率管、MMIC、混频器、耦合器、功分器、振荡器、合成器、衰减器、滤波器、隔离器、环行器、移相器、调制解调器；光电子器件和组件：红外发射管、红外接收管、光电开关、光敏管、发光二极管和发光二极管组件、半导体激光二极管和激光器组件、光电探测器和光接收组件、光发射接收模块、光纤激光器和光放大器、光调制器、光开关、DWDM 用光发射和接收器件、用户接入系统光收发器件与模块、光纤连接器、光纤跳线/尾纤、光衰减器、光纤适配器、光隔离器、光耦合器、光环行器、光复用器/转换器；无线收发芯片和模组、蓝牙芯片和模组。

更多产品请看本公司产品专用销售网站：

商斯达微波光电产品网：[HTTP://www.rfoe.net/](http://www.rfoe.net/)

商斯达中国传感器科技信息网：<http://www.sensor-ic.com/>

商斯达工控安防网：<http://www.pc-ps.net/>

商斯达电子元器件网：<http://www.sunstare.com/>

商斯达消费电子产品网：<http://www.icasic.com/>

商斯达实业科技产品网：<http://www.sunstars.cn/> 射频微波光电元器件销售热线：

地址：深圳市福田区福华路福庆街鸿图大厦 1602 室

电话：0755-83396822 83397033 83398585 82884100

传真：0755-83376182 (0) 13823648918 MSN: SUNS8888@hotmail.com

邮编：518033 E-mail:szss20@163.com QQ: 195847376

深圳赛格展销部：深圳华强北路赛格电子市场 2583 号 电话：0755-83665529 25059422

技术支持：0755-83394033 13501568376

欢迎索取免费详细资料、设计指南和光盘；产品凡多，未能尽录，欢迎来电查询。

北京分公司：北京海淀区知春路 132 号中发电子大厦 3097 号

TEL: 010-81159046 82615020 13501189838 FAX: 010-62543996

上海分公司：上海市北京东路 668 号上海赛格电子市场 D125 号

TEL: 021-28311762 56703037 13701955389 FAX: 021-56703037

西安分公司：西安高新开发区 20 所(中国电子科技集团导航技术研究所)

西安劳动南路 88 号电子商城二楼 D23 号

TEL: 029-81022619 13072977981 FAX:029-88789382