

High Speed CMOS Optocoupler Applications in Industrial Field Bus Networks

Application Note 1321

Industrial Field Bus Networks

Before field bus, an industrial control system was built up around a central controller with input and output cards to input signals from sensors and output signals to actuators. Usually, the controller, I/O cards and motor drivers were installed in the central cabinet, which was connected with the remote devices (Figure 1a).

Field bus networks, however, communicate between the controller and field devices in a sequential information manner (Figure 1b). Controllers and devices are connected to the field bus cable in bus, star, tree or ring topologies.

From the mid 1980's, field bus technology was ready to move onto the factory floor. Industrial field buses are classified according to their performance capabilities. What field bus standard one ultimately chooses chiefly depends upon the amount of data that a bus is able to handle and its associated speed or propagation delay requirements. There are perhaps dozens of popular network standards and hundreds of proprietary or home brewed standards. The development and usage of field buses has grown rapidly. During the end of 1999 and 2000, there was approval for IEC61158, which is an international standard covering several

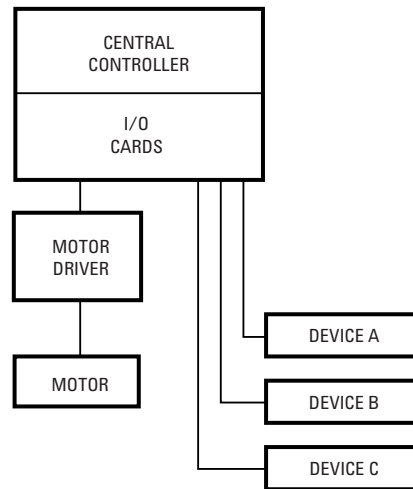

Figure 1a. Conventional controller and remote devices connected by parallel

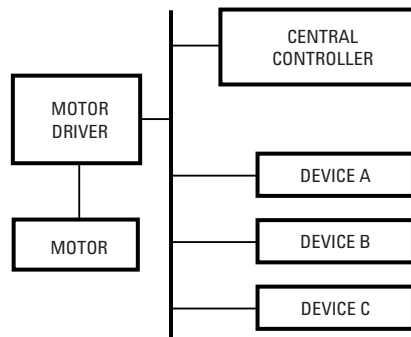

Figure 1b. Controller and remote devices connected by fieldbus network

networks in total. Appendix 1 lists a performance comparison of some popular field bus standards discussed in this application note.

Optical Isolation for Field Bus Networks

Numerous and large transient bursts are common in an industrial environment. These transient bursts can disrupt the data transmission and even potentially damage the interconnected equipment. In order to ensure error-free data transmission in high-speed field bus communication, an industry system designer has to take efforts to eliminate disturbances. Typically galvanic isolated optocouplers (Figure 2) are used to retain data integrity and protect interconnected equipment.

International standard IEC 61000-4-4 specifies electrical fast transient/burst immunity test related to the immunity requirement of EMC. All of Agilent's high-speed CMOS optocouplers have transient immunity performance CMR 10 kV/ μ s at common mode voltage up to 1000 Volts. Optocouplers isolate transient/burst interference and transmit data between bus transceiver and controller. Since network communication is bi-directional (involving receiving data from and transmitting data onto the network) two optocouplers are needed per node.



Agilent Technologies

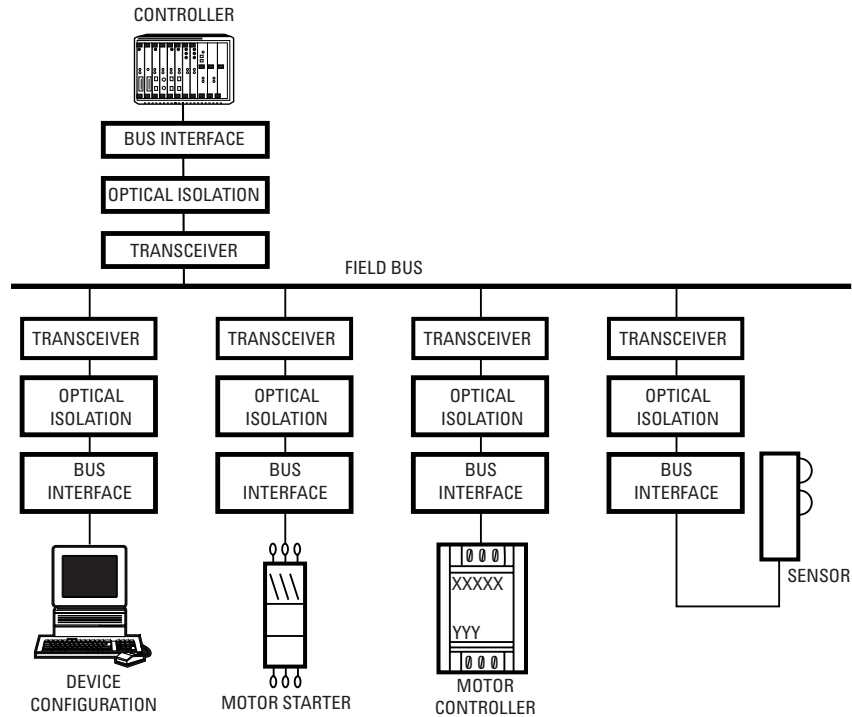

Figure 2. Field Bus Communication Physical Model

Recommended Optocouplers

The following optocouplers use the latest CMOS IC technology to achieve outstanding system

performance. The optocoupler choice will depend on the overall system requirements, with data rate and regulatory requirements playing an important role.

HCPL-	7710	0710	7720	0720	7721	0721	0708	0738	7723	0723
Speed	12.5 MBd		25 MBd				15 MBd		50 MBd	
Max. Propagation Delay	40 ns						60 ns		22 ns	
Min. Pulse Width	80 ns		40 ns				100 ns		20 ns	
Max. PWD	8 ns				6 ns		30 ns		2 ns	
Max. Propagation Delay Skew	20 ns						40 ns		15 ns	
Min. CMR	10 kV / μ s @ $V_{cm} = 1000$ V									
Package Type	300 mil DIP8	S08	300 mil DIP8	S08	300 mil DIP8	S08	S08	S08 Dual	300 mil DIP8	S08
IEC/EN/DIN EN 60747-5-2 [Viorm]	*630 Vpeak	*560 Vpeak	*630 Vpeak	*560 Vpeak	*630 Vpeak	*560 Vpeak	*560 Vpeak	*560 Vpeak	*630 Vpeak	*560 Vpeak
UL [Viso]	3750 Vrms	3750 Vrms	3750 Vrms	3750 Vrms	3750 Vrms	3750 Vrms	3750Vrms		3750 Vrms	3750 Vrms

* Option 060 required.

Isolation Node Power Supply Design Considerations

There are an AC line in device power supplies and DC power in field bus cables. It is very flexible for the isolation node to tap power from the above two sources. The basic consideration is that two power supplies must be isolated across the optocoupler isolation boundary. There are three types of solutions, namely:

1. Isolation Node Powered by the Network (Figure 3);
2. Isolation Node with Transceiver Powered by the Network (Figure 4);
3. Isolation Node Providing Power to the Network (Figure 5).

1. Isolation Node Powered by the Network

If the network power can supply the devices sufficiently, then it is not necessary to power field devices from the AC line. As seen in Figure 3, a non-isolated voltage regulator supplies the transceiver and half of two optocouplers, while an isolated DC/DC converter supplies the controller and the other side of two optocouplers.

2. Isolation Node with Transceiver Powered by the Network

Figure 4 shows when an application requires a significant amount of power. In this case, the field device is powered by the AC line while the transceiver and isolated side of the two optocouplers are powered by the

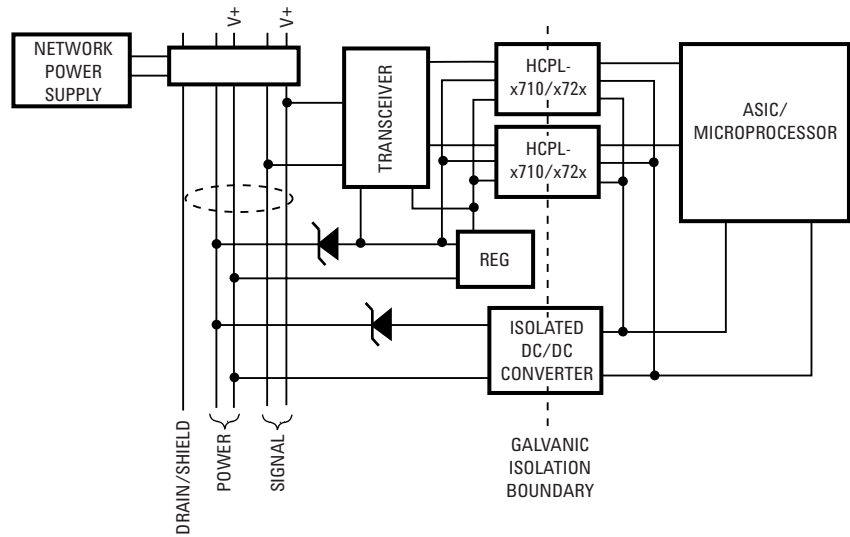

Figure 3. Isolation Node Powered by the Network

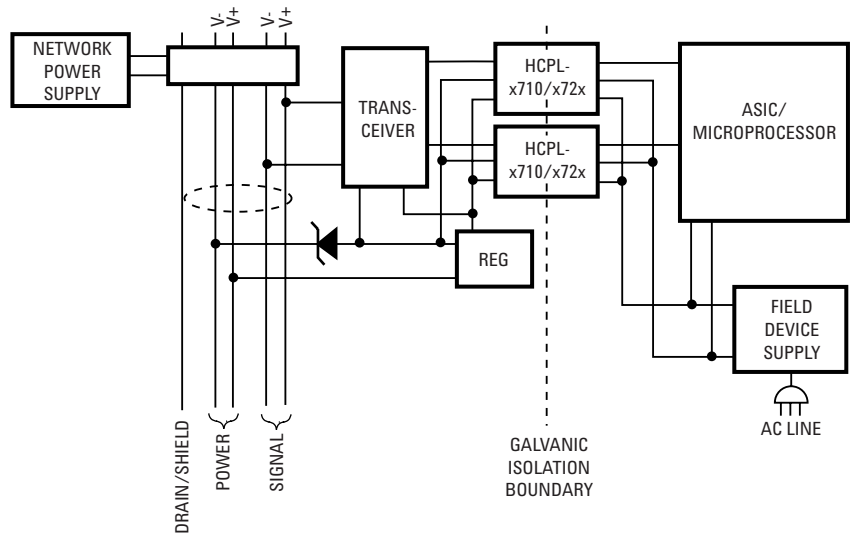

Figure 4. Isolation Node with Transceiver Powered by the Network

network. This method is also desirable as it does not heavily load the network.

3. Isolation Node Providing Power to the Network

The method shown in Figure 5 is recommended when there are a limited number of devices on the network that do not require much power, thus eliminating the need for separate network power supplies. The AC line powers the field device supply locally and also powers the isolated power supply. This supply powers the network, from which one regulator derives DC 5 V to power the transceiver and the isolated (network) side of two optocouplers.

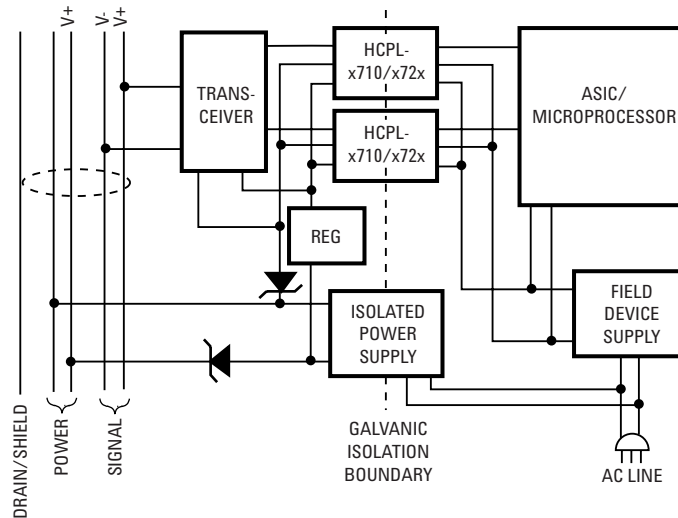

Figure 5. Isolation Node Providing Power to the Network

Recommended DeviceNet Application Circuit

A CAN bus is used by DeviceNet physical layer implementation. The recommended DeviceNet application circuit is shown in Figure 6. Since the high-speed CMOS optocouplers HCPL-x710/x72x are fully compatible with CMOS logic level signals, the two optocouplers are connected directly to the CAN transceiver. Two bypass capacitors (with values between 0.01 and 0.1 μF) are required and should be located as close as possible to the input and output power supply pins of the optocoupler. For each capacitor, the total lead length between both ends of the capacitor and the power supply pins should not exceed 20 mm. The bypass capacitors are required because of the high-speed digital nature of the signals inside the optocoupler.

More importantly, the unique “dual-inverting” design of the Agilent HCPL-x710/x72x ensures the network will not “lock-up” if either AC line power to the node is lost or the node powered-off. Specifically, when input power (V_{DD1}) to the HCPL-x710/x72x located in the transmit path is eliminated, a RECESSIVE bus

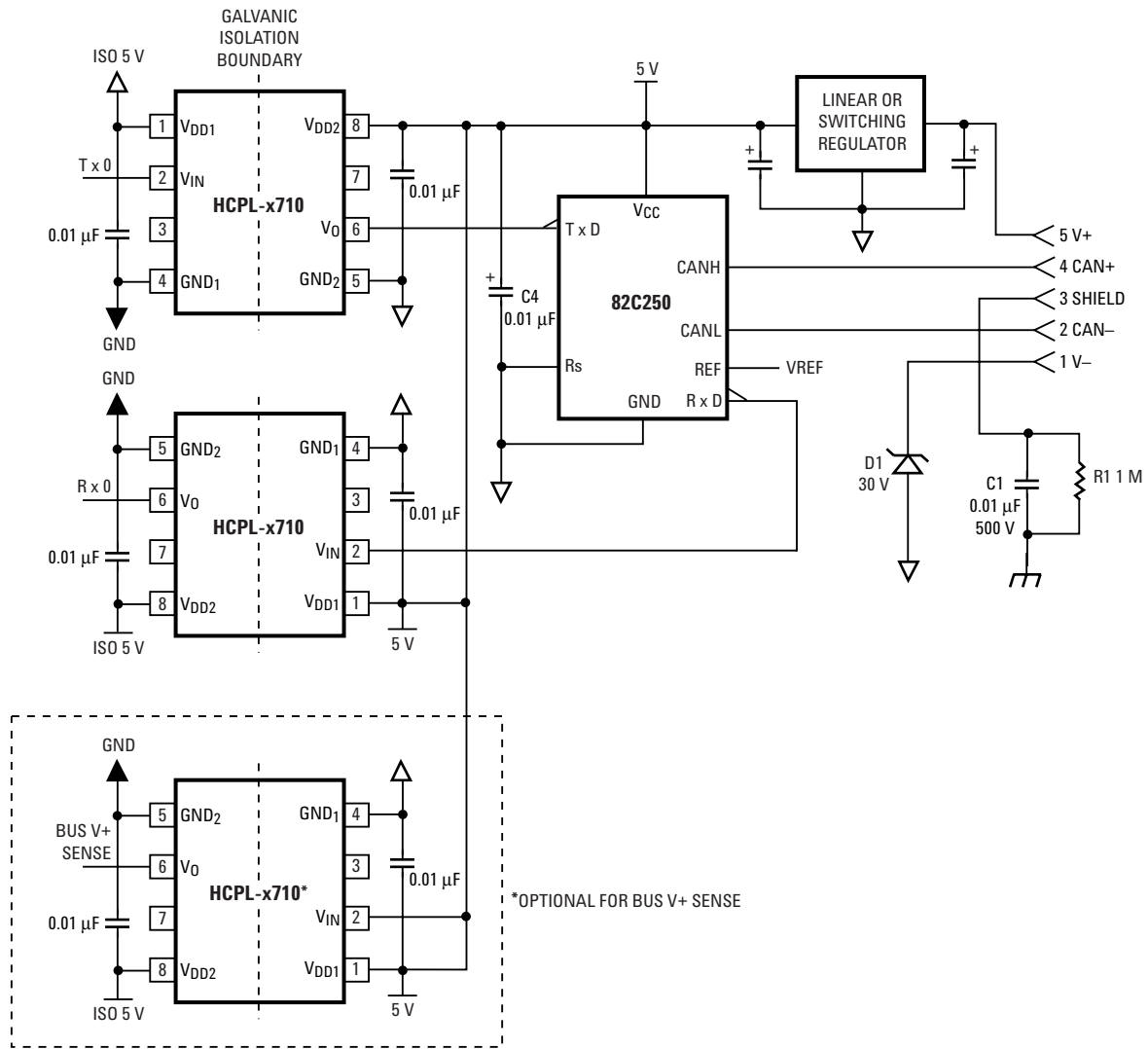

Figure 6. Recommended DeviceNet Application Circuit

state is ensured as the HCPL-x710/x72x output voltage (V_0) goes HIGH.

***Bus V+ Sensing**

It is suggested that the Bus V+ sense block shown in Figure 6 be implemented. A locally powered node with an unpowered isolated Physical Layer will accumulate errors and become bus-off if it attempts to transmit. The Bus V+ sense signal would be used to change the BOI attribute of the DeviceNet Object to the “auto-reset” (01) value. Refer to DeviceNet Specification Volume

1, Section 5.5.3. This would cause the node to continually reset until bus power was detected. Once power was detected, the BOI attribute would be returned to the “hold in bus-off” (00) value. The BOI attribute should not be left in the “auto-reset” (01) value since this defeats the jabber protection

capability of the CAN error confinement.

Recommended PROFIBUS Application Circuit

In PROFIBUS physical layer implementation, transmission technologies RS485 and IEC1158-2 are adopted by PROFIBUS. The recommended PROFIBUS application circuit is shown in Figure 7. Since the high-speed CMOS optocouplers HCPL-772x/072x are fully compatible with CMOS logic level signals, the optocouplers are connected

directly to the transceiver. Two bypass capacitors (with values between 0.01 and 0.1 μF) are required and should be located as close as possible to the input and output power-supply pins of the optocoupler. For each capacitor, the total lead length between both ends of the capacitor and the power supply pins should not exceed 20 mm. The bypass capacitors are required because of the high-speed digital nature of the signals inside the optocoupler.

Being very similar to multi-station RS485 systems, the HCPL-061N optocoupler provides a transmit disable function which is necessary to make the bus free after each master/slave transmission cycle. Specifically, the HCPL-061N disables the transmitter of the line driver by putting it into a high state mode. In addition, the HCPL-061N switches the RX/TX driver IC into the listen mode. The HCPL-061N offers HCMOS compatibility and the high CMR performance ($1 \text{ kV} / \mu\text{s}$ at $V_{\text{CM}} = 1000 \text{ V}$)

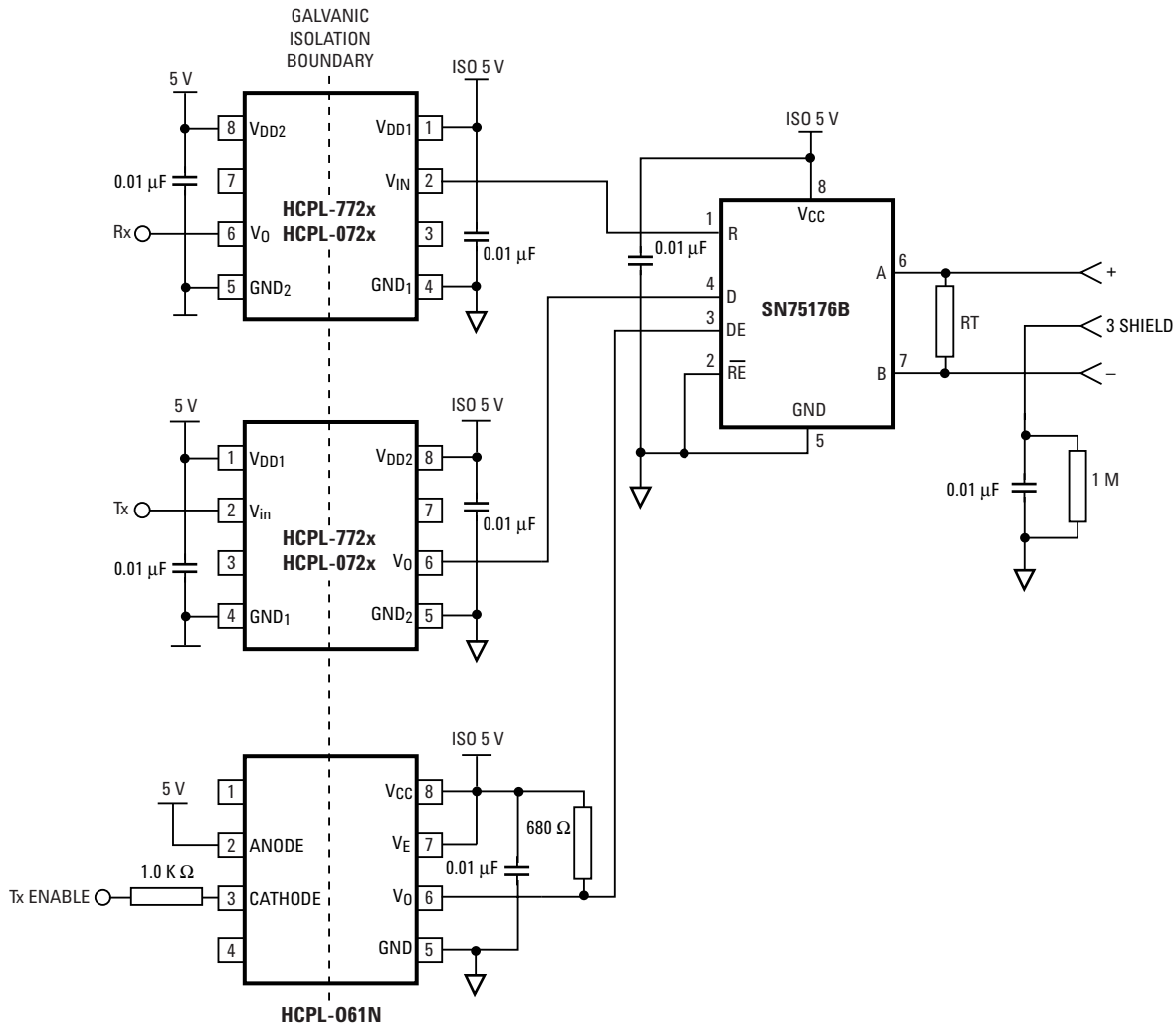

Figure 7. Recommended PROFIBUS Application Circuit

essential in industrial communication interfaces.

Recommended CC-Link Application Circuit

CC-Link (Control and Communication Link) is developed to merge control and information in the low-level network (field network) by PCs, thereby making the multivendor environment a reality. It has data control and message-exchange function, as well as bit control function, and operates at the

speed up to 10 Mbps.

The recommended CC-Link circuit is shown in Figure 8. Since the Agilent HCPL-772x/072x are fully compatible with CMOS logic level signals, the optocouplers are connected directly to the transceiver. Two bypass capacitors (with values between 0.01 μ F and 0.1 μ F) are required and should be located as close as possible to the input and output power supply pins of the HCPL-

772x/072x. For each capacitor, the total lead length between both ends of the capacitor and power supply pins should not exceed 20 mm. The bypass capacitors are required because of the high-speed digital nature of the signals inside the optocoupler. Two HCMOS-compatible and low cost optocouplers HCPL-2611 transmit Enable signals to the receiver and driver separately. Alternatively one dual-channel optocoupler HCPL-4661 or HCPL-0738 can be applied here to save cost and PCB size.

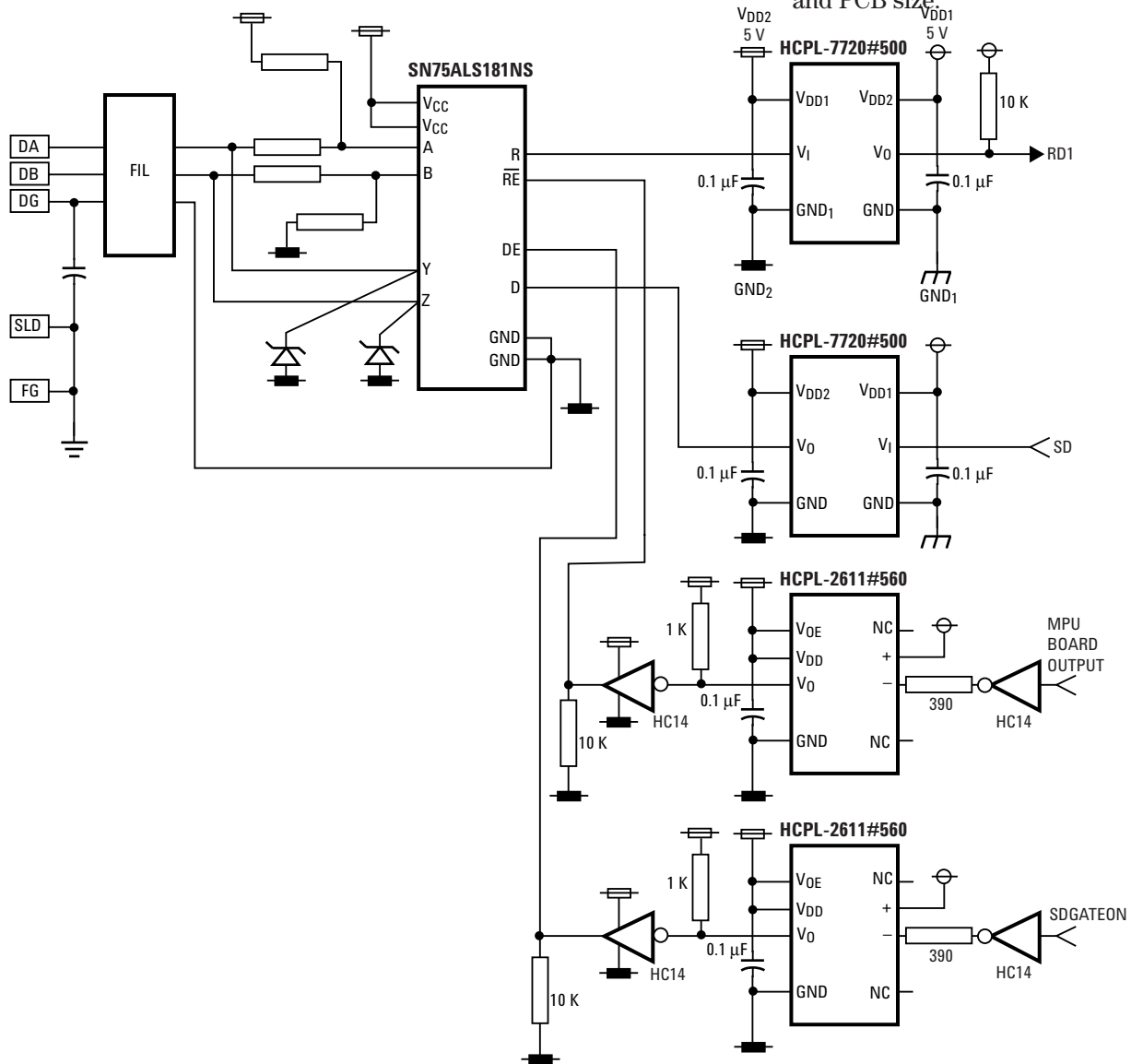

Figure 8. Recommended CC-Link Application Circuit

Appendix 1

Table 1. Popular Field Bus Specifications and Comparison

	CC-Link	DeviceNet	ProfiBus	CAN
Max. Devices or Nodes	64 per master	64	127 nodes (124 slaves -4 seg, 3 rptrs) + 3 masters	127
Max. Baud rate	156 Kbps to 10 Mbps depending upon distance	500 kBd	12 MBd (9.6 kBd to 12 MBd are supported)	1 Mbd
Max. Extension	1200 m (twisted pair), Master plus 10 repeaters = 13.2 Km	100 m at 500 kBd, 500m at 125 kBd, 6 km with repeaters	100 m between segments at 12 MBd, 24 km (Fiber) (baud rate and media dependent)	1 km at 10 kBd, 40 m at 1 MBd
Network Topology		Trunk line, drop line with branching	Line, Star, or Ring	Trunk line, drop line
Typical Applications	Commonly found in factory floor Processes	Most commonly found in assembly, welding, automotive, semiconductor, and material handling machines.	Commonly found in Process control and large assembly, and material handling machines	Commonly found in Automotive and Motion control systems, assembly, welding, and material handling machines
Technology Developer	Mitsubishi Electric	Layer 1, 2: Bosch AG, Layer 7: 1994 Rockwell Automation (Allen-Bradley)	Siemens Profibus DP (Decentral Periphery) 1994 Profibus PA (Process Automation) 1995	Layer 1, 2: Bosch AG, Layer 7: CAN In Automation, Philips, 1995

www.agilent.com/semiconductors

For product information and a complete list of distributors, please go to our web site.

For technical assistance call:

Americas/Canada: +1 (800) 235-0312 or
(916) 788-6763

Europe: +49 (0) 6441 92460

China: 10800 650 0017

Hong Kong: (+65) 6271 2451

India, Australia, New Zealand: (+65) 6271 2394

Japan: (+81 3) 3335-8152(Domestic/International), or
0120-61-1280(Domestic Only)

Korea: (+65) 6271 2194

Malaysia, Singapore: (+65) 6271 2054

Taiwan: (+65) 6271 2654

Data subject to change.

Copyright © 2003 Agilent Technologies, Inc.

Obsoletes 5988-8267EN

December 9, 2003

5989-0340EN



Agilent Technologies

SUNSTAR 商斯达实业集团是集研发、生产、工程、销售、代理经销、技术咨询、信息服务等为一体的高科技企业，是专业高科技电子产品生产厂家，是具有 10 多年历史的专业电子元器件供应商，是中国最早和最大的仓储式连锁规模经营大型综合电子零部件代理分销商之一，是一家专业代理和分销世界各大品牌 IC 芯片和电子元器件的连锁经营综合性国际公司，专业经营进口、国产名厂名牌电子元件，型号、种类齐全。在香港、北京、深圳、上海、西安、成都等全国主要电子市场设有直属分公司和产品展示展销窗口门市部专卖店及代理分销商，已在全国范围内建成强大统一的供货和代理分销网络。我们专业代理经销、开发生产电子元器件、集成电路、传感器、微波光电元器件、工控机/DOC/DOM 电子盘、专用电路、单片机开发、MCU/DSP/ARM/FPGA 软件硬件、二极管、三极管、模块等，是您可靠的一站式现货配套供应商、方案提供商、部件功能模块开发配套商。商斯达实业公司拥有庞大的资料库，有数位毕业于著名高校——有中国电子工业摇篮之称的西安电子科技大学（西军电）并长期从事国防尖端科技研究的高级工程师为您精挑细选、量身订做各种高科技电子元器件，并解决各种技术问题。

微波光电部专业代理经销高频、微波、光纤、光电元器件、组件、部件、模块、整机；电磁兼容元器件、材料、设备；微波 CAD、EDA 软件、开发测试仿真工具；微波、光纤仪器仪表。欢迎国外高科技微波、光纤厂商将优秀产品介绍到中国、共同开拓市场。长期大量现货专业批发高频、微波、卫星、光纤、电视、CATV 器件：晶振、VCO、连接器、PIN 开关、变容二极管、开关二极管、低噪晶体管、功率电阻及电容、放大器、功率管、MMIC、混频器、耦合器、功分器、振荡器、合成器、衰减器、滤波器、隔离器、环行器、移相器、调制解调器；光电子器件和组件：红外发射管、红外接收管、光电开关、光敏管、发光二极管和发光二极管组件、半导体激光二极管和激光器组件、光电探测器和光接收组件、光发射接收模块、光纤激光器和光放大器、光调制器、光开关、DWDM 用光发射和接收器件、用户接入系统光收发器件与模块、光纤连接器、光纤跳线/尾纤、光衰减器、光纤适配器、光隔离器、光耦合器、光环行器、光复用器/转换器；无线收发芯片和模组、蓝牙芯片和模组。

更多产品请看本公司产品专用销售网站：

商斯达微波光电产品网：[HTTP://www.rfoe.net/](http://www.rfoe.net/)

商斯达中国传感器科技信息网：<http://www.sensor-ic.com/>

商斯达工控安防网：<http://www.pc-ps.net/>

商斯达电子元器件网：<http://www.sunstare.com/>

商斯达消费电子产品网：<http://www.icasic.com/>

商斯达实业科技产品网：<http://www.sunstars.cn/> 射频微波光电元器件销售热线：

地址：深圳市福田区福华路福庆街鸿图大厦 1602 室

电话：0755-83396822 83397033 83398585 82884100

传真：0755-83376182 (0) 13823648918 MSN: SUNS8888@hotmail.com

邮编：518033 E-mail:szss20@163.com QQ: 195847376

深圳赛格展销部：深圳华强北路赛格电子市场 2583 号 电话：0755-83665529 25059422

技术支持：0755-83394033 13501568376

欢迎索取免费详细资料、设计指南和光盘；产品凡多，未能尽录，欢迎来电查询。

北京分公司：北京海淀区知春路 132 号中发电子大厦 3097 号

TEL: 010-81159046 82615020 13501189838 FAX: 010-62543996

上海分公司：上海市北京东路 668 号上海赛格电子市场 D125 号

TEL: 021-28311762 56703037 13701955389 FAX: 021-56703037

西安分公司：西安高新开发区 20 所(中国电子科技集团导航技术研究所)

西安劳动南路 88 号电子商城二楼 D23 号

TEL: 029-81022619 13072977981 FAX:029-88789382