



## Product Description

The Sirenza Microdevices' STQ-2016 is a direct quadrature modulator targeted for use in a wide range of communications systems, including cellular/PCS, CDMA2000, UMTS, and ISM datacom. This device features a wide 700-2500 MHz operating frequency band, excellent carrier and sideband suppression, and a low broadband noise floor.

The STQ-2016 uses silicon germanium (SiGe) device technology and delivers a typical output power of -11dBm with greater than 60dB IM3 suppression. A digital input shut-down feature is included that, when enabled, attenuates the output by 60dB. The device is packaged in an industry standard 16 pin TSSOP with exposed paddle for superb RF and thermal ground. The STQ-2016Z is packaged in a RoHS compliant and Green 16-pin TSSOP with matte tin finish.

**Functional Block Diagram**

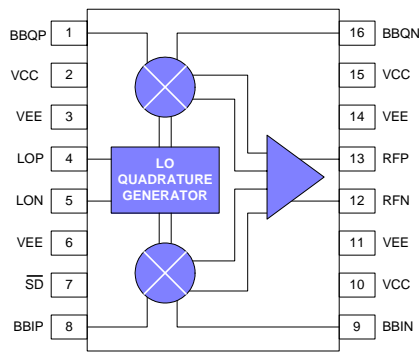

## Product Specifications – RF Output: $T_A = 25^\circ\text{C}$

Parameters	Test Conditions (see page 2)	Units	Min.	Typ.	Max.	Min.	Typ.	Max.
RF Frequency Range		MHz	700		1000	1700		2500
Output Power	baseband 200kHz @ 600mVp-p differential	dBm	-13.0	-10.5	-9.0	-15.0	-11.5	-9.0
RF Port Return Loss	matched to $50\Omega$ (refer to schematics on pages 6 & 7)	dB		20			16	
Output P1dB	(I/Q inputs = 3.74 Vp-p differential typical)	dBm	+3	+4		0	+3	
Carrier Feedthrough		dBm		-40	-34		-40	-32
Sideband Suppression		dB	34	40		34	40	
IM3 Suppression	two-tone baseband input @ 600mVp-p differential per tone	dB	58	62		58	65	
Broadband Noise Floor	baseband inputs tied to $1.9V_{DC}$ , -20MHz offset from carrier	dBm/Hz		-154	-152		-155	-153
Quadrature Phase Error		deg	-2	$\pm 0.5$	+2	-2	$\pm 0.5$	+2
I/Q Amplitude Balance		dB	-0.2	$\pm 0.05$	+0.2	-0.2	$\pm 0.05$	+0.2
Supply Voltage (Vcc)		V	+4.75	+5	+5.25	+4.75	+5	+5.25
Supply Current		mA		73	86		73	86
Device Thermal Resistance	junction-case	$^\circ\text{C/W}$		25			25	

The information provided herein is believed to be reliable at press time. Sirenza Microdevices assumes no responsibility for inaccuracies or omissions. Sirenza Microdevices assumes no responsibility for the use of this information, and all such information shall be entirely at the user's own risk. Prices and specifications are subject to change without notice. No patent rights or licenses to any of the circuits described herein are implied or granted to any third party. Sirenza Microdevices does not authorize or warrant any Sirenza Microdevices product for use in life-support devices and/or systems.

Copyright 2001 Sirenza Microdevices, Inc. All worldwide rights reserved.  
303 South Technology Court Broomfield, CO 80021

Phone: (800) SMI-MMIC

1

<http://www.sirenza.com>  
EDS-102083 Rev F

## STQ-2016

## STQ-2016Z



### 700-2500 MHz Direct Quadrature Modulator

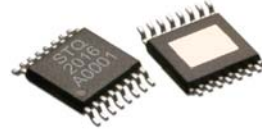

#### 16 pin TSSOP with Exposed Ground Pad

Package Footprint: 0.197 x 0.252 inches, (5.0 x 6.4 mm)  
Package Height: 0.039 inches (1.0 mm)

## Product Features

- Excellent carrier feedthrough, -40 dBm constant with output power
- Output P1dB +3dBm
- Wide baseband input, DC - 500 MHz
- Superb phase accuracy and amplitude balance,  $\pm 0.5$  deg./ $\pm 0.2$  dB
- Very low noise floor, -155 dBm/Hz
- Low LO drive requirement, -5 dBm

## Applications

- Cellular/PCS/CDMA2000/UMTS transceivers
- ISM band transceivers, 900 & 2400 MHz
- GMSK, QPSK, QAM, SSB modulators



**STQ-2016 Direct Quadrature Modulator**

**Test Conditions**

(for all product specification tables unless otherwise noted)

V <sub>CC</sub> (pins 2,10,15)	+5V
T <sub>A</sub>	+25°C
Baseband Input (Pins 1, 8, 9, 16)	1.9V DC bias, 200kHz frequency, 300mVp-p per pin = 600mVp-p differential drive, I and Q signals in quadrature
LO Input (Pins 4, 5)	-5dBm @ 1960 MHz

**Product Specifications - Baseband Modulation Input: T<sub>A</sub> = 25°C**

Parameters	Additional Test Conditions	Unit	Min.	Typ.	Max.
Baseband Frequency Input	-3dB bandwidth, baseband inputs terminated in 50 ohms	MHz	DC		500
Baseband Input Resistance	per pin	kohms		4.4	
Baseband Input Capacitance	per pin	pF		0.5	

**Product Specifications - LO Input: T<sub>A</sub> = 25°C**

Parameters	Additional Test Conditions	Unit	Min.	Typ.	Max.
LO Frequency		MHz	700		2500
LO Drive Level		dBm	-8	-5	-2
LO Port Return Loss	matched to 50Ω (refer to schematics on pages 6 & 7)	dB		16	

**Product Specifications – Miscellaneous: T<sub>A</sub> = 25°C**

Parameters	Additional Test Conditions	Unit	Min.	Typ.	Max.
Shut-Down Attenuation		dB		60	
Shut-Down Pin Resistance	@ 1MHz	kohm		11.9	
Shut-Down Pin Capacitance	@ 1MHz	pF		5.2	
Shut-down Control Voltage Thresholds	Shut-down disabled (normal operation)	V	3.75		V <sub>CC</sub>
	Shut-down enabled	V	0.0		1.5
Shut-Down Settling Time		ns		<450	

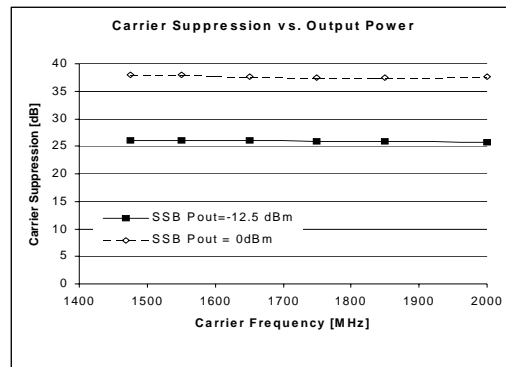



**STQ-2016 Direct Quadrature Modulator**

**700 - 1000 MHz Typical Device Performance**

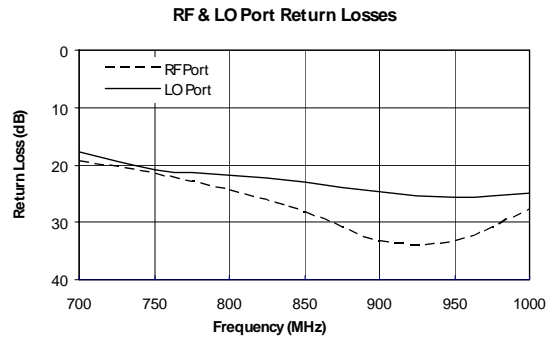
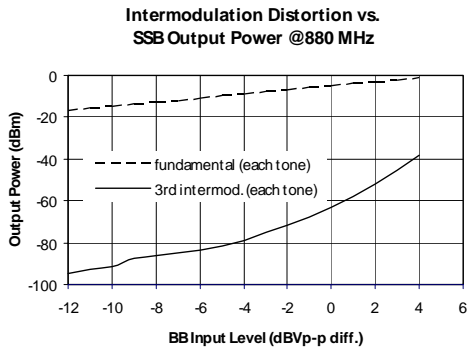
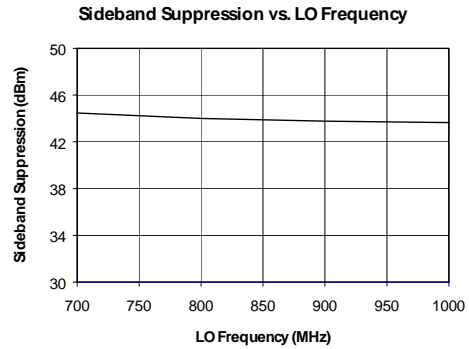
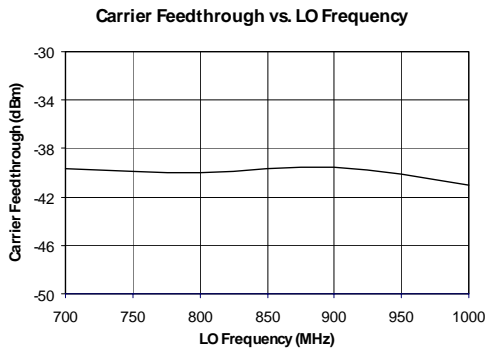
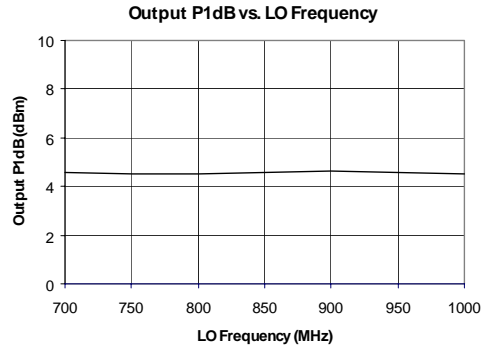
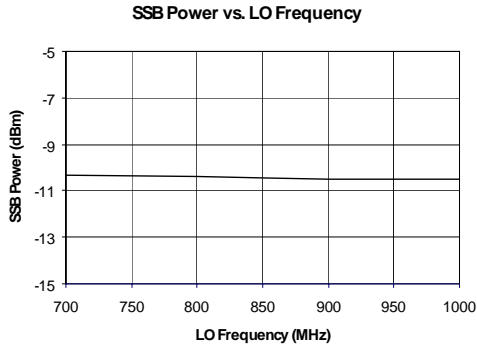



STQ-2016 Direct Quadrature Modulator

1500 - 2500 MHz Typical Device Performance

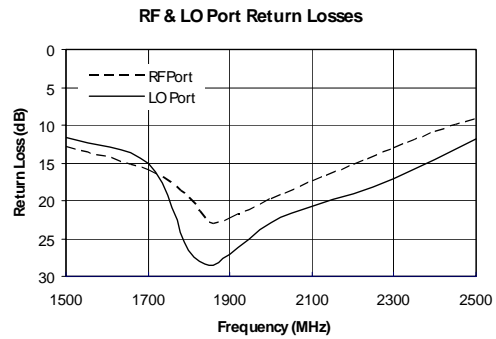
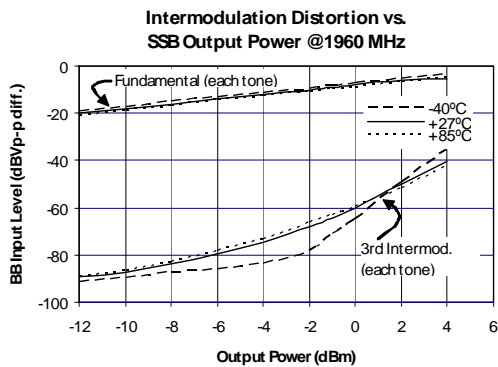
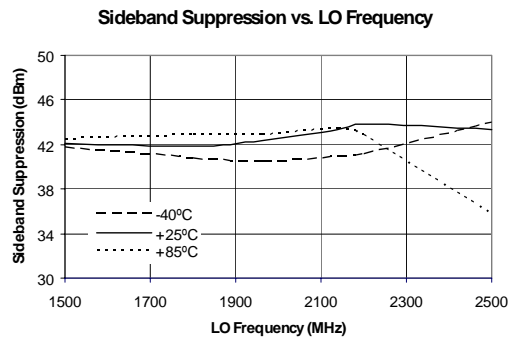
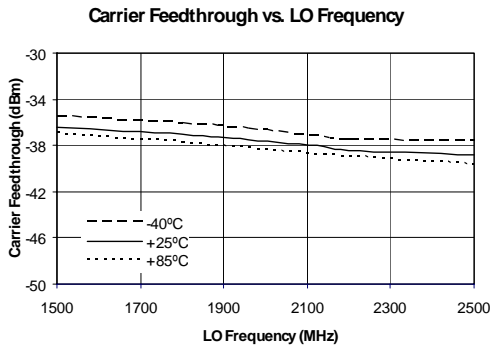
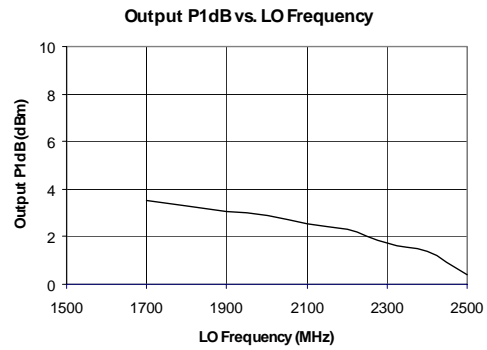
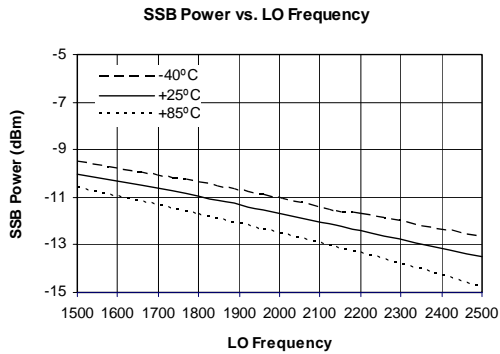



## STQ-2016 Direct Quadrature Modulator

### Package Dimensions ("16" Package)

Dimensions in inches (mm)

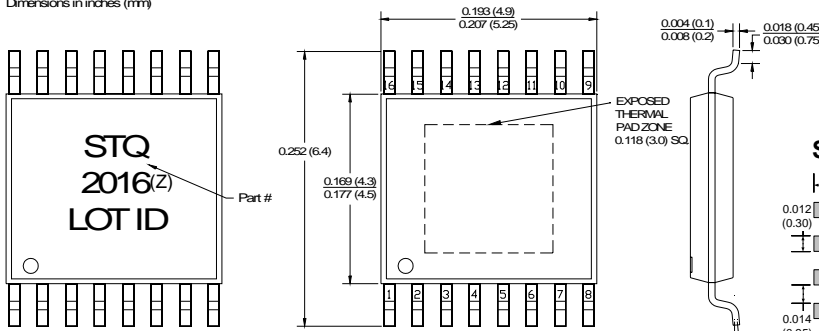

**NOTES:**

1. PACKAGE BODY SIZES EXCLUDE MOLD FLASH PROTRUSIONS OR GATE BURRS.
2. TOLERANCE  $\pm 0.1$ MM UNLESS OTHERWISE SPECIFIED.
3. COPLANARITY: 0.1MM
4. CONTROLLING DIMENSION IS MILLIMETER, CONVERTED INCH DIMENSIONS ARE NOT NECESSARILY EXACT.
5. FOLLOWED FROM JEDEC MO-153.

### Pin Out Description

Pin #	Function	Description	Additional Comments
1	BBQP	Q-channel baseband input, positive terminal	Nominal DC bias voltage is 1.9V (biased internally)
2	VCC	Positive supply (+5V)	
3	VEE	Ground	
4	LOP	Local oscillator input, positive terminal	Nominal DC voltage is 2.0V. Input should be AC-coupled.
5	LON	Local oscillator input, negative terminal	Nominal DC voltage is 2.0V. Input should be AC-coupled.
6	VEE	Ground	
7	SD	Shut-down control	Logic high = normal operation; logic low = shut-down enabled.
8	BBIP	I-channel baseband input, positive terminal	Nominal DC bias voltage is 1.9V (biased internally)
9	BBIN	I-channel baseband input, negative terminal	Nominal DC bias voltage is 1.9V (biased internally)
10	VCC	Positive supply (+5V)	
11	VEE	Ground	
12	RFN	RF output, negative terminal	Nominal DC voltage is 2.4V. Output should be AC-coupled.
13	RFP	RF output, positive terminal	Nominal DC voltage is 2.4V. Output should be AC-coupled.
14	VEE	Ground	
15	VCC	Positive supply (+5V)	
16	BBQN	Q-channel baseband input, negative terminal	Nominal DC bias voltage is 1.9V (biased internally)

### Suggested PCB Pad Layout

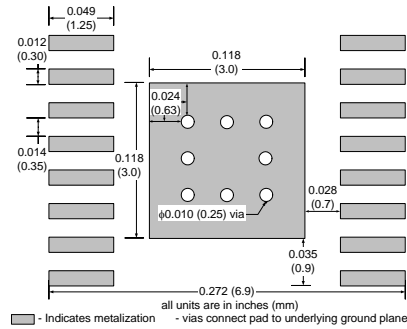

### Absolute Maximum Ratings

Parameters	Value	Unit
Supply Voltage (VCC)	6.0	V <sub>DC</sub>
LO, RF Input (LOP, LON, RFP, RFN)	+10	dBm
Baseband Min Input Voltage (BBIP, BBIN, BBQP, BBQN)	0	V <sub>DC</sub>
Baseband Max Input Voltage (BBIP, BBIN, BBQP, BBQN)	3	V <sub>DC</sub>
Operating Temperature	-40 to +85	°C
Storage Temperature	-65 to +150	°C

Operation of this device beyond any one of these limits may cause permanent damage. For reliable continuous operation the device voltage and current must not exceed the maximum operating values specified in the table on page one.

### Part Number Ordering Information

Part Number	Reel Size	Devices/Reel
STQ-2016	7"	1000
STQ-2016Z	7"	1000



### Caution: ESD Sensitive

Appropriate precaution in handling, packaging and testing devices must be observed.



**STQ-2016 Direct Quadrature Modulator**

**700 – 1000 MHz Application Schematic**

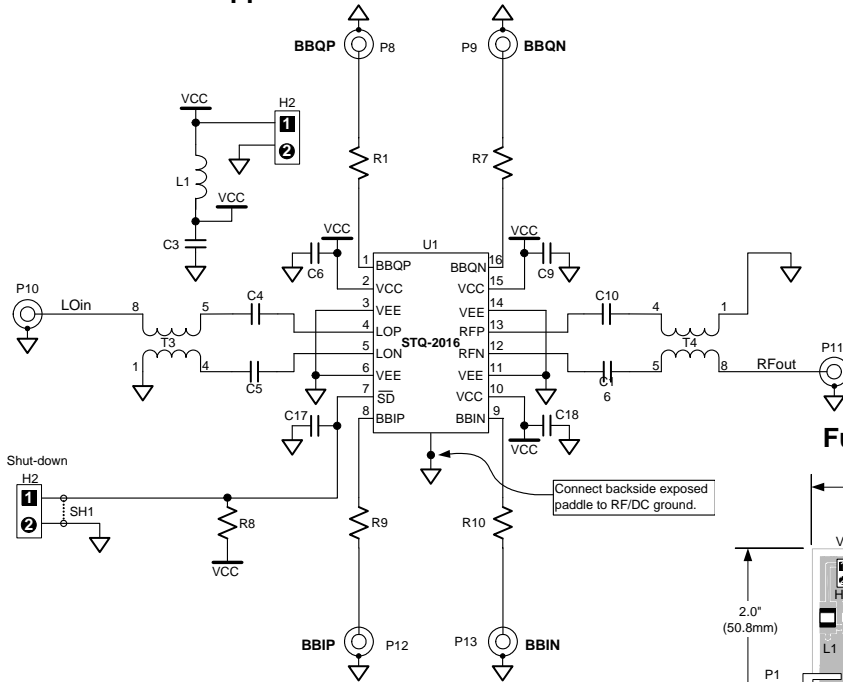

**Fully Assembled PCB**

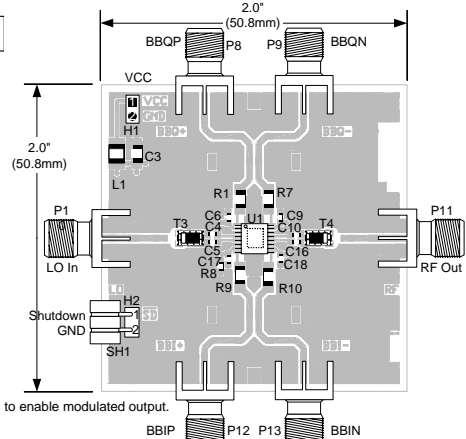

**Bill of Materials (for 700 – 1000 MHz Evaluation Board P/N STQ-2016EVB-1)**

Component Designator	Value	Qty	Vendor	Part Number	Description
U1		1	SMDI	STQ-2016	SiGe Direct Quadrature Modulator
P8, P9, P10, P11, P12, P13		6	Johnson Components	142-0701-851	SMA connector, end launch with tab, for .062" thick board
H1, H2		2	AMP	640453-2	2-pin header, right angle
T3, T4	1:1	2	Panasonic	EHF-FD1618	RF transformer, 700-1300MHz
L1	1uH	1	Panasonic	ELJ-FA1R0KF2	Inductor, 1210 footprint, ±10% tolerance
R1, R7, R9, R10	200 ohm	4	Venkel	CR1206-8W-2000T	Resistor, 1206 footprint, ±1% tolerance
R8	1 kohm	1	Venkel	CR0603-16W-1001FT	Resistor, 0603 footprint, ±1% tolerance
C6, C18	33pF	2	Venkel	C0603COG500-330JNE	Capacitor, 0603 footprint, COG dielectric, ±5% tolerance
C9, C17	1nF	2	Venkel	C0603COG500-102JNE	Capacitor, 0603 footprint, COG dielectric, ±5% tolerance
C3	2.2uF	1	Venkel	C1206Y5V160-225ZNE	Capacitor, 1206 footprint, Y5V dielectric, 16V rating
C4, C5, C10, C16	10pF	4	Venkel	C0603COG500-100JNE	Capacitor, 0603 footprint, COG dielectric, ±5% tolerance
SH1		1	3M	929950-00	Shunt for 2-pin header



**STQ-2016 Direct Quadrature Modulator**

**1.7 – 2.5 GHz Application Schematic**

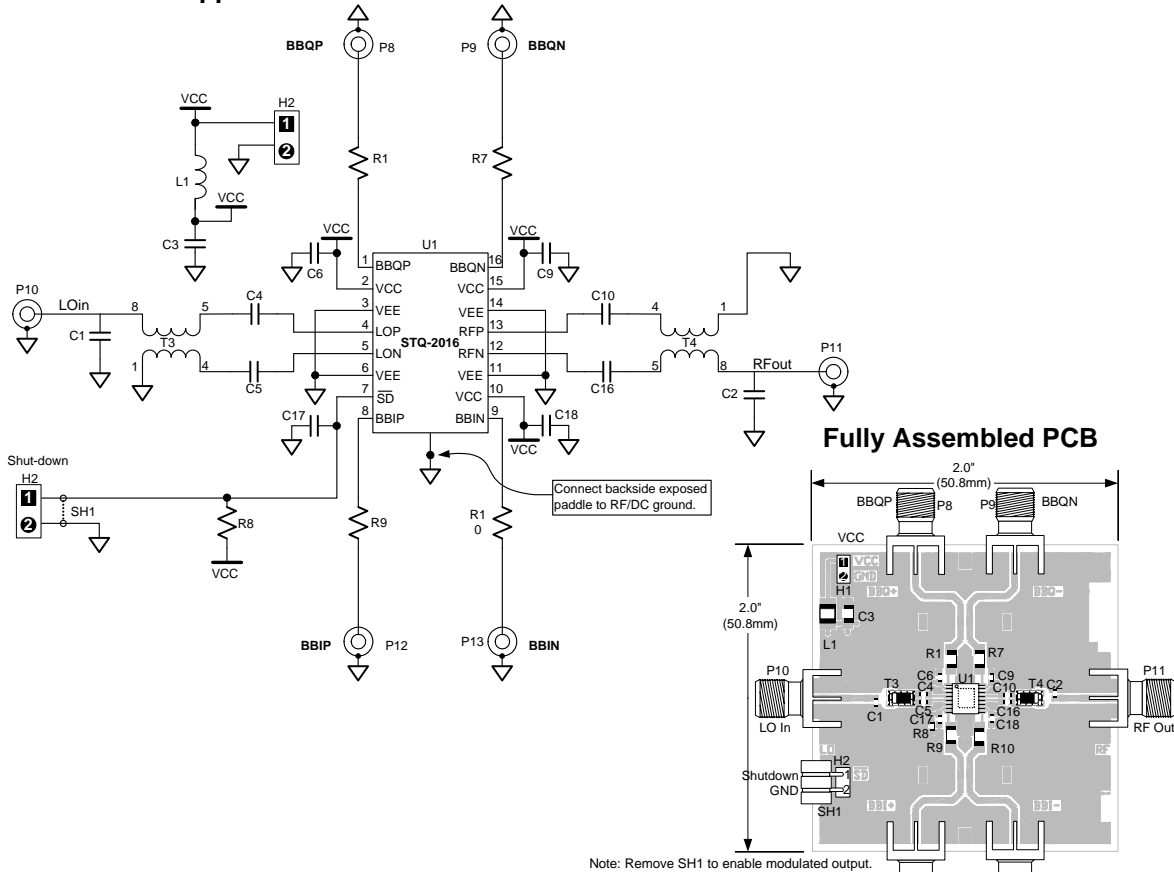

Note: Remove SH1 to enable modulated output.

**Bill of Materials (for 1.7 – 2.5 GHz Evaluation Board P/N STQ-2016EV2)**

Component Designator	Value	Qty	Vendor	Part Number	Description
U1		1	SMDI	STQ-2016	SiGe Direct Quadrature Modulator
P8, P9, P10, P11, P12, P13		6	Johnson Components	142-0701-851	SMA connector, end launch with tab, for .062" thick board
H1, H2		2	AMP	640453-2	2-pin header, right angle
T3, T4	1:1	2	Panasonic	EHF-FD1619	RF transformer, 1200-2200MHz
L1	1uH	1	Panasonic	ELJ-FA1R0KF2	Inductor, 1210 footprint, ±10% tolerance
R1, R7, R9, R10	200 ohm	4	Venkel	CR1206-8W-2000T	Resistor, 1206 footprint, ±1% tolerance
R8	1 kohm	1	Venkel	CR0603-16W-1001FT	Resistor, 0603 footprint, ±1% tolerance
C1, C2	0.5pF	2	Venkel	C0603COG500-0R5CNE	Capacitor, 0603 footprint ±0.25pF tolerance
C6, C18	6.8pF	2	Venkel	C0603COG500-6R8CNE	Capacitor, 0603 footprint, COG dielectric, ±0.25pF tol.
C9, C17	1nF	2	Venkel	C0603COG500-102JNE	Capacitor, 0603 footprint, COG dielectric, ±5% tolerance
C3	2.2uF	1	Venkel	C1206Y5V160-225ZNE	Capacitor, 1206 footprint, Y5V dielectric, 16V rating
C4, C5, C10, C16	2.2pF	4	Venkel	C0603COG500-2R2CNE	Capacitor, 0603 footprint, COG dielectric, ±0.25pF tolerance
SH1		1	3M	929950-00	Shunt for 2-pin header

303 South Technology Court Broomfield, CO 80021

Phone: (800) SMI-MMIC

<http://www.sirenza.com>

EDS-102083 Rev F



## STQ-2016 Direct Quadrature Modulator

### Direct Quadrature Modulator: General Test Set-Up

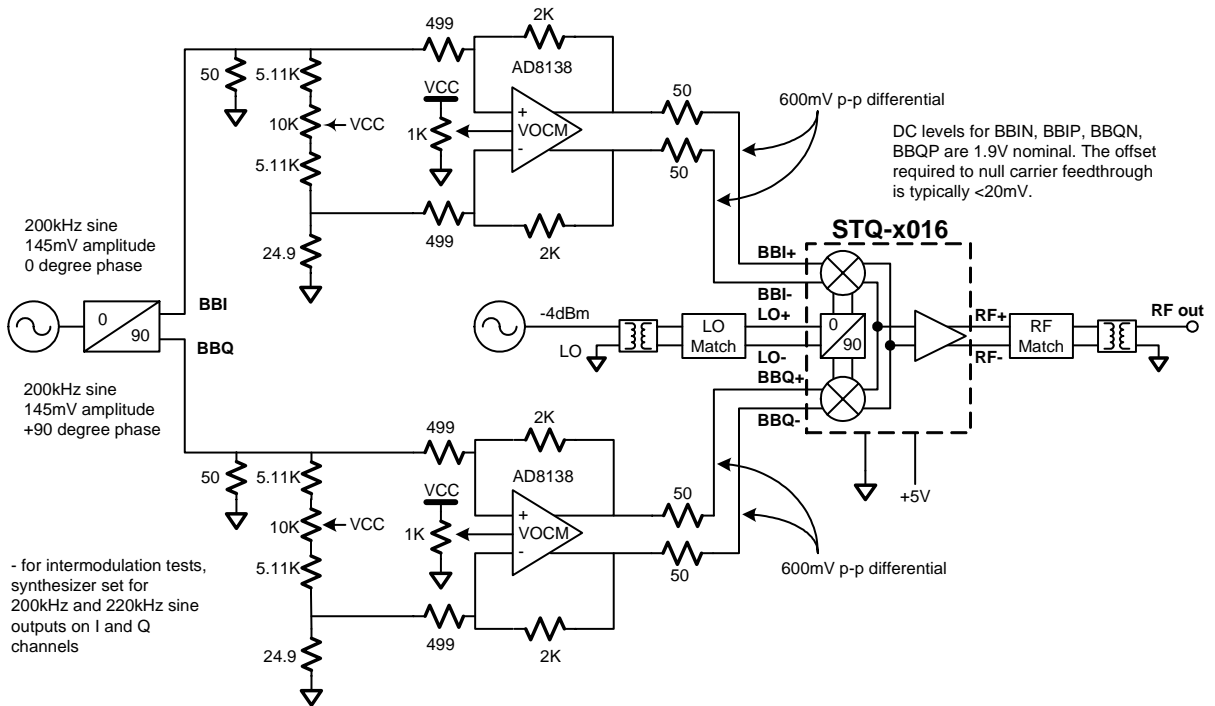



SUNSTAR 商斯达实业集团是集研发、生产、工程、销售、代理经销、技术咨询、信息服务等为一体的高科技企业，是专业高科技电子产品生产厂家，是具有 10 多年历史的专业电子元器件供应商，是中国最早和最大的仓储式连锁规模经营大型综合电子零部件代理分销商之一，是一家专业代理和分销世界各大品牌 IC 芯片和电子元器件的连锁经营综合性国际公司，专业经营进口、国产名厂名牌电子元件，型号、种类齐全。在香港、北京、深圳、上海、西安、成都等全国主要电子市场设有直属分公司和产品展示展销窗口门市部专卖店及代理分销商，已在全国范围内建成强大统一的供货和代理分销网络。我们专业代理经销、开发生产电子元器件、集成电路、传感器、微波光电元器件、工控机/DOC/DOM 电子盘、专用电路、单片机开发、MCU/DSP/ARM/FPGA 软件硬件、二极管、三极管、模块等，是您可靠的一站式现货配套供应商、方案提供商、部件功能模块开发配套商。商斯达实业公司拥有庞大的资料库，有数位毕业于著名高校——有中国电子工业摇篮之称的西安电子科技大学（西军电）并长期从事国防尖端科技研究的高级工程师为您精挑细选、量身订做各种高科技电子元器件，并解决各种技术问题。

微波光电部专业代理经销高频、微波、光纤、光电元器件、组件、部件、模块、整机；电磁兼容元器件、材料、设备；微波 CAD、EDA 软件、开发测试仿真工具；微波、光纤仪器仪表。欢迎国外高科技微波、光纤厂商将优秀产品介绍到中国、共同开拓市场。长期大量现货专业批发高频、微波、卫星、光纤、电视、CATV 器件：晶振、VCO、连接器、PIN 开关、变容二极管、开关二极管、低噪晶体管、功率电阻及电容、放大器、功率管、MMIC、混频器、耦合器、功分器、振荡器、合成器、衰减器、滤波器、隔离器、环行器、移相器、调制解调器；光电子元件和组件：红外发射管、红外接收管、光电开关、光敏管、发光二极管和发光二极管组件、半导体激光二极管和激光器组件、光电探测器和光接收组件、光发射接收模块、光纤激光器和光放大器、光调制器、光开关、DWDM 用光发射和接收器件、用户接入系统光收发器件与模块、光纤连接器、光纤跳线/尾纤、光衰减器、光纤适配器、光隔离器、光耦合器、光环行器、光复用器/转换器；无线收发芯片和模组、蓝牙芯片和模组。

更多产品请看本公司产品专用销售网站：

商斯达中国传感器科技信息网：<http://www.sensor-ic.com/>

商斯达工控安防网：<http://www.pc-ps.net/>

商斯达电子元器件网：<http://www.sunstare.com/>

商斯达微波光电产品网：[HTTP://www.rfoe.net/](http://www.rfoe.net/)

商斯达消费电子产品网：<http://www.icasic.com/>

商斯达实业科技产品网：<http://www.sunstars.cn/> 微波元器件销售热线：

地址：深圳市福田区福华路福庆街鸿图大厦 1602 室

电话：0755-82884100 83397033 83396822 83398585

传真：0755-83376182 (0) 13823648918 MSN: SUNS8888@hotmail.com

邮编：518033 E-mail:szss20@163.com QQ: 195847376

深圳赛格展销部：深圳华强北路赛格电子市场 2583 号 电话：0755-83665529 25059422

技术支持：0755-83394033 13501568376

欢迎索取免费详细资料、设计指南和光盘；产品凡多，未能尽录，欢迎来电查询。

北京分公司：北京海淀区知春路 132 号中发电子大厦 3097 号

TEL: 010-81159046 82615020 13501189838 FAX: 010-62543996

上海分公司：上海市北京东路 668 号上海赛格电子市场 D125 号

TEL: 021-28311762 56703037 13701955389 FAX: 021-56703037

西安分公司：西安高新开发区 20 所(中国电子科技集团导航技术研究所)

西安劳动南路 88 号电子商城二楼 D23 号

TEL: 029-81022619 13072977981 FAX:029-88789382