



Product Description

Sirenza Microdevices' SXA-3318B amplifier is a high efficiency GaAs Heterojunction Bipolar Transistor (HBT) MMIC housed in a low-cost surface-mountable plastic package. These HBT MMICs are fabricated using molecular beam epitaxial growth technology which produces reliable and consistent performance from wafer to wafer and lot to lot.

These amplifiers are specially designed for use as driver devices for infrastructure equipment in the 400-2500 MHz cellular, ISM, WLL, PCS, W-CDMA applications.

Its high linearity makes it an ideal choice for multi-carrier as well as digital applications.

The matte tin finish on Sirenza's lead-free package utilizes a post annealing process to mitigate tin whisker formation and is RoHS compliant per EU Directive 2002/95. This package is also manufactured with green molding compounds that contain no antimony trioxide nor halogenated fire retardants.

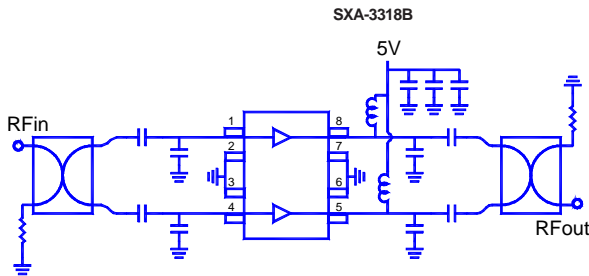

SXA-3318B

SXA-3318BZ



400-2500 MHz

Balanced 1/2 W Medium Power

GaAs HBT Amplifier with Active Bias



Product Features

- Now available in Lead Free, RoHS Compliant, & Green Packaging
- On-chip Active Bias Control
- Balanced for excellent input/output VSWR and minimized reflections
- High OIP₃ : +47 dBm typ.
- High P_{1dB} : +28 dBm typ.
- Patented High Reliability GaAs HBT Technology
- Surface-Mountable Power Plastic Package

Applications

- W-CDMA, PCS, Cellular Systems
- High Linearity IF Amplifiers
- Multi-Carrier Applications

Symbol	Parameters: Test Conditions: Z ₀ = 50 Ohms, Ta = 25°C, Measured in Evaluation Circuit		Units	Min.	Typ.	Max.
P _{1dB}	Output Power at 1dB Compression	f = 850 MHz f = 1960 MHz f = 2140 MHz	dBm	27.0	27.5 28.0 28.0	
S ₂₁	Small signal gain	f = 850 MHz f = 1960 MHz f = 2140 MHz	dB	10.5	16.0 17.5 12.8 12.0	19.0 13.5
VSWR _{in}	Input VSWR	f = 850 MHz f = 1960 MHz f = 2140 MHz	-		1.3 1.2 1.2	1.7
OIP ₃	Output Third Order Intercept Point (P _{out} /Tone = +11 dBm, Tone spacing = 1 MHz)	f = 850 MHz f = 1960 MHz f = 2140 MHz	dBm	44	44 47 47	
ACP	Adjacent Channel Power: IS-95 at P _{OUT} = 19 dBm IS-95 at P _{OUT} = 19 dBm W-CDMA at P _{OUT} = 18 dBm	f = 880 MHz f = 1960 MHz f = 2140 MHz	dBc		-55 -55 -50	
NF	Noise Figure	f = 850 MHz f = 1960 MHz f = 2140 MHz	dB		4.5 5.1 5.1	6.0
I _b	Device Current (120 mA per amplifier)	V _{cc} = 5V	mA	180	240	280
R _{th(j-l)}	Thermal Resistance (junction - lead) per amplifier *Note: 2 amplifiers per packaged part		° C/W		70	

The information provided herein is believed to be reliable at press time. Sirenza Microdevices assumes no responsibility for inaccuracies or omissions. Sirenza Microdevices assumes no responsibility for the use of this information, and all such information shall be entirely at the user's own risk. Prices and specifications are subject to change without notice. No patent rights or licenses to any of the circuits described herein are implied or granted to any third party. Sirenza Microdevices does not authorize or warrant any Sirenza Microdevices product for use in life-support devices and/or systems.

Copyright 2003 Sirenza Microdevices, Inc. All worldwide rights reserved.

303 South Technology Ct., Broomfield, CO 80021

Phone: (800) SMI-MMIC

1

<http://www.sirenza.com>

EDS-103164 Rev B



850 MHz Application Circuit Data, $V_{CC} = 5V, I_D = 240mA$

Note: Tested in Balanced Configuration shown in Application Circuit, tuned for Output IP3

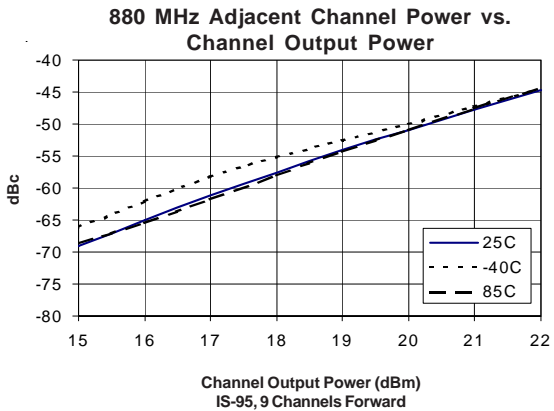
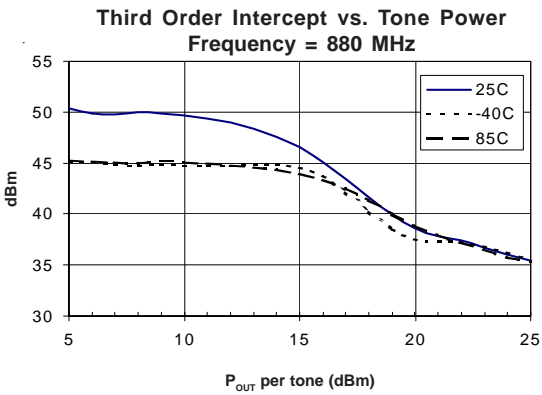
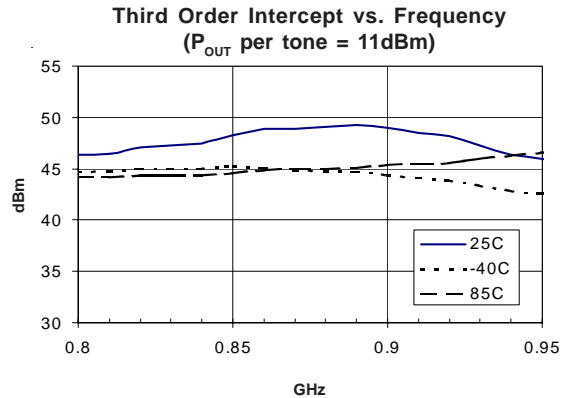
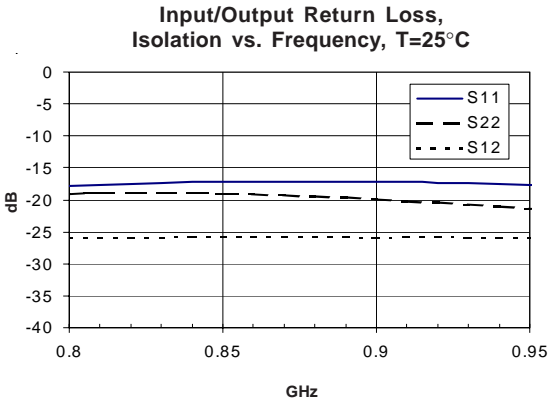
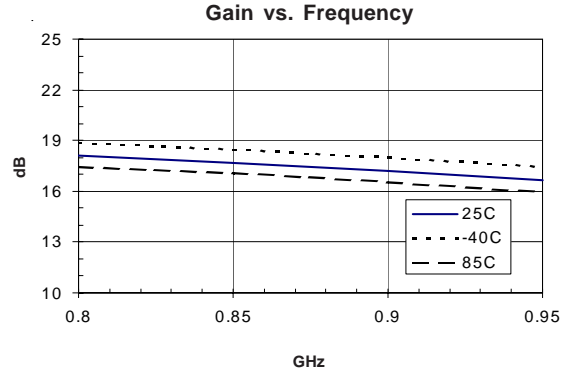
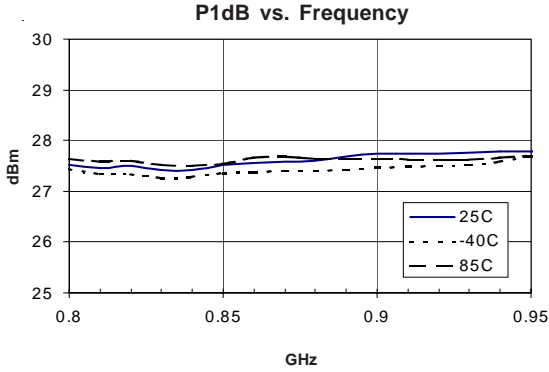



1960 MHz Application Circuit Data, $V_{CC} = 5V, I_D = 240mA$

Note: Tested in Balanced Configuration shown in Application Circuit, tuned for Output IP3

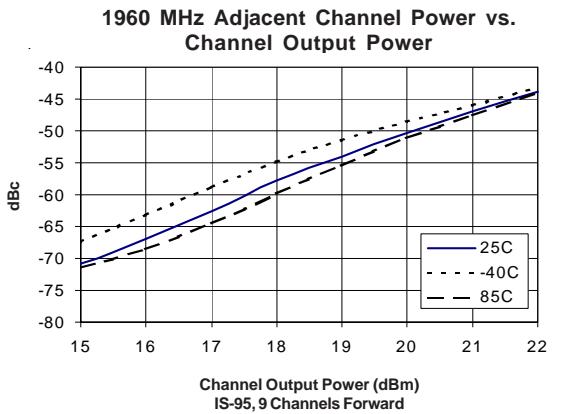
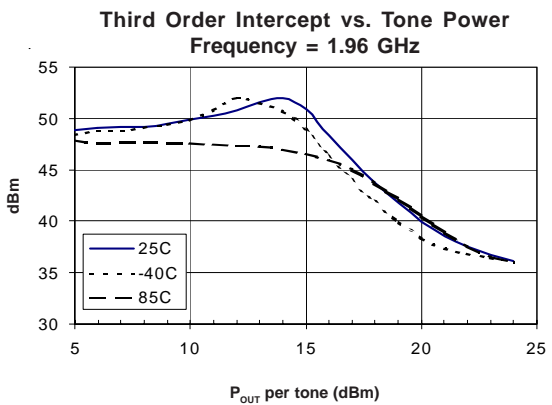
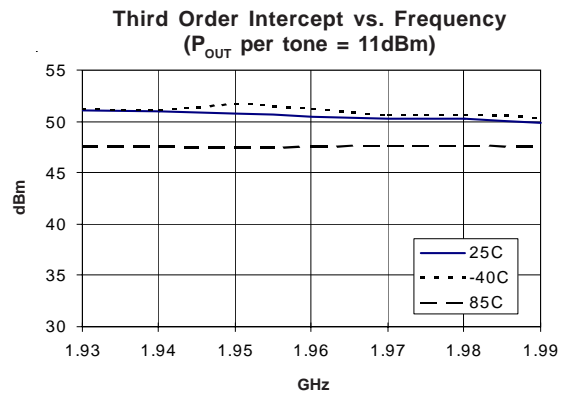
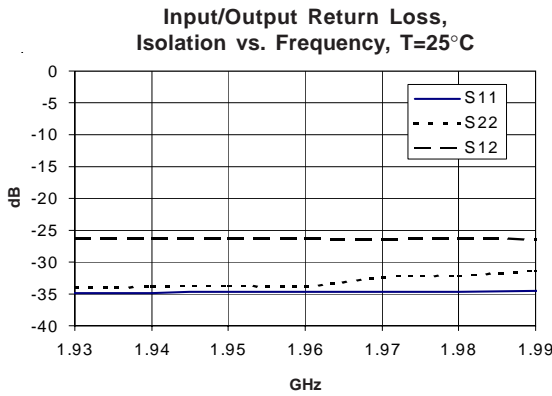
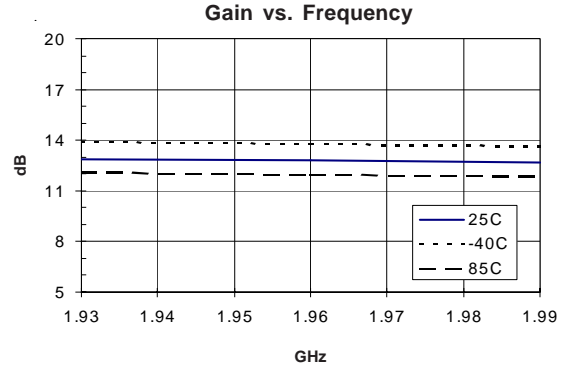
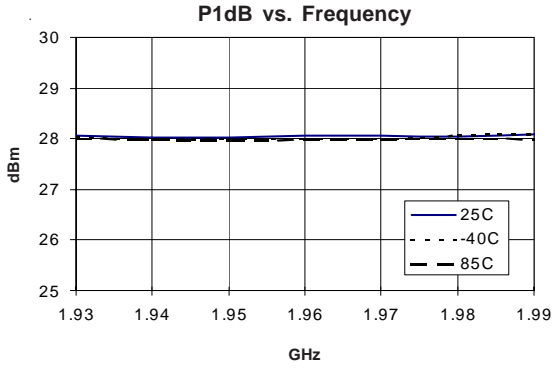



2140 MHz Application Circuit Data, $V_{CC} = 5V$, $I_D = 240mA$

Note: Tested in Balanced Configuration shown in Application Circuit, tuned for Output IP3

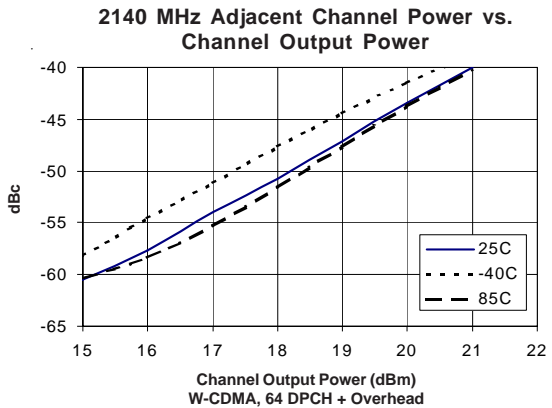
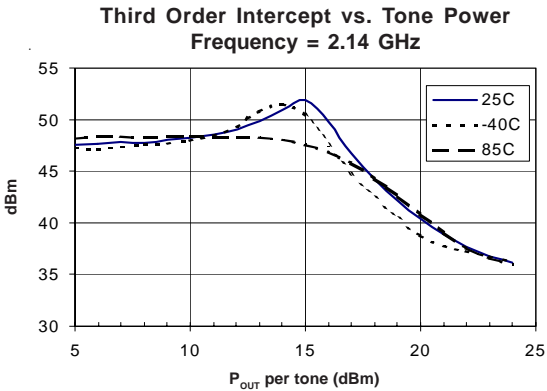
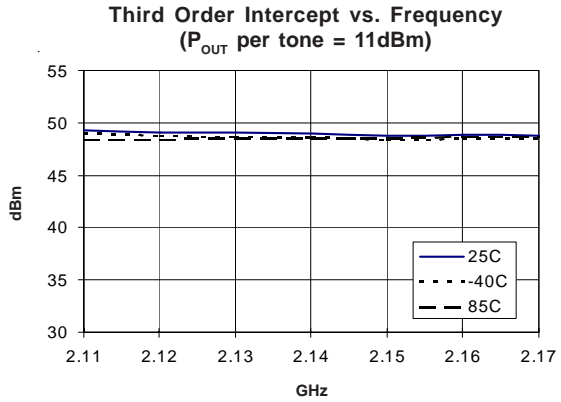
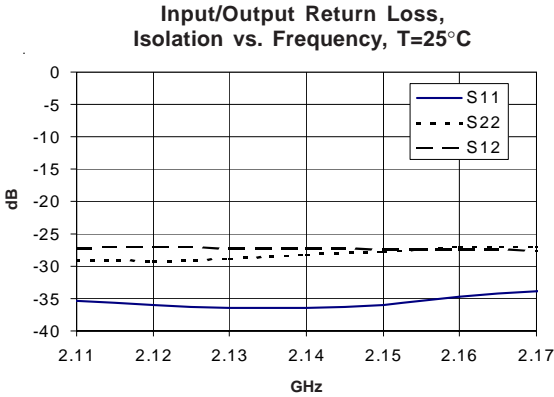
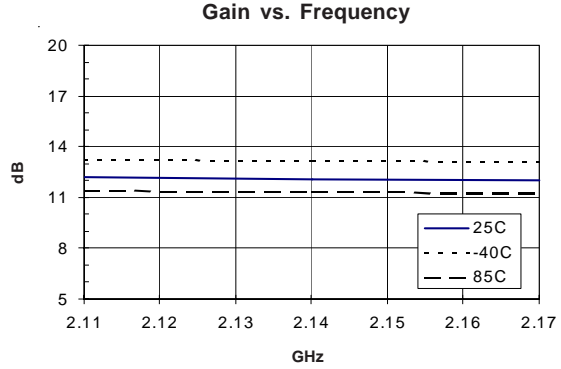
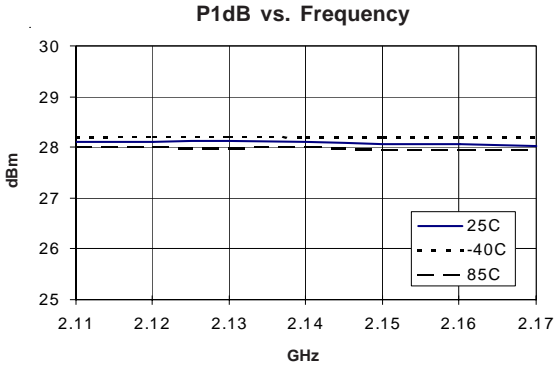



Application Schematic (850 MHz)

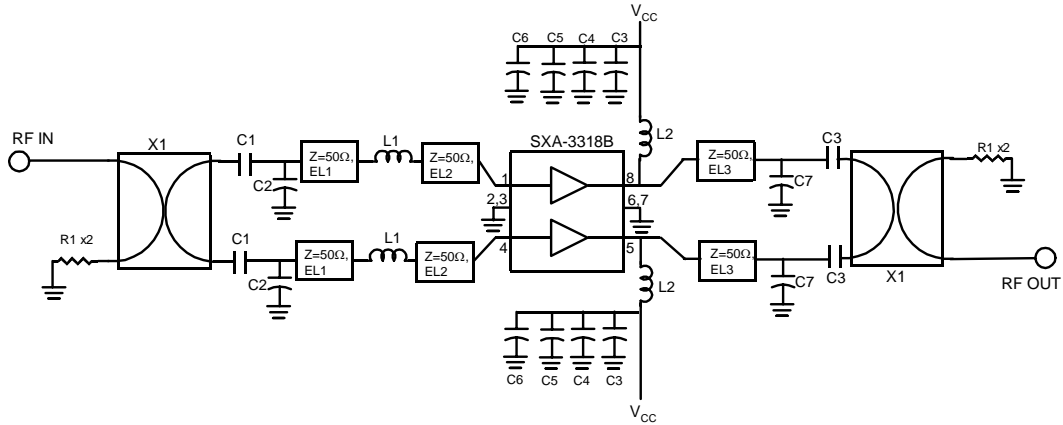

Ref. Des.	Vendor Series	850 MHz
C1, C3	Rohm MCH18	47pF, 5%
C2	Rohm MCH18	3.9pF, ± 0.25 pF
C4	Rohm MCH18	1000pF, 5%
C5	Rohm TAJB104KLRH	0.1uF, 10%
C6	Rohm TAJB106K020R	10uF, 10%
C7	Rohm MCH18	3.3pF, ± 0.25 pF
L1	Toko LL1608-FS	1.2nH, ± 0.3 nH

Ref. Des.	Vendor Series	850 MHz
L2	Toko LL1608-FS	33nH, 5%
EL1	50 Ohms	9.9°
EL2	50 Ohms	4.4°
EL3	50 Ohms	11°
X1	Sirenza Coupler	AH03L
R1	Rohm MCR100J	100 Ohm, 5%

Evaluation Board Layout (850 MHz)

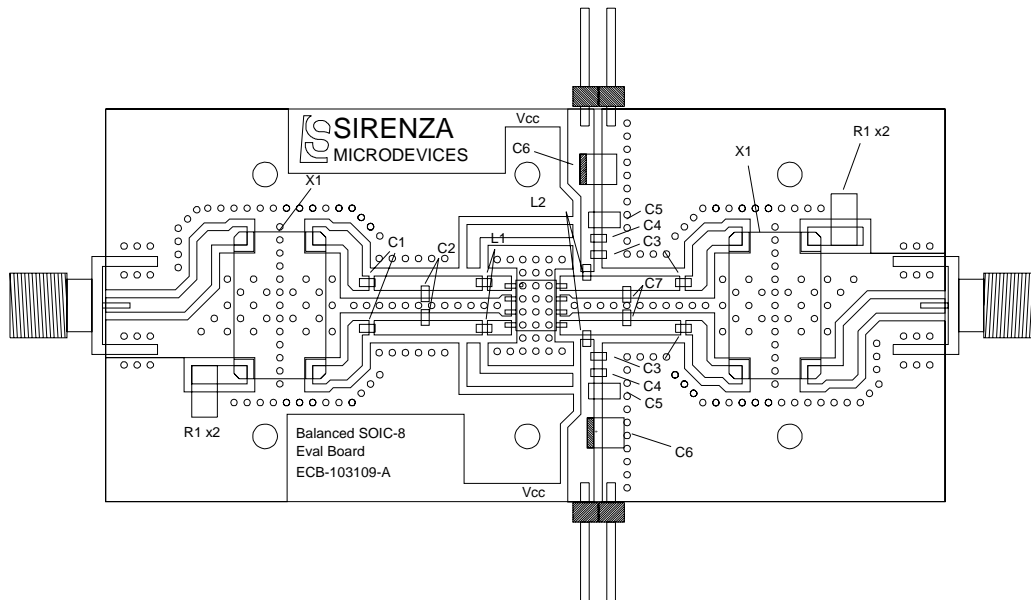



Application Schematic (1960 MHz, 2140 MHz)

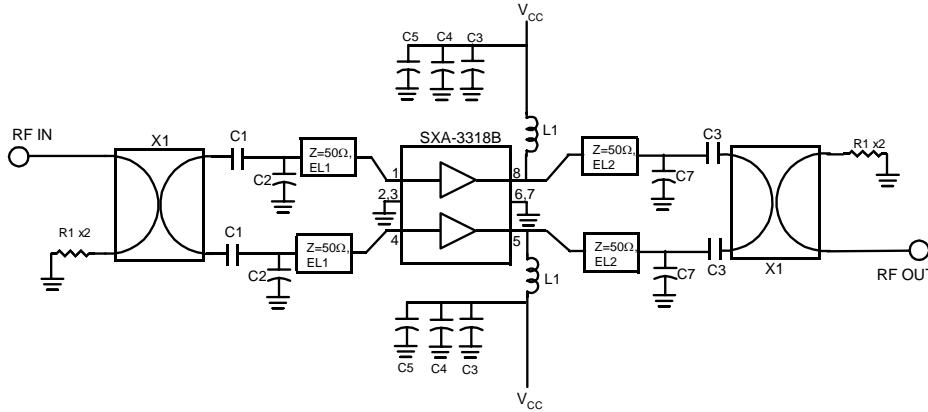

Ref. Des.	Vendor Series	1960 MHz	2140 MHz
C1, C3	Rohm MCH18	22pF, 5%	22pF, 5%
C2	Rohm MCH18	1.2pF, ± 0.25 pF	1.2pF, ± 0.25 pF
C4	Rohm MCH18	1000pF, 5%	1000pF, 5%
C5	Rohm TAJB104KLRH	0.1uF, 10%	0.1uF, 10%
C7	Rohm MCH18	1.0pF, ± 0.25 pF	1.0pF, ± 0.25 pF

Ref. Des.	Vendor Series	1960 MHz	2140 MHz
L1	Toko LL1608-FS	18nH, 5%	18nH, 5%
EL1	50 Ohms	10.1°	11°
EL2	50 Ohms	20.9°	22.8°
X1	Sirenza Coupler	AM03M	AM03M
R1	Rohm MCR100J	100 Ohm, 5%	100 Ohm, 5%

Evaluation Board Layout (1960 MHz, 2140 MHz)

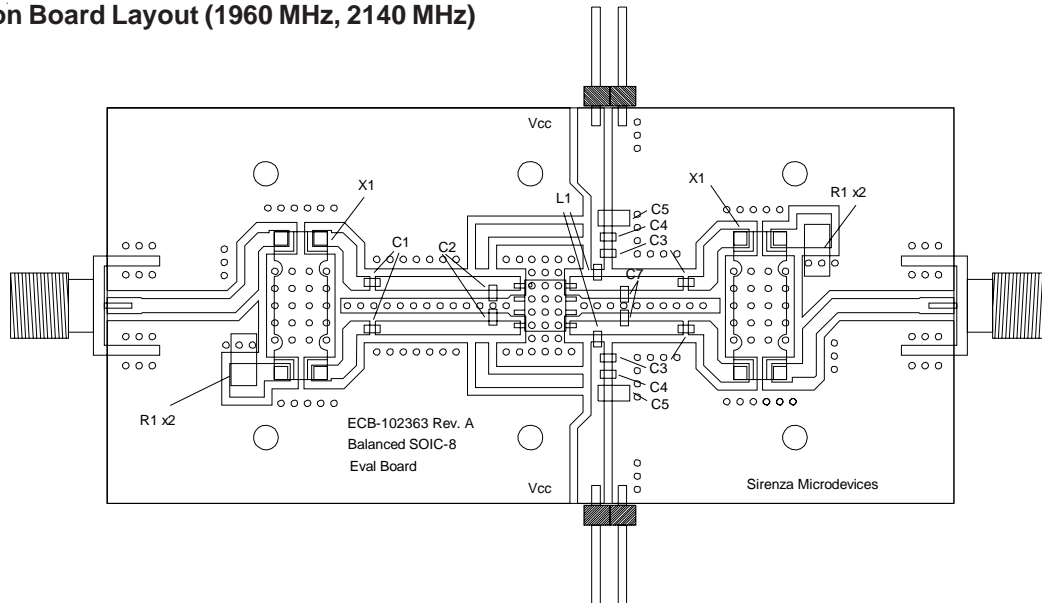



Pin #	Function	Description	Device Schematic
1, 4	RF In	RF input pin. This pin requires the use of an external DC blocking capacitor.	
2, 3, 6, 7	GND	Connection to ground. Use via holes to reduce lead inductance. Place vias as close to ground leads as possible.	
5, 8	RF Out/Vcc	RF output and bias pin. Bias should be supplied to this pin through an external RF choke. Because DC biasing is present on this pin, a DC blocking capacitor should be used in most applications (see application schematic). The supply side of the bias network should be well bypassed. An output matching network is necessary for optimum performance.	
EPAD	GND	Exposed area on the bottom side of the package needs to be soldered to the ground plane of the board for thermal and RF performance. Several vias should be located under the EPAD as shown in the recommended land pattern (page 8).	

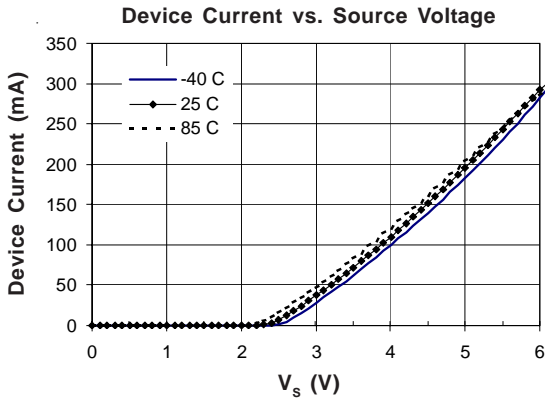

Absolute Maximum Ratings

Parameter	Absolute Limit
Max. Supply Current (I_b) per amplifier (2 amplifiers per packaged part)	240 mA
Max. Device Voltage (V_{cc})	6.0 V
Max. Power Dissipation per amplifier (2 amplifiers per packaged part)	1500 mW
Max. RF Input Power per amplifier (2 amplifiers per packaged part)	100 mW
Max. Junction Temp. (T_j)	+160 °C
Operating Lead Temp. (T_L)	-40 to +85 °C
Max. Storage Temp.	+150 °C

Operation of this device beyond any one of these limits may cause permanent damage. For reliable continuous operation, the device voltage and current must not exceed the maximum operating values specified in the table on page one.

Bias Conditions should also satisfy the following expression:
 $I_b V_{cc} (max) < (T_j - T_L) / R_{\theta j-L}$



ESD: Class 1B (Passes 500V ESD pulse)

Appropriate precautions in handling, packaging and testing devices must be observed.

Moisture Sensitivity Level: Level 1 (MSL-1)

No special moisture packaging/handling is required during storage, shipment, or installation of the devices.



Recommended Land Pattern

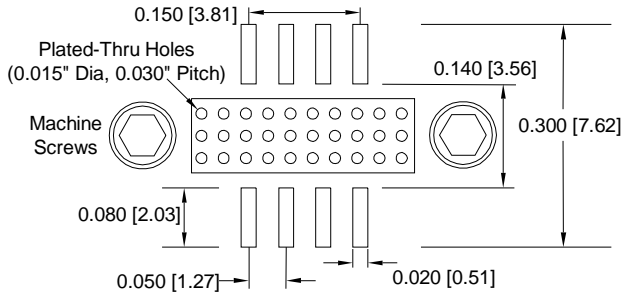

Part Number Ordering Information

Part Number	Devices Per Reel	Reel Size
SXA-3318B	500	7"
SXA-3318BZ	500	7"

Part Symbolization

The part will be symbolized with a "SXA3318B" or "SXA3318BZ" designator on the top surface of the package.

Package Outline Drawing

(See SMDI MPO-101644 for tolerances)

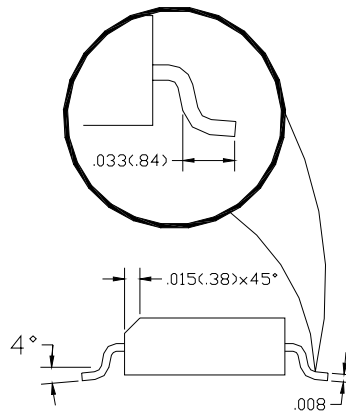
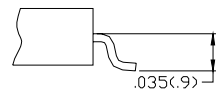
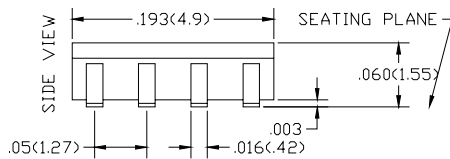
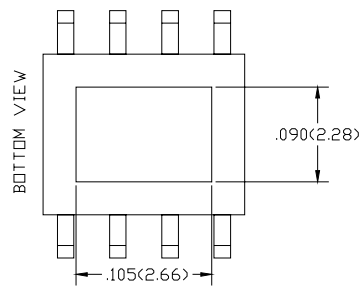
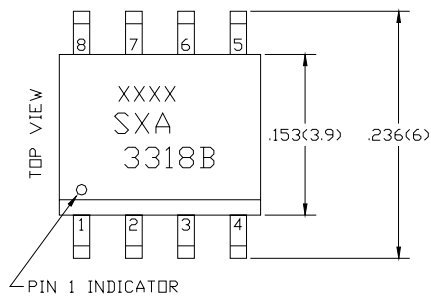

Note: XXXX represents the lot code
 DIMENSIONS ARE IN INCHES [MM]

SUNSTAR 商斯达实业集团是集研发、生产、工程、销售、代理经销、技术咨询、信息服务等为一体的高科技企业，是专业高科技电子产品生产厂家，是具有 10 多年历史的专业电子元器件供应商，是中国最早和最大的仓储式连锁规模经营大型综合电子零部件代理分销商之一，是一家专业代理和分销世界各大品牌 IC 芯片和电子元器件的连锁经营综合性国际公司，专业经营进口、国产名厂名牌电子元件，型号、种类齐全。在香港、北京、深圳、上海、西安、成都等全国主要电子市场设有直属分公司和产品展示展销窗口门市部专卖店及代理分销商，已在全国范围内建成强大统一的供货和代理分销网络。我们专业代理经销、开发生产电子元器件、集成电路、传感器、微波光电元器件、工控机/DOC/DOM 电子盘、专用电路、单片机开发、MCU/DSP/ARM/FPGA 软件硬件、二极管、三极管、模块等，是您可靠的一站式现货配套供应商、方案提供商、部件功能模块开发配套商。商斯达实业公司拥有庞大的资料库，有数位毕业于著名高校——有中国电子工业摇篮之称的西安电子科技大学（西军电）并长期从事国防尖端科技研究的高级工程师为您精挑细选、量身订做各种高科技电子元器件，并解决各种技术问题。

微波光电部专业代理经销高频、微波、光纤、光电元器件、组件、部件、模块、整机；电磁兼容元器件、材料、设备；微波 CAD、EDA 软件、开发测试仿真工具；微波、光纤仪器仪表。欢迎国外高科技微波、光纤厂商将优秀产品介绍到中国、共同开拓市场。长期大量现货专业批发高频、微波、卫星、光纤、电视、CATV 器件：晶振、VCO、连接器、PIN 开关、变容二极管、开关二极管、低噪晶体管、功率电阻及电容、放大器、功率管、MMIC、混频器、耦合器、功分器、振荡器、合成器、衰减器、滤波器、隔离器、环行器、移相器、调制解调器；光电子器件和组件：红外发射管、红外接收管、光电开关、光敏管、发光二极管和发光二极管组件、半导体激光二极管和激光器组件、光电探测器和光接收组件、光发射接收模块、光纤激光器和光放大器、光调制器、光开关、DWDM 用光发射和接收器件、用户接入系统光收发器件与模块、光纤连接器、光纤跳线/尾纤、光衰减器、光纤适配器、光隔离器、光耦合器、光环行器、光复用器/转换器；无线收发芯片和模组、蓝牙芯片和模组。

更多产品请看本公司产品专用销售网站：

商斯达中国传感器科技信息网：<http://www.sensor-ic.com/>

商斯达工控安防网：<http://www.pc-ps.net/>

商斯达电子元器件网：<http://www.sunstare.com/>

商斯达微波光电产品网：[HTTP://www.rfoe.net/](http://www.rfoe.net/)

商斯达消费电子产品网：<http://www.icasic.com/>

商斯达实业科技产品网：<http://www.sunstars.cn/> 微波元器件销售热线：

地址：深圳市福田区福华路福庆街鸿图大厦 1602 室

电话：0755-82884100 83397033 83396822 83398585

传真：0755-83376182 (0) 13823648918 MSN: SUNS8888@hotmail.com

邮编：518033 E-mail:szss20@163.com QQ: 195847376

深圳赛格展销部：深圳华强北路赛格电子市场 2583 号 电话：0755-83665529 25059422

技术支持：0755-83394033 13501568376

欢迎索取免费详细资料、设计指南和光盘；产品凡多，未能尽录，欢迎来电查询。

北京分公司：北京海淀区知春路 132 号中发电子大厦 3097 号

TEL: 010-81159046 82615020 13501189838 FAX: 010-62543996

上海分公司：上海市北京东路 668 号上海赛格电子市场 D125 号

TEL: 021-28311762 56703037 13701955389 FAX: 021-56703037

西安分公司：西安高新开发区 20 所(中国电子科技集团导航技术研究所)

西安劳动南路 88 号电子商城二楼 D23 号

TEL: 029-81022619 13072977981 FAX:029-88789382