

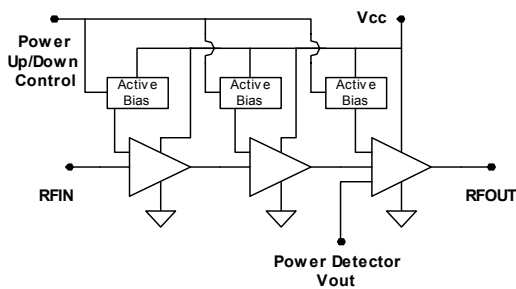

Product Description

Sirenza Microdevices' SZA-5044 is a high efficiency class AB Heterojunction Bipolar Transistor (HBT) amplifier housed in a low-cost surface-mountable plastic package. This HBT amplifier is made with InGaP on GaAs device technology and fabricated with MOCVD for an ideal combination of low cost and high reliability. This product is specifically designed as a final or driver stage for 802.11a equipment in the 4.9 - 5.9 GHz band for a 5V supply. Optimized on-chip impedance matching circuitry provides a 50Ω nominal RF input impedance. A single external output matching circuit covers the entire 4.9-5.9GHz band simultaneously. The external output match allows for load line optimization for other applications or optimized performance over narrower bands. This product is available in a RoHS Compliant and Green package with matte tin finish, designated by the "Z" package suffix.

Functional Block Diagram



Key Specifications

Symbol	Parameters: Test Conditions, App circuit page 4 $Z_0 = 50\Omega$, $V_{CC} = 5.0V$, $I_{CQ} = 220mA$, $T_{BP} = 25^\circ C$	Unit	Min.	Typ.	Max.
f_O	Frequency of Operation	MHz	4900		5900
P_{1dB}	Output Power at 1dB Compression - 5.15 GHz	dBm		29.5	
	Output Power at 1dB Compression - 5.875 GHz		26.5	28.0	
S_{21}	Gain at 4.9 GHz	dB	27.5	29.5	31.5
	Gain at 5.15 GHz	dB		29.5	
	Gain at 5.875 GHz	dB	24.0	26.0	28.0
P_{out}	Output power at 3% EVM 802.11a 54Mb/s - 5.15GHz	dBm		22	
	Output Power at 3% EVM 802.11a 54Mb/s - 5.875GHz			21	
NF	Noise Figure at 5.875 GHz	dB		6.3	
IM3	Third Order Intermod at 18dBm per tone - 5.875GHz	dBc		-36	-32
IRL	Worst Case Input Return Loss 4.9-5.875GHz	dB	11.5	14.5	
ORL	Worst Case Output Return Loss 4.9-5.875GHz		8.0	11.0	
Vdet Range	Output Voltage Range for $P_{out}=10dBm$ to $26dBm$	V		0.8 to 1.9	
I_{CQ}	V_{CC} Quiescent Current	mA	185	220	255
I_{VPC}	Power Up Control Current, $V_{pc}=5V$ ($I_{VPC1} + I_{VPC2} + I_{VPC3}$)	mA		1.7	
I_{LEAK}	Off V_{CC} Leakage Current $V_{pc}=0V$	uA		8	100
$R_{th, j-l}$	Thermal Resistance (junction - lead)	$^\circ C/W$		24	

The information provided herein is believed to be reliable at press time. Sirenza Microdevices assumes no responsibility for inaccuracies or omissions. Sirenza Microdevices assumes no responsibility for the use of this information, and all such information shall be entirely at the user's own risk. Prices and specifications are subject to change without notice. No patent rights or licenses to any of the circuits described herein are implied or granted to any third party. Sirenza Microdevices does not authorize or warrant any Sirenza Microdevices product for use in life-support devices and/or systems.

Copyright 2002 Sirenza Microdevices, Inc. All worldwide rights reserved.
303 South Technology Court Broomfield, CO 80021

Phone: (800) SMI-MMIC

<http://www.sirenza.com>
EDS-103585 Rev F

SZA-5044

SZA-5044Z RoHS Compliant & Green Package

4.9 – 5.9 GHz 5V Power Amplifier

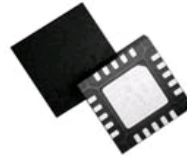

4mm x 4mm QFN Package

Product Features

- 802.11a 54Mb/s Class AB Performance
Pout = 21.5dBm @ 3% EVM, 5V, 310mA
- High Gain = 28dB
- Output Return Loss < -11dB for Linear Tune
- On-chip Output Power Detector
- P1dB = 29dBm @ 5V
- Simultaneous 4.9- 5.9GHz Performance
- Robust - Survives RF Input Power = +15dBm
- Power up/down control < 1μs, Vpc 2.9V to 5V

Applications

- 802.11a WLAN, OFDM
- 5.8GHz ISM Band, 802.16 WiMAX



SZA-5044 4.9-5.9 GHz Power Amp

Pin Out Description

Pin #	Function	Description
1,3,5,9,11,15,17	N/C	Pins are not used. May be grounded, left open, or connected to adjacent pin.
6	VPC1	VPC1 is the bias control pin for the stage 1 active bias circuit and can be run from 2.9V to 5V control. An external series resistor is required for proper setting of bias levels depending on control voltage. Refer to the evaluation board schematic for resistor value. To prevent potential damage, do not apply voltage to this pin that is +1V greater than voltage applied to pin 20 (Vbias) unless Vpc supply current capability is less than 10 mA.
7	VPC2	VPC2 is the bias control pin for the stage 2 active bias circuit and can be run from 2.9V to 5V control. An external series resistor is required for proper setting of bias levels depending on control voltage. Refer to the evaluation board schematic for resistor value. To prevent potential damage, do not apply voltage to this pin that is +1V greater than voltage applied to pin 20 (Vbias) unless Vpc supply current capability is less than 10 mA.
8	VPC3	VPC3 is the bias control pin for the stage 3 active bias circuit and can be run from 2.9V to 5V control. An external series resistor is required for proper setting of bias levels depending on control voltage. Refer to the evaluation board schematic for resistor value. To prevent potential damage, do not apply voltage to this pin that is +1V greater than voltage applied to pin 20 (Vbias) unless Vpc supply current capability is less than 10 mA.
10	Vdet	Ouput power detector voltage. Load with 10K-100K ohms to ground for best performance.
2,4	RFIN	RF input pins. This is DC grounded internal to the IC. Do not apply voltage to this pin. All three pins must be used for proper operation.
12,13,14	RFOUT	RF output pin. This is also another connection to the 3rd stage collector
16	VC3	3rd stage collector bias pin. Apply 5V to this pin.
18	VC2	2nd stage collector bias pin. Apply 5V to this pin.
19	VC1	1st stage collector bias pin. Apply 5V to this pin.
20	Vbias	Active bias network VCC. Apply 5V to this pin.
EPAD	Gnd	Exposed area on the bottom side of the package needs to be soldered to the ground plane of the board for optimum thermal and RF performance. Several vias should be located under the EPAD as shown in the recommended land pattern (page 5).

Simplified Device Schematic

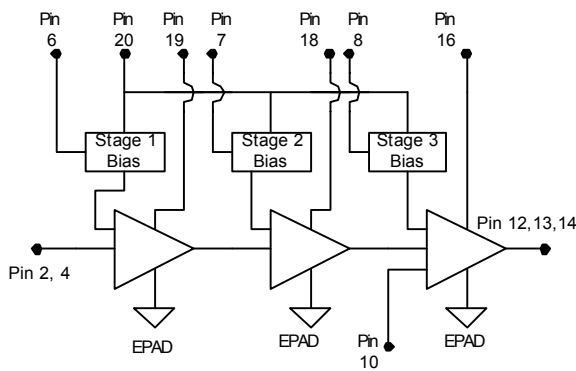

Absolute Maximum Ratings

Parameters	Value	Unit
VC3 Collector Bias Current (pin16)	500	mA
VC2 Collector Bias Current (pin18)	225	mA
VC1 Collector Bias Current (pin19)	75	mA
Device Voltage (V _D)	7.0	V
Power Dissipation	3.4	W
Operating Lead Temperature (T _L)	-40 to +85	°C
RF Input Power for 50 ohm RF out load	15	dBm
RF Input Power for 10:1 VSWR RF out load	2	dBm
Storage Temperature Range	-40 to +150	°C
Operating Junction Temperature (T _J)	+150	°C
ESD Human Body Model	>1000	V

Operation of this device beyond any one of these limits may cause permanent damage. For reliable continuous operation the device voltage and current must not exceed the maximum operating values specified in the table on page one.

Bias conditions should also satisfy the following expression:

$$I_D V_D < (T_J - T_L) / R_{TH} j-1$$



Caution: ESD Sensitive

Appropriate precaution in handling, packaging and testing devices must be observed.



SZA-5044 4.9-5.9 GHz Power Amp

4.9 - 5.9 GHz Evaluation Board Data ($V_{BIAS} = 5.0V, I_q = 220mA$)

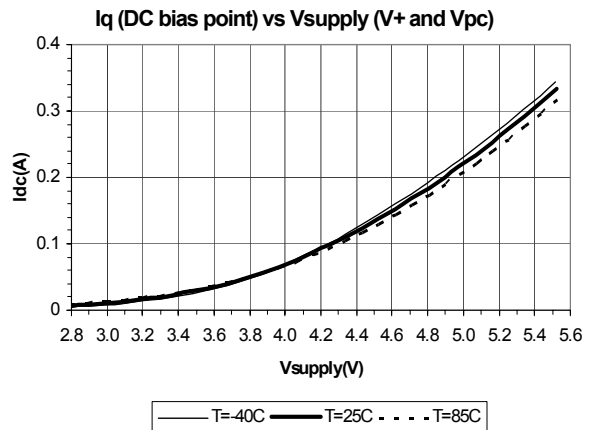
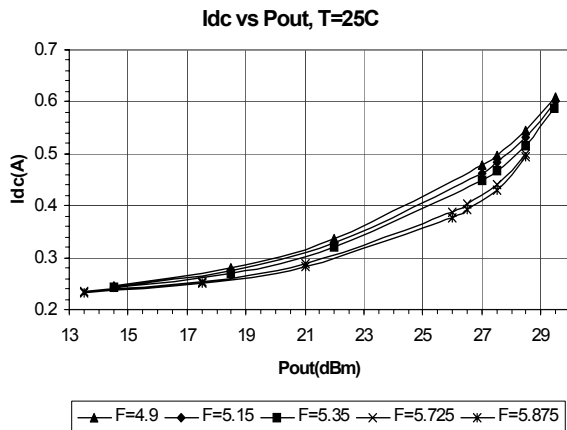
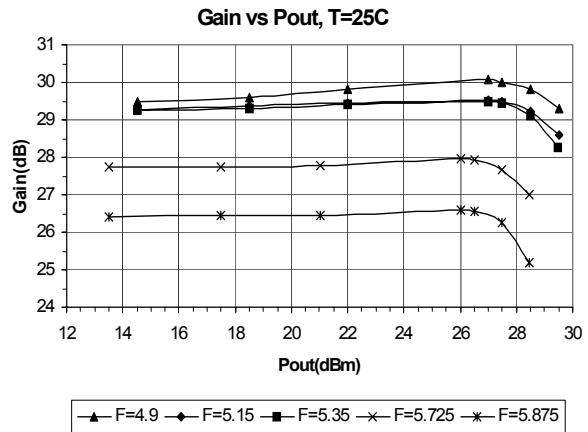
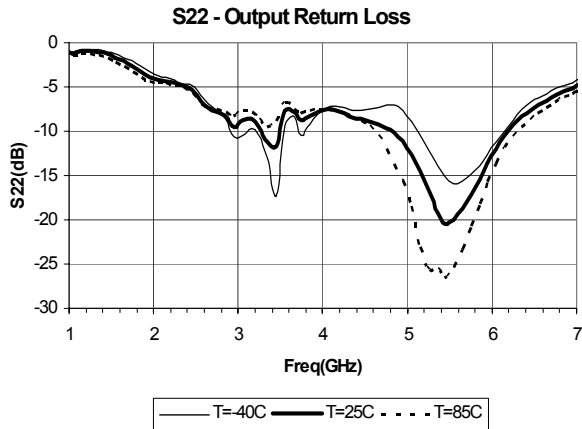
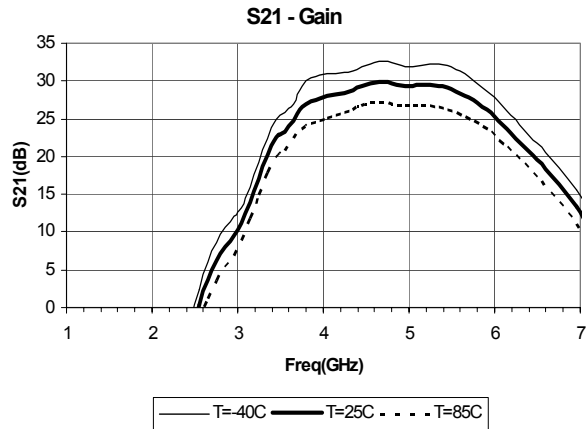
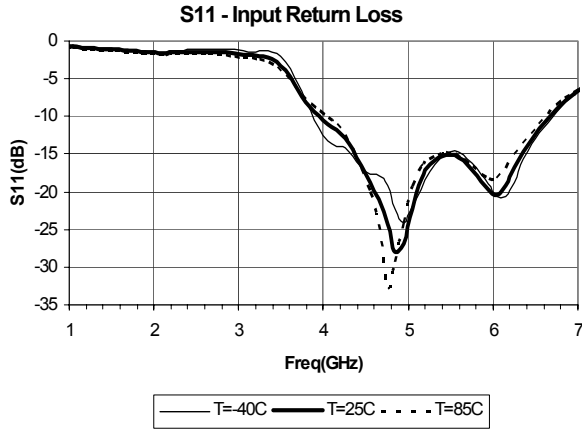



SZA-5044 4.9-5.9 GHz Power Amp

4.9 - 5.9 GHz Evaluation Board Data ($V_{BIAS} = 5.0V, I_q = 220mA$)
802.11a EVM, OFDM, 54Mb/s, 64QAM

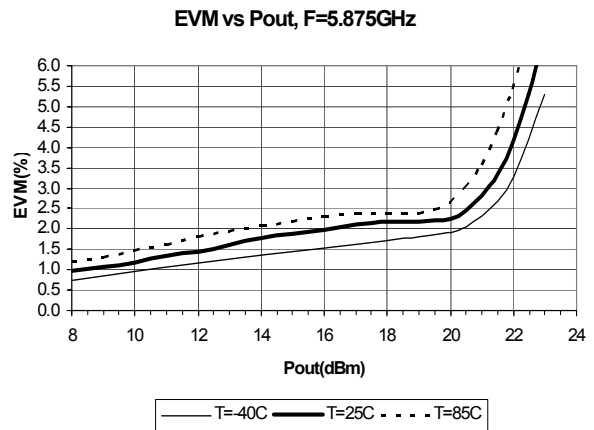
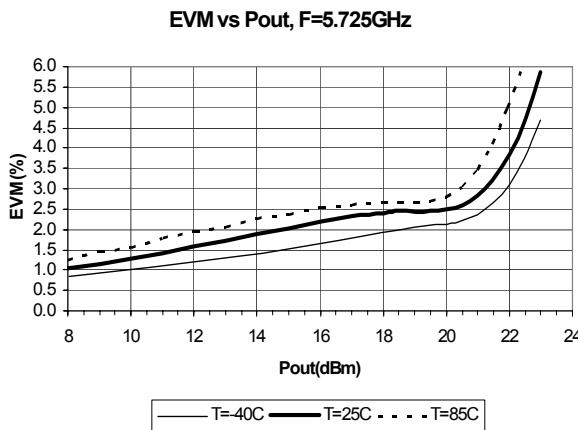
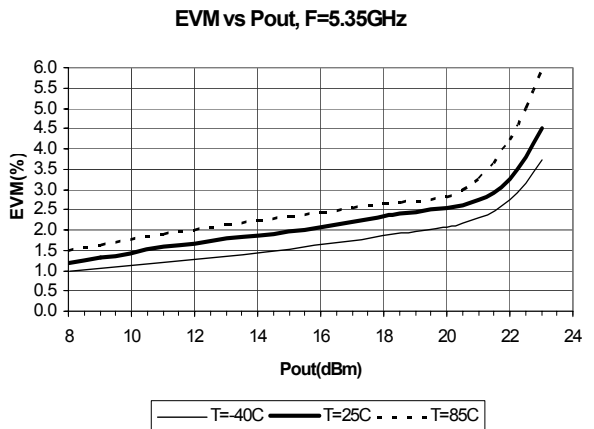
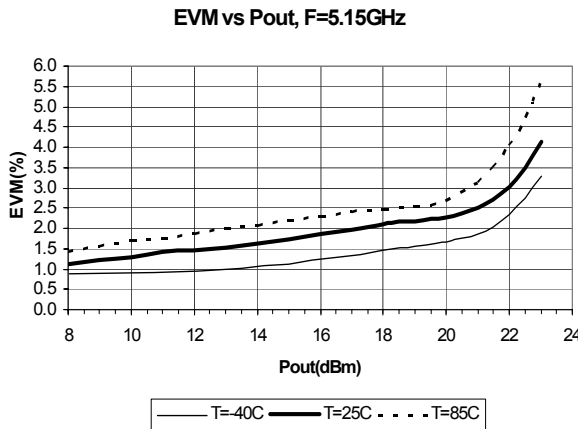
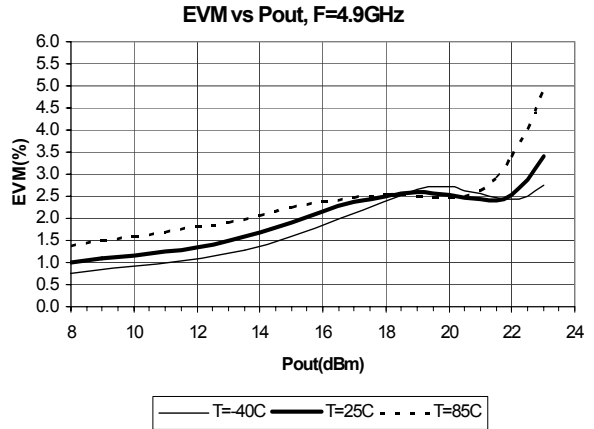
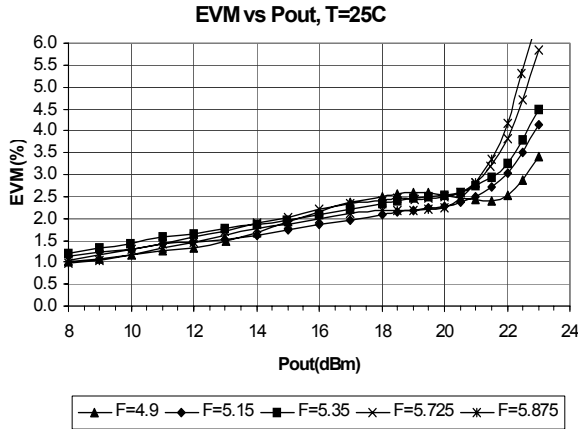



SZA-5044 4.9-5.9 GHz Power Amp

4.9 - 5.9 GHz Evaluation Board Data ($V_{BIAS} = 5.0V, I_q = 220mA$)

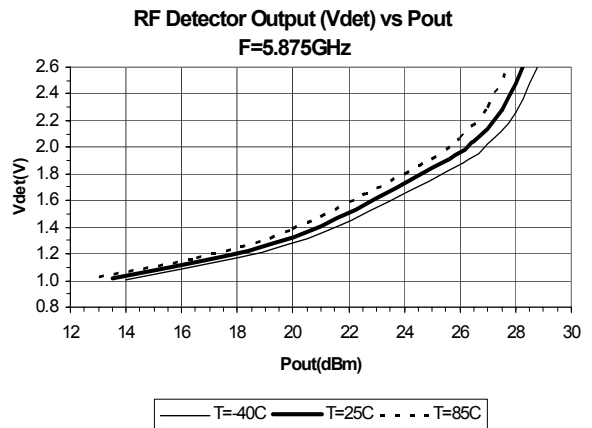
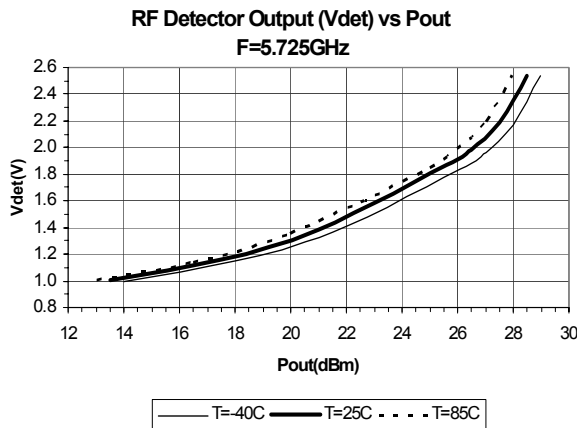
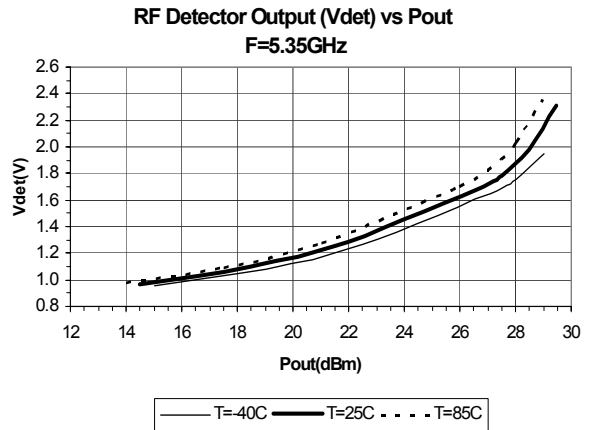
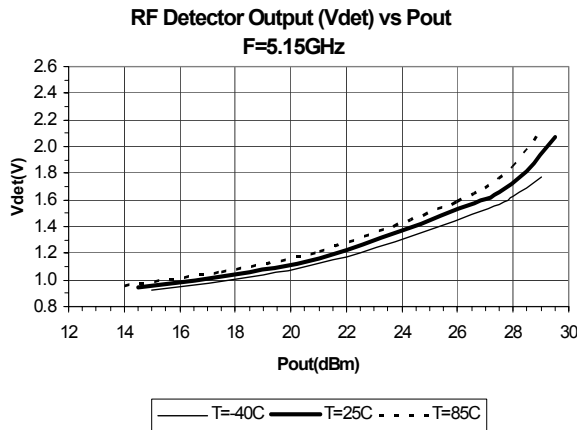
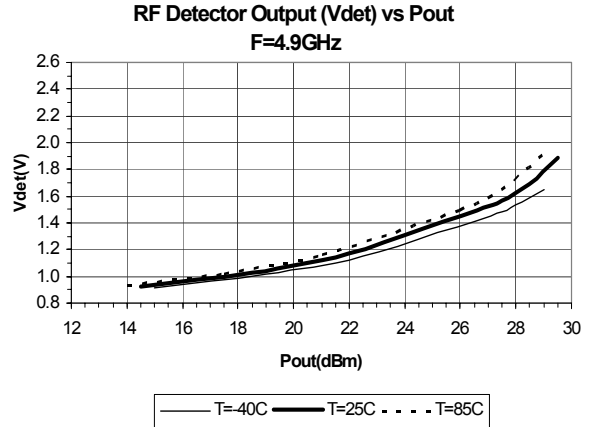
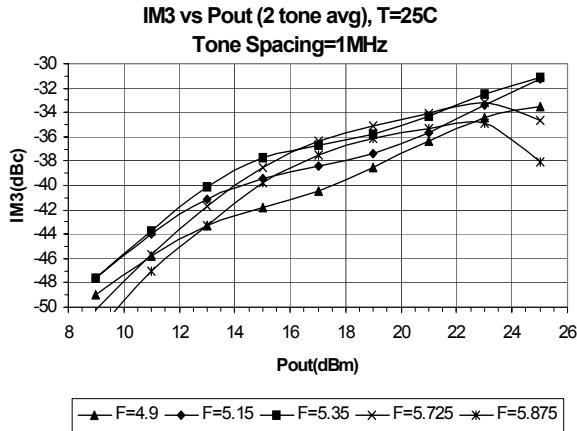



SZA-5044 4.9-5.9 GHz Power Amp

4.9 - 5.9 GHz Evaluation Board Data with Improved Linearity Bias ($V_{BIAS} = 5.0V, I_q = 270mA$)

Note: Linearity improvements are primarily at backed off Pout levels. EVM data is 802.11a, OFDM, 54Mb/s, 64QAM

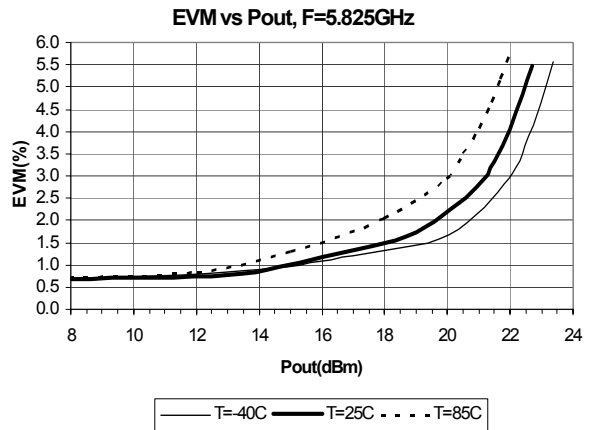
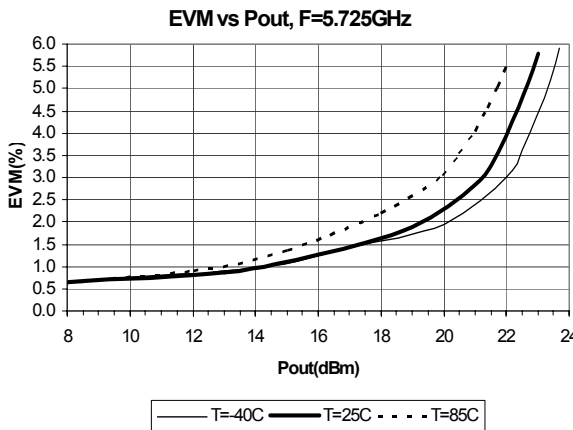
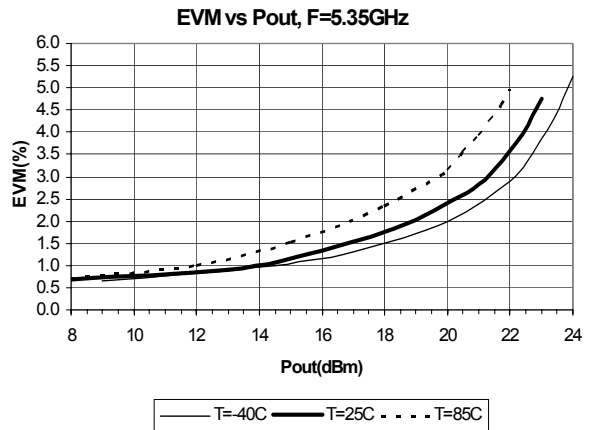
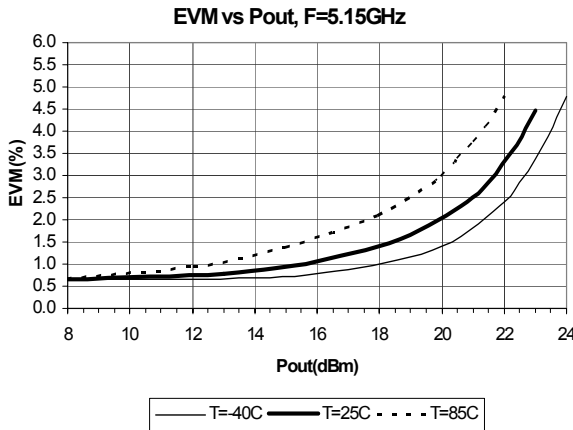
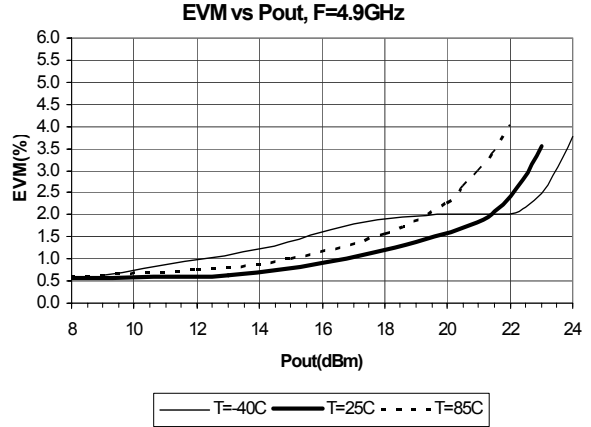
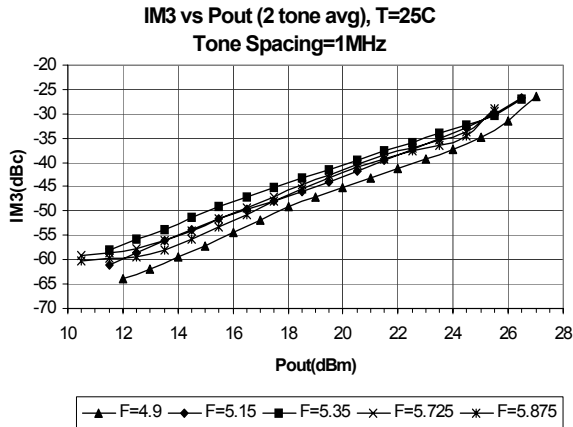



SZA-5044 4.9-5.9 GHz Power Amp

4.9 - 5.9 GHz Evaluation Board Schematic For V+ = Vcc = 5.0V

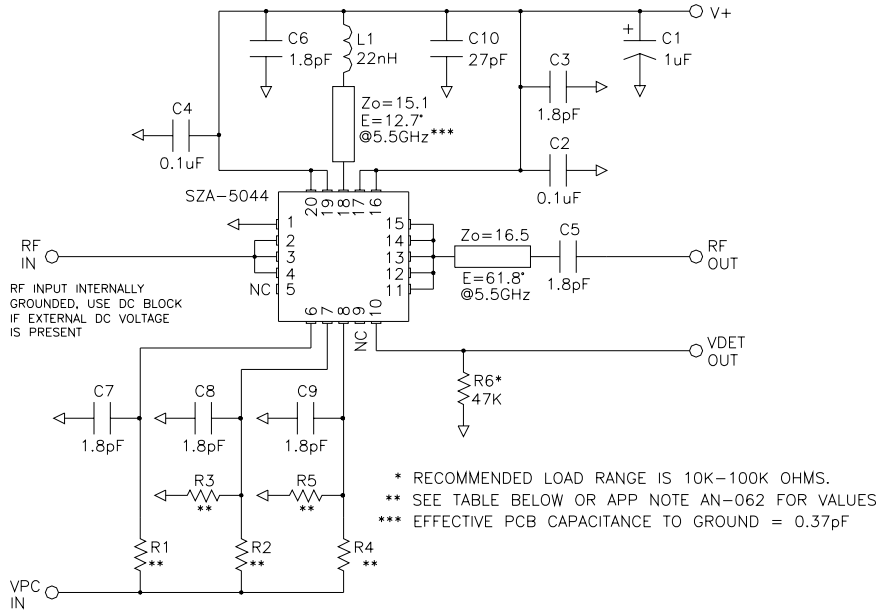

Notes:

Pins 1,3,5,9,11,15 and 17 are unwired (N/C) inside the package. Refer to page 2 for detailed pin descriptions. Some of these pins are wired to adjacent pins or grounded as shown in the application circuit. This is to maintain consistency with the evaluation board layout shown below. It is recommended to use this layout and wiring to achieve the specified performance.

To prevent potential damage, do not apply voltage to the Vpc pin that is +1V greater than voltage applied to pin 20 (Vbias/Vcc) unless Vpc supply current capability is less than 10 mA.

4.9 - 5.9 GHz Evaluation Board Layout For V+ = Vcc = 5.0V

- Board material GETEK, 10mil thick, Dk=3.9, 2 oz. copper finish

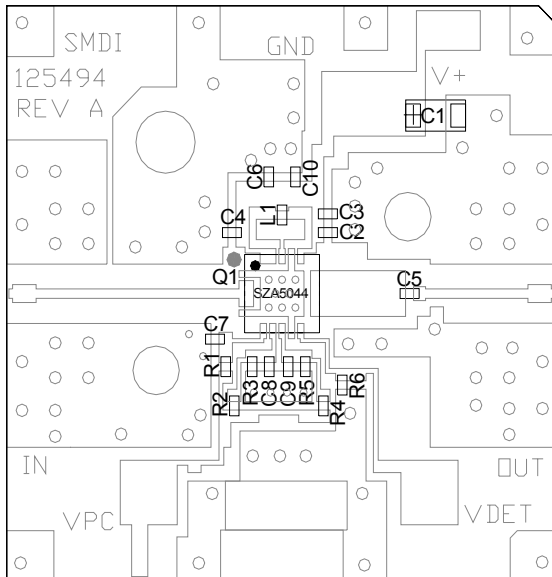

DESG	DESCRIPTION
Q1	SZA-5044
R1,2,3,4,5,6	1%, 0402
C1	1uF 16V TANTALUM CAP
C2,4	0.1uF CAP, 0402
C3,5,6,7,8,9	1.8pF CAP, 0402
C10	27pF CAP, 0402
L1	22nH IND, 0402

Resistor values for Vpc=2.9V to 5V (Vcc=5V, Iq=220mA)

VPC(V)	R1	R2	R4	R3	R5
2.9	0	698	221	OUT	OUT
3.0	174	1.1K	604	OUT	OUT
3.1	348	1.37K	909	OUT	OUT
3.2	511	1.78K	1.24K	OUT	OUT
3.3	698	2.15K	1.5K	OUT	OUT
5.0	3.74K	2.49K	7.15K	7.5K	OUT

Resistor values for Vpc=2.9V to 5V (Vcc=5V, Iq=270mA)

VPC(V)	R1	R2	R4	R3	R5
2.9	0	698	10	OUT	OUT
3.0	174	1.1K	261	OUT	OUT
3.1	348	1.37K	499	OUT	OUT
3.2	511	1.78K	750	OUT	OUT
3.3	698	2.15K	1.00K	OUT	OUT
5.0	3.74K	2.49K	2.61K	7.5K	7.5K

Note: See app note AN-062 for other Vcc and Vpc combinations



SZA-5044 4.9-5.9 GHz Power Amp

Part Symbolization

The part will be symbolized with an "SZA-5044" for Sn/Pb plating or "SZA-5044Z" for RoHS green compliant product. Marking designator will be on the top surface of the package.

Part Number Ordering Information

Part Number	Reel Size	Devices/Reel
SZA-5044	13"	3000
SZA-5044Z	13"	3000

Package Outline Drawing (dimensions in mm): Refer to package outline drawing for more detail.

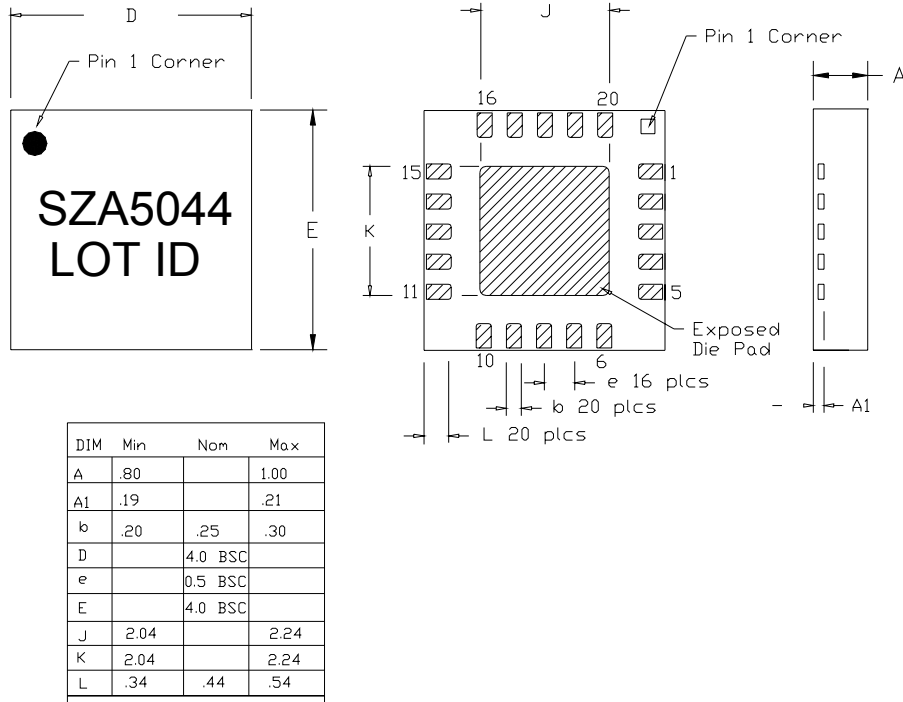

Recommended Land Pattern (dimensions in mm[in])

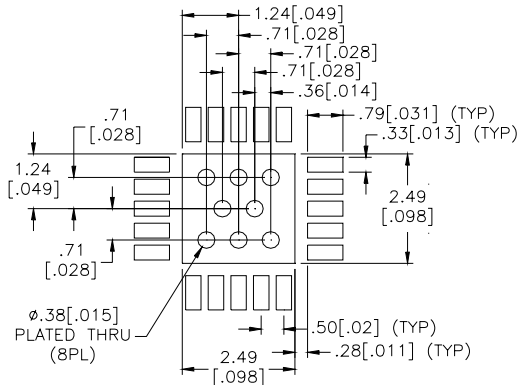

Recommended PCB Soldermask (SBOC) for Land Pattern (dimensions in mm[in]):

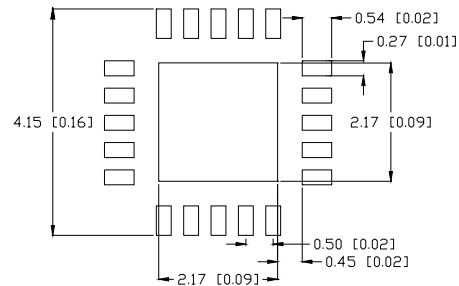

SUNSTAR 商斯达实业集团是集研发、生产、工程、销售、代理经销、技术咨询、信息服务等为一体的高科技企业，是专业高科技电子产品生产厂家，是具有 10 多年历史的专业电子元器件供应商，是中国最早和最大的仓储式连锁规模经营大型综合电子零部件代理分销商之一，是一家专业代理和分销世界各大品牌 IC 芯片和电子元器件的连锁经营综合性国际公司，专业经营进口、国产名厂名牌电子元件，型号、种类齐全。在香港、北京、深圳、上海、西安、成都等全国主要电子市场设有直属分公司和产品展示展销窗口门市部专卖店及代理分销商，已在全国范围内建成强大统一的供货和代理分销网络。我们专业代理经销、开发生产电子元器件、集成电路、传感器、微波光电元器件、工控机/DOC/DOM 电子盘、专用电路、单片机开发、MCU/DSP/ARM/FPGA 软件硬件、二极管、三极管、模块等，是您可靠的一站式现货配套供应商、方案提供商、部件功能模块开发配套商。商斯达实业公司拥有庞大的资料库，有数位毕业于著名高校——有中国电子工业摇篮之称的西安电子科技大学（西军电）并长期从事国防尖端科技研究的高级工程师为您精挑细选、量身订做各种高科技电子元器件，并解决各种技术问题。

微波光电部专业代理经销高频、微波、光纤、光电元器件、组件、部件、模块、整机；电磁兼容元器件、材料、设备；微波 CAD、EDA 软件、开发测试仿真工具；微波、光纤仪器仪表。欢迎国外高科技微波、光纤厂商将优秀产品介绍到中国、共同开拓市场。长期大量现货专业批发高频、微波、卫星、光纤、电视、CATV 器件：晶振、VCO、连接器、PIN 开关、变容二极管、开关二极管、低噪晶体管、功率电阻及电容、放大器、功率管、MMIC、混频器、耦合器、功分器、振荡器、合成器、衰减器、滤波器、隔离器、环行器、移相器、调制解调器；光电子器件和组件：红外发射管、红外接收管、光电开关、光敏管、发光二极管和发光二极管组件、半导体激光二极管和激光器组件、光电探测器和光接收组件、光发射接收模块、光纤激光器和光放大器、光调制器、光开关、DWDM 用光发射和接收器件、用户接入系统光收发器件与模块、光纤连接器、光纤跳线/尾纤、光衰减器、光纤适配器、光隔离器、光耦合器、光环行器、光复用器/转换器；无线收发芯片和模组、蓝牙芯片和模组。

更多产品请看本公司产品专用销售网站：

商斯达中国传感器科技信息网：<http://www.sensor-ic.com/>

商斯达工控安防网：<http://www.pc-ps.net/>

商斯达电子元器件网：<http://www.sunstare.com/>

商斯达微波光电产品网：[HTTP://www.rfoe.net/](http://www.rfoe.net/)

商斯达消费电子产品网：<http://www.icasic.com/>

商斯达实业科技产品网：<http://www.sunstars.cn/> 微波元器件销售热线：

地址：深圳市福田区福华路福庆街鸿图大厦 1602 室

电话：0755-82884100 83397033 83396822 83398585

传真：0755-83376182 (0) 13823648918 MSN: SUNS8888@hotmail.com

邮编：518033 E-mail:szss20@163.com QQ: 195847376

深圳赛格展销部：深圳华强北路赛格电子市场 2583 号 电话：0755-83665529 25059422

技术支持：0755-83394033 13501568376

欢迎索取免费详细资料、设计指南和光盘；产品凡多，未能尽录，欢迎来电查询。

北京分公司：北京海淀区知春路 132 号中发电子大厦 3097 号

TEL: 010-81159046 82615020 13501189838 FAX: 010-62543996

上海分公司：上海市北京东路 668 号上海赛格电子市场 D125 号

TEL: 021-28311762 56703037 13701955389 FAX: 021-56703037

西安分公司：西安高新开发区 20 所(中国电子科技集团导航技术研究所)

西安劳动南路 88 号电子商城二楼 D23 号

TEL: 029-81022619 13072977981 FAX:029-88789382