

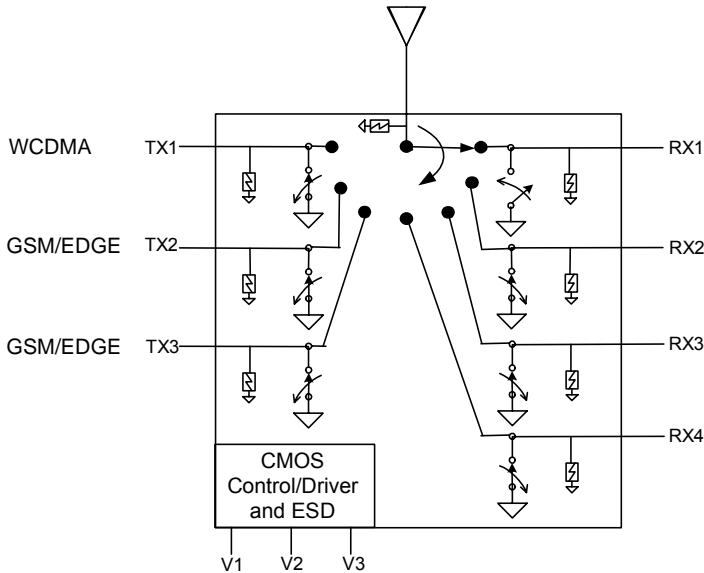

SP7T UltraCMOS™ 2.75 V Switch 100 – 3000 MHz, +67 dBm IIP3

Figure 1. Functional Diagram



Features

- Dedicated TX1 port for WCDMA, TX2 and TX3 ports for GSM/EDGE
- Three pin CMOS logic control with integral decoder/driver
- Exceptional harmonic performance: $2f_o = -85$ dBc and $3f_o = -78.5$ dBc
- Low TX insertion loss: 0.60 dB at 900 MHz, 0.70 dB at 1900 MHz
- TX – RX Isolation of 44 dB at 900 MHz, 38 dB at 1900 MHz
- 1000 V HBM ESD tolerance all ports
- +67 dBm IIP3
- -109 dBm IMD3
- No blocking capacitors required

Figure 2. Die Top View*

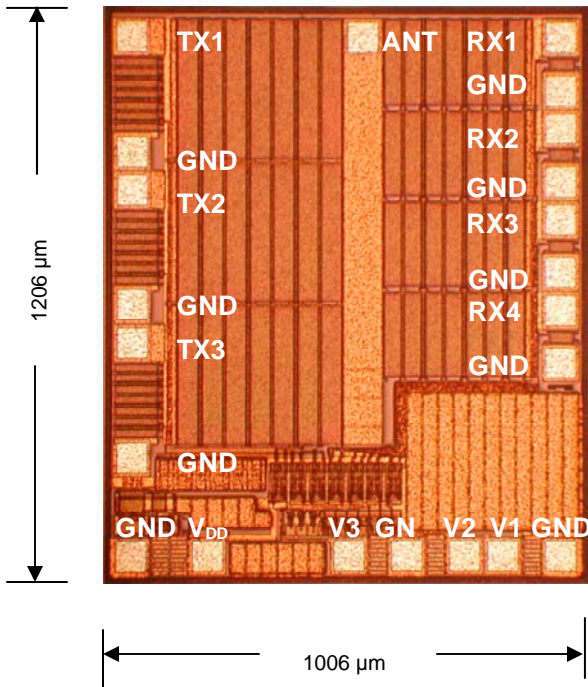

* Dimensions shown are drawn die size.

Product Description

The PE42672 is a HaRP™-enhanced SP7T RF Switch developed on the UltraCMOS™ process technology. It addresses the specific design needs of the Quad-Band GSM Handset Antenna Switch Module Market for use in GSM/EDGE/PCS/DCS/WCDMA handsets. The switch is comprised of three TX ports and four RX ports. TX1 is designed for WCDMA and TX2 and TX3 are designed for GSM/EDGE. The four symmetric RX ports can be used for GSM/EDGE/PCS RX. On-chip CMOS decoder logic facilitates three-pin low voltage CMOS control, while high ESD tolerance of 1000 V at all ports, no blocking capacitor requirements, and on-chip SAW filter over-voltage protection devices make this the ultimate in integration and ruggedness.

Peregrine's HaRP™ technology enhancements deliver high linearity and exceptional harmonics performance. It is an innovative feature of the UltraCMOS™ process, providing performance superior to GaAs with the economy and integration of conventional CMOS.

Table 1. Target Electrical Specifications @ 25 °C, V_{DD} = 2.75 V

Parameter	Condition	Typ	Units
Insertion loss ¹	TX - Ant (850 / 900)	0.6	dB
	TX - Ant (1800 / 1900)	0.7	dB
	TX - Ant (2100 WCDMA)	0.75	dB
	RX - Ant (850 / 900)	0.9	dB
	RX - Ant (1800 / 1900)	0.9	dB
Return Loss	Port under test in on state	20	dB
Isolation	TX - RX (850 / 900)	44	dB
	TX - RX (1800 / 1900)	38	dB
	TX - TX (850 / 900)	29	dB
	TX - TX (1800 / 1900)	23	dB
	TX1 - RX (1900 / 2100)	39	dB
2nd Harmonic	TX 850 / 900 MHz, +35 dBm output power, 50 Ω	-85	dBc
	TX 1800 / 1900 MHz, +33 dBm output power, 50 Ω	-84	dBc
3rd Harmonic	TX 850 / 900 MHz, +35 dBm output power, 50 Ω	-78.5	dBc
	TX 1800 / 1900 MHz, +33 dBm output power, 50 Ω	-78.5	dBc
IMD3 distortion at 2.14 GHz	TX1 Measured at 2.14 GHz at Ant port, input +20 dBm CW signal at 1.95 GHz and -15 dBm CW signal at 1.76 GHz	-109	dBm
WCDMA 2100 IIP3	TX1 Measured at 2.14 GHz at Ant port, input +20 dBm CW signal at 1.95 GHz and -15 dBm CW signal at 1.76 GHz	+67	dBm
Switching time	(10-90%) (90-10%) RF	2	µs

Note: 1. Insertion loss specified with optimal impedance matching.

Table 2. Operating Ranges

Parameter	Symbol	Min	Typ	Max	Units
Temperature range	T _{OP}	-40		+85	°C
V _{DD} Supply Voltage	V _{DD}	2.65	2.75	2.85	V
I _{DD} Power Supply Current (V _{DD} = 2.75 V)	I _{DD}		13	50	µA
TX input power ² (VSWR ≤ 3:1) 824-915 MHz	P _{IN}			+35	dBm
TX input power ² (VSWR ≤ 3:1) 1710-1910 MHz				+33	
RX input power ² (VSWR =1:1)	P _{IN}			+20	dBm
Control Voltage High	V _{IH}	1.4			V
Control Voltage Low	V _{IL}			0.4	V

Note: 2. Assumes RF input period of 4620 µs and duty cycle of 50%.

Table 3. Absolute Maximum Ratings

Symbol	Parameter/Conditions	Min	Max	Units
V _{DD}	Power supply voltage	-0.3	4.0	V
V _I	Voltage on any input	-0.3	V _{DD} + 0.3	V
T _{ST}	Storage temperature range	-65	+150	°C
P _{IN} (50 Ω)	TX input power (50 Ω) ^{3,4} 824-915 MHz		+38	dBm
	TX input power (50 Ω) ^{3,4} 1710-1910 MHz		+36	
	RX input power (50 Ω) ^{3,4}		+23	
P _{IN} (∞:1)	TX input power (VSWR = (∞:1) ^{3,4} 824-915 MHz		+35	dBm
	TX input power (VSWR = (∞:1) ^{3,4} 1710-1910 MHz		+33	
V _{ESD}	ESD Voltage (HBM, MIL_STD 883 Method 3015.7)		1000	V

Note: 3. Assumes RF input period of 4620 µs and duty cycle of 50%.

4. V_{DD} within operating range specified in Table 2.

Part performance is not guaranteed under these conditions. Exposure to absolute maximum conditions for extended periods of time may adversely affect reliability. Stresses in excess of absolute maximum ratings may cause permanent damage.

Table 4. Pin Descriptions

Pin No.	Pin Name	Description
1	ANT	RF Common – Antenna
2	TX1 ⁶	RF I/O - TX1
3	GND ⁵	Ground
4	TX2 ⁶	RF I/O – TX2
5	GND ⁵	Ground
6	TX3	RF I/O – TX3
7	GND ⁵	Ground
8	GND ⁵	Ground
9	V _{DD}	Supply
10	V3	Switch control input, CMOS logic level
11	GND ⁵	Ground
12	V2	Switch control input, CMOS logic level
13	V1	Switch control input, CMOS logic level
14	GND ⁵	Ground
15	GND ⁵	Ground
16	RX4 ⁶	RF I/O – RX4
17	GND ⁵	Ground
18	RX3 ⁶	RF I/O – RX3
19	GND ⁵	Ground
20	RX2 ⁶	RF I/O – RX2
21	GND ⁵	Ground
22	RX1 ⁶	RF I/O – RX1

Notes: 5. Bond wires should be physically short and connected to ground plane for best performance.

6. Blocking capacitors needed only when non-zero DC voltage present.

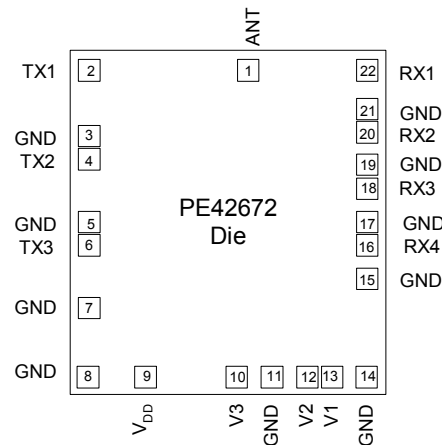
Figure 3. Pad Configuration (Top View)

Table 5. Truth Table

Path	V3	V2	V1
RX1 - ANT	0	0	0
RX2 - ANT	0	0	1
RX3 - ANT	0	1	0
RX4 - ANT	0	1	1
TX1 - ANT	1	0	0
TX2 - ANT	1	0	1
TX3 - ANT	1	1	0
All Off	1	1	1

Electrostatic Discharge (ESD) Precautions

When handling this UltraCMOS™ device, observe the same precautions that you would use with other ESD-sensitive devices. Although this device contains circuitry to protect it from damage due to ESD, precautions should be taken to avoid exceeding the specified rating.

Latch-Up Avoidance

Unlike conventional CMOS devices, UltraCMOS™ devices are immune to latch-up.

Table 6. Ordering Information

Order Code	Description	Package	Shipping Method
42672-90	PE42672-DIE-D	Film Frame	Wafer (Gross Die / Wafer Quantity)
42672-99	PE42672-DIE-400G	Waffle Pack	400 Dice / Waffle Pack
42672-00	PE42672-DIE-1H	Evaluation Kit	1/ box

Sales Offices

The Americas

Peregrine Semiconductor Corporation

9450 Carroll Park Drive
San Diego, CA 92121
Tel: 858-731-9400
Fax: 858-731-9499

Europe

Peregrine Semiconductor Europe

Bâtiment Maine
13-15 rue des Quatre Vents
F-92380 Garches, France
Tel: +33-1-47-41-91-73
Fax : +33-1-47-41-91-73

Space and Defense Products

Americas:

Tel: 858-731-9453

Europe, Asia Pacific:

180 Rue Jean de Guiramand
13852 Aix-En-Provence Cedex 3, France
Tel: +33(0) 4 4239 3361
Fax: +33(0) 4 4239 7227

North Asia Pacific

Peregrine Semiconductor K.K.

Teikoku Hotel Tower 10B-6
1-1-1 Uchisaiwai-cho, Chiyoda-ku
Tokyo 100-0011 Japan
Tel: +81-3-3502-5211
Fax: +81-3-3502-5213

Peregrine Semiconductor, Korea

#B-2402, Kolon Tripolis, #210
Geumgok-dong, Bundang-gu, Seongnam-si
Gyeonggi-do, 463-480 S. Korea
Tel: +82-31-728-4300
Fax: +82-31-728-4305

South Asia Pacific

Peregrine Semiconductor, China

Shanghai, 200040, P.R. China
Tel: +86-21-5836-8276
Fax: +86-21-5836-7652

For a list of representatives in your area, please refer to our Web site at: www.psemi.com

Data Sheet Identification

Advance Information

The product is in a formative or design stage. The data sheet contains design target specifications for product development. Specifications and features may change in any manner without notice.

Preliminary Specification

The data sheet contains preliminary data. Additional data may be added at a later date. Peregrine reserves the right to change specifications at any time without notice in order to supply the best possible product.

Product Specification

The data sheet contains final data. In the event Peregrine decides to change the specifications, Peregrine will notify customers of the intended changes by issuing a DCN (Document Change Notice).

The information in this data sheet is believed to be reliable. However, Peregrine assumes no liability for the use of this information. Use shall be entirely at the user's own risk.

No patent rights or licenses to any circuits described in this data sheet are implied or granted to any third party.

Peregrine's products are not designed or intended for use in devices or systems intended for surgical implant, or in other applications intended to support or sustain life, or in any application in which the failure of the Peregrine product could create a situation in which personal injury or death might occur. Peregrine assumes no liability for damages, including consequential or incidental damages, arising out of the use of its products in such applications.

The Peregrine name, logo, and UTSi are registered trademarks and UltraCMOS and HaRP are trademarks of Peregrine Semiconductor Corp.

SUNSTAR 商斯达实业集团是集研发、生产、工程、销售、代理经销、技术咨询、信息服务等为一体的高科技企业，是专业高科技电子产品生产厂家，是具有 10 多年历史的专业电子元器件供应商，是中国最早和最大的仓储式连锁规模经营大型综合电子零部件代理分销商之一，是一家专业代理和分销世界各大品牌 IC 芯片和电子元器件的连锁经营综合性国际公司，专业经营进口、国产名厂名牌电子元件，型号、种类齐全。在香港、北京、深圳、上海、西安、成都等全国主要电子市场设有直属分公司和产品展示展销窗口门市部专卖店及代理分销商，已在全国范围内建成强大统一的供货和代理分销网络。我们专业代理经销、开发生产电子元器件、集成电路、传感器、微波光电元器件、工控机/DOC/DOM 电子盘、专用电路、单片机开发、MCU/DSP/ARM/FPGA 软件硬件、二极管、三极管、模块等，是您可靠的一站式现货配套供应商、方案提供商、部件功能模块开发配套商。商斯达实业公司拥有庞大的资料库，有数位毕业于著名高校——有中国电子工业摇篮之称的西安电子科技大学（西军电）并长期从事国防尖端科技研究的高级工程师为您精挑细选、量身订做各种高科技电子元器件，并解决各种技术问题。

微波光电部专业代理经销高频、微波、光纤、光电元器件、组件、部件、模块、整机；电磁兼容元器件、材料、设备；微波 CAD、EDA 软件、开发测试仿真工具；微波、光纤仪器仪表。欢迎国外高科技微波、光纤厂商将优秀产品介绍到中国、共同开拓市场。长期大量现货专业批发高频、微波、卫星、光纤、电视、CATV 器件：晶振、VCO、连接器、PIN 开关、变容二极管、开关二极管、低噪晶体管、功率电阻及电容、放大器、功率管、MMIC、混频器、耦合器、功分器、振荡器、合成器、衰减器、滤波器、隔离器、环行器、移相器、调制解调器；光电子器件和组件：红外发射管、红外接收管、光电开关、光敏管、发光二极管和发光二极管组件、半导体激光二极管和激光器组件、光电探测器和光接收组件、光发射接收模块、光纤激光器和光放大器、光调制器、光开关、DWDM 用光发射和接收器件、用户接入系统光收发器件与模块、光纤连接器、光纤跳线/尾纤、光衰减器、光纤适配器、光隔离器、光耦合器、光环行器、光复用器/转换器；无线收发芯片和模组、蓝牙芯片和模组。

更多产品请看本公司产品专用销售网站：

商斯达微波光电产品网：[HTTP://www.rfoe.net/](http://www.rfoe.net/)

商斯达中国传感器科技信息网：<http://www.sensor-ic.com/>

商斯达工控安防网：<http://www.pc-ps.net/>

商斯达电子元器件网：<http://www.sunstare.com/>

商斯达消费电子产品网：<http://www.icasic.com/>

商斯达实业科技产品网：<http://www.sunstars.cn/> 射频微波光电元器件销售热线：

地址：深圳市福田区福华路福庆街鸿图大厦 1602 室

电话：0755-83396822 83397033 83398585 82884100

传真：0755-83376182 (0) 13823648918 MSN: SUNS8888@hotmail.com

邮编：518033 E-mail:szss20@163.com QQ: 195847376

深圳赛格展销部：深圳华强北路赛格电子市场 2583 号 电话：0755-83665529 25059422

技术支持：0755-83394033 13501568376

欢迎索取免费详细资料、设计指南和光盘；产品凡多，未能尽录，欢迎来电查询。

北京分公司：北京海淀区知春路 132 号中发电子大厦 3097 号

TEL: 010-81159046 82615020 13501189838 FAX: 010-62543996

上海分公司：上海市北京东路 668 号上海赛格电子市场 D125 号

TEL: 021-28311762 56703037 13701955389 FAX: 021-56703037

西安分公司：西安高新开发区 20 所(中国电子科技集团导航技术研究所)

西安劳动南路 88 号电子商城二楼 D23 号

TEL: 029-81022619 13072977981 FAX:029-88789382