





External figure, frame material, lead pitch, lead type of each package are shown in the following chart.

< Lead Insertion Type >

Name		External outline	IC Package Description			
Symbol	Full name		Frame	Pitch	Lead type	Lead surface processing
TO-92	Transistor Outline Package		Copper Alloy	1.27mm	Single Lead	Sn-Pb plating
TO-220F	Transistor Outline Package		Copper Alloy	2.54mm		
SIP	Single In-line Package		Copper Alloy	2.54mm		
ZIP	Zig-zag In-line Package		42 Alloy	1.5mm	Dual Lead	
DIP	Dual In-line Package		Copper Alloy	2.54mm		
SDIP	Shrink Dual In-line Package		Copper Alloy	1.778mm		

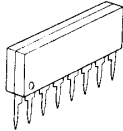
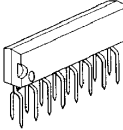
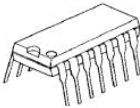
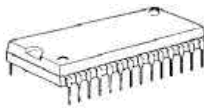

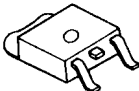





< Surface Mount Type >

Name		External outline	IC Package Description			
Symbol	Full name		Frame	Pitch	Lead type	Lead surface processing
SOT-89	Small Out-line Transistor		Copper Alloy	1.5mm	Single Flat lead	Sn-Pb plating
TO-252	Transistor Out-line Package		Copper Alloy	2.28mm	Single Gull-wing	

Note : If you can need to Pb free plating, please contact our sales department.

PACKAGE CHARACTERISTICS

< Surface Mount Type >

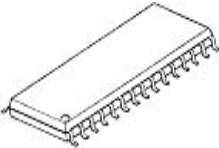
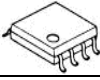
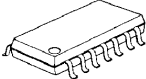
Name		External outline	IC Package Description			
Symbol	Full name		Frame	Pitch	Lead type	Lead surface processing
SON	Single Outline Non lead		Copper Alloy	0.5mm	Dual Flat Lead	Pb free Pleating
QFN	Quad Flat Non lead	-	Copper Alloy	0.4mm 0.5mm	Quad Flat Lead	Sn-Bi pleating
FLP	Flat Lead Package		Copper Alloy	0.5mm 0.65mm 0.95mm	Dual Flat Lead	Sn-Pb pleating
SC-88A			Copper Alloy	0.65mm	Dual Gull-wing	
SOT-23 (MTP)	Small Out-line Transistor		Copper Alloy	0.95mm		
TVSP	Thin Very Small Package		Copper Alloy	0.5mm 0.65mm		
VSP	Very Small Package		Copper Alloy	0.5mm 0.65mm		
SSOP	Shrink Small Outline Package		42 Alloy	0.5mm 0.65mm 0.8mm		
DMP	Dual In-line Mini Mold Package		42 alloy * 24pin Copper Alloy	0.95mm 2.54mm		
SDMP	Shrink Dual In-line Mini Mold Package		Copper Alloy	1.0mm		
EMP	DMP (JEDEC)		Copper Alloy	1.27mm		
SOP	Small Out-line Package		42Alloy * 28pin Cu Alloy 42 Alloy	1.27mm		

Note : If you can need to Pb free pleating, please contact our sales department.

PACKAGE CHARACTERISTICS

< Surface Mount Type >

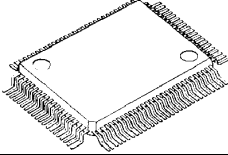
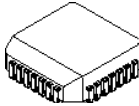
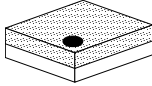
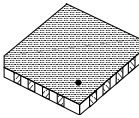
Name		External Outline	IC Package Description			
Symbol	Full name		Frame	Pitch	Lead type	Lead surface processing
QFP	Quad Flat Package		Copper Alloy	0.5mm 0.65mm 0.8mm 1.0mm	Quad Gull-wing	Sn-Pb pleating
PLCC	Plastic Lead Chip Carrier		Copper Alloy	1.27mm	Quad J-Lead	
PCSP	Plastic Chip Size Package		Inter Poser (organic Substrate)	0.5mm 0.65mm	LGA with Stand off	Au pleating
FFP	Flip-chip Fine Package		Inter Poser (Ceramic Substrate)	0.5mm	Combined Bottom and Side wall Terminals	

Note : If you can need to Pb free pleating, please contact our sales department.

< Tape Carrier Package >

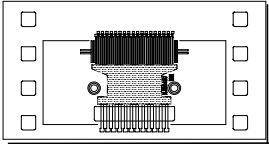
Name		External outline	IC Package Description			
Symbol	Full name		Frame	Pitch	Lead type	Lead surface processing
TCP	Tape Carrier Package		-	-	-	Sn Au Sn-Au