

## FDD READ AMPLIFIER SYSTEM

### ■ GENERAL DESCRIPTION

The **NJM3470/3470A** are monolithic read amplifier systems for obtaining digital signal from floppy disk storage.

The **NJM3470/3470A** are designed to get pulse output signal produced by the magnetic head amp of the input signal. They contain amplifiers, peak detector, and pulse shape circuit. They are classified two ranks by peak shift characteristic; **NJM3470** (5%), **NJM3470A** (2%).

### ■ PACKAGE OUTLINE

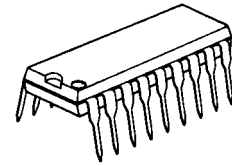

**NJM3470D/3470AD**

### ■ FEATURES

- Gain Adjustable (5MHz min. @-3dB)
- Wide Bandwidth (A-rank : 2%max.)
- Peak Shift (DIP18)
- Package Outline
- Bipolar Technology

### ■ PIN CONFIGURATION

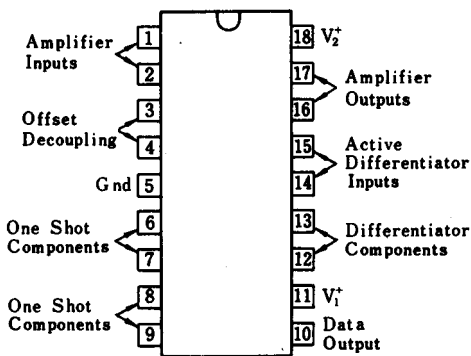

**NJM3470D/3470AD**

### ■ BLOCK DIAGRAM

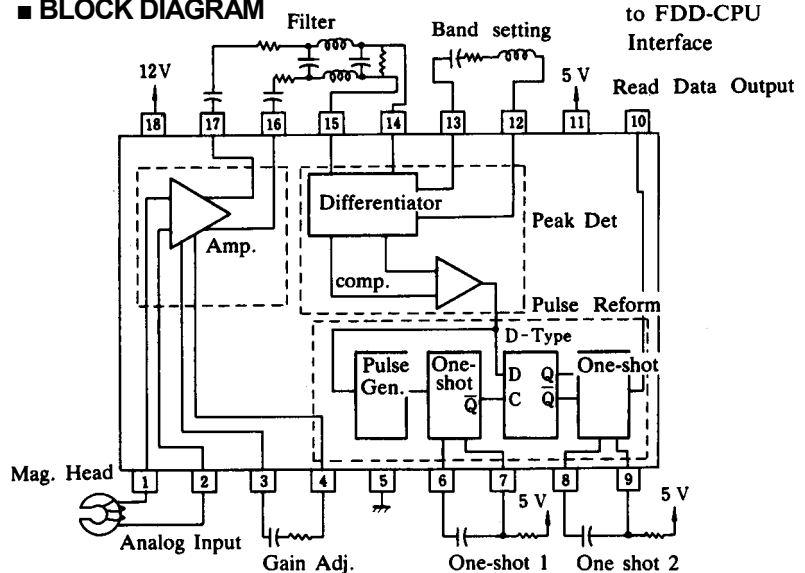

**NJM3470 BLOCK DIAGRAM  
and  
STANDARD OUTPUT CIRCUIT**

### ■ ABSOLUTE MAXIMUM RATINGS

( $T_a = 25^\circ\text{C}$ )

PARAMETER	SYMBOL	RATINGS	UNIT
Supply Voltage I (Pin 11)	$V_1^+$	7	V
Supply Voltage II (Pin 18)	$V_2^+$	16	V
Input Voltage (Pin 1-2)	$V_{IN}$	-0.2 to 7.0	V
Output Voltage (Pin 10)	$V_O$	-0.2 to 7.0	V
Operating Temperature Range	$T_{opr}$	-20 to +75	$^\circ\text{C}$
Storage Temperature Range	$T_{stg}$	-40 to +125	$^\circ\text{C}$

# NJM3470/3470A

## ■ ELECTRICAL CHARACTERISTICS

(Ta = 25°C, V<sub>1</sub><sup>+</sup> = 5V, V<sub>2</sub><sup>+</sup> = 12V) note: ( ) apply to A-rank.

### Amplifier Block

PARAMETER	SYMBOL	TEST CONDITION	MIN.	TYP.	MAX.	UNIT
Differential Voltage Gain	A <sub>VD</sub>	f = 200kHz, V <sub>ID</sub> = 5.0mVrms	80 (100)	100 (110)	120 (120)	V/V
Input Bias Current	I <sub>IB</sub>		-	-10	-25	μA
Input Common Mode Range	V <sub>ICM</sub>	THD = 5%	-0.1	-	1.0	V
Differential Input Voltage Range	V <sub>ID</sub>	THD = 5%	-	-	25	mV <sub>P-P</sub>
Output Voltage Swing Differential	V <sub>OD</sub>		3.0	4.0	-	V <sub>P-P</sub>
Output Source Current	I <sub>SOURCE</sub>		-	8.0	-	mA
Output Sink Current	I <sub>SINK</sub>		2.8	4.0	-	mA
Small Signal Input Resistance	r <sub>i</sub>		100	250	-	kΩ
Small Signal Output Resistance	r <sub>o</sub>		-	15	-	Ω
Bandwidth, -3.0dB	BW	V <sub>ID</sub> = 2.0mVrms	5.0	-	-	MHz
Common Mode Rejection Ratio	CMR	f=100kHz, A <sub>VD</sub> = 40dB, V <sub>in</sub> = 200mV <sub>P-P</sub>	50	-	-	dB
Supply Voltage Rejection Ratio (V <sub>1</sub> <sup>+</sup> )	SVRR <sub>1</sub>	A <sub>VD</sub> = 40dB, 4.75 ≤ V <sub>1</sub> <sup>+</sup> ≤ 5.25V	50	-	-	dB
Supply Voltage Rejection Ratio (V <sub>2</sub> <sup>+</sup> )	SVRR <sub>2</sub>	A <sub>VD</sub> = 40dB, 10 ≤ V <sub>2</sub> <sup>+</sup> ≤ 14V	60	-	-	dB
Differential Output Offset	V <sub>DO</sub>	V <sub>ID</sub> = V <sub>IN</sub> = 0V	-	-	0.4	V
Common Mode Output Offset	V <sub>CO</sub>	V <sub>ID</sub> = V <sub>IN</sub> = 0V	-	3.0	-	V
Equivalent Input Noise Voltage	e <sub>n</sub>	BW = 10Hz to 1.0MHz	-	15	-	μVrms

### Peak Detector Block

PARAMETER	SYMBOL	TEST CONDITION	MIN.	TYP.	MAX.	UNIT
Differentiator Output Sink Current	I <sub>OD</sub>	V <sub>OD</sub> = 5V	1.0	1.4	-	mA
Peak Shift	PS	f = 250kHz, V <sub>ID</sub> = 1.0V <sub>P-P</sub> , i <sub>cap</sub> = 500μA PS = (t <sub>PS1</sub> - t <sub>PS2</sub> ) / 2 (t <sub>PS1</sub> + t <sub>PS2</sub> ) x 100			5.0 (2.0)	% %
Differentiator Input Resistance, Differential	r <sub>ID</sub>		-	30	-	kΩ
Differentiator Output Resistance, Differential	r <sub>OD</sub>		-	40	-	Ω

### Logic Block

PARAMETER	SYMBOL	TEST CONDITION	MIN.	TYP.	MAX.	UNIT
Timing Accuracy (mono #1)	E <sub>t1</sub>	t <sub>1</sub> = 1.0μS = 0.625R <sub>1</sub> C <sub>1</sub> + 200nS R <sub>1</sub> = 6.4kΩ C <sub>1</sub> = 200pF (accuracy : R <sub>1</sub> , C <sub>1</sub> ) 1.5kΩ ≤ R <sub>1</sub> ≤ 10 kΩ 150pF ≤ C <sub>1</sub> ≤ 680pF	85	-	115	%
Timing Range (mono #2)	t <sub>2</sub>		150	-	1000	nS
Timing Accuracy (mono #2)	E <sub>t2</sub>	t <sub>2</sub> = 200nS = 0.625R <sub>2</sub> C <sub>2</sub> R <sub>2</sub> = 1.6 kΩ C <sub>2</sub> = 200pF (accuracy; R <sub>2</sub> , C <sub>2</sub> ) 1.5 kΩ ≤ R <sub>2</sub> ≤ 10 kΩ 100pF ≤ C <sub>2</sub> ≤ 800pF	85	-	115	%

**[CAUTION]**

The specifications on this databook are only given for information, without any guarantee as regards either mistakes or omissions. The application circuits in this databook are described only to show representative usages of the product and not intended for the guarantee or permission of any right including the industrial rights.