

TV VIDEO MODULATOR

■ GENERAL DISCRIPTION

The **NJM2208**, an integrated circuit used to generate an RF TV signal from baseband color-difference and luminance signals.

The **NJM2208** contains a chroma subcarrier oscillator, 3.58MHz oscillator, 4.5MHz oscillator, 3.58MHz lead and lag network, an RF oscillator, sound carrier oscillator, and a TTL compaible clock driver with adjustable duty cycle.

This device may also be used as a general-purpose modulator with a variety of video signal generating devices such as video games, test equipment, video tape recorders, etc.

■ PACKAGE OUTLINE

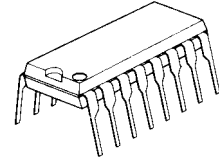

NJM2208D

■ FEATURES

- Operating Voltage (+4.75V to +5.25V)
- Acts by Digital Control Signal
- Single 5.0 Vdc Supply Operation for NMOS and TTL Compatibility
- Minimal External Components
- Low Power Dissipation
- Linear Chroma Modulators for High Versatility
- Composite Video Signal Generation Capability
- Ground-Referenced Video Prevents Overmodulation
- Internal Sound Carrier Oscillator
- Video Signal Encoder Capability
- Package Outline DIP16
- Bipolar Technology

■ PIN CONFIGURATION

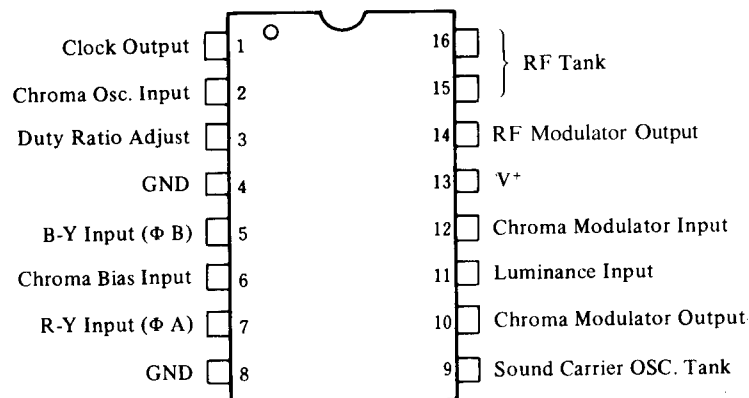

NJM2208D

NJM2208

■ ABSOLUTE MAXIMUM RATINGS

(T_a=25°C)

PARAMETER	SYMBOL	RATINGS	UNIT
Supply Voltage	V ⁺	8	V
Power Dissipation	P _D	700	mW
Operating Temperature Range	T _{opr}	-20 to +75	°C
Storage Temperature Range	T _{stg}	-40 to +125	°C

■ ELECTRICAL CHARACTERISTICS

(T_a=25°C)

PARAMETER	SYMBOL	TEST CONDITION	MIN.	TYP.	MAX.	UNIT
Operating Voltage	V ⁺		4.75	5.0	5.25	V
Operating Current	I _{CC}		-	26	-	mA

Chroma Oscillator/Clock Driver/Sound Oscillator (Test Circuit 1)

Chroma Output Voltage	V _{OL}		-	-	0.4	V
Chroma Output Voltage	V _{OH}		2.4	-	-	V
Rise Time	t _r	0.4→2.4V	-	-	50	ns
Fall Time	t _f	2.4→0.4V	-	-	50	ns
Duty Cycle Adjustment Range	V _{aj}	Threshold Voltage V ₁ =1.4V, V ₃ =1.2 to 5V	40	-	60	%
Inherent Duty Cycle	V _{OD}		-	50	-	%
Sound Oscillator Output Voltage	V _{SO}	Pin 9 SW 1 ON	3.0	4.0	5.0	V _{P-P}

Chroma Modulator (Test Circuit 1)

Input Common Mode Voltage Range		Pin 5, 6, 7	0.8	-	2.3	V
Oscillator Feedthrott	CL	Pin 10	-	15	31	mV
Modulation Angle	Cθ	θ ₁₀ (V ₇ =2.0V)-θ ₁₀ (V ₅ =2.0V)	85	100	115	degree
Conversion Gain	G _{CC}	V ₁₀ /(V ₇ -V ₆) : V ₁₀ /(V ₅ -V ₆)	-	0.6	-	V _{P-P} /V
Input Current	I _i	Pin 5, 6, 7	-	-	-20	μA
Input Resistance	R _i	Pin 5, 6, 7	100	-	-	kΩ
Input Capacitance	C _i	Pin 5, 6, 7	-	-	5	pF
Chroma Modulator Linearity	L _{cm}	Pin 10 ; V ₅ =1→2V ; V ₇ =1→2V	-	4.0	6	%

RF Modulator (Test Circuit 2)

Luma Input Dynamic Range		Pin 11 (TC2)	0	-	1.5	V
RF Output Voltage	V _{RF}	f=67.25MHz, V ₁₁ =1.0V (TC1)	15	30	-	mVrms
Luminance	G _{LV}	(ΔV ₁₄ /ΔV ₁₁ : V ₁₁ =0.1→1.0V) (TC2)	0.5	0.7	-	V/V
Chroma Conversion Gain	G _{CV}	(ΔV ₁₄ /ΔV ₁₂ : V ₁₂ =1.5V _{PP} , V ₁₁ =1.0V) (TC2)	0.7	0.9	1.2	V/V
Chroma Linearity	L _C	Pin 14 V ₁₂ =1.5V _{PP} (TC2)	-	1.0	4.0	%
Luminance	L _L	Pin 14 V ₁₁ =0→1.5V (TC2)	-	2.0	5.0	%
Input Current	I _i	Pin 11	-	-	-20	μA
Input Resistance	R _i	Pin 12	-	800	-	Ω
Input Resistance	R _i	Pin 11	100	-	-	kΩ
Input Capacitance	C _i	Pin 11, 12	-	-	5	pF
Output Current	I _o	Pin 14 (TC2)	-	0.9	-	mA
Residual 920kHz	B	Pin 14 V ₁₁ =1V (TC1 SW1 ON) V _C =300mV _{PP} /3.58MHz V _S =250mV _{PP} /4.5MHz	-	50	-	dB

TEST CIRCUIT 1

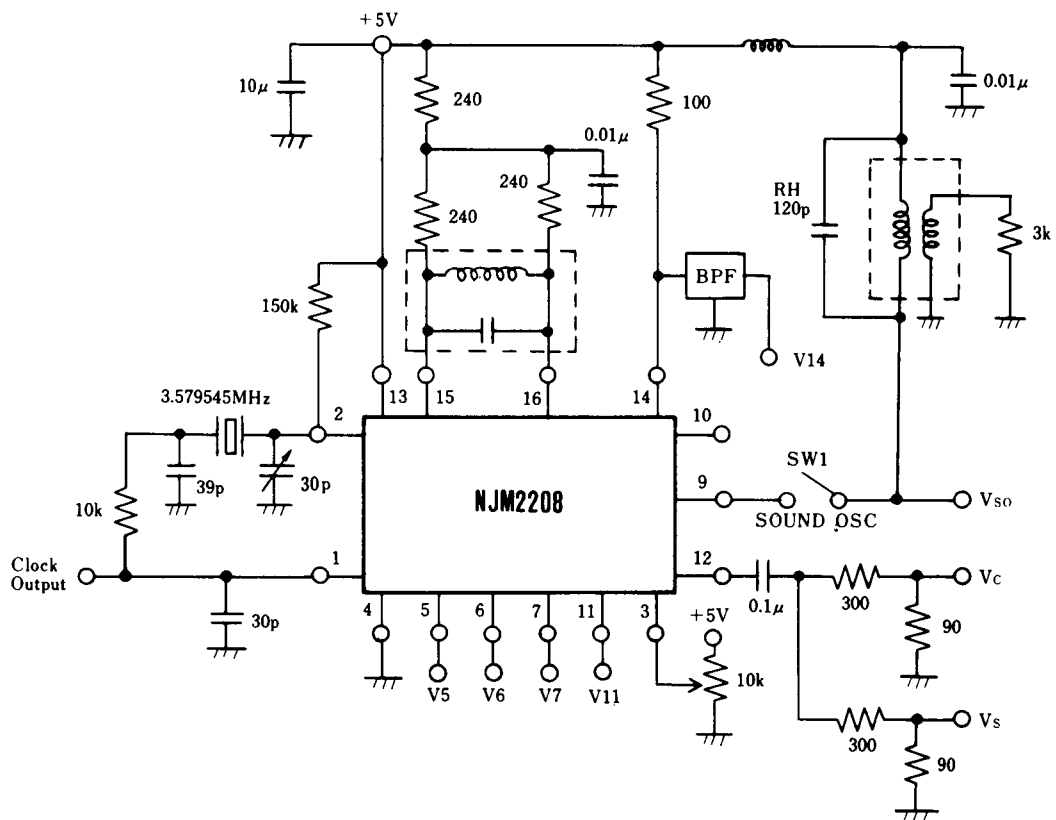

TEST CIRCUIT 2

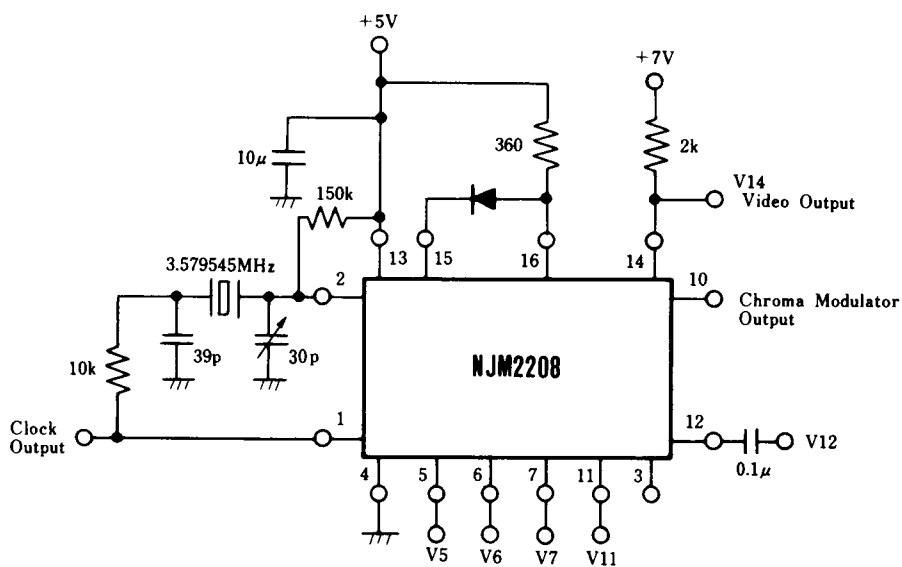

NJM2208

■ DESCRIPTION OF OPERATION

NJM2208 produces color difference signals and luminance signal from microcomputer output signals RGB, clock, and hold signals through the matrix circuit, and also produces the TV RF signal or video base band signal. Sound Carrier Input is also added to this IC, and a color TV RF modulator is composed by adding the video and sound carrier tank LC and crystal oscillator.

● Properties of TV waves

Fig. 2 shows the frequency band of TV RF signal. The band width of this signal is 6MHz, in which video signals (luminance signal and synchronous signals) are distributed with a video carrier wave of 4MHz. As a result, coarse images appear at about 0Hz, while fine images appear at about 4MHz. The color signals are distributed over a range of $3.58\text{MHz} \pm 500\text{kHz}$ from the color carrier. These signals are not included in monochromatic images, of course.

The color signals conduct the perpendicular 2-phase modulation with suppressed carrier in order to avoid the interference with the video signals. Unlike in AM and FM systems, this system modulates the color signals with the color difference signals obtained by deviating the carrier phase by 90° .

The TV sound carrier signal is distributed over a range of $4.5\text{MHz} \pm 25\text{kHz}$ late, the color signals are phase-modulated, and the sound carrier signal is FM-modulated in one channel, these signals overlap each other in narrow band to be compatible with monochromatic TV, causing the TV waves to be complicated.

● RF modulator for color TV

Fig. 3 shows the basic operation circuit of NJM2208. Now, the operation will be described according to the production sequence of broadcast waves. A 3.58MHz color carrier is oscillated by a crystal oscillator at pins 1 and 2. This output (Pin 1) can be led as a microcomputer clock. Higher harmonic components are removed from this square waveform through a BPF (bandpass filter).

Then two signals are produced from a 3.58MHz sine wave. Of these signals, the LEAD signal is obtained by leading the phase by 45° , while the LAG signal is obtained by lagging the phase by 45° from the carrier phase by the CR constant in the IC, respectively. On the other hand, the color signals RGB are converted into two color difference signals E_{B-Y} and E_{R-Y} by the matrix circuit, and applied to pins 5 and 7. The LEAD wave is modulated and added by E_{B-Y} , while the LAG wave is modulated and added by E_{R-Y} . These chroma-modulated signals are output to pin 10. photo 1 shows the relationship between the color difference signals and the modulation output in case of color bars (TV quasei signal generation).

A sound carrier 4.5MHz is oscillated by L_1 connected to pin 9, and FM-modulated by the audio signal. Accordingly, a VHF (2ch) is oscillated in the LC tank circuit of pins 15 and 16 by inputting the color and sound modulation signals to pin 12 and also color luminance signals to pin 11, and the differential transistors in IC are switched by the VHF voltage to generate an RF signal by the AM modulation. Photo 2 shows individual waveforms.

The RF signal is obtained through 75Ω to match the TV antenna impedance. Photo 3 indicates the RF signal with the sound carrier signal super imposed.

Since signals are present in the VHF band, the PCB patterns should be not long at pins 15 and 16, and a bypass capacitor should be connected to the power supply without fail. In addition, three oscillation signals should be isolated enough from each other with a sufficient mounting section interval.

● Application to base band output

This IC can also be taken as the video base band output as well as the RF output. In order to convert the RGB output signals from the microcomputer into the color difference signals and luminance signal, they are converted by the matrix circuit and connected to the color input terminals of NJM2208. This IC serves as a color encoder. TV images become clear, because neither RF modulation nor RF demodulation is done. For this purpose, remove the LC from pins 15 and 16, and connect the diode instead, so that the differential voltage in IC is fixed to drive IC as an amplifier.

An 1k Ω video signal is obtained. However, since this video signal output voltage is low and its output impedance is high, the video signal is amplified through an operational amplifier.

(Fig. 1) Application of video RF modulator (color encoder IC)

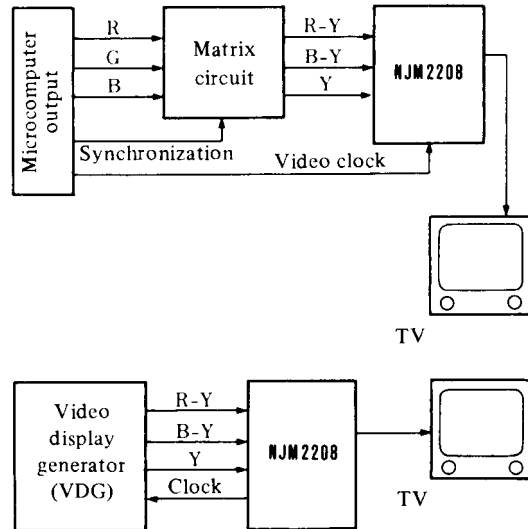

(Fig. 2) Frequency Spectrum In TV Wave

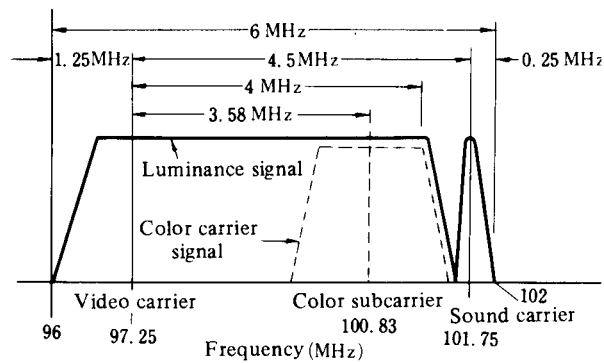

NJM2208

Fig. 3 MODULATOR FOR COLOR TV.

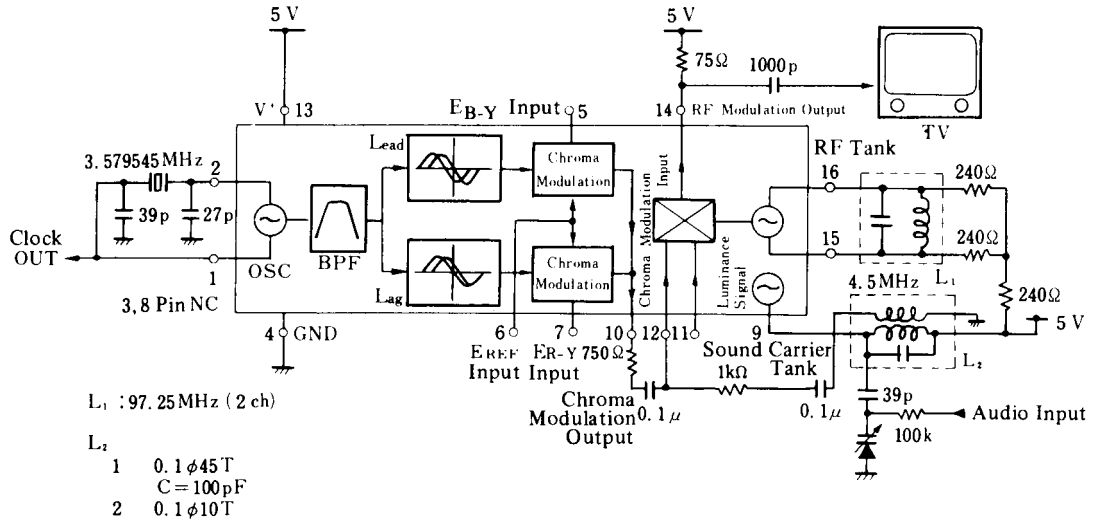

Fig. 4 APPLICATION OF BASE-BAND OUTPUT

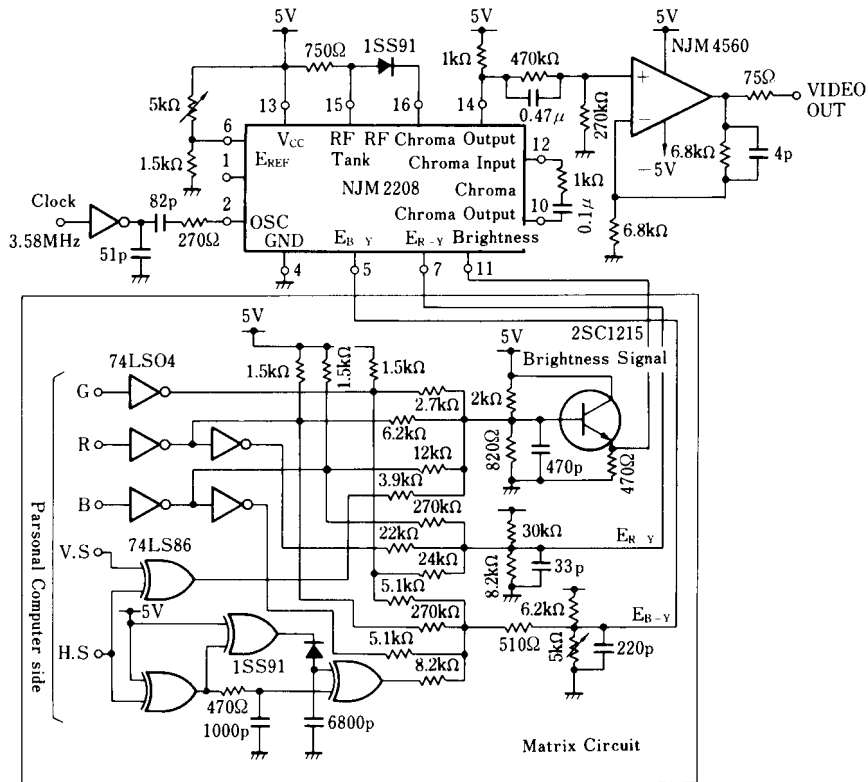

Photo-1 color difference Signals and Modulation Output by Color Bar

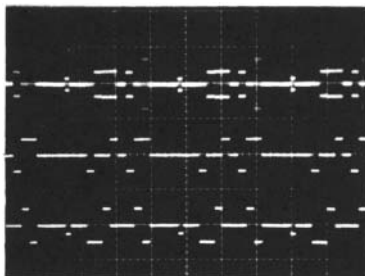

Photo-2 Video Luminance Signal and RF Output

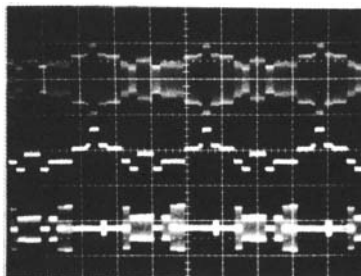
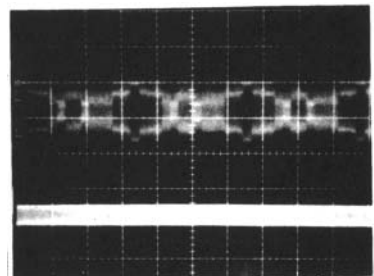

Photo-3 RF Output with Sound Carrier Signal Superimposed



[CAUTION]

The specifications on this databook are only given for information, without any guarantee as regards either mistakes or omissions. The application circuits in this databook are described only to show representative usages of the product and not intended for the guarantee or permission of any right including the industrial rights.