

STEPPER MOTOR DRIVER

■ GENERAL DESCRIPTION

NJM3717 is a stepper motor driver, which consists of a LS-TTL compatible logic input stage, a current sensor, a monostable multivibrator and a high power H-bridge output stage with built-in protection diodes.

The output current is up to 1200mA. Two NJM3717 and a small number of external components form a complete control and drive unit for stepper motor systems.

■ FEATURES

- Half-step and full-step modes
- Switched mode bipolar constant current drive
- Wide range of current control 5 - 1200 mA
- Wide voltage range 10 - 50 V
- Thermal overload protection
- Packages DIP16 / PLCC28 / EMP20

■ PACKAGE OUTLINE

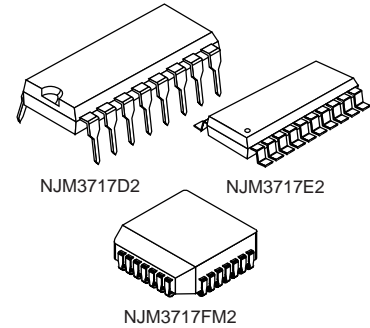

■ BLOCK DIAGRAM

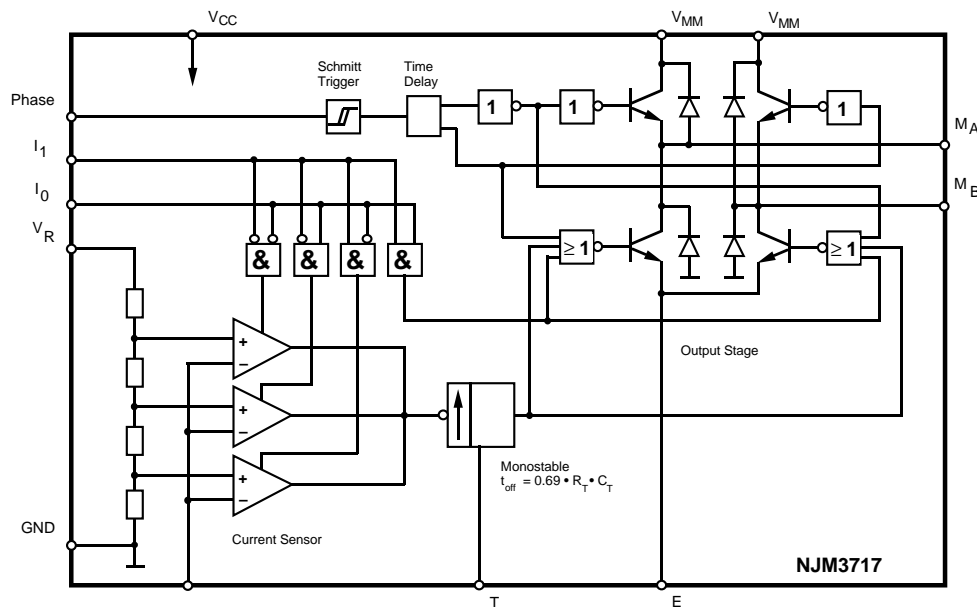

Figure 1. Block diagram

■ PIN CONFIGURATIONS

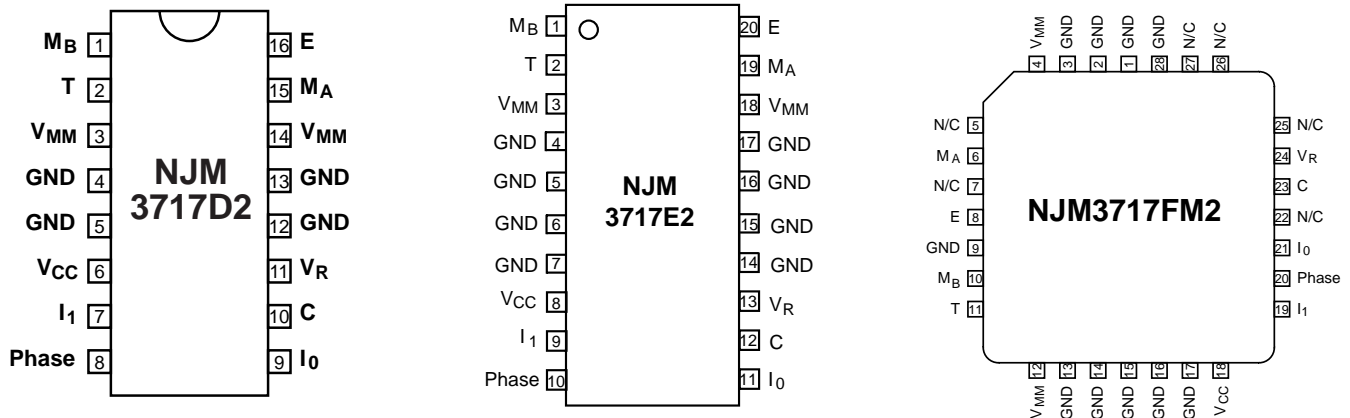

Figure 2. Pin configurations

■ PIN DESCRIPTION

DIP	EMP	PLCC	Symbol	Description
1	1	10	M_B	Motor output B, Motor current flows from M_A to M_B when Phase is high.
2	2	11	T	Clock oscillator. Timing pin connect a 56 k Ω resistor and a 820 pF in parallel between T and Ground.
3,14	3,18	12,4	V_{MM}	Motor supply voltage, 10 to 45 V. V_{MM} pins should be wired together on PCB.
4,5,12,13	4,5,6,7,14,15,16,17	1,2,3,9,13,14,15,16,17,28	GND	Ground and negative supply. Note these pins are used for heatsinking. Make sure that all ground pins are soldered onto a suitable large copper ground plane for efficient heat sinking.
6	8	18	V_{CC}	Logic voltage supply normally +5 V.
7	9	19	I_1	Logic input, it controls, together with the I_0 input, the current level in the output stage. The controllable levels are fixed to 100, 60, 20, 0%.
8	10	20	Phase	Controls the direction of the motor current of M_A and M_B outputs. Motor current flows from M_A to M_B when the phase input is high.
9	11	21	I_0	Logic input, it controls, together with the I_1 input, the current level in the output stage. The controlable levels are fixed to 100, 60, 20, 0%.
10	12	23	C	Comparator input. This input senses the instantaneous voltage across the sensing resistor, filtered through a RC Network.
11	13	24	V_R	Reference voltage. Controls the threshold voltage of the comparator and hence the output current. Input resistance: typically 6.8k $\Omega \pm 20\%$.
15	19	6	M_A	Motor output A, Motor current flows from M_A to M_B when Phase is high.
16	20	8	E	Common emitter. Connect the sense resistor between this pin and ground.

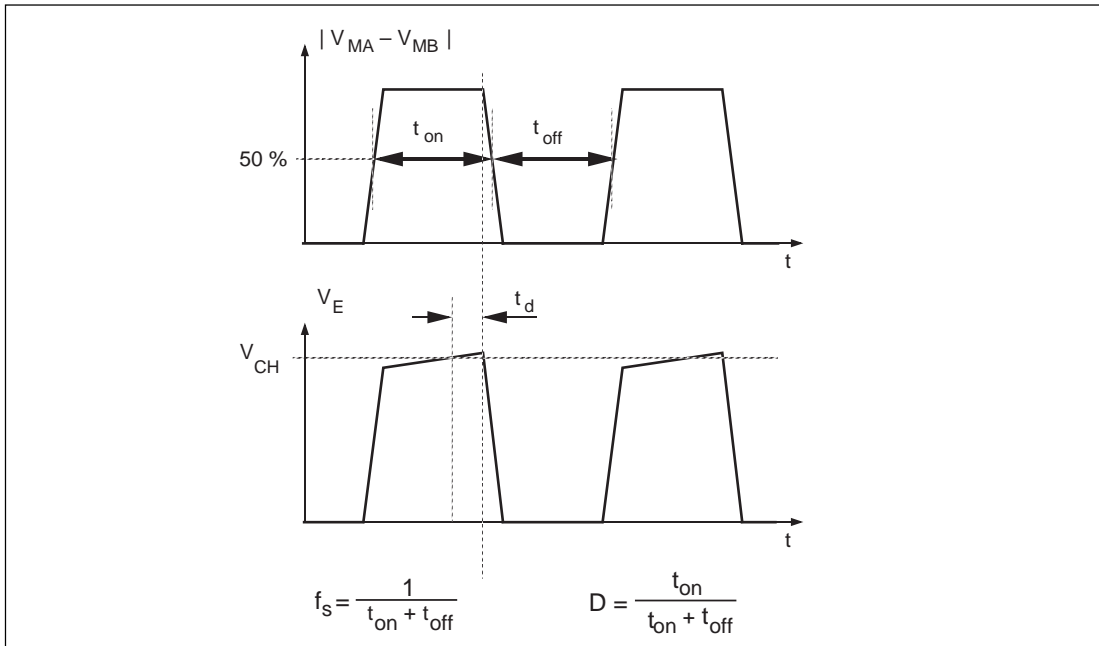

Figure 3. Definition of terms

■ FUNCTIONAL DESCRIPTION

The NJM3717 is intended to drive a bipolar constant current through one motor winding of a 2-phase stepper motor.

Current control is achieved through switched-mode regulation, see figure 4 and 5.

Three different current levels and zero current can be selected by the input logic.

The circuit contains the following functional blocks:

- Input logic
- Current sense
- Single-pulse generator
- Output stage

Input logic

Phase input. The phase input determines the direction of the current in the motor winding. High input forces the current from terminal M_A to M_B and low input from terminal M_B to M_A. A Schmitt trigger provides noise immunity and a delay circuit eliminates the risk of cross conduction in the output stage during a phase shift.

Half- and full-step operation is possible.

Current level selection. The status of I₀ and I₁ inputs determines the current level in the motor winding. Three fixed current levels can be selected according to the table below.

Motor current	I ₀	I ₁
High level	100% L	L
Medium level	60% H	L
Low level	20% L	H
Zero current	0% H	H

The specific values of the different current levels are determined by the reference voltage V_R together with the value of the sensing resistor R_S.

The peak motor current can be calculated as follows:

$$i_m = (V_R \cdot 0.083) / R_S \text{ [A], at 100% level}$$

$$i_m = (V_R \cdot 0.050) / R_S \text{ [A], at 60% level}$$

$$i_m = (V_R \cdot 0.016) / R_S \text{ [A], at 20% level}$$

The motor current can also be continuously varied by modulating the voltage reference input.

Current sensor

The current sensor contains a reference voltage divider and three comparators for measuring each of the selectable current levels. The motor current is sensed as a voltage drop across the current sensing resistor, R_S , and compared with one of the voltage references from the divider. When the two voltages are equal, the comparator triggers the single-pulse generator. Only one comparator at a time is activated by the input logic.

Single-pulse generator

The pulse generator is a monostable multivibrator triggered on the positive edge of the comparator output. The multivibrator output is high during the pulse time, t_{off} , which is determined by the timing components R_T and C_T .

$$t_{off} = 0.69 \cdot R_T \cdot C_T$$

The single pulse switches off the power feed to the motor winding, causing the winding to decrease during t_{off} . If a new trigger signal should occur during t_{off} , it is ignored.

Output stage

The output stage contains four transistors and four diodes, connected in an H-bridge. The two sinking transistors are used to switch the power supplied to the motor winding, thus driving a constant current through the winding. See figures 4 and 5.

Overload protection

The circuit is equipped with a thermal shut-down function, which will limit the junction temperature. The output current will be reduced if the maximum permissible junction temperature is exceeded. It should be noted, however, that it is not short circuit protected.

Operation

When a voltage V_{MM} is applied across the motor winding, the current rise follows the equation:

$$i_m = (V_{MM} / R) \cdot (1 - e^{-(R \cdot t) / L})$$

R = Winding resistance

L = Winding inductance

t = time

(see figure 5, arrow 1)

The motor current appears across the external sensing resistor, R_S , as an analog voltage. This voltage is fed through a low-pass filter, $R_C C_C$, to the voltage comparator input (pin 10). At the moment the sensed voltage rises above the comparator threshold voltage, the monostable is triggered and its output turns off the conducting sink transistor.

The polarity across the motor winding reverses and the current is forced to circulate through the appropriate upper protection diode back through the source transistor (see figure 5, arrow 2).

After the monostable has timed out, the current has decayed and the analog voltage across the sensing resistor is below the comparator threshold level.

The sinking transistor then closes and the motor current starts to increase again. The cycle is repeated until the current is turned off via the logic inputs.

By reversing the logic level of the phase input (pin 8), both active transistors are turned off and the opposite pair turned on after a slight delay. When this happens, the current must first decay to zero before it can reverse. This current decay is steeper because the motor current is now forced to circulate back through the power supply and the appropriate sinking transistor protection diode. This causes higher reverse voltage build-up across the winding which results in a faster current decay (see figure 5, arrow 3).

For best speed performance of the stepper motor at half-step mode operation, the phase logic level should be changed at the same time the current-inhibiting signal is applied (see figure 6).

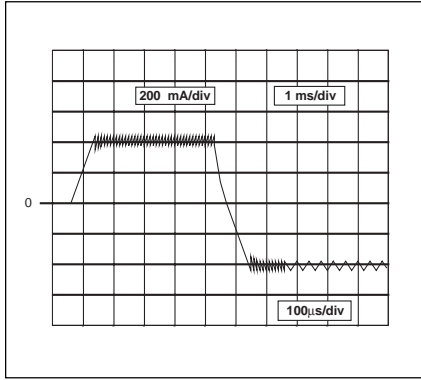

Figure 4. Motor current (I_M), Vertical : 200 mA/div, Horizontal: 1 ms/div, expanded part 100 μs/div

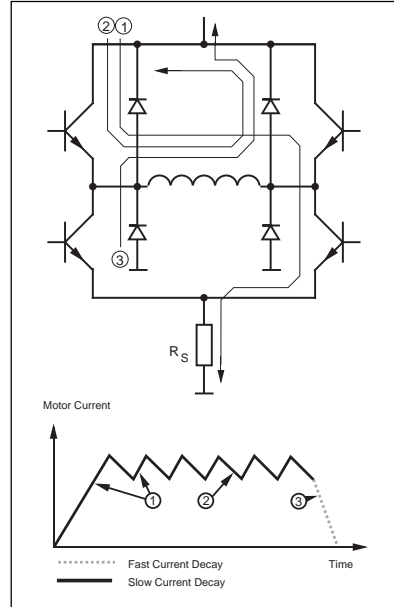

Figure 5. Output stage with current paths for fast and slow current decay

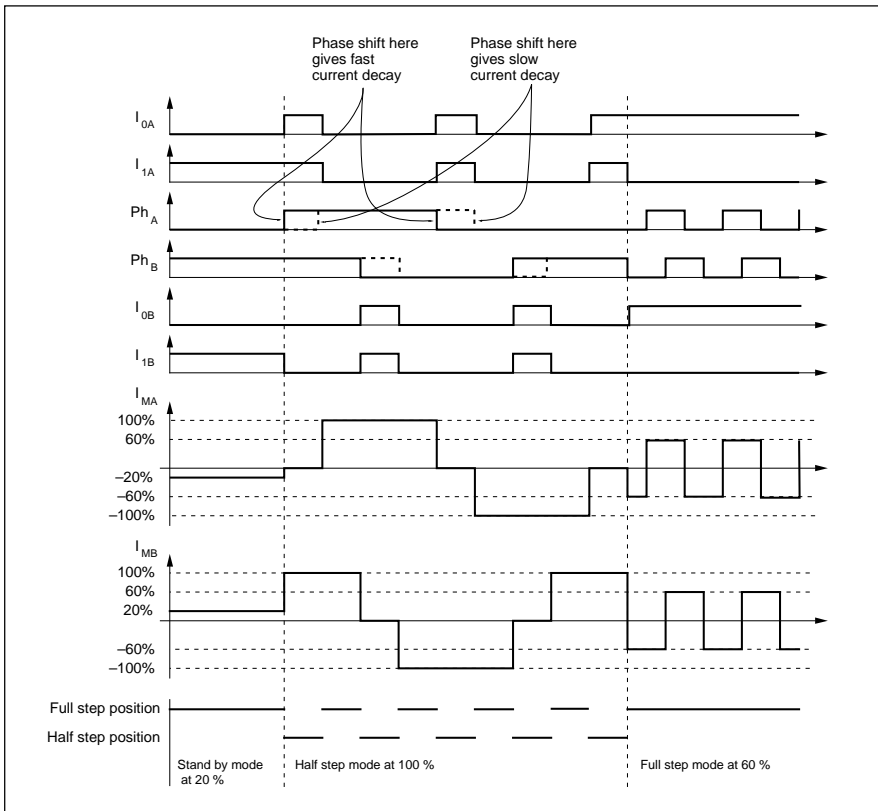

Figure 6. Principal operating sequence

■ ABSOLUTE MAXIMUM RATINGS

Parameter	Pin [DIP]	Symbol	Min	Max	Unit
Voltage					
Logic supply	6	V_{CC}	0	7	V
Motor supply	3, 14	V_{MM}	0	50	V
Logic inputs	7, 8, 9	V_I	-0.3	6	V
Comparator input	10	V_C	-0.3	V_{CC}	V
Reference input	11	V_R	-0.3	15	V
Current					
Motor output current	1, 15	I_M	-1200	+1200	mA
Logic inputs	7, 8, 9	I_I	-10	-	mA
Analog inputs	10, 11	I_A	-10	-	mA
Temperature					
Operating junction temperature		T_j	-40	+150	°C
Storage temperature		T_{stg}	-55	+150	°C

■ RECOMMENDED OPERATING CONDITIONS

Parameter	Symbol	Min	Typ	Max	Unit
Logic supply voltage	V_{CC}	4.75	5	5.25	V
Motor supply voltage	V_{MM}	10	-	45	V
Motor output current	I_M	-1000	-	+1000	mA
Operating junction temperature	T_j	-20	-	+125	°C
Rise time logic inputs	t_r	-	-	2	μs
Fall time logic inputs	t_f	-	-	2	μs

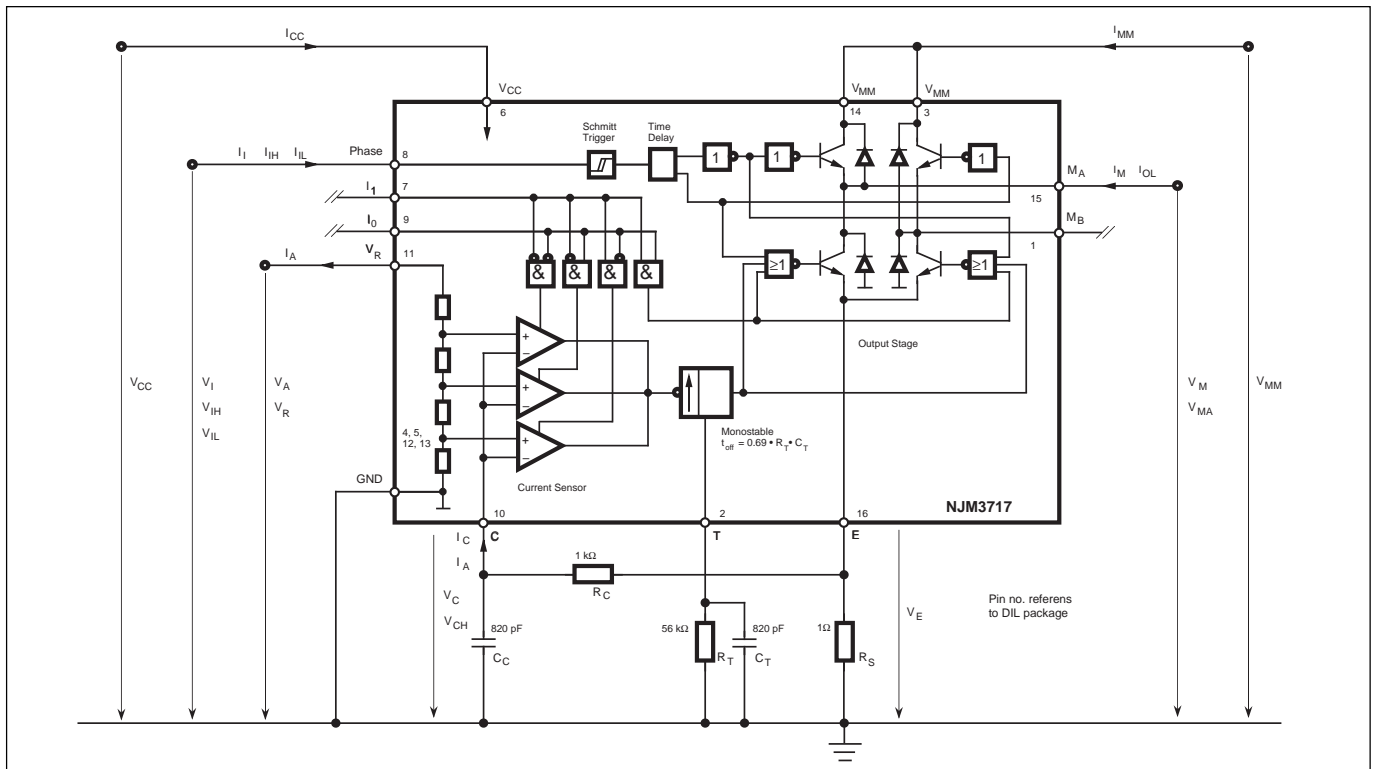

Figure7. Definition of symbols

■ ELECTRICAL CHARACTERISTICS

Electrical characteristics over recommended operating conditions, unless otherwise noted $-20^{\circ}\text{C} \leq T_J \leq +125^{\circ}\text{C}$.

$C_T = 820 \text{ pF}$, $R_T = 56 \text{ kohm}$.

Parameter	Symbol	Conditions	Min	Typ	Max	Unit
General						
Supply current	I_{CC}		-	-	25	mA
Total power dissipation	P_D	$f_s = 28 \text{ kHz}$, $I_M = 500\text{mA}$, $V_{MM} = 36 \text{ V}$ Note 2, 4.	-	1.4	1.7	W
		$f_s = 28 \text{ kHz}$, $I_M = 800\text{mA}$, $V_{MM} = 36 \text{ V}$ Note 3, 4.	-	2.8	3.3	W
Turn-off delay	t_d	$T_a = +25^{\circ}\text{C}$, $dV_C/dt \geq 50 \text{ mV}/\mu\text{s}$.	-	0.9	1.5	μs
Thermal shutdown junction temperature			-	170	-	$^{\circ}\text{C}$
Logic Inputs						
Logic HIGH input voltage	V_{IH}		2.0	-	-	V
Logic LOW input voltage	V_{IL}		-	-	0.8	V
Logic HIGH input current	I_{IH}	$V_I = 2.4 \text{ V}$	-	-	20	μA
Logic LOW input current	I_{IL}	$V_I = 0.4 \text{ V}$	-0.4	-	-	mA
Reference Input						
Input resistance	R_R	$T_a = +25^{\circ}\text{C}$	-	6.8	-	kohm
Comparator Inputs						
Threshold voltage	V_{CH}	$V_R = 5.0 \text{ V}$, $I_0 = I_1 = \text{LOW}$	400	415	430	mV
Threshold voltage	V_{CM}	$V_R = 5.0 \text{ V}$, $I_0 = \text{HIGH}$, $I_1 = \text{LOW}$	240	250	265	mV
Threshold voltage	V_{CL}	$V_R = 5.0 \text{ V}$, $I_0 = \text{LOW}$, $I_1 = \text{HIGH}$	70	80	90	mV
Input current	I_C		-20	-	-	μA
Motor Outputs						
Lower transistor saturation voltage		$I_M = 500 \text{ mA}$	-	0.9	1.2	V
		$I_M = 800 \text{ mA}$	-	1.1	1.4	V
Lower diode forward voltage drop		$I_M = 500 \text{ mA}$	-	1.2	1.5	V
		$I_M = 800 \text{ mA}$	-	1.3	1.7	V
Upper transistor saturation voltage		$I_M = 500 \text{ mA}$	-	1.0	1.25	V
		$I_M = 800 \text{ mA}$	-	1.2	1.5	V
Upper diode forward voltage drop		$I_M = 500 \text{ mA}$	-	1.0	1.25	V
		$I_M = 800 \text{ mA}$	-	1.2	1.45	V
Output leakage current		$I_0 = I_1 = \text{HIGH}$, $T_a = +25^{\circ}\text{C}$	-	-	100	μA
Monostable						
Cut off time	t_{off}	$V_{MM} = 10 \text{ V}$, $t_{on} \geq 5 \mu\text{s}$	27	31	35	μs

■ THERMAL CHARACTERISTICS

Parameter	Symbol	Conditions	Min	Typ	Max	Unit
Thermal resistance	$R_{thj-GND}$	DIP package.	-	11	-	$^{\circ}\text{C}/\text{W}$
	R_{thj-A}	DIP package. Note 2.	-	40	-	$^{\circ}\text{C}/\text{W}$
	$R_{thj-GND}$	PLCC package.	-	9	-	$^{\circ}\text{C}/\text{W}$
	R_{thj-A}	PLCC package. Note 2.	-	35	-	$^{\circ}\text{C}/\text{W}$
	$R_{thj-GND}$	EMP package	-	11	-	$^{\circ}\text{C}/\text{W}$
	R_{thj-A}	EMP package	-	40	-	$^{\circ}\text{C}/\text{W}$

Notes

1. All voltages are with respect to ground. Currents are positive into, negative out of specified terminal.
2. All ground pins soldered onto a 20 cm^2 PCB copper area with free air convection. $T_a = +25^{\circ}\text{C}$.
3. DIP package with external heatsink (Staver V7) and minimal copper area. Typical $R_{thj-A} = 27.5^{\circ}\text{C}/\text{W}$. $T_a = +25^{\circ}\text{C}$.
4. Not covered by final test program.

■ Applications Information

Motor selection

Some stepper motors are not designed for continuous operation at maximum current. As the circuit drives a constant current through the motor, its temperature can increase, both at low- and high-speed operation.

Some stepper motors have such high core losses that they are not suited for switched-mode operation.

Interference

As the circuit operates with switched-mode current regulation, interference-generation problems can arise in some applications. A good measure is then to decouple the circuit with a 0.1 μF ceramic capacitor, located near the package across the power line V_{MM} and ground.

Also make sure that the V_{R} input is sufficiently decoupled. An electrolytic capacitor should be used in the +5 V rail, close to the circuit.

The ground leads between R_{S} , C_{C} and circuit GND should be kept as short as possible. This applies also to the leads connecting R_{S} and R_{C} to pin 16 and pin 10 respectively.

In order to minimize electromagnetic interference, it is recommended to route M_{A} and M_{B} leads in parallel on the printed circuit board directly to the terminal connector. The motor wires should be twisted in pairs, each phase separately, when installing the motor system.

Unused inputs

Unused inputs should be connected to proper voltage levels in order to obtain the highest possible noise immunity.

Ramping

A stepper motor is a synchronous motor and does not change its speed due to load variations. This means that the torque of the motor must be large enough to match the combined inertia of the motor and load for all operation modes. At speed changes, the required torque increases by the square, and the required power by the cube of the speed change. Ramping, i.e., controlled acceleration or deceleration must then be considered to avoid motor pull-out.

V_{CC} , V_{MM}

The supply voltages, V_{CC} and V_{MM} , can be turned on or off in any order. Normal dV/dt values are assumed.

Before a driver circuit board is removed from its system, all supply voltages must be turned off to avoid destructive transients from being generated by the motor.

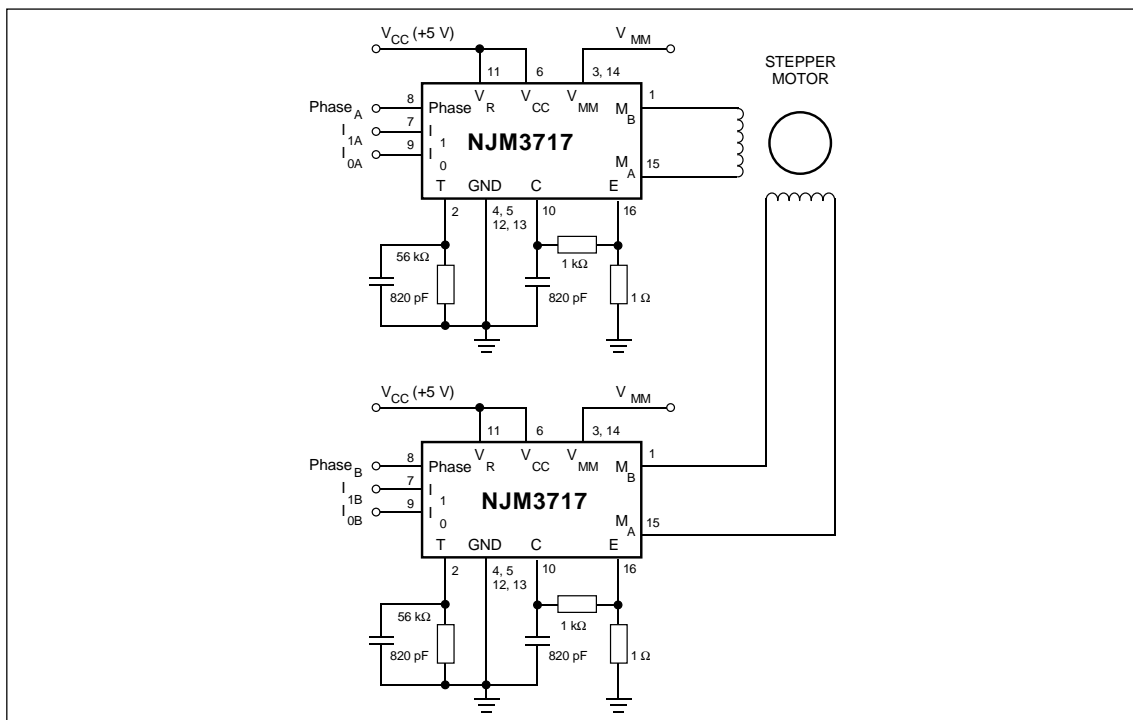

Figure 8. Typical stepper motor driver application with NJM3717

Analog control

As the current levels can be continuously controlled by modulating the V_R input, limited microstepping can be achieved.

Switching frequency

The motor inductance, together with the pulse time, t_{off} , determines the switching frequency of the current regulator. The choice of motor may then require other values on the R_T , C_T components than those recommended in figure 7, to obtain a switching frequency above the audible range. Switching frequencies above 40 kHz are not recommended because the current regulation can be affected.

Sensor resistor

The R_S resistor should be of a non-inductive type, power resistor. A 1.0 ohm resistor, tolerance $\leq 1\%$, is a good choice for 415 mA max motor current at $V_R = 5V$.

The peak motor current, i_m , can be calculated by using the formulas:

$$i_m = (V_R \cdot 0.083) / R_S \text{ [A]}, \text{ at 100\% level}$$

$$i_m = (V_R \cdot 0.050) / R_S \text{ [A]}, \text{ at 60\% level}$$

$$i_m = (V_R \cdot 0.016) / R_S \text{ [A]}, \text{ at 20\% level}$$

Heatsinking

The junction temperature of the chip highly effects the lifetime of the circuit. In high-current applications, the heatsinking must be carefully considered.

The $R_{th_{j-a}}$ of the NJM3717 can be reduced by soldering the ground pins to a suitable copper ground plane on the printed circuit board (see figure 10) or by applying an external heatsink type V7 or V8, see figure 9.

The diagram in figure 16 shows the maximum permissible power dissipation versus the ambient temperature in $^{\circ}C$, for heatsinks of the type V7, V8 or a 20 cm^2 copper area respectively. Any external heatsink or printed circuit board copper must be connected to electrical ground.

For motor currents higher than 500 mA, heatsinking is recommended to assure optimal reliability.

The diagrams in figures 9 and 10 can be used to determine the required heatsink of the circuit. In some systems, forced-air cooling may be available to reduce the temperature rise of the circuit.

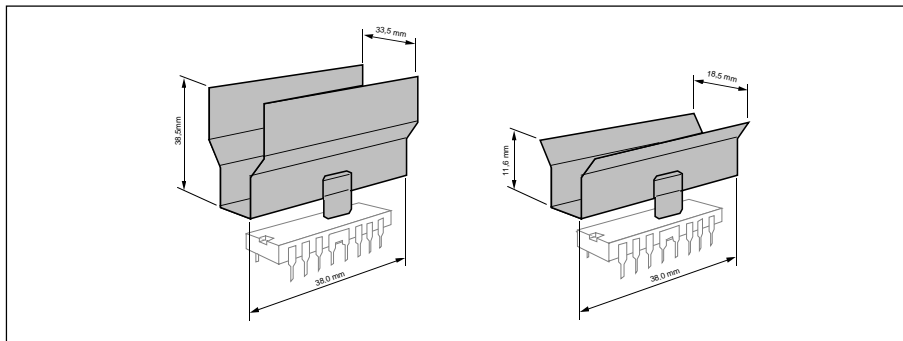

Figure 9. Heatsinks, Staver, type V7 and V8 by Columbia-Staver UK

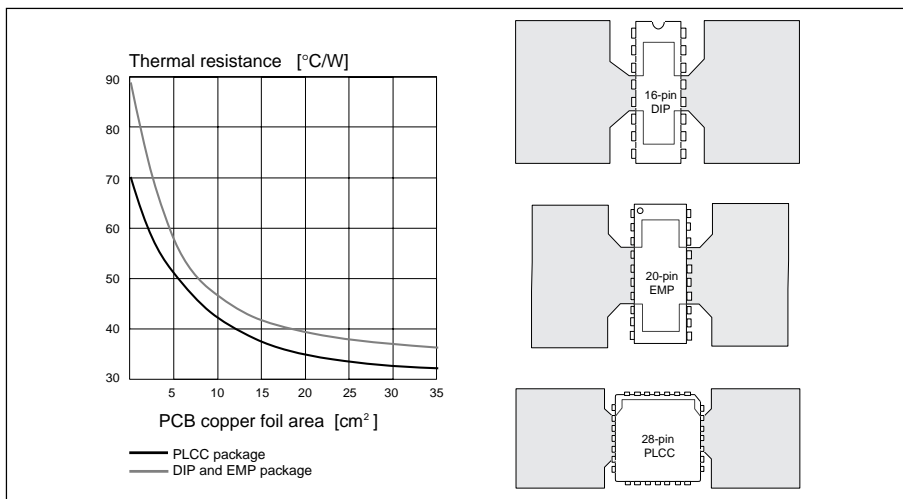

Figure 10. Copper foil used as a heatsink

■ TYPICAL CHARACTERISTICS

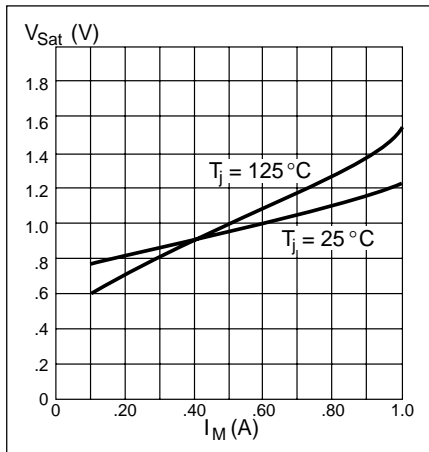

Figure 11. Typical source saturation vs. output current

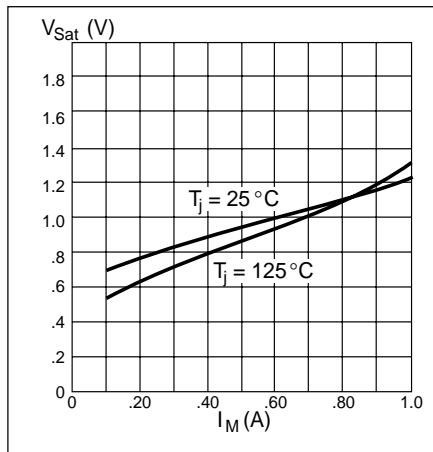

Figure 12. Typical sink saturation vs. output current

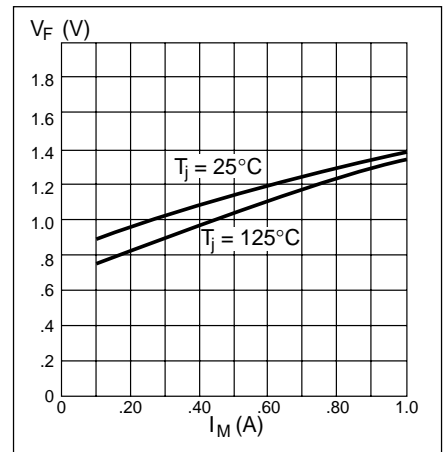

Figure 13. Typical lower diode voltage drop vs. recirculating current

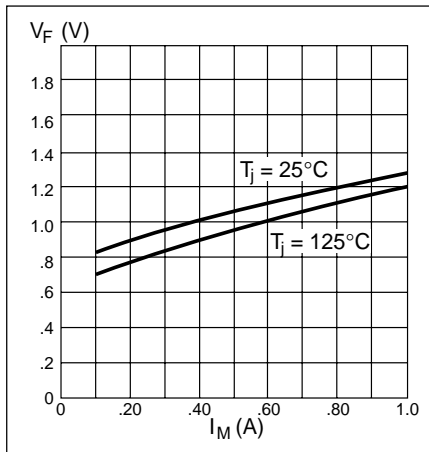

Figure 14. Typical upper diode voltage drop vs. recirculating current

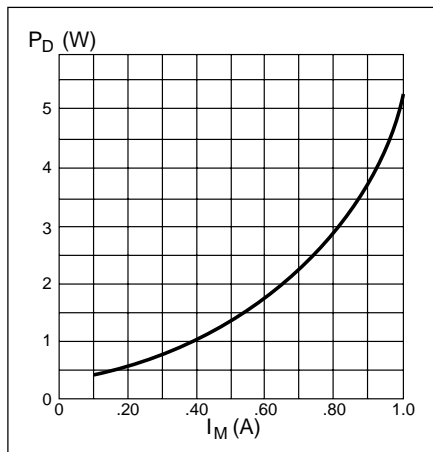

Figure 15. Typical power dissipation vs. motor current

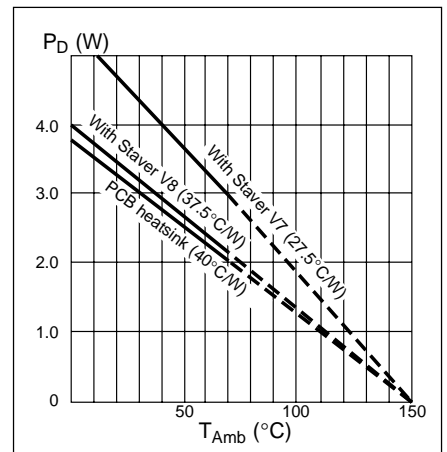

Figure 16. Allowable power dissipation vs. ambient temperature

The specifications on this databook are only given for information, without any guarantee as regards either mistakes or omissions. The application circuits in this databook are described only to show representative usages of the product and not intended for the guarantee or permission of any right including the industrial rights.

SUNSTAR 商斯达实业集团是集研发、生产、工程、销售、代理经销、技术咨询、信息服务等为一体的高科技企业，是专业高科技电子产品生产厂家，是具有 10 多年历史的专业电子元器件供应商，是中国最早和最大的仓储式连锁规模经营大型综合电子零部件代理分销商之一，是一家专业代理和分销世界各大品牌 IC 芯片和电子元器件的连锁经营综合性国际公司，专业经营进口、国产名厂名牌电子元件，型号、种类齐全。在香港、北京、深圳、上海、西安、成都等全国主要电子市场设有直属分公司和产品展示展销窗口门市部专卖店及代理分销商，已在全国范围内建成强大统一的供货和代理分销网络。我们专业代理经销、开发生产电子元器件、集成电路、传感器、微波光电元器件、工控机/DOC/DOM 电子盘、专用电路、单片机开发、MCU/DSP/ARM/FPGA 软件硬件、二极管、三极管、模块等，是您可靠的一站式现货配套供应商、方案提供商、部件功能模块开发配套商。商斯达实业公司拥有庞大的资料库，有数位毕业于著名高校——有中国电子工业摇篮之称的西安电子科技大学（西军电）并长期从事国防尖端科技研究的高级工程师为您精挑细选、量身订做各种高科技电子元器件，并解决各种技术问题。

微波光电部专业代理经销高频、微波、光纤、光电元器件、组件、部件、模块、整机；电磁兼容元器件、材料、设备；微波 CAD、EDA 软件、开发测试仿真工具；微波、光纤仪器仪表。欢迎国外高科技微波、光纤厂商将优秀产品介绍到中国、共同开拓市场。长期大量现货专业批发高频、微波、卫星、光纤、电视、CATV 器件：晶振、VCO、连接器、PIN 开关、变容二极管、开关二极管、低噪晶体管、功率电阻及电容、放大器、功率管、MMIC、混频器、耦合器、功分器、振荡器、合成器、衰减器、滤波器、隔离器、环行器、移相器、调制解调器；光电子元件和组件：红外发射管、红外接收管、光电开关、光敏管、发光二极管和发光二极管组件、半导体激光二极管和激光器组件、光电探测器和光接收组件、光发射接收模块、光纤激光器和光放大器、光调制器、光开关、DWDM 用光发射和接收器件、用户接入系统光收发器件与模块、光纤连接器、光纤跳线/尾纤、光衰减器、光纤适配器、光隔离器、光耦合器、光环行器、光复用器/转换器；无线收发芯片和模组、蓝牙芯片和模组。

更多产品请看本公司产品专用销售网站：

商斯达中国传感器科技信息网：<http://www.sensor-ic.com/>

商斯达工控安防网：<http://www.pc-ps.net/>

商斯达电子元器件网：<http://www.sunstare.com/>

商斯达微波光电产品网：[HTTP://www.rfoe.net/](http://www.rfoe.net/)

商斯达消费电子产品网：<http://www.icasic.com/>

商斯达实业科技产品网：<http://www.sunstars.cn/> 微波元器件销售热线：

地址：深圳市福田区福华路福庆街鸿图大厦 1602 室

电话：0755-82884100 83397033 83396822 83398585

传真：0755-83376182 (0) 13823648918 MSN: SUNS8888@hotmail.com

邮编：518033 E-mail:szss20@163.com QQ: 195847376

深圳赛格展销部：深圳华强北路赛格电子市场 2583 号 电话：0755-83665529 25059422

技术支持：0755-83394033 13501568376

欢迎索取免费详细资料、设计指南和光盘；产品凡多，未能尽录，欢迎来电查询。

北京分公司：北京海淀区知春路 132 号中发电子大厦 3097 号

TEL: 010-81159046 82615020 13501189838 FAX: 010-62543996

上海分公司：上海市北京东路 668 号上海赛格电子市场 D125 号

TEL: 021-28311762 56703037 13701955389 FAX: 021-56703037

西安分公司：西安高新开发区 20 所(中国电子科技集团导航技术研究所)

西安劳动南路 88 号电子商城二楼 D23 号

TEL: 029-81022619 13072977981 FAX:029-88789382