

## 12-CHARACTER 2-LINE DOT MATRIX LCD CONTROLLER DRIVER

### ■ GENERAL DESCRIPTION

The **NJU6461** is a Dot Matrix LCD controller driver for 12-character 2-line with icon display in single chip.

It contains voltage converter, bleeder resistance, CR oscillator, microprocessor interface circuits, instruction decoder controller, character generator ROM/RAM, high voltage operation common and segment drivers.

The voltage tripler and bleeder resistance generates about triple voltage (8V) and bias voltage for LCD driving waveform internally from single power supply (3V). Consequently, high-contrast display can be performed through the simple power supply circuits.

The microprocessor interface circuits which operate by 1MHz, can be selected serial, 4 or 8bit bus.

The character generator consists of 9,600 bits ROM and 32 x 5 bits RAM.

The **NJU6461** has two versions regarding the oscillation circuits, version A incorporates C and R, and version B incorporates only C.

The 18-common (16 for character, 2 for icon) and 60-segment drivers are operated up to 13.5V drives 12-character 2-line with 60 icons LCD display.

### ■ PACKAGE OUTLINE

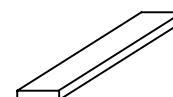

NJU6461CCL

### ■ FEATURES

- 12-character 2-line Dot Matrix LCD Controller Driver
- Maximum 60 icon Display (Using COMMK1 and COMMK2)
- Serial, 4 or 8 Bit parallel Direct Interface with Microprocessor
- Display Data RAM - 24 x 8 bits : Maximum 12-character 2-line Display
- Character Generator ROM - 9,600 bits : 240 Characters for 5 x 7 Dots
- Character Generator RAM - 32 x 5 bits : 4 Patterns (5 x 7 Dots)
- High Voltage LCD Driver : 18-common / 60-segmen
- Maximum Display Character Number (1/18 Duty):

Device	Display Character	Position of COMMK	Oscillation Circuits	Duty of COMMK
NJU6461C	12-Character 2-Line + Max.60 Icon Disp.	Upper Side or Lower Side	Internal C and R (Osc Freq.=80kHz)	1/18

\* When other Oscillation Frequency is required, please use version B and fix the Ext. R

- Useful Instruction Set : Clear Display, Return Home, Display ON/OFF Cont, Cursor ON/OFF Cont, Display Blink, Cursor Shift, Character Shift
- Power On Initialization / Hardware Reset
- Voltage converter and Bleeder Resistance On-chip
- Oscillation Circuit On-chip
- Low Power Consumption
- Operating Voltage 2.4 to 3.6 V (Except LCD Driving Voltage)
- Package Outline Bumped Chip / TCP
- C-MOS Technology

# NJU6461

## ■ PAD LOCATION

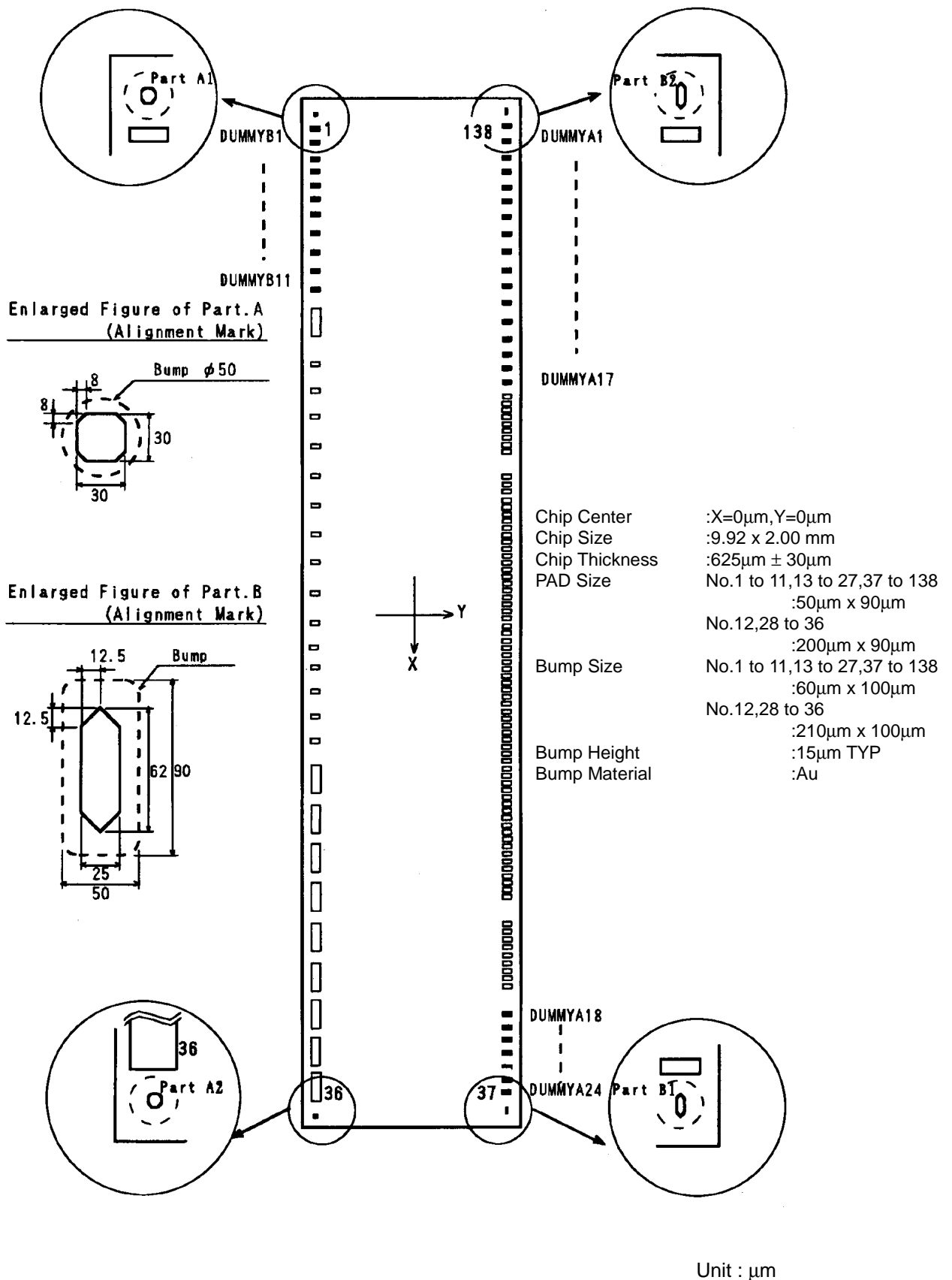

## ■ PAD COORDINATES

CHIP SIZE 9.92mm x 2.00mm  
( CHIP CENTER X=0 μm, Y=0 μm )

PAD No	PAD NAME	X= ( μm)	Y= ( μm)
1	DUMMYB <sub>1</sub>	-4645	- 830
2	DUMMYB <sub>2</sub>	-4525	- 830
3	DUMMYB <sub>3</sub>	-4405	- 830
4	DUMMYB <sub>4</sub>	-4285	- 830
5	DUMMYB <sub>5</sub>	-4165	- 830
6	DUMMYB <sub>6</sub>	-4045	- 830
7	DUMMYB <sub>7</sub>	-3925	- 830
8	DUMMYB <sub>8</sub>	-3805	- 830
9	DUMMYB <sub>9</sub>	-3685	- 830
10	DUMMYB <sub>10</sub>	-3565	- 830
11	DUMMYB <sub>11</sub>	-3445	- 830
12	V <sub>SS</sub>	-3125	- 830
13	DB <sub>7</sub> /CS	-2805	- 830
14	DB <sub>6</sub> /SIO	-2485	- 830
15	DB <sub>5</sub>	-2165	- 830
16	DB <sub>4</sub>	-1845	- 830
17	DB <sub>3</sub>	-1525	- 830
18	DB <sub>2</sub>	-1205	- 830
19	DB <sub>1</sub>	- 885	- 830
20	DB <sub>0</sub>	- 565	- 830
21	E/SCL	- 245	- 830
22	R/W	75	- 830
23	RS	395	- 830
24	P/S	715	- 830
25	RESET	1035	- 830
26	OSC <sub>2</sub>	1355	- 830
27	OSC <sub>1</sub>	1675	- 830
28	V <sub>DD</sub>	1995	- 830
29	V <sub>CI</sub>	2315	- 830
30	C1 <sup>+</sup>	2635	- 830
31	C1 <sup>-</sup>	2955	- 830
32	C2 <sup>+</sup>	3275	- 830
33	C2 <sup>-</sup>	3595	- 830
34	V <sub>5OUT</sub>	3915	- 830
35	V <sub>SS</sub>	4235	- 830
36	V <sub>5</sub>	4555	- 830
37	DUMMYA <sub>24</sub>	4620	840
38	DUMMYA <sub>23</sub>	4500	840
39	DUMMYA <sub>22</sub>	4380	840
40	DUMMYA <sub>21</sub>	4260	840
41	DUMMYA <sub>20</sub>	4140	840
42	DUMMYA <sub>19</sub>	4020	840
43	DUMMYA <sub>18</sub>	3900	840
44	COMM <sub>1</sub>	3780	840
45	COM <sub>1</sub>	3700	840
46	COM <sub>2</sub>	3620	840
47	COM <sub>3</sub>	3540	840
48	COM <sub>4</sub>	3460	840
49	COM <sub>5</sub>	3380	840
50	COM <sub>6</sub>	3300	840

PAD No	PAD NAME	X= ( μm)	Y= ( μm)
51	COM <sub>7</sub>	3220	840
52	COM <sub>8</sub>	3140	840
53	SEG <sub>1</sub>	2900	840
54	SEG <sub>2</sub>	2820	840
55	SEG <sub>3</sub>	2740	840
56	SEG <sub>4</sub>	2660	840
57	SEG <sub>5</sub>	2580	840
58	SEG <sub>6</sub>	2500	840
59	SEG <sub>7</sub>	2420	840
60	SEG <sub>8</sub>	2340	840
61	SEG <sub>9</sub>	2260	840
62	SEG <sub>10</sub>	2180	840
63	SEG <sub>11</sub>	2100	840
64	SEG <sub>12</sub>	2020	840
65	SEG <sub>13</sub>	1940	840
66	SEG <sub>14</sub>	1860	840
67	SEG <sub>15</sub>	1780	840
68	SEG <sub>16</sub>	1700	840
69	SEG <sub>17</sub>	1620	840
70	SEG <sub>18</sub>	1540	840
71	SEG <sub>19</sub>	1460	840
72	SEG <sub>20</sub>	1380	840
73	SEG <sub>21</sub>	1300	840
74	SEG <sub>22</sub>	1220	840
75	SEG <sub>23</sub>	1140	840
76	SEG <sub>24</sub>	1060	840
77	SEG <sub>25</sub>	980	840
78	SEG <sub>26</sub>	900	840
79	SEG <sub>27</sub>	820	840
80	SEG <sub>28</sub>	740	840
81	SEG <sub>29</sub>	660	840
82	SEG <sub>30</sub>	580	840
83	SEG <sub>31</sub>	500	840
84	SEG <sub>32</sub>	420	840
85	SEG <sub>33</sub>	340	840
86	SEG <sub>34</sub>	260	840
87	SEG <sub>35</sub>	180	840
88	SEG <sub>36</sub>	100	840
89	SEG <sub>37</sub>	20	840
90	SEG <sub>38</sub>	- 60	840
91	SEG <sub>39</sub>	- 140	840
92	SEG <sub>40</sub>	- 220	840
93	SEG <sub>41</sub>	- 300	840
94	SEG <sub>42</sub>	- 380	840
95	SEG <sub>43</sub>	- 460	840
96	SEG <sub>44</sub>	- 540	840
97	SEG <sub>45</sub>	- 620	840
98	SEG <sub>46</sub>	- 700	840
99	SEG <sub>47</sub>	- 780	840
100	SEG <sub>48</sub>	- 860	840

3

**3**

PAD No	PAD NAME	X= (μm)	Y= (μm)
101	SEG <sub>49</sub>	- 940	840
102	SEG <sub>50</sub>	-1020	840
103	SEG <sub>51</sub>	-1100	840
104	SEG <sub>52</sub>	-1180	840
105	SEG <sub>53</sub>	-1260	840
106	SEG <sub>54</sub>	-1340	840
107	SEG <sub>55</sub>	-1420	840
108	SEG <sub>56</sub>	-1500	840
109	SEG <sub>57</sub>	-1580	840
110	SEG <sub>58</sub>	-1660	840
111	SEG <sub>59</sub>	-1740	840
112	SEG <sub>60</sub>	-1820	840
113	COMMK <sub>2</sub>	-1980	840
114	COM <sub>16</sub>	-2060	840
115	COM <sub>15</sub>	-2140	840
116	COM <sub>14</sub>	-2220	840
117	COM <sub>13</sub>	-2300	840
118	COM <sub>12</sub>	-2380	840
119	COM <sub>11</sub>	-2460	840
120	COM <sub>10</sub>	-2540	840
121	COM <sub>9</sub>	-2620	840
122	DUMMYA <sub>17</sub>	-2740	840
123	DUMMYA <sub>16</sub>	-2860	840
124	DUMMYA <sub>15</sub>	-2980	840
125	DUMMYA <sub>14</sub>	-3100	840
126	DUMMYA <sub>13</sub>	-3220	840
127	DUMMYA <sub>12</sub>	-3340	840
128	DUMMYA <sub>11</sub>	-3460	840
129	DUMMYA <sub>10</sub>	-3580	840
130	DUMMYA <sub>9</sub>	-3700	840
131	DUMMYA <sub>8</sub>	-3820	840
132	DUMMYA <sub>7</sub>	-3940	840
133	DUMMYA <sub>6</sub>	-4060	840
134	DUMMYA <sub>5</sub>	-4180	840
135	DUMMYA <sub>4</sub>	-4300	840
136	DUMMYA <sub>3</sub>	-4420	840
137	DUMMYA <sub>2</sub>	-4540	840
138	DUMMYA <sub>1</sub>	-4660	840
Alignment	A1	-4770	-830
Alignment	A2	4755	-830
Alignment	B1	4745	840
Alignment	B2	-4785	840

■ BLOCK DIAGRAM

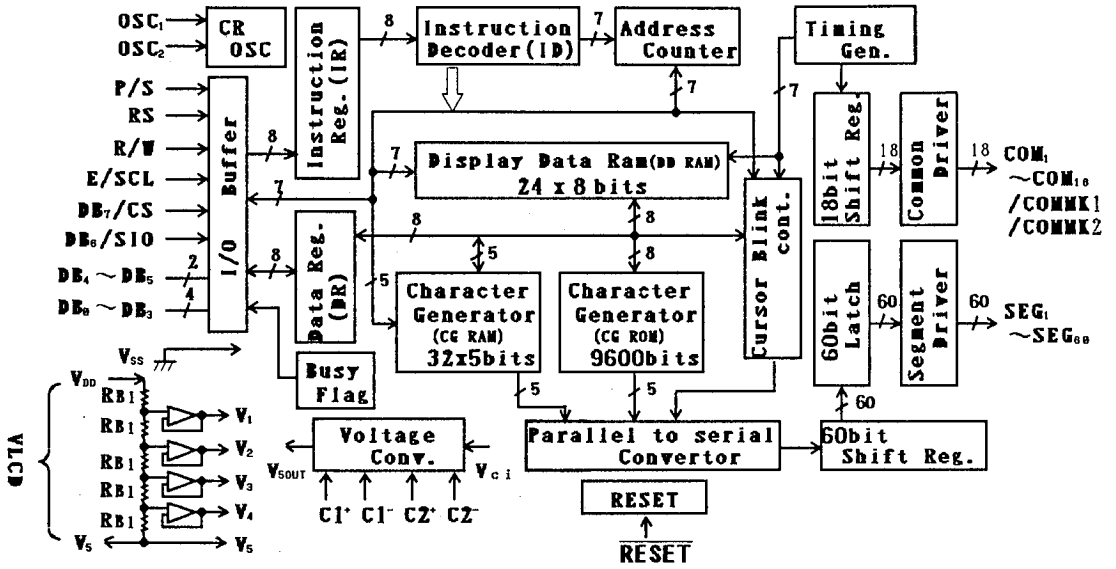

## ■ TERMINAL DESCRIPTION

PAD NO.	SYMBOL	I/O	F U N C T I O N
28	V <sub>DD</sub>		Power Source ( + 3V )
12	V <sub>SS</sub>		Power Source ( 0V )
36	V <sub>5</sub>		LCD Driving Voltage Output An alignment pattern is placed beside this terminal.
27 26	OSC <sub>1</sub> OSC <sub>2</sub>	I	Version A -Oscillation Frequency Adjust Terminals. Normally Open For external clock operation, the clock should be input on OSC <sub>1</sub> . Version B -Connect the External Resistance.
24	P/S	I	Parallel or serial Interface select input Terminal. "0" : Serial Interface, "1" : Parallel Interface
23	RS	I	Register selection signal input Terminal. (Pull-up) "0" : Instruction Register (Writing) Busy Flag, Address Counter (Reading) "1" : Data Register (Writing/Reading)
22	R/W	I	Read/Write selection signal input Terminal.(Pull-up) "0" : Write, "1" : Read
21	E	I	Read/Write activation signal input in Parallel input mode.
	SCL	I	Shift Clock Input in Serial input mode.
13	DB <sub>7</sub>	I/O	3-state Data Bus for Upper bit to transfer the data between MPU and NJU6461 in Parallel operation mode. DB <sub>7</sub> is also used for the Busy Flag reading in Parallel op. mode.
	CS	I	Chip select signal input in Serial operation mode.
14	DB <sub>6</sub>	I/O	3-state Data Bus for Upper bit to transfer the data between MPU and NJU6461 in Parallel operation mode.
	SIO	I/O	Serial data I/O in Serial operation mode.
15 16	DB <sub>5</sub> DB <sub>4</sub>	I/O	3-state Data Bus for Upper bit to transfer the data between MPU and NJU6461 in Parallel operation mode. When the Serial operation mode, these terminal should be open.
17~20	DB <sub>3</sub> ~DB <sub>0</sub>	I/O	3-state Data Bus for Lower bit to transfer the data between MPU and NJU6461 in Parallel operation mode. These bus are not used in the Serial and 4-bit operation (open).
45~52 121~114	COM <sub>1</sub> ~COM <sub>8</sub> COM <sub>9</sub> ~COM <sub>16</sub>	0	LCD Common Driving Signal output terminals.
44 113	COMMK1 COMMK2	0	Icon Common Driving Signal output terminals.
53~112	SEG <sub>1</sub> ~SEG <sub>60</sub>	0	LCD Segment Driving Signal output terminals.
30,31	C <sub>1</sub> <sup>+</sup> , C <sub>1</sub> <sup>-</sup>	I/O	Step up Capacitor Connecting Terminals. Connect the step up capacitor between C <sub>1</sub> <sup>+</sup> and C <sub>1</sub> <sup>-</sup> , C <sub>2</sub> <sup>+</sup> and C <sub>2</sub> <sup>-</sup> respectively.
32,33	C <sub>2</sub> <sup>+</sup> , C <sub>2</sub> <sup>-</sup>		
29	V <sub>ci</sub>	I	Input Terminal for Voltage converter. (Normally V <sub>ci</sub> = V <sub>DD</sub> )
34	V <sub>5OUT</sub>	0	Step up voltage Output Terminal.
25	RESET	I	Reset Terminal. When the "L" level input over then 1.2ms to this terminal, the system will be reset(f <sub>osc</sub> =80kHz)
2~11 137~122 43~38	DUMMYB <sub>2</sub> ~ DUMMYB <sub>11</sub> DUMMYA <sub>2</sub> ~ DUMMYA <sub>23</sub>		DUMMY Terminals. These terminals are electrically open.
1 138 37	DUMMYB <sub>1</sub> DUMMYA <sub>1</sub> DUMMYA <sub>24</sub>		DUMMY Terminals. These terminals are electrically open and an alignment pattern is placed beside each terminal.

## ■ FUNCTIONAL DESCRIPTION

### (1) Description for each blocks

#### (1-1) Register

The NJU6461 incorporates two 8-bit registers, an Instruction Register (IR) and a Data Register (DR). The Register(IR) stores instruction codes such as "Clear Display" and "Cursor Shift", and address data for Display Data RAM (DD RAM) and Character Generator RAM (CG RAM).

The MPU can write the instruction code and address data to the Register(IR), but it cannot read out from the Register(IR).

The Register(DR) is a temporary stored register, the data stored in the Register(DR) is written into the DD RAM or CG RAM and read out from the DD RAM or CG RAM.

The data in the Register(DR) written by the MPU is transferred automatically to the DD RAM or CG RAM by internal operation.

When the address data for the DD RAM or CG RAM is written into the Register(IR), the addressed data in the DD RAM or CG RAM is transferred to the Register(DR). By the MPU read out the data in the Register(DR), the data transmitting process is performed completely.

After reading the data in the Register(DR) by the MPU, the next address data in the DD RAM or CG RAM is transferred automatically to the Register(DR) to provide for the next MPU reading.

These two registers are selected by the selection signal RS as shown below.

Table 1. shows register operation controlled by RS and R/W signals.

Table 1. Register Operation

RS	R/W	Selected Register	Operation
0	0	IR	Write
0	1		Read busy flag (DB <sub>7</sub> ) and address counter (DB <sub>6</sub> ~DB <sub>0</sub> )
1	0	DR	Write (Register(DR) to DD RAM or CG RAM)
1	1		Read (DD RAM or CG RAM to Register(DR))

#### (1-2) Busy Flag (BF)

When the internal circuits are in the operation mode, the busy flag (BF) is "1", and any instruction reading is inhibited.

The busy flag (BF) is output at DB<sub>7</sub> when RS="0" and R/W="1" as shown in Table 1.

The next instruction should be written after the busy flag (BF) goes to "0".

#### (1-3) Address Counter (AC)

The address counter (AC) addressing the DD RAM and CG RAM.

When the address setting instruction is written into the Register(IR), the address information is transferred from Register(IR) to the Counter (AC). The selection of either the DD RAM or CG RAM is also determined by this instruction.

After writing (or reading) the display data to (or from) the DD RAM or CG RAM, the Counter (AC) increments (or decrements) automatically.

The address data in the Counter (AC) is output from DB<sub>6</sub>~DB<sub>0</sub> when RS="0" and R/W="1" as shown in Table 1.

### (1-4) Display Data RAM (DD RAM)

The display data RAM (DD RAM) consists of 24 x 8 bits stores up to 24-character display data represented in 8-bit code.

The DD RAM address data set in the address counter(AC) is represented in Hexadecimal.

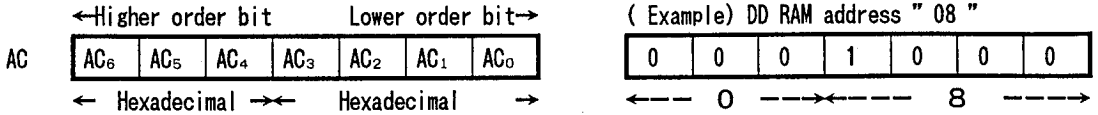

The relation between DD RAM address and display position on the LCD is shown below.

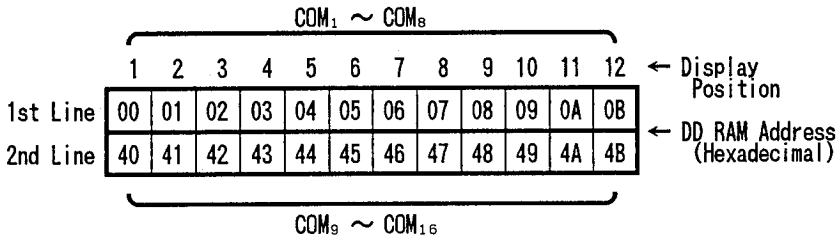

Note : In the 2 lines display mode, the 1st and 2nd line address are defined as (00)<sub>H</sub> to (0B)<sub>H</sub> and (40)<sub>H</sub> to (4B)<sub>H</sub>. Please note that the end of 1st line address and the beginning of 2nd line address are not consecutive.

When the display shift is performed, the DD RAM address changes as follows:

( Left Shift Display )

	1	2	3	4	5	6	7	8	9	10	11	12	
(00)←	01	02	03	04	05	06	07	08	09	0A	0B	00	
(40)←	41	42	43	44	45	46	47	48	49	4A	4B	40	

( Right Shift Display )

	1	2	3	4	5	6	7	8	9	10	11	12	
	0B	00	01	02	03	04	05	06	07	08	09	0A	→(0B)
	4B	40	41	42	43	44	45	46	47	48	49	4A	→(4B)

### (1-5) Character Generator ROM (CG ROM)

The Character Generator ROM (CG ROM) generates 5 x 7 dots character pattern represented in 8-bit character codes.

The storage capacity is up to 240 kinds of 5 x 7 dots character pattern.

The correspondence between character code and standard character pattern of NJU6461 is shown in Table 2-1.

User-defined character patterns (Custom Font) are also available by mask option.



Table 2-1. CG ROM Character Pattern ( ROM version -02 )

		Upper 4-bit ( Hexadecimal )															
		0	1	2	3	4	5	6	7	8	9	A	B	C	D	E	F
Lower 4-bit ( Hexadecimal )	0	CG RAM (01)	À		0	a	P	`	F	Q	É		—	9	3	0	P
	1	(02)	È	!	1	A	Q	a	9	U	æ	»	7	7	4	ä	9
	2	(03)	à	"	2	B	R	b	r	é	È	†	ı	ı	ı	æ	æ
	3	(04)	ı	#	3	C	S	c	s	à	ö	.	ı	ı	ı	æ	æ
	4	(01)	ö	*	4	D	T	d	t	ä	ö	.	ı	ı	ı	ı	ı
	5	(02)	ö	%	5	E	U	e	u	à	ö	.	ı	ı	ı	ı	ı
	6	(03)	À	&	6	F	V	f	v	ä	ö	ı	ı	ı	ı	ı	ı
	7	(04)	À	'	7	G	W	g	w	9	ı	ı	ı	ı	ı	ı	ı
	8	(01)	æ	(	8	H	X	h	x	é	9	.	ı	ı	ı	ı	ı
	9	(02)	9	)	9	I	Y	i	y	é	ö	ı	ı	ı	ı	ı	ı
	A	(03)	ı	*	#	J	Z	j	z	é	ö	ı	ı	ı	ı	ı	ı
	B	(04)	ı	+	:	K	I	k	<	i	é	ı	ı	ı	ı	ı	ı
	C	(01)	ı	.	<	L	*	ı	ı	ı	é	ı	ı	ı	ı	ı	ı
	D	(02)	ı	—	=	M	I	m	>	ı	ı	ı	ı	ı	ı	ı	ı
	E	(03)	ı	.	>	N	^	n	ı	ı	ı	ı	ı	ı	ı	ı	ı
	F	(04)	ı	/	?	O	_	o	ı	ı	ı	ı	ı	ı	ı	ı	ı

## (1-6) Character Generator RAM (CG RAM)

The character generator RAM (CG RAM) can store any kind of character pattern in 5 x 7 dots written by the user program to display user's original character pattern and icon data. The CG RAM can store 4 kind of character in 5 x 7 dots mode or 2 kind of character in 5 x 7 dots mode and icon data.

To display user's original character pattern stored in the CG RAM, the address data (00)<sub>H</sub> - (03)<sub>H</sub> should be written to the DD RAM as shown in Table 2-1.

Table 3. show the correspondence among the character pattern, CG RAM address and Data.

Table 3. Correspondence of CG RAM address, DD RAM character code and CG RAM character pattern( 5 x 7 dots ).

Character Code (DD RAM Data)	CG RAM Address	Character Pattern (CG RAM Data)
7 6 5 4 3 2 1 0 ←-----→ Upper bit Lower bit	4 3 2 1 0 ←-----→ Upper bit Lower bit	4 3 2 1 0 ←-----→ Upper bit Lower bit
0 0 0 0 * * 0 0	0 0	0 0 0 0 0 0 0 1 0 1 0 0 0 1 1 0 1 0 0 0 1 0 1 0 1 1 0 0 1 1 1 0 0 0 0 0 0 0
0 0 0 0 * * 0 1	0 1	0 0 0 0 0 0 0 1 0 1 0 0 0 1 1 0 1 0 0 0 1 0 1 0 1 1 0 0 1 1 1 0 0 0 0 0 0 0
0 0 0 0 * * 1 1	1 1	1 0 0 0 1 0 1 0 1 1 0 0 1 1 1 0

\* : Don't Care

- Notes :
- Character code bit 0, 1 correspond to the CG RAM address 3, 4(2bits:4 patterns).
  - CG RAM address 0 to 2 designate character pattern line position. The 8th line is the cursor position and the display is performed by logical OR with cursor. Therefore, in case of the cursor display, the 8th line should be "0". If there is "1" in the 8th line, the bit "1" is always displayed on the cursor position regardless of cursor existence.
  - Character pattern row position correspond to the CG RAM data bits 0 to 4 are shown above.
  - CG RAM character patterns are selected when character code bits 4 to 7 are all "0" and it is addressed by character code bits 0 and 1. Therefore, the address (00)<sub>H</sub>, (04)<sub>H</sub>, (08)<sub>H</sub> and (0C)<sub>H</sub> select the same character pattern as shown in Table 2-1.
  - "1" for CG RAM data corresponds to display On and "0" to display Off.
  - CG RAM address (14)<sub>H</sub> to (1F)<sub>H</sub> are using for both of character pattern memory and icon data memory.

## (1-7) Icon Display Function

The NJU6461 can display not only 5 x 7 bits character pattern but also maximum 60 icons.

The icon can display by writing bit "1" to each data bit 0 to 4 in the address  $(14)_H \sim (1F)_H$  of CG RAM.

The fixed character display code is not affected except CG RAM writing and display ON/OFF instruction.

The relation between CG RAM address and icon display position on the LCD is fixed even if the display shift is executed. The relation is shown below:

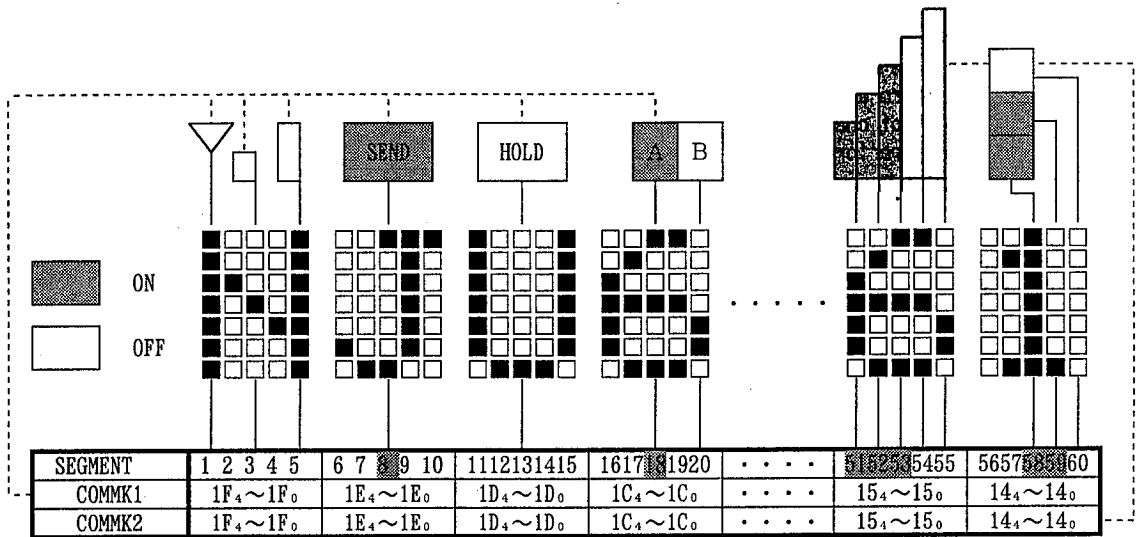

NOTE) The  $1F_4$  corresponds bit 4 of  $(1F)_H$  in CG RAM.

< CG RAM vs. SEG terminal  
for icon display >

CG RAM address	data	SEG terminal
	43210	
14	00110	56~60
15	11100	51~55
16	.....	46~50
17	.....	41~45
18	.....	36~40
19	.....	31~35
1A	.....	26~30
1B	.....	21~25
1C	00100	16~20
1D	00000	11~15
1E	00100	6~10
1F	00000	1~5

## Maximum Character Number and Icon Display Number in CG RAM

Icon Disp. Number	Max. Chara Number	Note
No Use	4 Chara.	The CG RAM can store 4 kind of Character
40 Icons	3 Chara.	$(03)_H, (07)_H, (0B)_H$ and $(0F)_H$ can not use for Character Memory.
60 Icons	2 Chara.	$(02)_H, (03)_H, (06)_H, (07)_H, (0A)_H, (0B)_H, (0E)_H$ and $(0F)_H$ can not use for Character Memory.

NOTE) When the icon display function using, the system should be initialized by the software initialization because of the CG RAM does not initialize except the software initialization.

**(1-8) Timing Generator**

The timing generator generates a timing signals for the DD RAM, CG RAM, CG ROM and other internal circuits.

RAM read timing for the display and internal operation timing for MPU access are separately generated, so that they may not interfere with each other.

Therefore, when the data write to the DD RAM for example, there will be no undesirable influence, such as flickering, in areas other than the display area.

**(1-9) LCD Driver**

LCD driver consist of 18-common driver and 60-segment driver.

When the line number is selected by a program, the required common drivers output the common driving waveform and the other common drivers output non-selection waveform automatically.

The 60 bits of character pattern data are shifted in the shift-register and latched when the 60 bits shift performed completely. This latched data controls display driver to output LCD driving waveform.

**(1-10) Cursor Blinking Control Circuit**

This circuits controls cursor On/Off and the cursor position character blinks.

The cursor or blinks appear in the digit residing at the DD RAM address set in the address counter (AC).

When the address counter is (08)<sub>H</sub>, a cursor position is shown as follows:

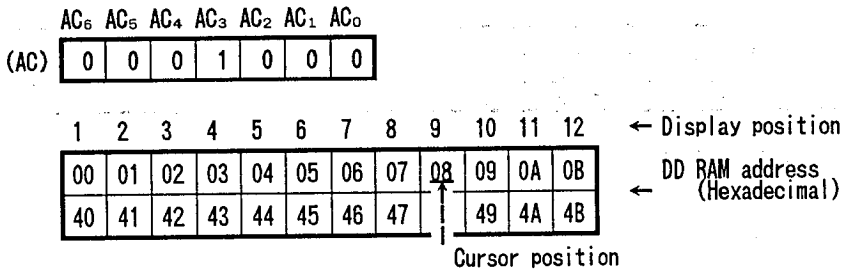

(Note) The cursor or blinks also appear when the address counter (AC) selects the CG RAM. But the displayed cursor and blink are meaningless.

If the AC storing the CG RAM address data, the cursor and blink are displayed in the meaningless position.

## (2) Power on Initialization by internal circuits

### (2-1) Initialization By Internal Reset Circuits

The NJU6461 is automatically initialized by internal power on initialization circuits when the power is turned on. In the internal power on initialization, following instructions are executed. During the Internal power on initialization, the busy flag (BF) is "1" and this status is kept 10 ms after  $V_{DD}$  rises to 2.4V.

Initialization flow is shown below:

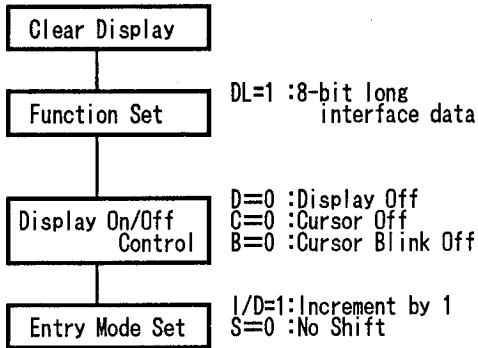

#### NOTE

If the condition of power supply rise time described in the Electrical Characteristics is not satisfied, the internal Power On Initialization Circuits will not operated and initialization will not performed. In this case the initialization by MPU software is required.

**(2-2) Initialization By Hardware**

The NJU6461 incorporates  $\overline{\text{RESET}}$  terminal to initialize the all system. When the "L" level input over than 1.2ms to the  $\overline{\text{RESET}}$  terminal, reset sequence is executed. In this time, busy signal output during 10ms after  $\overline{\text{RESET}}$  terminal goes to "H".

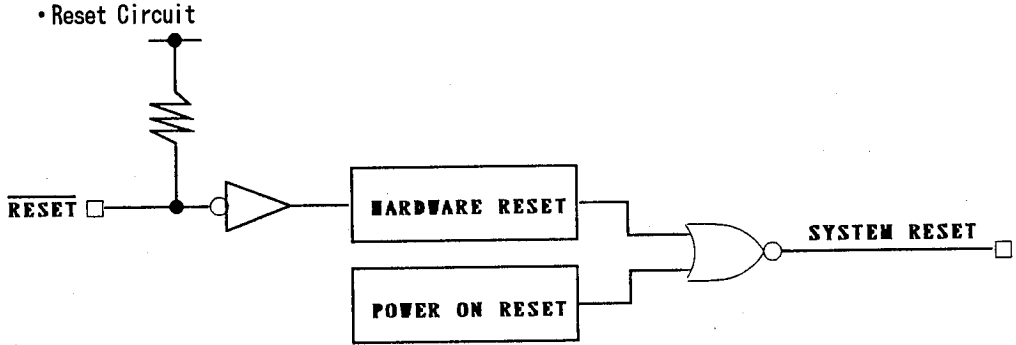

• Timing Chart

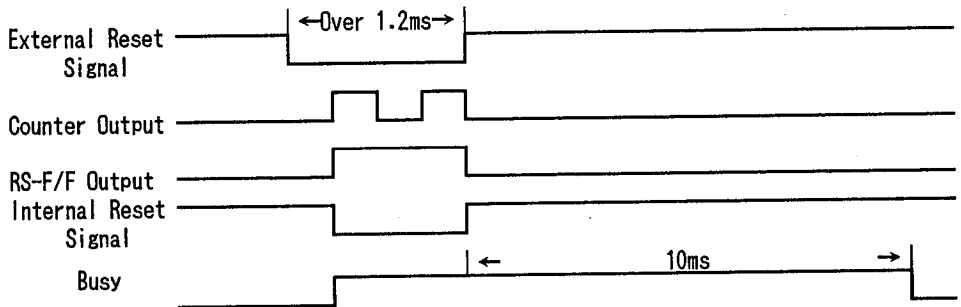

**(3) Instructions**

The NJU6461 incorporates two registers, an Instruction Register (IR) and a Data Register (DR). These two registers store control information temporarily to allow interface between NJU6461 and MPU or peripheral ICs operating different cycles. The operation of NJU6461 is determined by this control signal from MPU. The control information includes register selection signals (RS), read/write signals (R/W) and data bus signals ( $\text{DB}_0$  to  $\text{DB}_7$ ).

Table 4. shows each instruction and its operating time.

Note 1) The execution time mentioned in Table 4. based on  $f_{cp}$  or  $f_{osc}=80\text{kHz}$ .  
If the oscillation frequency is changed, the execution time is also changed.

Table 4. Table of Instructions

INSTRUCTIONS	RS	R/W	C DB <sub>7</sub>	O DB <sub>6</sub>	D DB <sub>5</sub>	E DB <sub>4</sub>	DB <sub>3</sub>	DB <sub>2</sub>	DB <sub>1</sub>	DB <sub>0</sub>	DESCRIPTION	EXEC TIME
Maker Testing	0	0	0	0	0	0	0	0	0	0	All "0" code is using for maker testing.	
Clear Display	0	0	0	0	0	0	0	0	0	1	Display clear and sets DD RAM address 0 in AC.	1.63ms
Return Home	0	0	0	0	0	0	0	0	1	*	Sets DD RAM address 0 in AC and returns display being shifted to original position. DD RAM contents remain unchanged	125us
Entry Mode Set	0	0	0	0	0	0	0	1	I/D	S	Sets cursor move direction and specifies shift of display are performed in data read/write. I/D=1:Increment, I/D=0:Decrement S=1:Accompanies display shift	125us
Display On/Off Control	0	0	0	0	0	0	1	D	C	B	Sets of display On/Off(D), cursor On/Off(C) and blink of cursor position character(B).	125us
Cursor or Display Shift	0	0	0	0	0	1	S/C	R/L	*	*	Moves cursor and shifts display without changing DD RAM contents S/C=1 : Display shift S/C=0 : Cursor shift R/L=1 : Shift to the right R/L=0 : Shift to the left	175us
Function Set	0	0	0	0	1	DL	1	*	*	*	Sets interface data length(DL). DL=1 : 8 bits , DL=0 : 4 bits Note: DB3 must be input "1".	125us
Set CG RAM Address	0	0	0	1	*	←	AC <sub>CG</sub>	→			Sets CG RAM address. After this instruction, the data is transferred to/from CG RAM.	125us
Set DD RAM Address	0	0	1	←	←	←	AC <sub>DD</sub>	→	→	→	Sets DD RAM address. After this instruction, the data is transferred to/from DD RAM.	125us
Read Busy Flag & Address	0	1	BF	←	←	←	AC <sub>DD</sub>	→	→	→	Reads busy flag and AC contents. BF=1 : Internally operating BF=0 : Can accept instruction	0us
	0	1	BF	*	*	←	AC <sub>CG</sub>	→	→	→		
Write Data to CG & DD RAM	1	0	←	←	←	←	Write Data (DD RAM)	→	→	→	Writes data into DD or CG RAMs.	125us
	1	0	*	*	*	←	Write Data (CG RAM)	→	→	→		
Read Data from CG or DD RAM	1	1	←	←	←	←	Read Data (DD RAM)	→	→	→	Reads data from DD or CG RAMs.	175us
	1	1	*	*	*	←	Read Data (CG RAM)	→	→	→		
Explanation of Abbreviation	DD RAM : Display data RAM , CG RAM : Character generator RAM AC <sub>CG</sub> : CG RAM address , AC <sub>DD</sub> : DD RAM address, Corresponds to cursor address AC : Address counter used for both of DD and CG RAMs											

\* Don't care

### (3-1) Description of each instructions

#### (a) Maker Testing

	RS	R/W	DB <sub>7</sub>	DB <sub>6</sub>	DB <sub>5</sub>	DB <sub>4</sub>	DB <sub>3</sub>	DB <sub>2</sub>	DB <sub>1</sub>	DB <sub>0</sub>
Code	0	0	0	0	0	0	0	0	0	0

All "0" code in 4-bit length is using for device testing mode ( only for maker ). Therefore, please avoid all "0" input or no meaning Enable signal input at data "0". (Especially please pay attention the output condition of Enable signal when the power turns on.)

#### (b) Clear Display

	RS	R/W	DB <sub>7</sub>	DB <sub>6</sub>	DB <sub>5</sub>	DB <sub>4</sub>	DB <sub>3</sub>	DB <sub>2</sub>	DB <sub>1</sub>	DB <sub>0</sub>
Code	0	0	0	0	0	0	0	0	0	1

Clear display instruction is executed when the code "1" is written into DB<sub>0</sub>. When this instruction is executed, the space code (20)<sub>H</sub> is written into every DD RAM address, the DD RAM address (00)<sub>H</sub> is set into the address counter and entry mode is set increment. If the cursor or blink are displayed, they are returned to the left end of the 1st-line in the LCD.

The S of entry mode does not change.

Note: The character pattern for character code (20)<sub>H</sub> must be blank code in the user-defined character pattern(Custom font).

#### (c) Return Home

	RS	R/W	DB <sub>7</sub>	DB <sub>6</sub>	DB <sub>5</sub>	DB <sub>4</sub>	DB <sub>3</sub>	DB <sub>2</sub>	DB <sub>1</sub>	DB <sub>0</sub>	
Code	0	0	0	0	0	0	0	0	1	*	* = Don't care

Return home instruction is executed when the code "1" is written into DB<sub>1</sub>. When this instruction is executed, the DD RAM address 0 is set into the address counter. Display is returned its original position if shifted, the cursor or blink are returned to the left end of the LCD, (the left end of the 1st line in the 2-line display mode) if the cursor or blink are on the display.

The DD RAM contents do not change.



## (d) Entry Mode Set

	RS	R/W	DB <sub>7</sub>	DB <sub>6</sub>	DB <sub>5</sub>	DB <sub>4</sub>	DB <sub>3</sub>	DB <sub>2</sub>	DB <sub>1</sub>	DB <sub>0</sub>
Code	0	0	0	0	0	0	0	1	I/D	S

Entry mode set instruction which sets the cursor moving direction and display shift On/Off, is executed when the code "1" is written into DB<sub>2</sub> and the codes of (I/D) and (S) are written into DB<sub>1</sub>(I/D) and DB<sub>0</sub>(S), as shown below.

(I/D) sets the address increment or decrement, and the (S) sets the entire display shift in the DD RAM writing.

I/D	F u n c t i o n
1	Address increment: The address of the DD RAM or CG RAM increment (+1) when the read/write, and the cursor or blink move to the right.
0	Address decrement: The address of the DD RAM or CG RAM decrement (-1) when the read/write, and the cursor or blink move to the left.

S	F u n c t i o n
1	Entire display shift. The shift direction is determined by I/D.: shift to the left at I/D=1 and shift to the right at the I/D=0. The shift is operated only for the character, so that it looks as if the cursor stands still and the display moves. The display does not shift when reading from the DD RAM and writing/reading into/from CG RAM.
0	The display does not shifting.

## (e) Display On/Off Control

	RS	R/W	DB <sub>7</sub>	DB <sub>6</sub>	DB <sub>5</sub>	DB <sub>4</sub>	DB <sub>3</sub>	DB <sub>2</sub>	DB <sub>1</sub>	DB <sub>0</sub>
Code	0	0	0	0	0	0	1	D	C	B

Display On/Off control instruction which controls the whole display On/Off, the cursor On/Off and the cursor position character blink, is executed when the code "1" is written into DB<sub>3</sub> and the codes of (D), (C) and (B) are written into DB<sub>2</sub>(D), DB<sub>1</sub>(C) and DB<sub>0</sub>(B), as shown below.

D	F u n c t i o n
1	Display On.
0	Display Off. In this mode, the display data remains in the DD RAM so that it is retrieved immediately on the display when the D change to 1.
C	F u n c t i o n
1	Cursor On. The cursor is displayed by 5 dots on the 8th line.
0	Cursor Off. Even if the display data write, the I/D etc does not change.
B	F u n c t i o n
1	The cursor position character is blinking. Blinking rate is 540ms at $f_{osc}=80kHz$ for 12-character 2-line. The cursor and the blink can be displayed simultaneously.
0	The character does not blink.

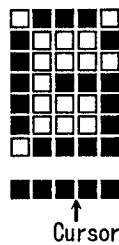

Character Font 5 x 7 dots

(1) Cursor display example

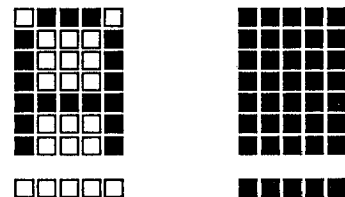

Alternating display

(2) Blink display example

## (f) Cursor/Display Shift

	RS	R/W	DB <sub>7</sub>	DB <sub>6</sub>	DB <sub>5</sub>	DB <sub>4</sub>	DB <sub>3</sub>	DB <sub>2</sub>	DB <sub>1</sub>	DB <sub>0</sub>	
Code	0	0	0	0	0	1	S/C	R/L	*	*	* = Don't care

The Cursor/Display shift instruction shifts the cursor position or display to the right or left without writing or reading display data. This function is used to correct or search the display. In the 2-line display, the cursor moves to the 2nd line when it passes the 12th digit of the 1st line. Notice that the 1st and 2nd line displays will shift at the same time. When the displayed data are shifted repeatedly, each line moves only horizontally.

The 2nd line display does not shift into the 1st line.

The contents of address counter(AC) does not change by operation of the display shift only. This instruction is executed when the code "1" is written into DB<sub>4</sub> and the codes of (S/C) and (R/L) are written into DB<sub>3</sub>(S/C) and DB<sub>2</sub>(R/L) as shown below.

S/C	R/L	F u n c t i o n
0	0	Shifts the cursor position to the left ((AC) is decremented by 1)
0	1	Shifts the cursor position to the right ((AC) is incremented by 1)
1	0	Shifts the entire display to the left and the cursor follows it.
1	1	Shifts the entire display to the right and the cursor follows it.

## (g) Function Set

	RS	R/W	DB <sub>7</sub>	DB <sub>6</sub>	DB <sub>5</sub>	DB <sub>4</sub>	DB <sub>3</sub>	DB <sub>2</sub>	DB <sub>1</sub>	DB <sub>0</sub>	
Code	0	0	0	0	1	DL	1	*	*	*	* = Don't care

Function set instruction which sets the interface data length is executed, when the code "1" is written into DB<sub>3</sub>, DB<sub>5</sub> and the code of (DL) is written into DB<sub>4</sub>(DL), as shown below. Note that the DB<sub>3</sub> is must be "1" always.

In the serial interface operation mode, the DL is no meaning.

Note  
This function set instruction must be performed at the head of the program prior to all other existing instructions(except Busy flag/Address read). This function set instruction can not be executed afterwards unless the interface data length change.

DL	F u n c t i o n
1	Set the interface data length of 8-bit (using from DB <sub>7</sub> to DB <sub>0</sub> ) in the parallel operation mode only.
0	Set the interface data length of 4-bit (using from DB <sub>7</sub> to DB <sub>4</sub> ) in the parallel operation mode only. The data must be sent or received twice in this mode.

## (h) Set CG RAM Address

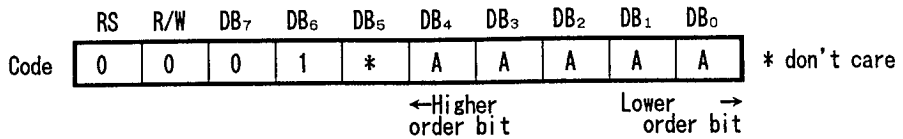

Set CG RAM address set instruction is executed when the code "1" is written into DB<sub>6</sub> and the address is written into DB<sub>4</sub> to DB<sub>0</sub> as shown above.

The address data mentioned by binary code "AAAAA" is written into the address counter (AC) together with the CG RAM addressing condition. After this instruction execution, the data writing/reading is performed into/from the CG RAM.

## (i) Set DD RAM Address

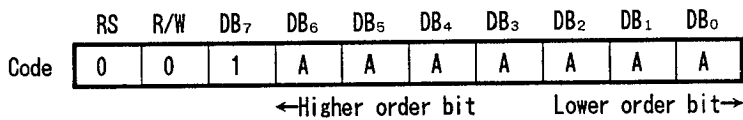

Set DD RAM address instruction is executed when the code "1" is written into DB<sub>7</sub> and the address is written into DB<sub>6</sub> to DB<sub>0</sub> as shown above.

The address data mentioned by binary code "AAAAAAA" is written into the address counter (AC) together with the DD RAM addressing condition. After this instruction execution, the data writing/reading is performed into/from the DD RAM.

Note : The [AAAAAAA] is (00)<sub>H</sub> to (0B)<sub>H</sub> for the 1st line and (40)<sub>H</sub> to (4B)<sub>H</sub> for the 2nd line.

## (j) Read Busy Flag &amp; Address

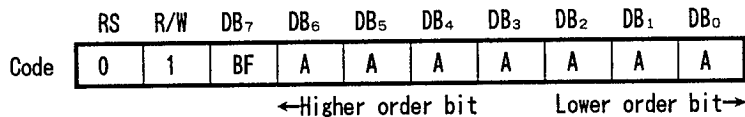

This instruction reads out the internal status of the NJU6461. When this instruction is executed, the busy flag (BF) stored in DB<sub>7</sub> and the address of the CG RAM or DD RAM stored in DB<sub>6</sub> to DB<sub>0</sub> are read out.

The (BF)="1" indicates that internal operation is in progress. The next instruction is inhibited when (BF)="1". Check the (BF) status before the next write operation.

(k) Write Data to CG RAM or DD RAM

• Write Data to DD RAM

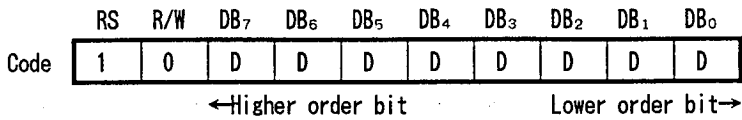

Write Data to DD RAM instruction is executed when the code "1" is written into (RS) and code "0" is written into (R/W).

By the execution of this instruction, the binary 8 bit data "DDDDDDDD" are written into the DD RAM. The selection of the DD RAM is determined by the previous instruction (DD RAM must be selected before). After this instruction execution, the address increment(+1) or decrement (-1) is performed automatically according to the entry mode set. And the display shift is also executed according to the previous entry mode set.

• Write Data to CG RAM

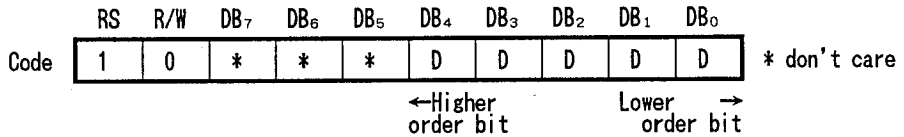

Write Data to CG RAM instruction is executed when the code "1" is written into (RS) and code "0" is written into (R/W).

By the execution of this instruction, the binary 5 bit data "DDDDD" are written into the CG RAM. The selection of the CG RAM is determined by the previous instruction (CG RAM must be selected before). After this instruction execution, the address increment(+1) or decrement (-1) is performed automatically according to the entry mode set. And the display shift is also executed according to the previous entry mode set.

## (1) Read Data from CG RAM or DD RAM

- Read Data from DD RAM

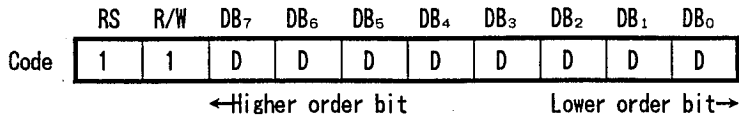

Read Data from DD RAM instruction is executed when the code "1" is written into (RS) and (R/W).

By the execution of this instruction, the binary 8 bit data "DDDDDDDD" are read out from the DD RAM.

- Read Data from CG RAM

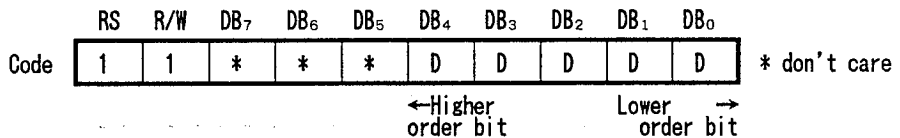

Read Data from CG RAM instruction is executed when the code "1" is written into (RS) and (R/W).

By the execution of this instruction, the binary 5 bit data "DDDDD" are read out from the CG RAM.

The CG RAM or DD RAM is determined by previous instruction.

Before executing this instruction, either the CG RAM address set or DD RAM address set must be executed, otherwise the first read out data are invalidated.

When this instruction is serially executed, the next address data is normally read from the second read.

The address set instruction is not required if the cursor shift instruction is executed just beforehand (only DD RAM reading).

The cursor shift instruction has same function as the DD RAM address set, so that after reading the DD RAM, the address increment or decrement is executed automatically according to the entry mode.

But display shift does not occur regardless of the entry mode.

Note: The address counter(AC) is automatically incremented or decremented by 1 after write instruction to either of the CG RAM or DD RAM. Even if the read instruction is executed after this instruction, the addressed data can not be read out correctly. For a correct data read out, either the address set instruction or cursor shift instruction (only with DD RAM) must be implemented just before this instruction or from the second time read out instruction execution if the read out instruction is executed 2 times consecutively.

5

### (3-2) Initialization using the internal reset circuits

#### (a) 8-bit operation (Using internal reset circuits).

The Function set, Display On/Off Control and Entry Set Instruction must be executed before the data input, as shown below.

The DD RAM of the NJU6461 can store up to 24 characters, as explained before, therefore the advertising moving display is available when combined with the display shift operation.

Since the display shift operation changes only display position and the DD RAM contents remain unchanged, display data which are entered first can be output when the return home operation is performed.

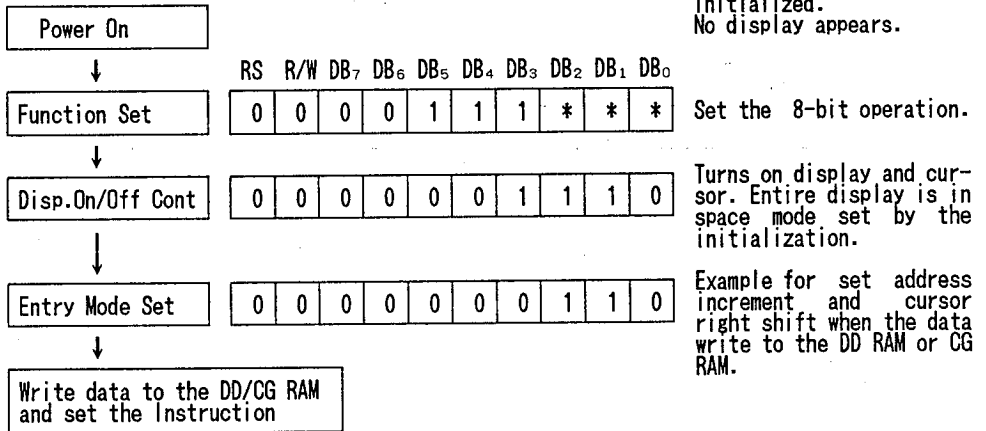

(b) 4-bit operation (Using internal reset circuits).

In the 4-bit operation, the function set must be performed by the user programming.

When the power is turned on, 8-bit operation is selected automatically, therefore the first input is performed under 8-bit operation. In this operation, full instruction can not input because of terminals DB<sub>0</sub> to DB<sub>3</sub> are no connection. Therefore, same instruction must be rewritten on the RS, R/W and DB<sub>7</sub> to DB<sub>4</sub>, as shown below. Since one operation is completed by the two accesses in the 4-bit operation mode, rewrite is required to set the instruction code in full.

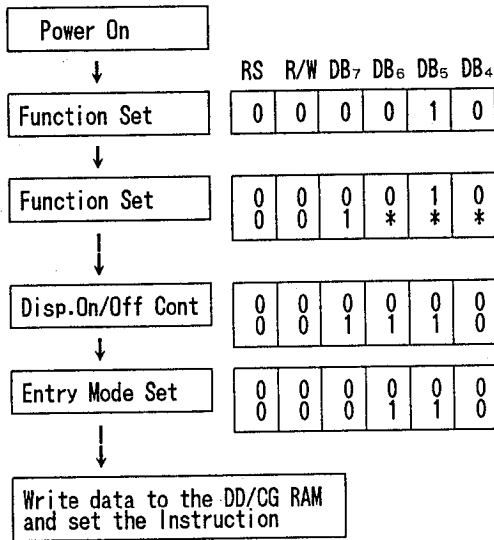

Initialized.  
No display appears.

Set the 4-bit operation.  
This step is executed in 8-bit mode set by the initialization.

Set the 4-bit operation.  
The 4-bit operation starts from this step.

Turn on display and cursor.  
Entire display is in space mode set by the initialization.

Example for set address increment and cursor right shift when the data write to the DD RAM or CG RAM.

**5**



### (3-3) Initialization by instruction

If the power supply conditions for the correct operation of the internal reset circuits are not met, the NJU6461 must be initialized by the instruction.

#### (a) Initialization by Instruction in 8-bit interface length.

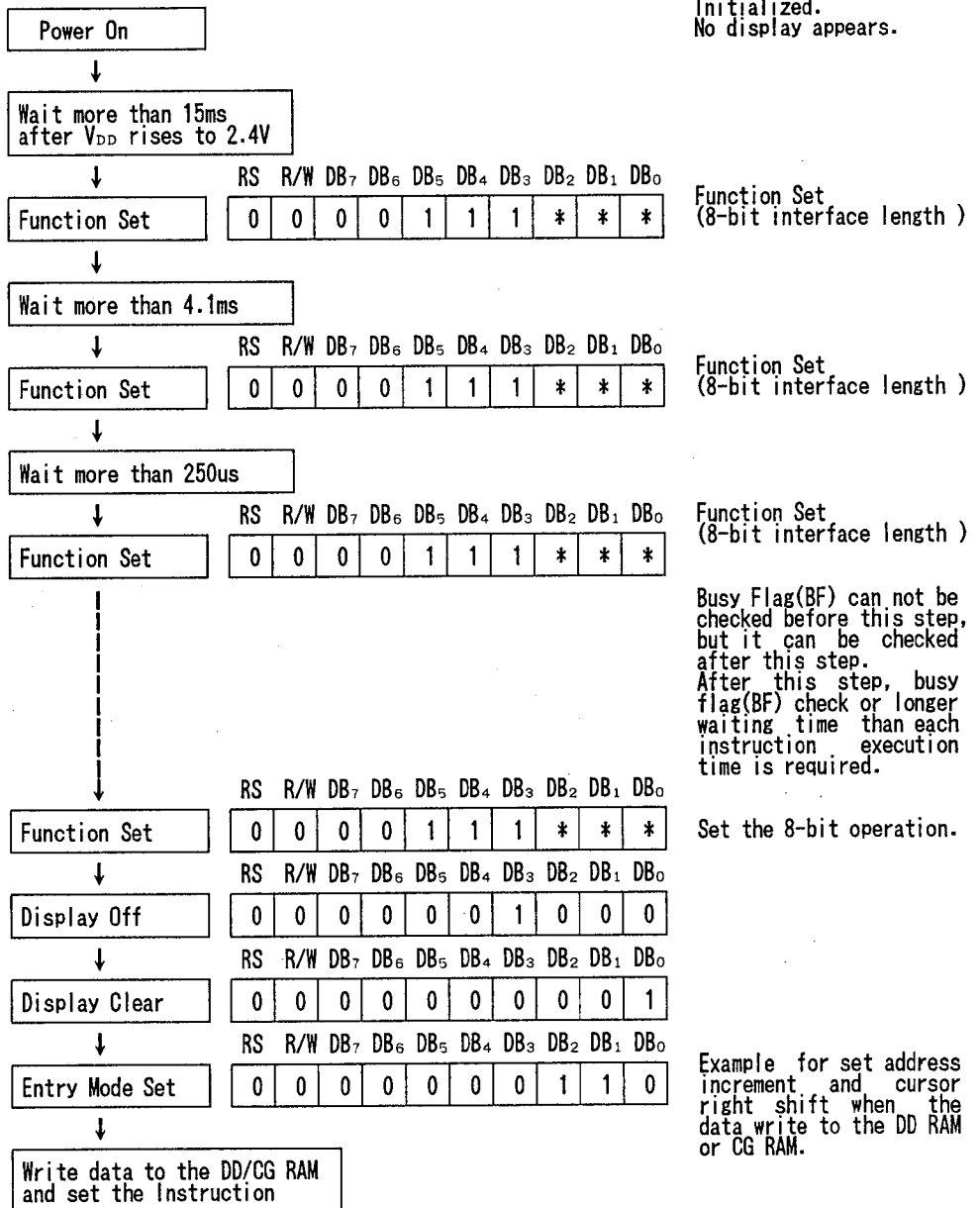

## (b) Initialization by Instruction in 4-bit interface length

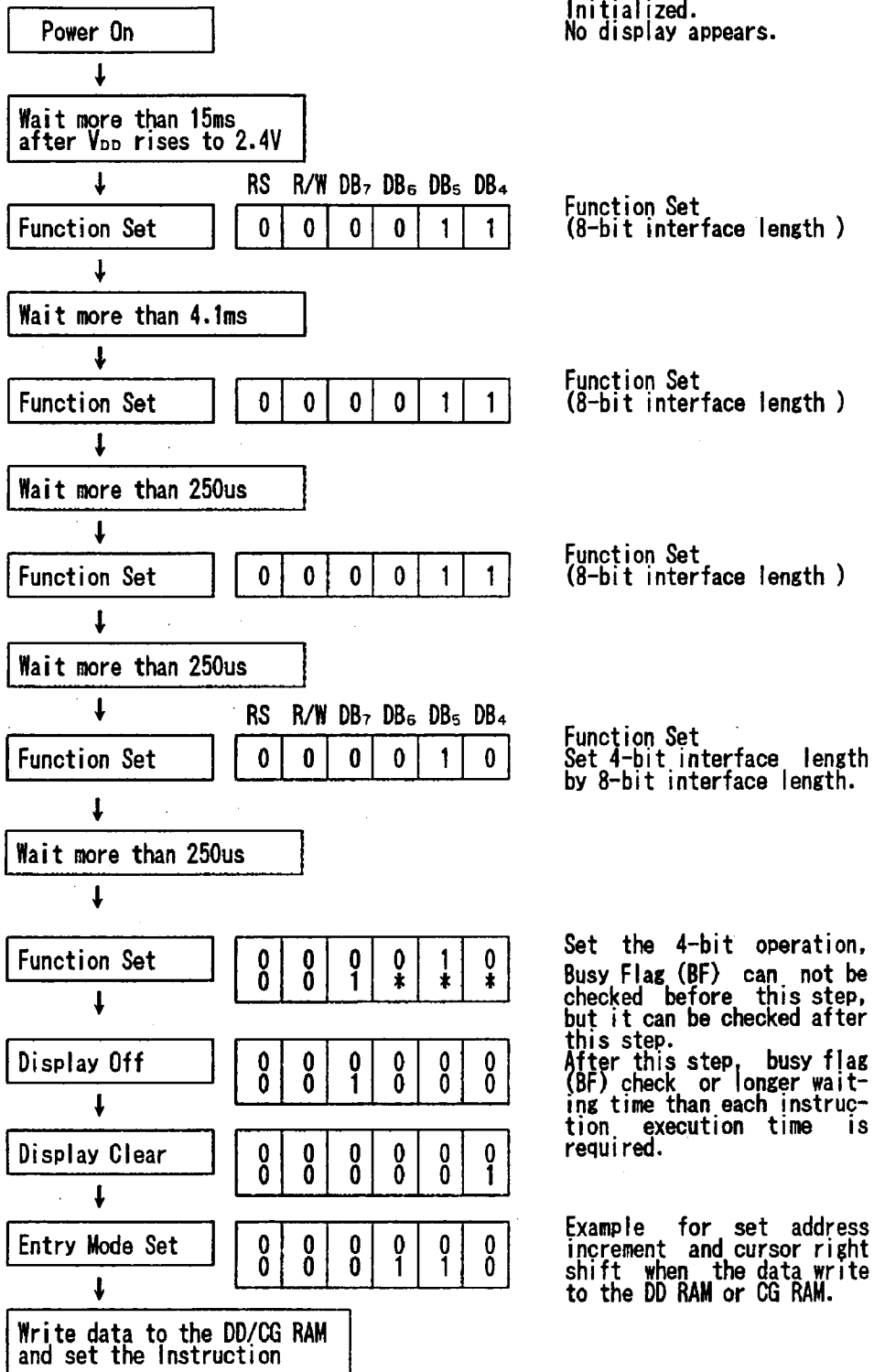

(4) LCD DISPLAY

(4-1) Power Supply for LCD Driving

NJU6461 incorporate voltage tripler to generate LCD driving high voltage and bleeder resistance. The voltage tripler generate about triple voltage from the  $V_{ci}$  input voltage ( $V_{LCD}=7.8V$  typ at  $I_{out}=100\mu A$  and  $V_{ci}=3V$ ) and bleeder resistance generate each LCD driving voltage. The bleeder resistance is set 1/5 bias suitable for 1/18 duty ratio and  $1.0M\Omega$  per resistance.

Furthermore, the bleeder resistance output the LCD Driving bias level through the voltage follower OP-AMP to get a enough display characteristics with low power consumption.

LCD Driving Voltage vs Duty Ratio

Power supply	Duty Ratio	1/18
	Bias	1/5
$V_{SOUT}$		$V_{DD}$ to $V_{LCD}$

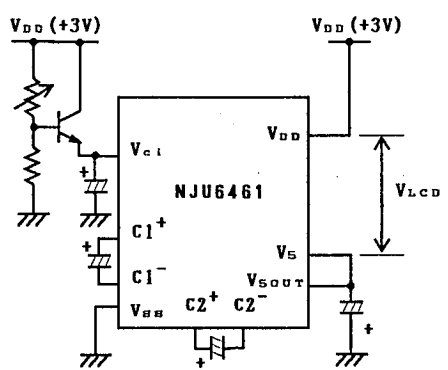

(a) 1/5 Bias(1/18 Duty)  
(Voltage Tripler used example)

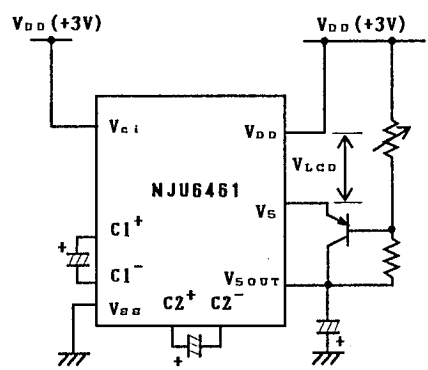

(b) 1/5 Bias(1/18 Duty)  
(Voltage Tripler used example)

Note ) The circuit value (resistors and transistor) should be designed, using the actual LCD panel.

(4-2) Relation between oscillation frequency and LCD frame frequency.

As the NJU6461 incorporate oscillation capacitor and resistance for CR oscillation, 80kHz oscillation is available without any external components.

The LCD frame frequency example mentioned below is based on 80kHz oscillation.  
(1 clock = 12.5us)

1/18 duty

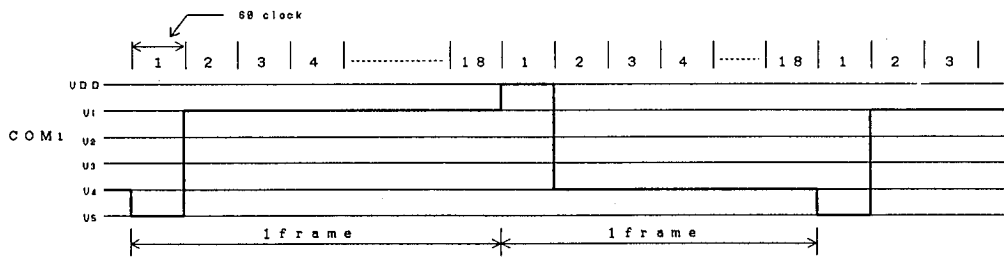

$$1 \text{ frame} = 12.5(\mu s) \times 60 \times 18 = 13.5(\text{ms})$$

$$\text{Frame frequency} = 1/13.5(\text{ms}) = 74.1(\text{Hz})$$

(5) Interface with MPU

NJU6461 can be interfaced with both of 4/8-bit MPU and the two-time 4-bit or one-time 8-bit data transfer is available.

(5-1) 4-bit MPU interface

When the interface length is 4-bit, the data transfer is performed by 4 lines connected to DB<sub>4</sub> to DB<sub>7</sub> (DB<sub>0</sub> to DB<sub>3</sub> are not used). The data transfer with the MPU is completed by the two-time 4-bit data transfer.

The data transfer is executed in the sequence of upper 4-bit (the data DB<sub>4</sub> to DB<sub>7</sub> at 8-bit length) and lower 4-bit (the data DB<sub>0</sub> to DB<sub>3</sub> at 8-bit length).

The busy flag check must be executed after two-time 4bit data transfer (1 instruction execution). In this case the data of busy flag and address counter are also output twice.

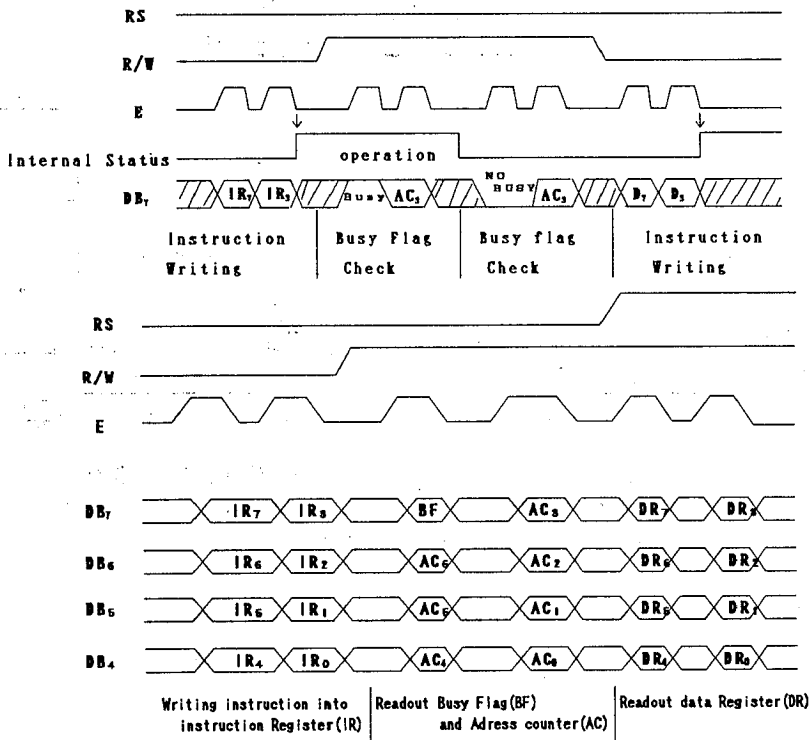

(5-2) 8-bit MPU interface

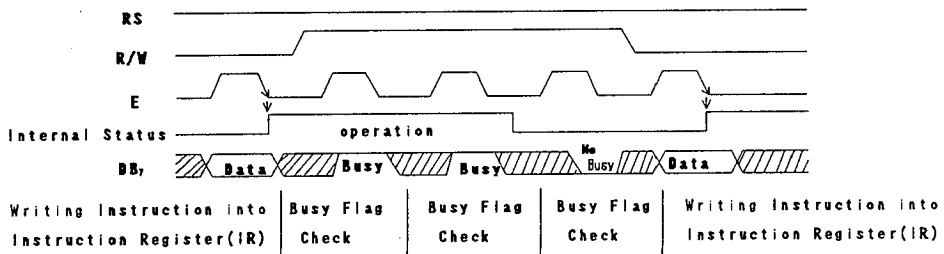

## (5-3) Serial interface

Serial interface circuit is activated when the P/S terminal is set to "L" level then the chip select terminal (CS) goes to "L" level. The data input/output is MSB first like as the order of DB<sub>7</sub>, DB<sub>6</sub>, ... DB<sub>0</sub>.

The input data is entered into the shift register synchronized at the rise edge of the serial clock SCL. The shift register converted to parallel data at the CS rise edge input. In case of entering over than 8-bit data, valid data is last 8-bit data.

The output data is exited from the shift register synchronized at the fall edge of the serial clock SCL.

The time chart for the serial interface is shown below.

Note: The level ("L" or "H") of RS and R/W terminals should be set before CS terminal goes to "L" level.

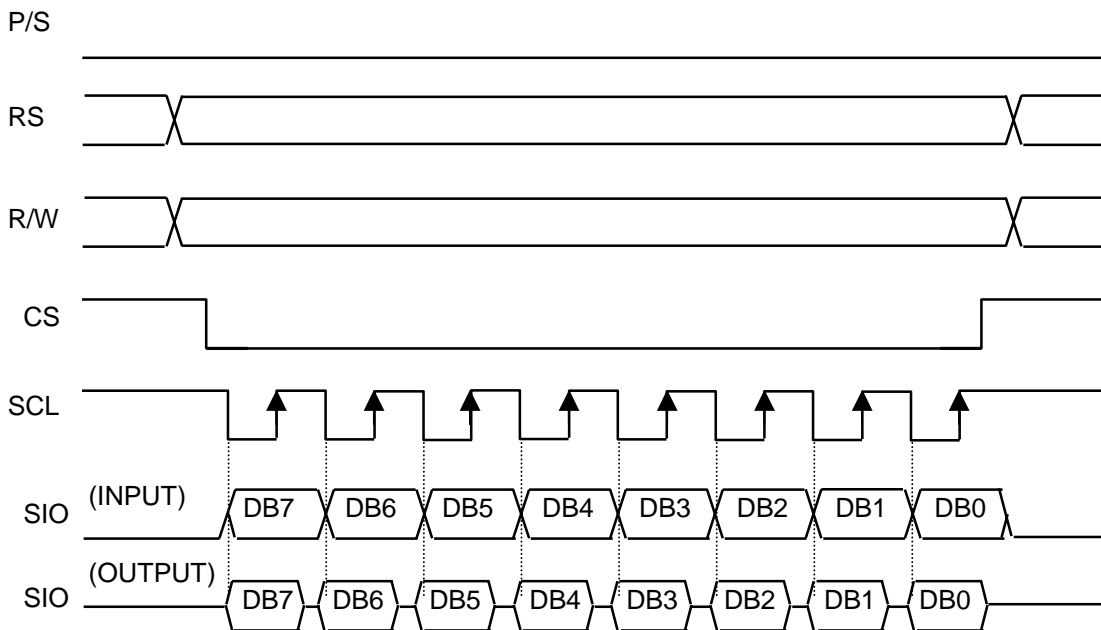

**■ ABSOLUTE MAXIMUM RATINGS**

( Ta=25°C )

PARAMETER	SYMBOL	RATINGS	UNIT
Supply Voltage (1)	V <sub>DD</sub>	- 0.3 ~ + 7.0	V
Input Voltage	V <sub>IN</sub>	- 0.3 ~ V <sub>DD</sub> +0.3	V
Operating Temperature	Topr	- 30 ~ + 80	°C
Storage Temperature	Tstg	- 55 ~ + 125	°C

Note 1) If the LSI are used on condition above the absolute maximum ratings, the LSI may be destroyed. Using the LSI within electrical characteristics is strongly recommended for normal operation. Use beyond the electric characteristics conditions will cause malfunction and poor reliability.

Note 2) Decoupling capacitor should be connected between V<sub>ci</sub> and V<sub>SS</sub> due to the stabilized operation for the Voltage Tripler (Doubler).

Note 3) All voltage values are specified as V<sub>SS</sub> = 0V

Note 4) The relation : V<sub>DD</sub> ≥ V<sub>ci</sub> > V<sub>SS</sub> , V<sub>DD</sub> > V<sub>SS</sub> ≥ V<sub>5OUT</sub> , V<sub>SS</sub>=0V must be maintained.

Turn on V<sub>DD</sub> and V<sub>ci</sub> at same time or turn on V<sub>DD</sub> first then turn on V<sub>ci</sub> must be required. If the turn on sequence does not meet above conditions, latch up will occur.

**■ ELECTRICAL CHARACTERISTICS**

 ( V<sub>DD</sub>=3V±20% , Ta=-20 ~ +75°C )

PARAMETER		SYMBOL	CONDITIONS	MIN	TYP	MAX	UNIT	NOTE
Operating Voltage		V <sub>DD</sub>		2.4	3.0	3.6	V	
Input Voltage		V <sub>IH</sub>		0.8V <sub>DD</sub>		V <sub>DD</sub>	V	5
		V <sub>IL</sub>				0.2V <sub>DD</sub>		
Output Voltage		V <sub>OH</sub>	-I <sub>OH</sub> =0.205mA	2.0			V	6
		V <sub>OL</sub>	I <sub>OL</sub> =1.6mA			0.5		
Driver On-resist.(COM)		R <sub>COM</sub>	±I <sub>d</sub> =50uA (All com term.)			20	kΩ	9
Driver On-resist.(SEG)		R <sub>SEG</sub>	±I <sub>d</sub> =50uA (All seg term.)			30		
Input Leakage Current		I <sub>LI</sub>	V <sub>IN</sub> =0 ~ V <sub>DD</sub>	- 1		1	uA	7
Pull-up Resist Current		-I <sub>P</sub>	V <sub>DD</sub> =3V, RS,R/W,RESET,DB Terminals	10	25	50	uA	
Operating Current		I <sub>DD</sub>	V <sub>DD</sub> =3V, f <sub>OSC</sub> =Internal freq		95	150	uA	8
Voltage Converter (Tripler)	Output Voltage	V <sub>UP</sub>	V <sub>ci</sub> =3V, I <sub>OUT</sub> =100uA, Ta=25°C	- 4.6	- 4.8		V	
	Input Voltage	V <sub>ci</sub>		2.6		V <sub>DD</sub>	V	
	Conversion Efficiency	V <sub>ef</sub>	R <sub>L</sub> =∞	95.0	99.9		%	
Bleeder resistance		R <sub>B</sub>	V <sub>DD</sub> -V <sub>S</sub> =3V		5.0		MΩ	
Oscillation Frequency		f <sub>OSC</sub>	V <sub>DD</sub> =3V, Ta=25°C	56	80	104	kHz	
LCD Driving Voltage		V <sub>LCD</sub>	V <sub>5OUT</sub> Terminal, V <sub>DD</sub> =3V	V <sub>DD</sub> - 3.0		V <sub>DD</sub> - 13.5	V	10
Output Current		I <sub>S</sub>	V <sub>DD</sub> =V <sub>ci</sub> =3V			100	uA	

Note 5) Input/Output structure except LCD driver are shown below:

Input Terminal Structure

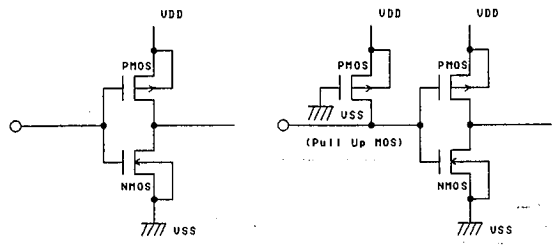

Input/Output Terminal Structure

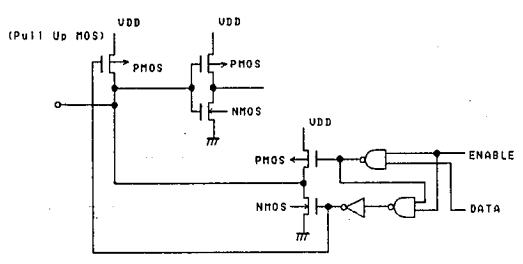

E Terminal

RS,R/W Terminals

DB<sub>0</sub> to DB<sub>7</sub> Terminals

Note 6) Apply to the Output and Input/Output Terminal.

Note 7) Except pull-up resistance current and output driver current.

Note 8) Except input/output current but including the current flow on bleeder resistance.

If the input level is medium, current consumption will increase due to the penetration current. Therefore, the input level must be fixed to "H" or "L".

Operating Current Measurement Circuit

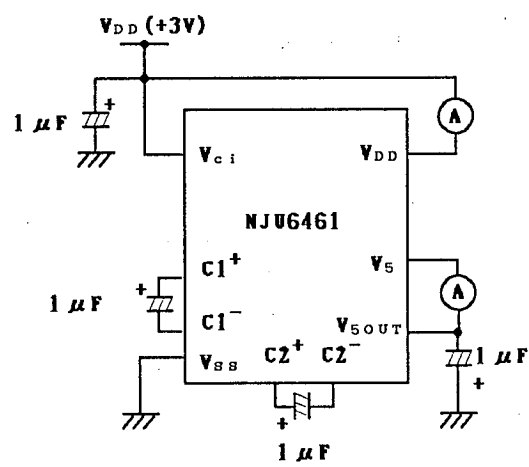

Note 9)  $R_{COM}$  and  $R_{SEG}$  are the resistance values between power supply terminals ( $V_{DD}$ ,  $V_{SOUT}$  or  $V_1$ ,  $V_2$ ,  $V_3$ ,  $V_4$ ) and each common terminal ( $COM_1$  to  $COM_{16}$  /  $COMM1$ ,  $COMM2$ ) and supply voltage ( $V_{DD}$ ,  $V_{SOUT}$  or  $V_1$ ,  $V_2$ ,  $V_3$ ,  $V_4$ ) and each segment terminal ( $SEG_1$  to  $SEG_{60}$ ) respectively, and measured when the current  $I_d$  is flown on every common and segment terminals at a same time.

Note 10) Apply to the output voltage from each COM and SEG are less than  $\pm 0.15V$  against the LCD driving constant voltage ( $V_{DD}$ ,  $V_{SOUT}$ ) at no load condition.

**Voltage Tripler Measurement Circuit**

**Voltage Doubler Measurement Circuit**

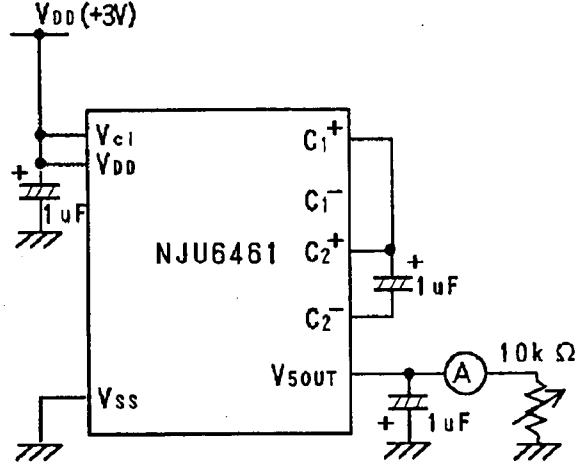
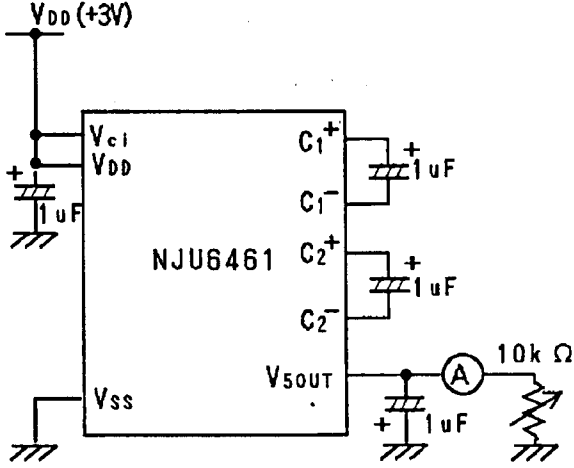

Voltage Tripler/Doubler  
Operation Clock Frequency = 1.25kHz (fosc=80kHz)

**5**

**Bleeder Resistance and Buffer Amplifier**

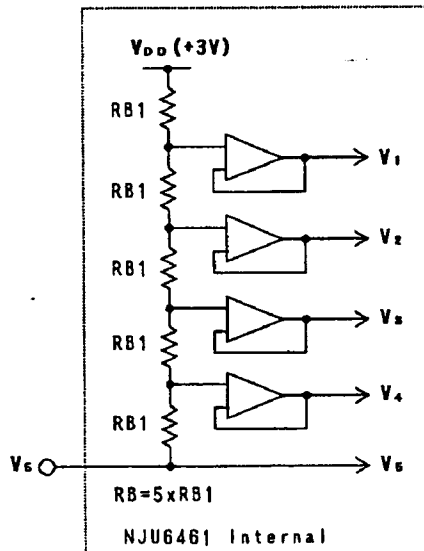



- Bus timing characteristics ( $V_{DD} = 3.0V \pm 20\%$ ,  $V_{SS} = 0V$ ,  $T_a = -20 \sim +75^\circ C$ )

Write operation ( Write from MPU to NJU6461 )

PARAMETER		SYMBOL	MIN	MAX	CONDITION	UNIT
Enable Cycle Time		$t_{CYCE}$	1		fig.1	us
Enable Pulse Width	"High" level	$P_{WEH}$	400			
Enable Rise Time, Fall Time		$t_{Er}$ , $t_{Ef}$		20		
Set up Time	RS, R/W, E	$t_{AS}$	40			ns
Address Hold Time		$t_{AH}$	20			
Data Set up Time		$t_{DSW}$	70			
Data Hold Time		$t_H$	40			

Timing Characteristics (Write operation)

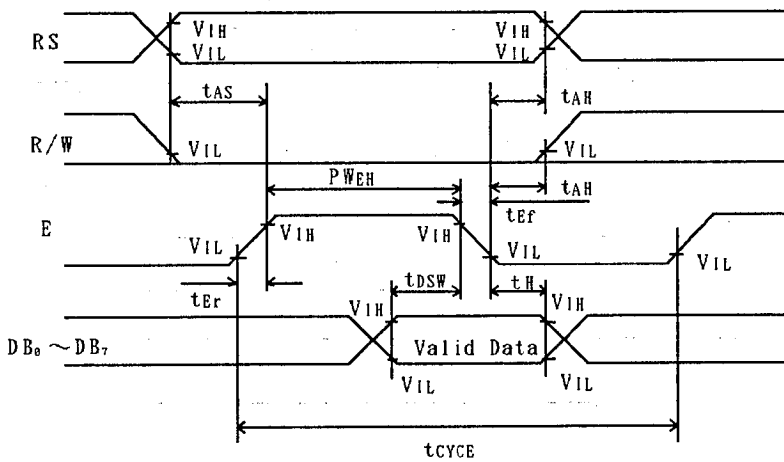

fig. 1

Read operation ( Read from NJU6461 to MPU )

PARAMETER	SYMBOL	MIN	MAX	CONDITION	UNIT
Enable Cycle Time	$t_{CYCE}$	1		fig.2	us
Enable Pulse Width "High" level	$P_{WEH}$	700			ns
Enable Rise Time, Fall Time	$t_{Er}, t_{Ef}$		20		
Set up Time RS, R/W, E	$t_{AS}$	40			
Address Hold Time	$t_{AH}$	20			
Data Delay Time	$t_{DDW}$		700		
Data Hold Time	$t_{DDH}$	40			

 Load Condition of  $DB_0$  to  $DB_7$  :  $CL=100pF$ 

Timing Characteristics (Read operation)

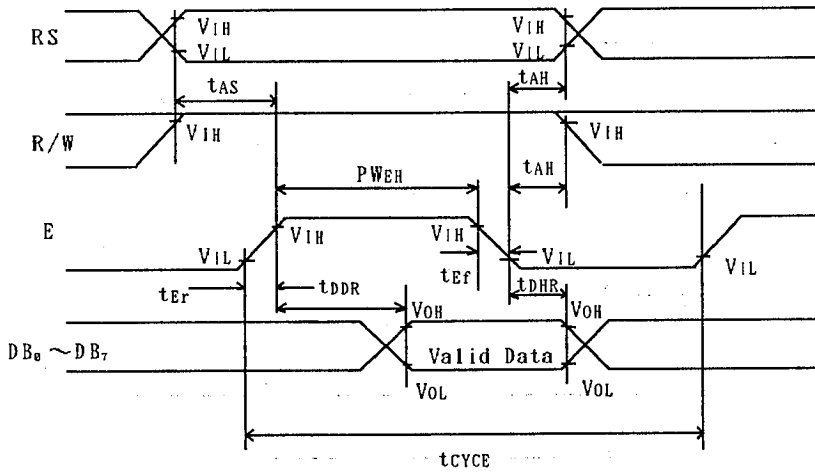

fig. 2

5

## • Serial Interface Sequence

 $(V_{DD}=2.4\sim 3.6V, V_{SS}=0V, T_a=-20\sim +75^{\circ}C)$ 

PARAMETER		SYMBOL	MIN	MAX	CONDITION	UNIT
Serial Clock Cycle Time		$t_{CYCE}$	1		fig.3	$\mu s$
Serial Clock Width	"High" level	$t_{SCH}$	300			ns
	"LOW" level	$t_{SCL}$	700			ns
Serial Clock rise and fall Time		$t_{SCR}, t_{SCF}$		20		ns
Chip Select Pulse Width		$PW_{CS}$	500			ns
Chip Select Setup Time		$t_{CSU}$	200			ns
Chip Select Hold Time		$t_{CH}$	200			ns
Chip Select rise and fall Time		$t_{CSR}, t_{CSF}$		20		ns
Setup Time	RS, R/W - CS	$t_{AS}$	300			ns
Address Hold Time		$t_{AH}$	200			ns
Serial Input Data Setup Time		$t_{SISU}$	200			ns
Serial Input Data Hold Time		$t_{SIH}$	200			ns
Serial Output Data Delay Time		$t_{SOD}$		700		ns
Serial Output Data Hold Time		$t_{SOH}$	200			ns

## Serial Interface

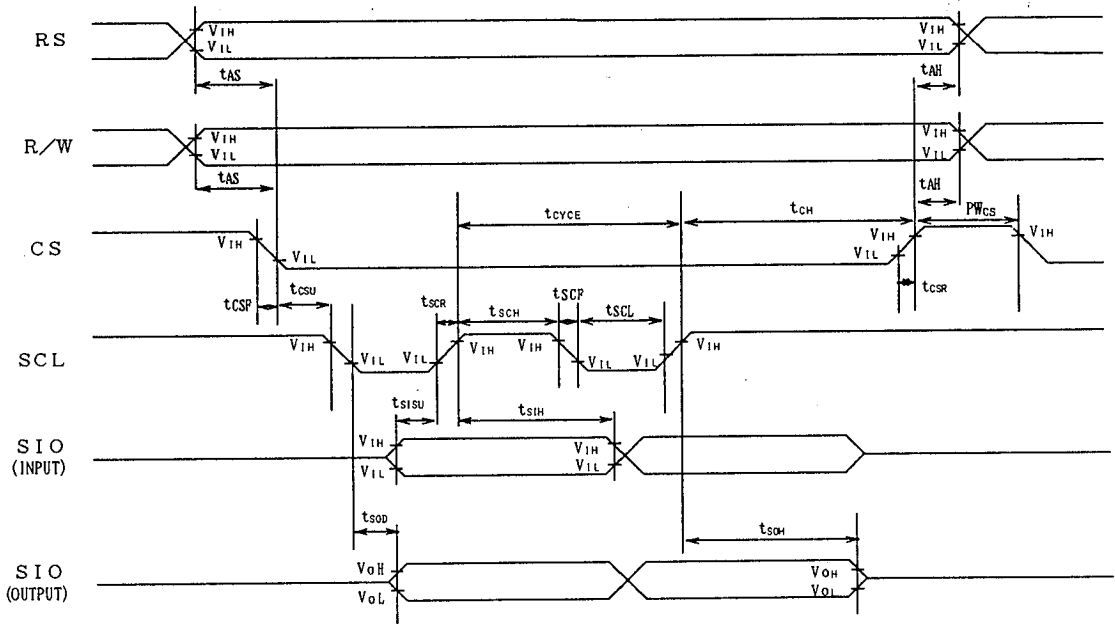
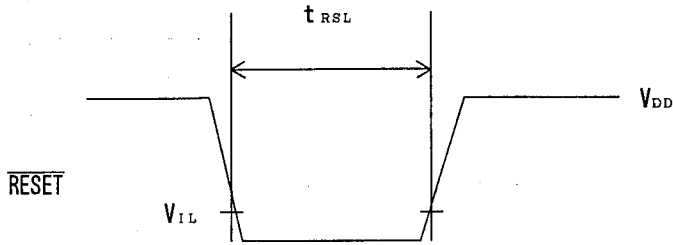

fig. 3

•The Input Condition when using the Hardware Reset Circuit

Input Timing



PARAMETER	SYMBOL	CONDITION	MIN	MAX	UNIT
Reset Input "L" Level Width	$t_{RSL}$	$f_{OSC}=80kHz$	1.2	-	ms

•Power Supply Condition when using the internal initialization circuit( $T_a = -20 \sim +75^{\circ}C$ )

PARAMETER	SYMBOL	CONDITION	MIN	MAX	UNIT
Power Supply Rise Time	$t_{rDD}$		0.1	5	ms
Power Supply OFF Time	$t_{OFF}$		1		

Since the internal initialization circuits will not operate normally unless the above conditions are met, in such a case initialize by instruction.  
(Refer to initialization by the instruction)

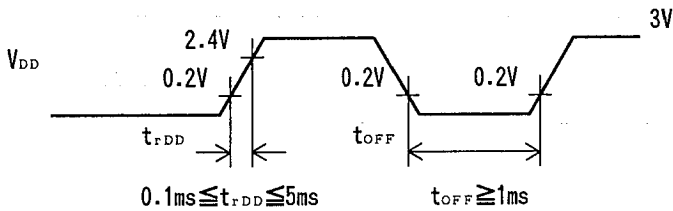

$t_{OFF}$  specifies the power off time in a short period off or cyclical on/off.

# NJU6461

## ■ LCD DRIVING WAVE FORM

1/18 Duty Driving

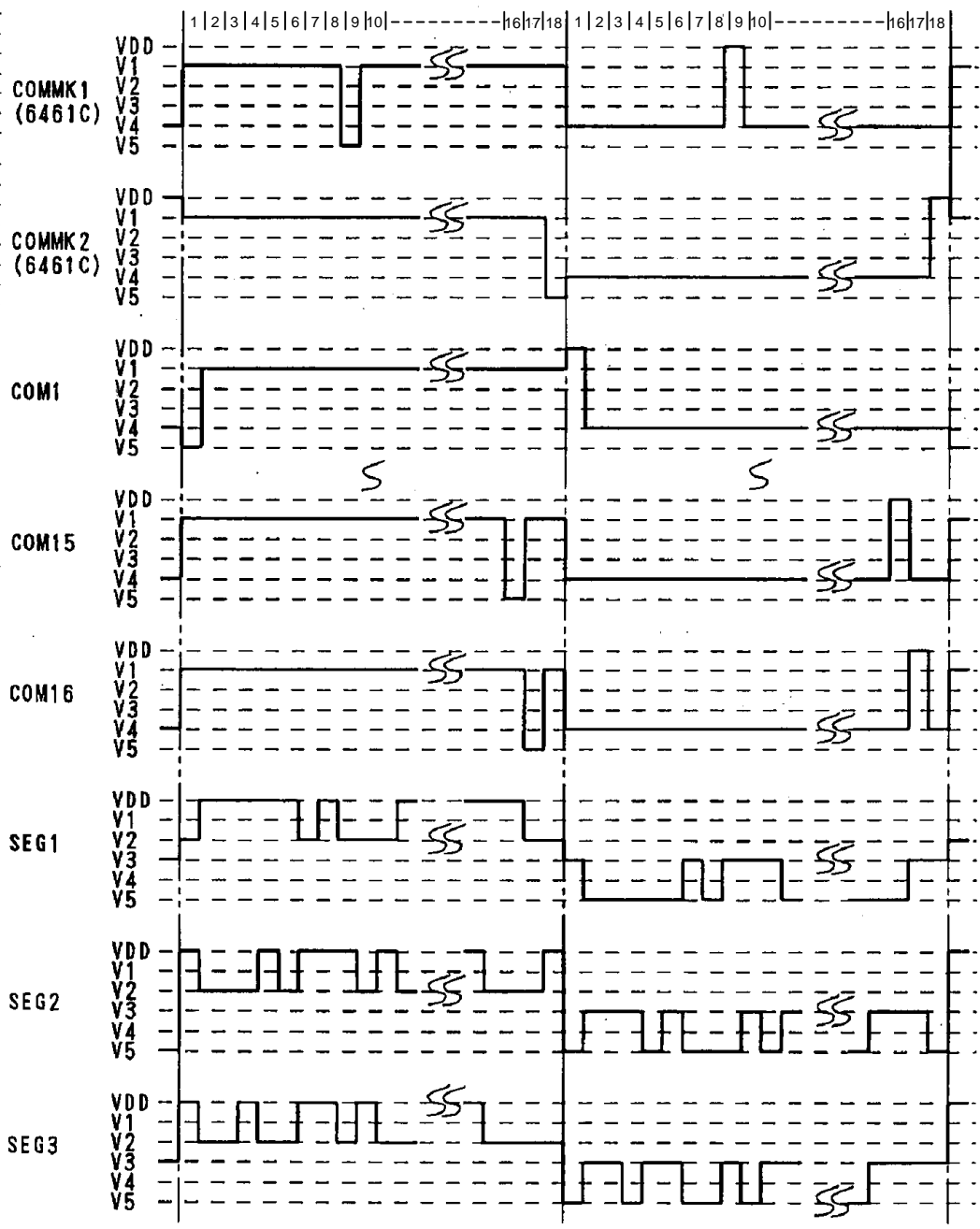
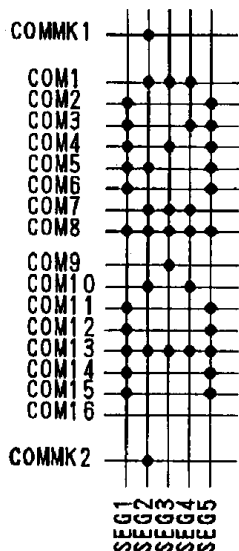

■ APPLICATION CIRCUITS ( 1 )

- 12-character 2-line with Icon Display Example

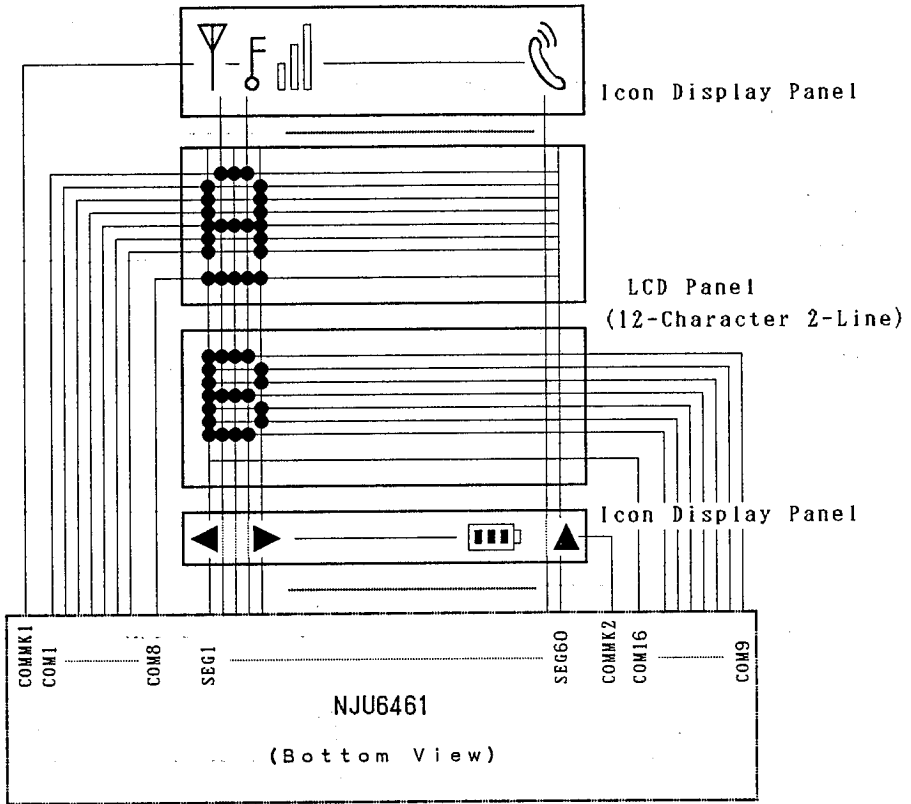

Note : One segment line can apply only one Icon Display.  
Please don't use same segment line for both of upper and lower Icon display.

**5**

# NJU6461

## APPLICATION CIRCUITS (2)

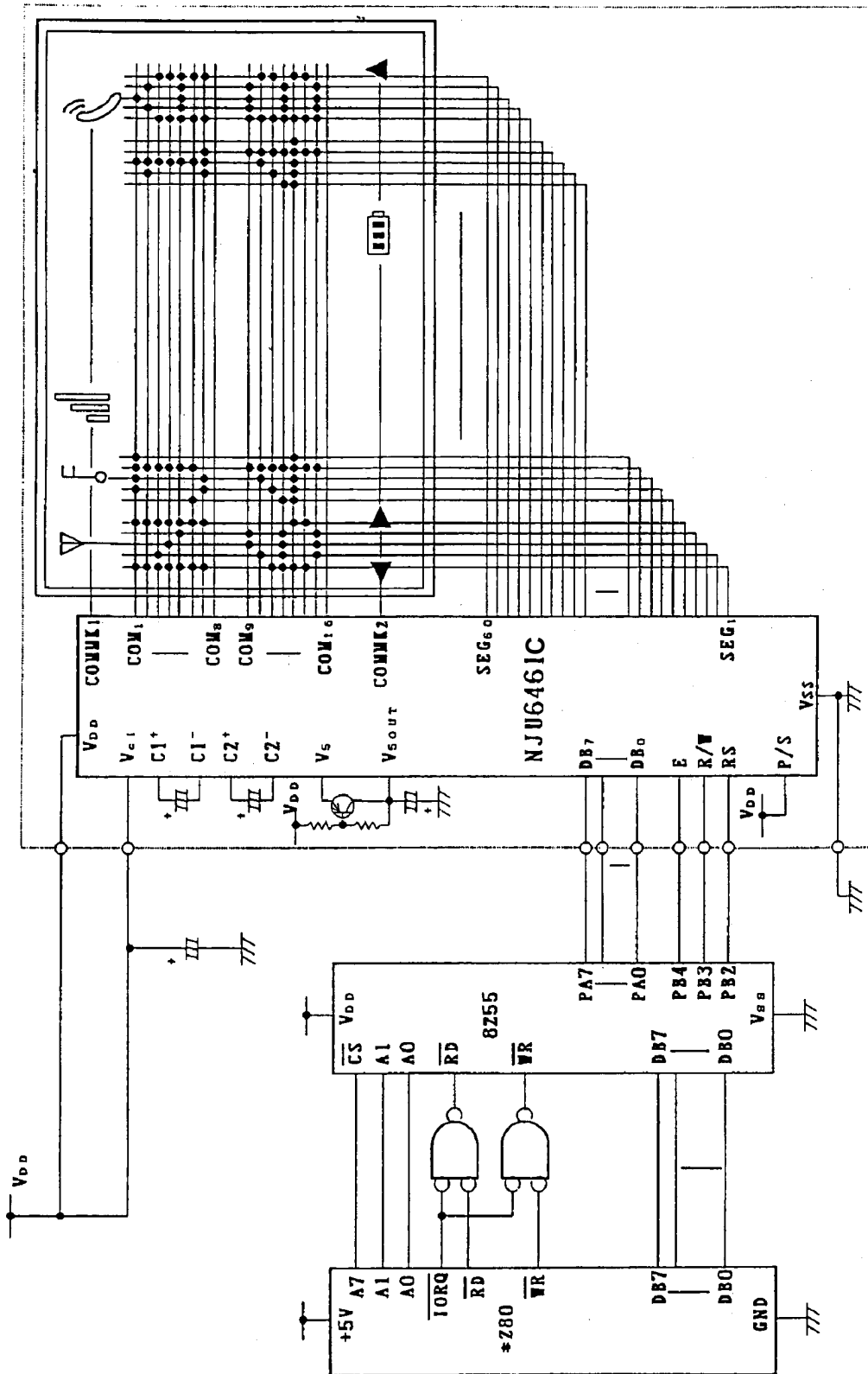

\*Z80® is trade mark of Zilog Inc.

8 bit MPU interface example (Using the NJU6461C)

## APPLICATION CIRCUITS (3)

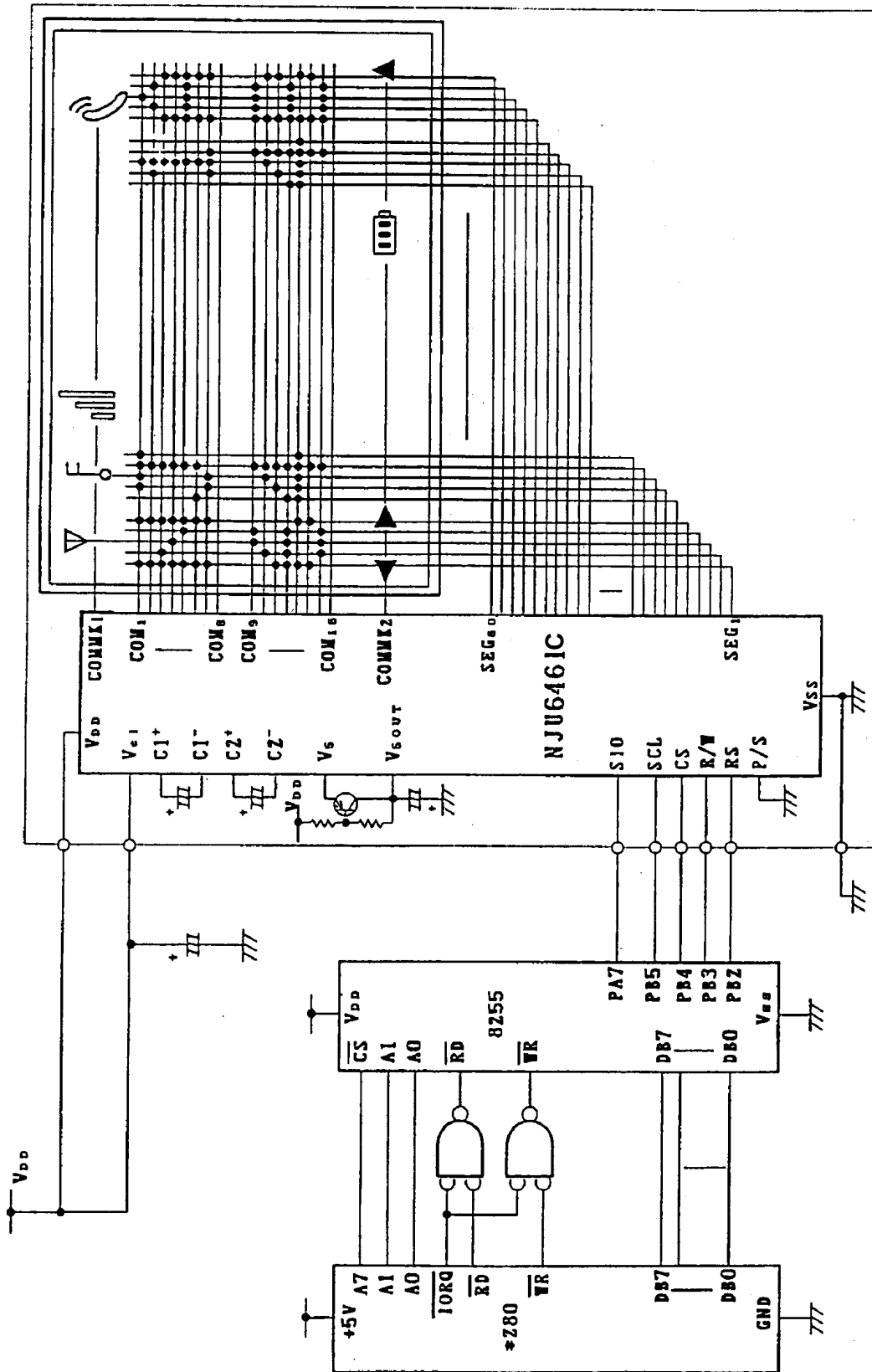

\*Z80® is trade mark of Zilog Inc.

Serial interface example (Using the NJU6461C)



---

# MEMO

**[CAUTION]**

The specifications on this databook are only given for information, without any guarantee as regards either mistakes or omissions. The application circuits in this databook are described only to show representative usages of the product and not intended for the guarantee or permission of any right including the industrial rights.