

## SPDT SWITCH GaAs MMIC

### ■ GENERAL DESCRIPTION

The NJG1600KB2 is a GaAs SPDT switch IC that features small-sized package and low insertion loss, and ideally suited for T/R switch of digital cordless telephone or other digital wireless systems.

This switch is operated in the wide frequency range from 100MHz to 2.5GHz at low operating voltage from +2.5V.

The ultra small & ultra thin FLP6-B2 package is adopted.

### ■ PACKAGE OUTLINE



NJG1600KB2

### ■ FEATURES

- Low insertion loss
  - 0.35dB typ. @f=1.0GHz
  - 0.40dB typ. @f=2.0GHz
  - 0.45dB typ. @f=2.5GHz
- High isolation
  - 27dB typ. @f=1.0GHz
  - 22dB typ. @f=2.0GHz
  - 20dB typ. @f=2.5GHz
- Pin at 1dB compression point
  - 28dBm typ. @f=2.5GHz
- Low control current
  - 5uA typ. @0.1~2.5GHz
- Ultra small & ultra thin package
  - FLP6-B2 (Package size: 2.1x2.0x0.75mm)

### ■ PIN CONFIGURATION

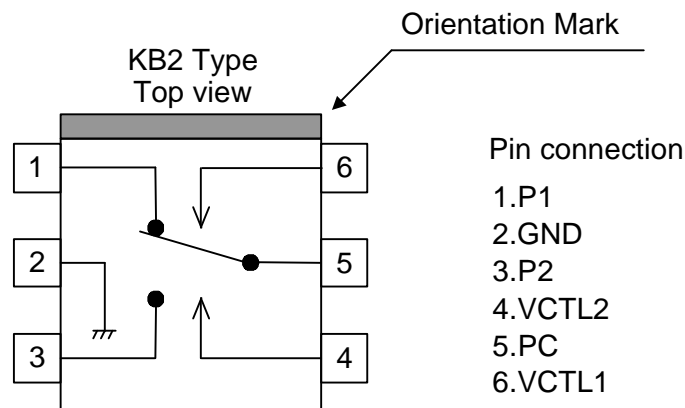

### ■ TRUTH TABLE

“H”= $V_{CTL(H)}$ , “L”= $V_{CTL(L)}$

VCTL1	H	L
VCTL2	L	H
PC-P1	OFF	ON
PC-P2	ON	OFF

Note: Reversed logic version of this device is NJG1542KB2.

# NJG1600KB2

## ■ ABSOLUTE MAXIMUM RATINGS

PARAMETER	SYMBOL	CONDITIONS	CONDITIONS	UNITS
RF Input Power	$P_{IN}$	$V_{CTL}=0V/3V$	29	dBm
Control Voltage	$V_{CTL}$	VCTL terminal	7.5	V
Power Dissipation	$P_D$		450	mW
Operating Temp.	$T_{opr}$		-40~+85	°C
Storage Temp.	$T_{stg}$		-55~+150	°C

## ■ ELECTRICAL CHARACTERISTICS

(General conditions:  $V_{CTL(L)}=0V$ ,  $V_{CTL(H)}=3V$ ,  $Z_S=Z_L=50\Omega$ ,  $T_a=25^\circ C$ )

PARAMETERS	SYMBOL	CONDITIONS	MIN	TYP	MAX	UNITS
Control Voltage (LOW)	$V_{CTL(L)}$		-0.2	-	0.2	V
Control Voltage (HIGH)	$V_{CTL(H)}$		2.5	3	6.5	V
Control Current	$I_{CTL}$	$f=2.5GHz$ , $P_{IN}=18dBm$	-	5	10	$\mu A$
Insertion Loss 1	LOSS1	$f=1.0GHz$ , $P_{IN}=18dBm$	-	0.35	0.5	dB
Insertion Loss 2	LOSS2	$f=2.0GHz$ , $P_{IN}=18dBm$	-	0.40	0.55	dB
Insertion Loss 3	LOSS3	$f=2.5GHz$ , $P_{IN}=18dBm$	-	0.45	0.6	dB
Isolation 1	ISL1	$f=1.0GHz$ , $P_{IN}=18dBm$	24	27	-	dB
Isolation 2	ISL2	$f=2.0GHz$ , $P_{IN}=18dBm$	19	22	-	dB
Isolation 3	ISL2	$f=2.5GHz$ , $P_{IN}=18dBm$	17	20	-	dB
Pin at 1dB Compression Point 1	$P_{-1dB(1)}$	$f=2.5GHz(V=0V/2.7V)$	24.5	26	-	dBm
Pin at 1dB Compression Point 2	$P_{-1dB(2)}$	$f=2.5GHz$	26	28	-	dBm
VSWR	VSWR	$f=0.1\sim 2.5GHz$ , ON state	-	1.1	1.3	
Switching time	$T_{SW}$	$f=0.1\sim 2.5GHz$	-	20	100	ns

## ■ TERMINAL INFORMATION

No.	SYMBOL	DESCRIPTION
1	P1	RF port. This port is connected with PC port by controlling 4 <sup>th</sup> pin ( $V_{CTL(H)}$ ) to 2.5~6.5V and 6 <sup>th</sup> pin ( $V_{CTL(L)}$ ) to -0.2~+0.2V. An external capacitor is required to block the DC bias voltage of internal circuit. (50~100MHz:0.01uF, 0.1~0.5GHz: 1000pF, 0.5~2.5GHz: 56pF)
2	GND	Ground terminal. Please connect this terminal with ground plane as close as possible for excellent RF performance.
3	P2	RF port. This port is connected with PC port by controlling 6 <sup>th</sup> pin ( $V_{CTL(H)}$ ) to 2.5~6.5V and 4 <sup>th</sup> pin ( $V_{CTL(L)}$ ) to -0.2~+0.2V. An external capacitor is required to block the DC bias voltage of internal circuit. (50~100MHz:0.01uF, 0.1~0.5GHz: 1000pF, 0.5~2.5GHz: 56pF)
4	VCTL2	Control port 2. The voltage of this port controls PC to P1 state. The 'ON' and 'OFF' state is toggled by controlling voltage of this terminal such as high-state (2.5~6.5V) or low-state (-0.2~+0.2V). The voltage of 6 <sup>th</sup> pin have to be set to opposite state. The bypass capacitor has to be chosen to reduce switching time delay from 10pF~1000pF range.
5	PC	Common RF port. In order to block the DC bias voltage of internal circuit, an external capacitor is required. (50~100MHz:0.01uF, 0.1~0.5GHz: 1000pF, 0.5~2.5GHz: 56pF)
6	VCTL1	Control port 1. The voltage of this port controls PC to P2 state. The 'ON' and 'OFF' state is toggled by controlling voltage of this terminal such as high-state (2.5~6.5V) or low-state (-0.2~+0.2V). The voltage of 4 <sup>th</sup> pin have to be set to opposite state. The bypass capacitor has to be chosen to reduce switching time delay from 10pF~1000pF range.

# NJG1600KB2

## ELECTRICAL CHARACTERISTICS

(0.1~3.0GHz, with application circuit, without DC Blocking Capacitor, Losses of external circuit are excluded)

### PC-P1 Insertion Loss vs. Frequency

(VCTL=3.0V/0V)

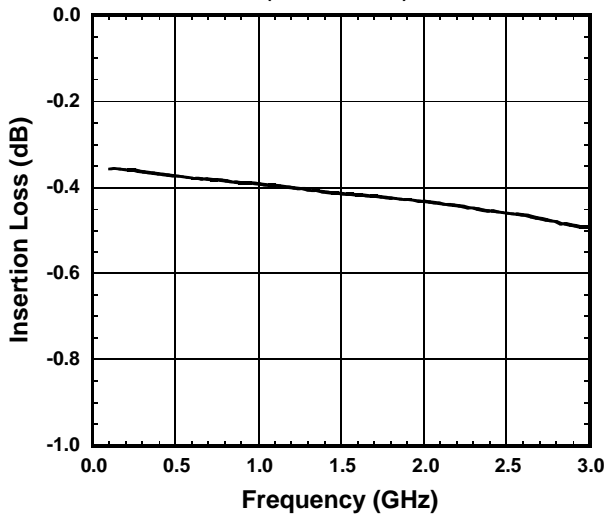

### PC-P2 Insertion Loss vs. Frequency

(VCTL=3.0V/0V)

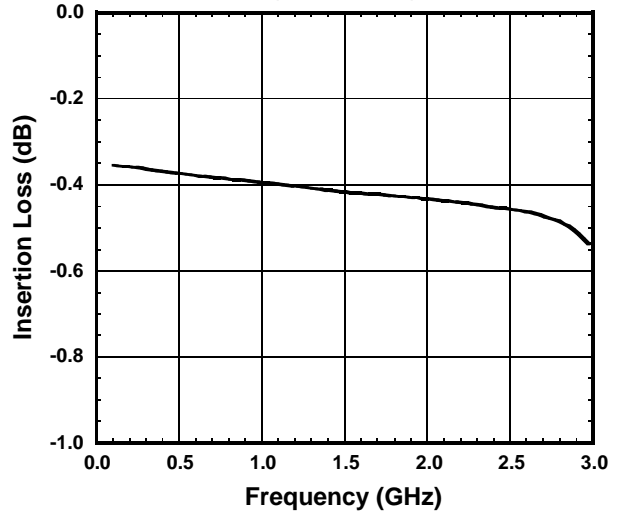

### PC-P1 Isolation vs. Frequency

(VCTL=3.0V/0V)

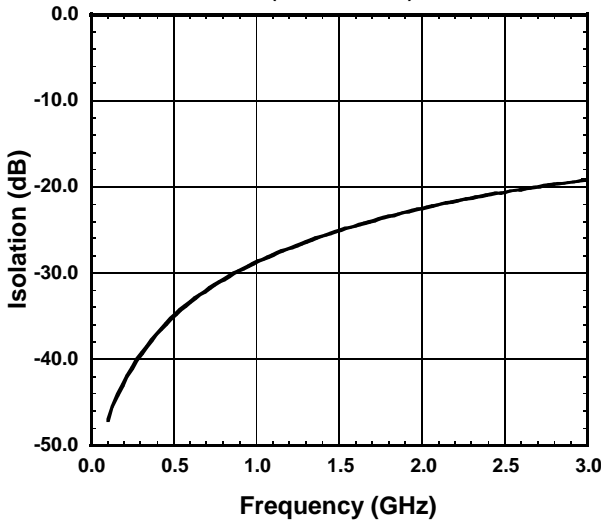

### PC-P2 Isolation vs. Frequency

(VCTL=3.0V/0V)

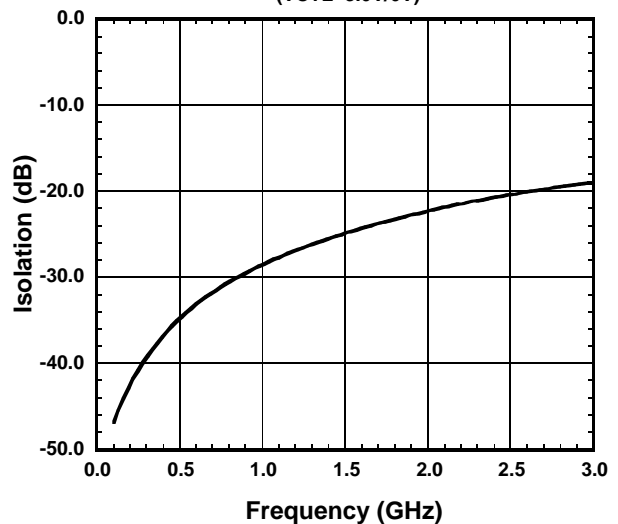

### PC-P1 VSWR vs. Frequency

(VCTL=3.0V/0V, P1 port)

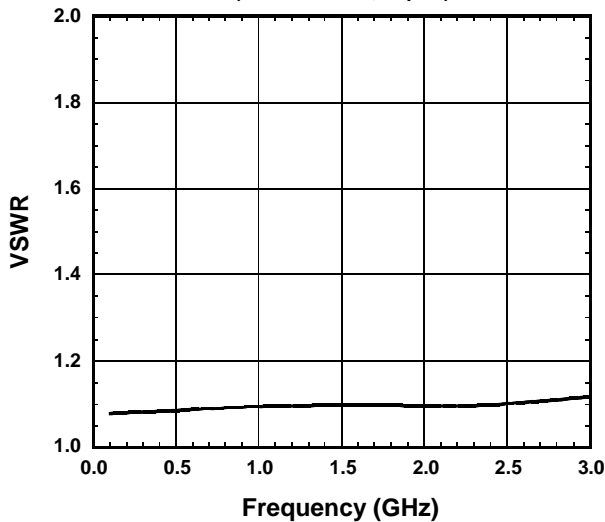

### PC-P2 VSWR vs. Frequency

(VCTL=3.0V/0V, P2 port)

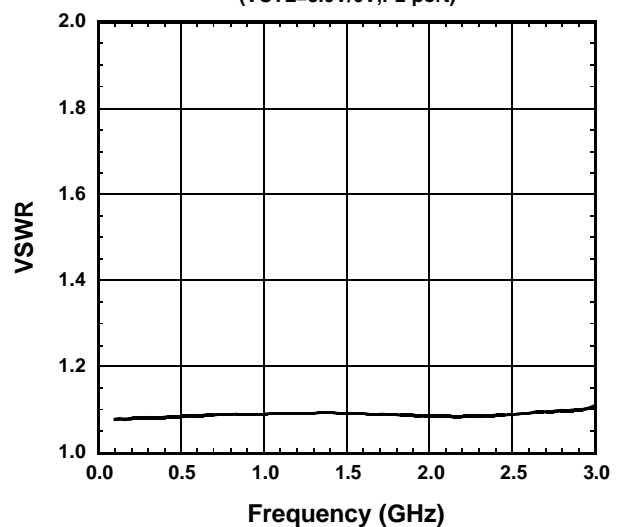

## ELECTRICAL CHARACTERISTICS

(Application circuit (Parts list 2))

### Insertion Loss vs. Input Power

(PC-P1 ON, f=2.5GHz)

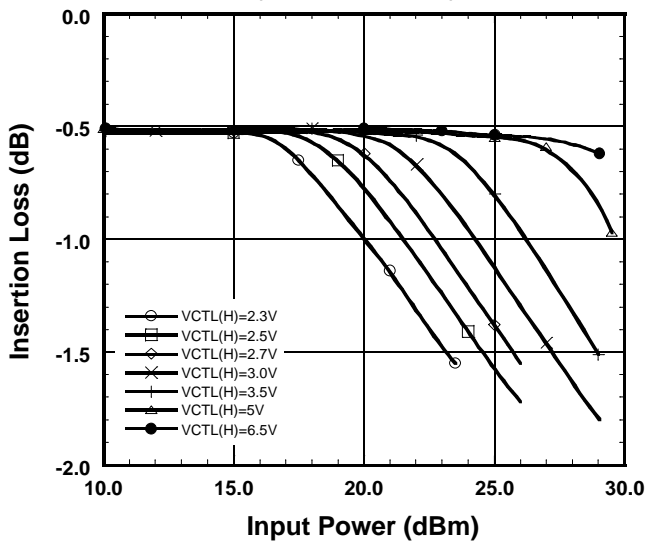

### Input Power vs. Output Power, ICTL

(VCTL=3.0V/0V, f=2.5GHz)

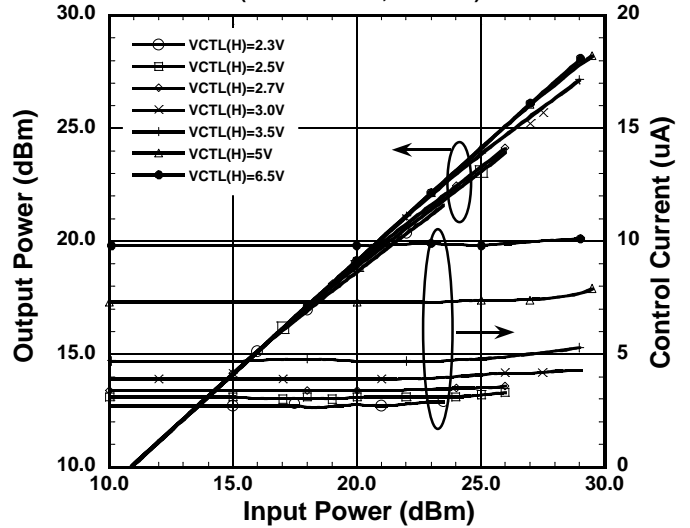

### PC-P1 Insertion Loss vs. Ambient Temperature

(PC-P1 ON, f=2.5GHz, Pin=18dBm)

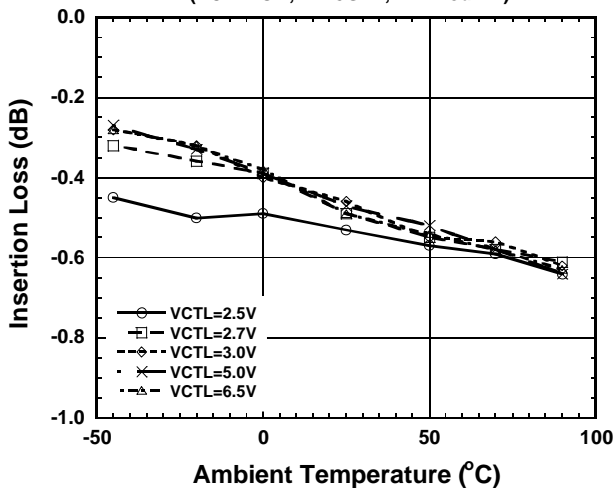

### PC-P2 Isolation vs. Ambient Temperature

(PC-P1 ON, VCTL=3.0V/0V, f=2.5GHz, Pin=18dBm)

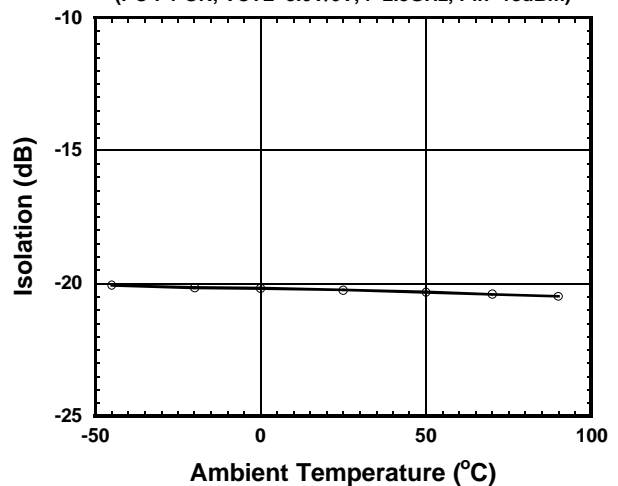

### PC-P1 P-1dB vs. Ambient Temperature

(PC-P1 ON, f=2.5GHz)

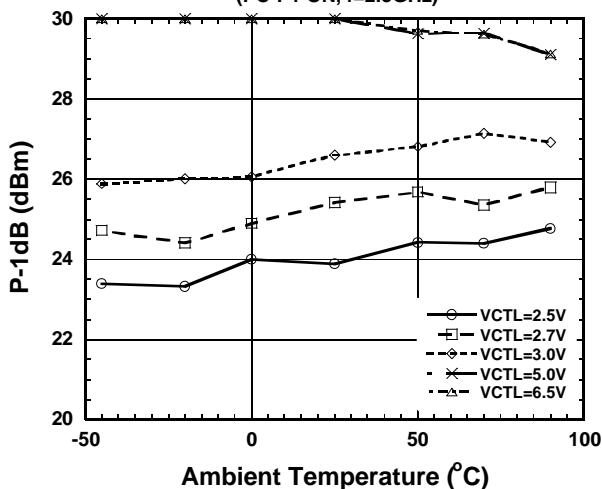

### ICTL vs. Ambient Temperature

(PC-P1 ON, f=2.5GHz, Pin=18dBm)

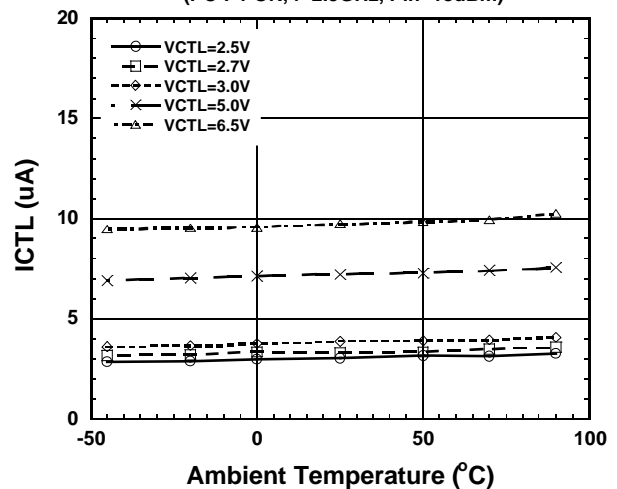

# NJG1600KB2

## APPLICATION CIRCUIT

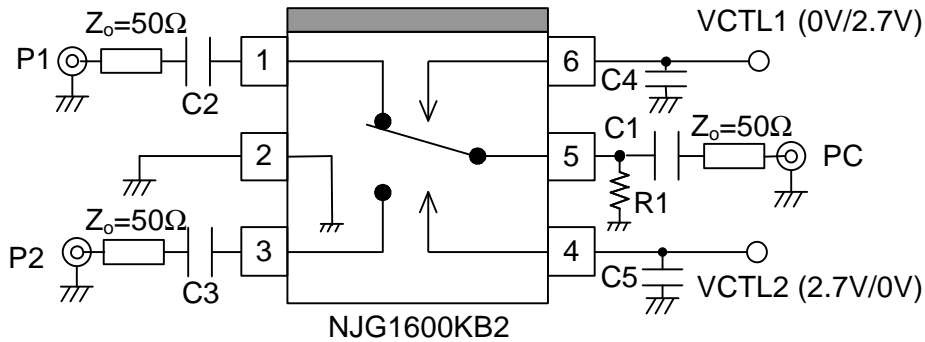

## RECOMMENDED PCB DESIGN

(TOP VIEW)

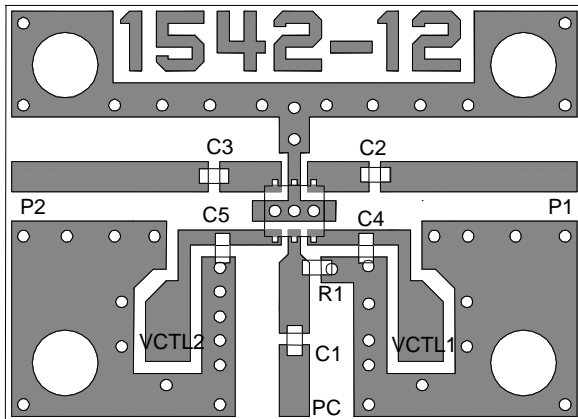

PCB SIZE=19.4x14.0mm

PCB:FR4,t=0.5mm

STRIPLINE WIDTH=1.0mm

CAPACITOR: size 1005

## PARTS LIST

No.	Parts list 1	Parts list 2
	f=0.1~0.5GHz	f=0.5~2.0GHz
C1~C3	1000pF	56pF
C4,C5	1000pF	1000pF

## PRECAUTIONS

- [1] The DC blocking capacitors have to be placed at RF terminal of P1, P2 and PC.
- [2] To reduce stripline influence on RF characteristics, please locate bypass capacitors (C4, C5) close to each terminals.
- [3] To avoid degradation of isolation or high power characteristics, please layout ground pattern right under this IC.

## ■PACKAGE OUTLINE (FLP6-B2)

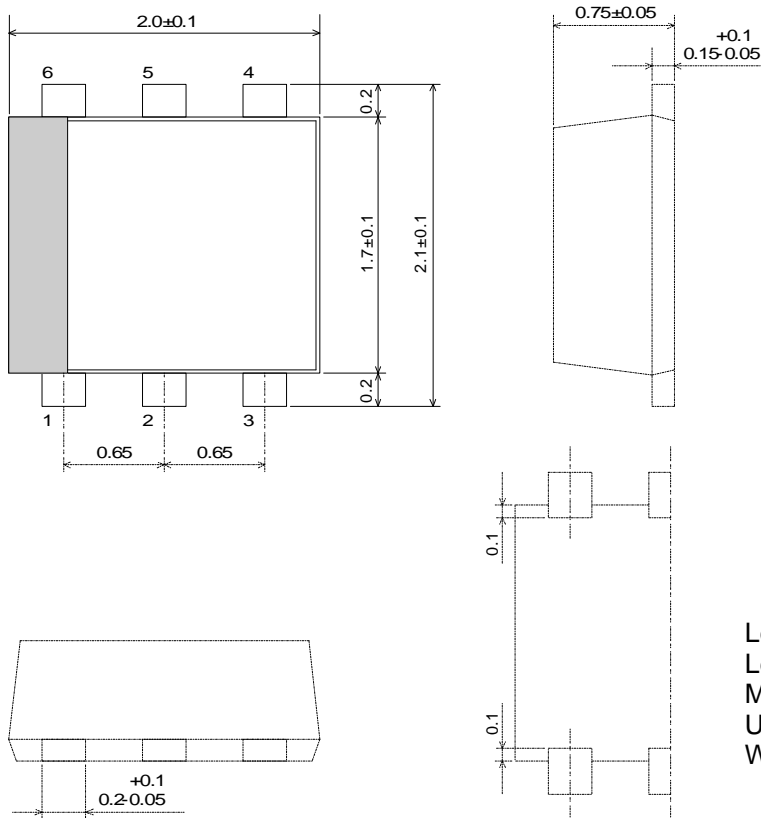

Lead material : Copper  
 Lead surface finish: Solder plating  
 Molding material : Epoxy resin  
 UNIT : mm  
 Weight : 6.5mg

### Cautions on using this product

This product contains Gallium-Arsenide (GaAs) which is a harmful material.

- Do NOT eat or put into mouth.
- Do NOT dispose in fire or break up this product.
- Do NOT chemically make gas or powder with this product.
- To waste this product, please obey the relating law of your country.

### [CAUTION]

The specifications on this databook are only given for information, without any guarantee as regards either mistakes or omissions. The application circuits in this databook are described only to show representative usages of the product and not intended for the guarantee or permission of any right including the industrial rights.

This product may be damaged with electric static discharge (ESD) or spike voltage. Please handle with care to avoid these damages.