

DATA SHEET

74AVCM162834

18-bit registered driver
with inverted register enable with 15 Ω
termination resistors (3-State)

Product specification

1999 Sep 14

18-bit registered driver with inverted register enable with 15 Ω termination resistors (3-State) 74AVCM162834

FEATURES

- Wide supply voltage range of 1.2 V to 3.6 V
- Complies with JEDEC standard no. 8-1A/5/7.
- CMOS low power consumption
- Input/output tolerant up to 3.6 V
- Low inductance multiple V_{CC} and GND pins for minimum noise and ground bounce

DESCRIPTION

The 74AVCM162834 is an 18-bit universal bus driver. Data flow is controlled by output enable (\overline{OE}), latch enable (\overline{LE}) and clock inputs (CP).

This product is designed to have an extremely fast propagation delay and a minimum amount of power consumption.

To ensure the high-impedance state during power up or power down, \overline{OE} should be tied to V_{CC} through a pullup resistor (Live Insertion).

PIN CONFIGURATION

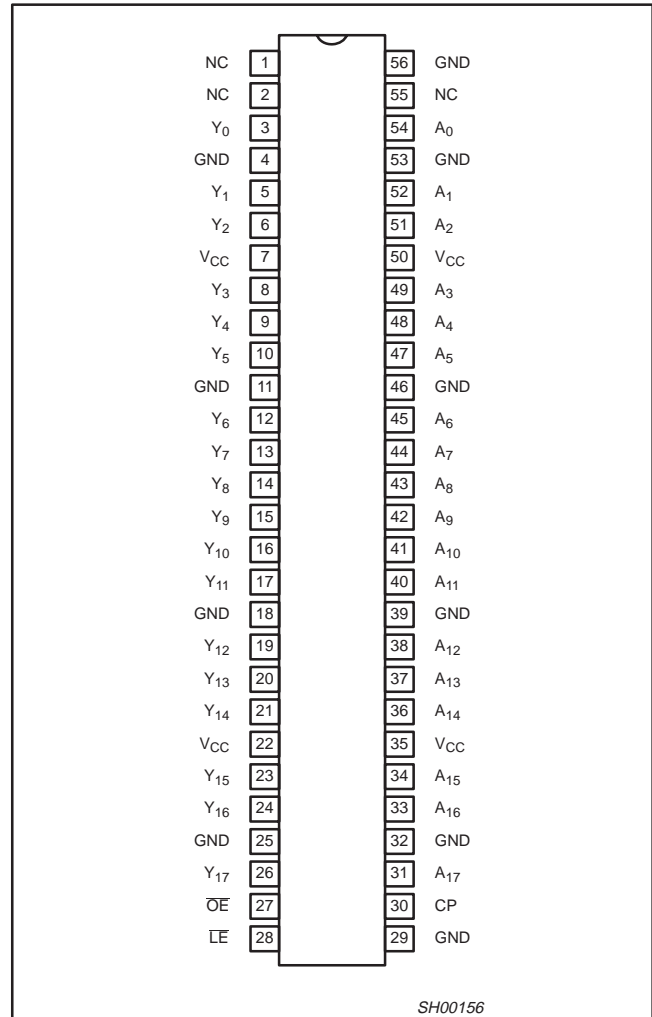

QUICK REFERENCE DATA

GND = 0 V; $T_{amb} = 25^{\circ}\text{C}$; $t_r = t_f \leq 2.0$ ns; $C_L = 30$ pF.

SYMBOL	PARAMETER	CONDITIONS	TYPICAL	UNIT	
t_{PHL}/t_{PLH}	Propagation delay An to Yn	$V_{CC} = 1.8$ V $V_{CC} = 2.5$ V $V_{CC} = 3.3$ V	2.6 2.0 1.7	ns	
t_{PHL}/t_{PLH}	Propagation delay LE to Yn; CP to Yn	$V_{CC} = 1.8$ V $V_{CC} = 2.5$ V $V_{CC} = 3.3$ V	2.9 2.3 1.9	ns	
C_I	Input capacitance		5.0	pF	
C_{PD}	Power dissipation capacitance per buffer	$V_I = \text{GND to } V_{CC}^1$	Outputs enabled Output disabled	25 6	pF

NOTES:

- C_{PD} is used to determine the dynamic power dissipation (P_D in μW):
 $P_D = C_{PD} \times V_{CC}^2 \times f_i + \Sigma (C_L \times V_{CC}^2 \times f_o)$ where: f_i = input frequency in MHz; C_L = output load capacitance in pF;
 f_o = output frequency in MHz; V_{CC} = supply voltage in V; $\Sigma (C_L \times V_{CC}^2 \times f_o)$ = sum of outputs.

ORDERING INFORMATION

PACKAGES	TEMPERATURE RANGE	ORDER CODE	DRAWING NUMBER
56-Pin Plastic Thin Shrink Small Outline (TSSOP) Type II	-40°C to $+85^{\circ}\text{C}$	74AVCM162834 DGG	SOT364-1

18-bit registered driver with inverted register enable with 15 Ω termination resistors (3-State)

74AVCM162834

PIN DESCRIPTION

PIN NUMBER	SYMBOL	NAME AND FUNCTION
1, 2, 55	NC	No connection
3, 5, 6, 8, 9, 10, 12, 13, 14, 15, 16, 17, 19, 20, 21, 23, 24, 26	Y ₀ to Y ₁₇	Data outputs
4, 11, 18, 25, 32, 39, 46, 53, 56	GND	Ground (0 V)
7, 22, 35, 50	V _{CC}	Positive supply voltage
27	\overline{OE}	Output enable input (active LOW)
28	\overline{LE}	Latch enable input (active LOW)
30	CP	Clock input
54, 52, 51, 49, 48, 47, 45, 44, 43, 42, 41, 40, 38, 37, 36, 34, 33, 31	A ₀ to A ₁₇	Data inputs

LOGIC SYMBOL

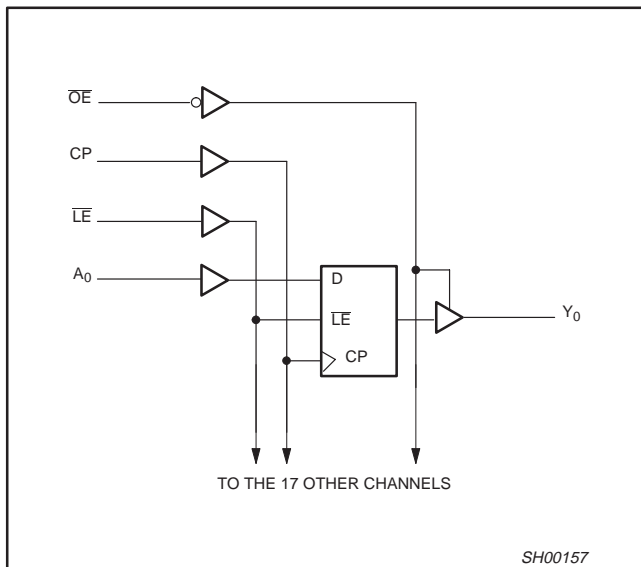

LOGIC SYMBOL (IEEE/IEC)

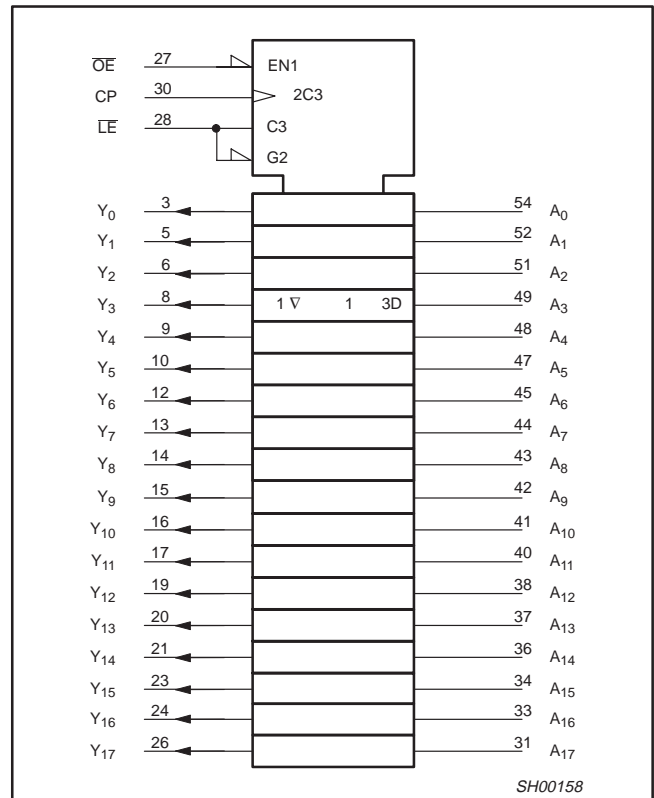

FUNCTION TABLE

INPUTS				OUTPUTS
\overline{OE}	\overline{LE}	CP	A	
H	X	X	X	Z
L	L	X	L	L
L	L	X	H	H
L	H	↑	L	L
L	H	↑	H	H
L	H	H	X	Y ₀ ¹
L	H	L	X	Y ₀ ²

- H = HIGH voltage level
- L = LOW voltage level
- X = Don't care
- Z = High impedance "off" state
- ↑ = LOW-to-HIGH level transition

NOTES:

- Output level before the indicated steady-state input conditions were established, provided that CP is high before LE goes low.
- Output level before the indicated steady-state input conditions were established.

18-bit registered driver with inverted register enable with 15 Ω termination resistors (3-State)

74AVCM162834

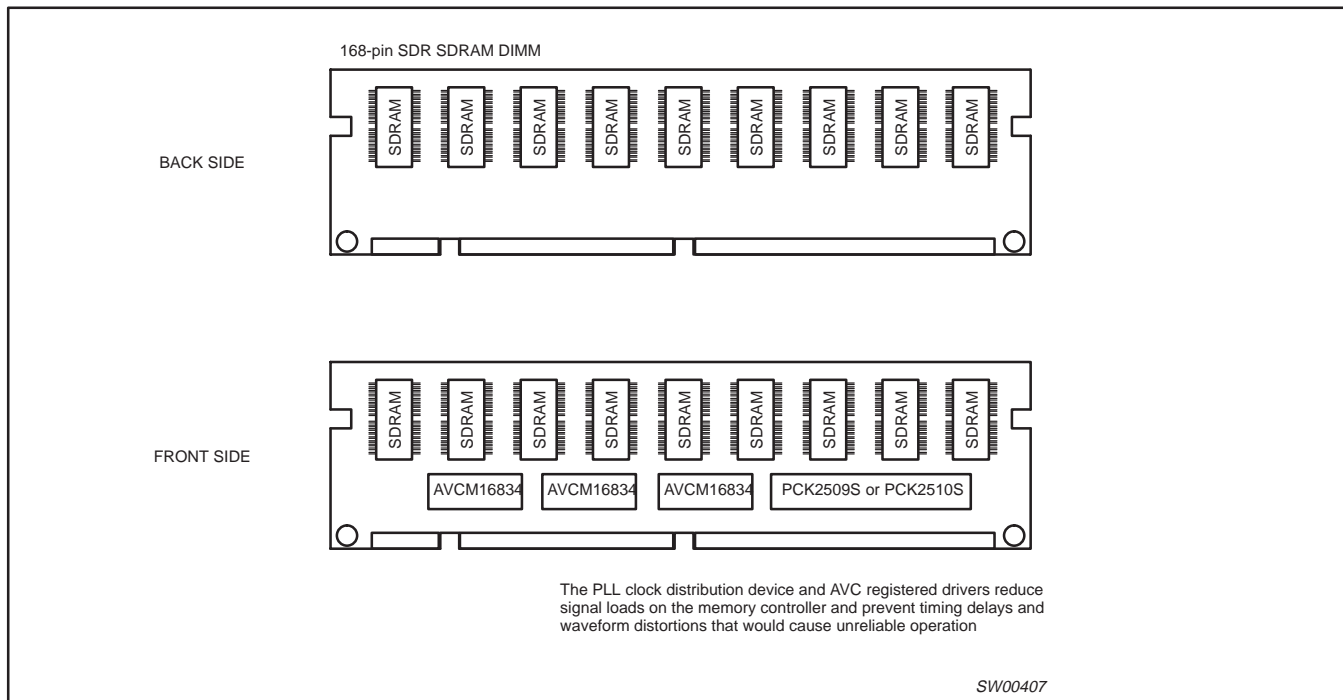

RECOMMENDED OPERATING CONDITIONS

SYMBOL	PARAMETER	CONDITIONS	MIN	MAX	UNIT
V _{CC}	DC supply voltage (according to JEDEC Low Voltage Standards)		1.65 2.3 3.0	1.95 2.7 3.6	V
	DC supply voltage (for low voltage applications)		1.2	3.6	
V _I	DC Input voltage range		0	3.6	V
V _O	DC output voltage range; output 3-State		0	3.6	V
	DC output voltage range; output HIGH or LOW state		0	V _{CC}	
T _{amb}	Operating free-air temperature range		-40	+85	°C
t _r , t _f	Input rise and fall times	V _{CC} = 1.65 to 2.3 V V _{CC} = 2.3 to 3.0 V V _{CC} = 3.0 to 3.6 V	0 0 0	30 20 10	ns/V

18-bit registered driver with inverted register enable with 15 Ω termination resistors (3-State)

74AVCM162834

ABSOLUTE MAXIMUM RATINGS

In accordance with the Absolute Maximum Rating System (IEC 134)

Voltages are referenced to GND (ground = 0V)

SYMBOL	PARAMETER	CONDITIONS	RATING	UNIT
V_{CC}	DC supply voltage		-0.5 to +4.6	V
I_{IK}	DC input diode current	$V_I < 0$	-50	mA
V_I	DC input voltage	For all inputs ¹	-0.5 to 4.6	V
I_{OK}	DC output diode current	$V_O > V_{CC}$ or $V_O < 0$	± 50	mA
V_O	DC output voltage; output 3-State	Note 1	-0.5 to 4.6	V
V_O	DC output voltage; output HIGH or LOW state	Note 1	-0.5 to $V_{CC} + 0.5$	V
I_O	DC output source or sink current	$V_O = 0$ to V_{CC}	± 50	mA
I_{GND}, I_{CC}	DC V_{CC} or GND current		± 100	mA
T_{stg}	Storage temperature range		-65 to +150	$^{\circ}C$
P_{TOT}	Power dissipation per package -plastic thin-medium-shrink (TSSOP)	For temperature range: -40 to +125 $^{\circ}C$ above +55 $^{\circ}C$ derate linearly with 8 mW/K	600	mW

NOTE:

1. The input and output voltage ratings may be exceeded if the input and output current ratings are observed.

DC ELECTRICAL CHARACTERISTICS

Over recommended operating conditions. Voltage are referenced to GND (ground = 0 V).

SYMBOL	PARAMETER	TEST CONDITIONS	LIMITS			UNIT
			Temp = -40 $^{\circ}C$ to +85 $^{\circ}C$			
			MIN	TYP ¹	MAX	
V_{IH}	HIGH level Input voltage	$V_{CC} = 1.2$ V	V_{CC}	-	-	V
		$V_{CC} = 1.65$ to 1.95 V	$0.65V_{CC}$	0.9	-	
		$V_{CC} = 2.3$ to 2.7 V	1.7	1.2	-	
		$V_{CC} = 3.0$ to 3.6 V	2.0	1.5	-	
V_{IL}	LOW level Input voltage	$V_{CC} = 1.2$ V	-	-	GND	V
		$V_{CC} = 1.65$ to 1.95 V	-	0.9	$0.35V_{CC}$	
		$V_{CC} = 2.3$ to 2.7 V	-	1.2	0.7	
		$V_{CC} = 3.0$ to 3.6 V	-	1.5	0.8	
V_{OH}	HIGH level output voltage	$V_{CC} = 1.65$ to 3.6 V; $V_I = V_{IH}$ or V_{IL} ; $I_O = -100$ μA	$V_{CC} - 0.20$	V_{CC}	-	V
		$V_{CC} = 1.65$ V; $V_I = V_{IH}$ or V_{IL} ; $I_O = -4$ mA	$V_{CC} - 0.45$	$V_{CC} - 0.10$	-	
		$V_{CC} = 2.3$ V; $V_I = V_{IH}$ or V_{IL} ; $I_O = -8$ mA	$V_{CC} - 0.55$	$V_{CC} - 0.28$	-	
		$V_{CC} = 3.0$ V; $V_I = V_{IH}$ or V_{IL} ; $I_O = -12$ mA	$V_{CC} - 0.70$	$V_{CC} - 0.32$	-	
V_{OL}	LOW level output voltage	$V_{CC} = 1.65$ to 3.6 V; $V_I = V_{IH}$ or V_{IL} ; $I_O = 100$ μA	-	GND	0.20	V
		$V_{CC} = 1.65$ V; $V_I = V_{IH}$ or V_{IL} ; $I_O = 4$ mA	-	0.10	0.45	
		$V_{CC} = 2.3$ V; $V_I = V_{IH}$ or V_{IL} ; $I_O = 8$ mA	-	0.26	0.55	
		$V_{CC} = 3.0$ V; $V_I = V_{IH}$ or V_{IL} ; $I_O = 12$ mA	-	0.36	0.70	
I_I	Input leakage current	$V_{CC} = 1.65$ to 3.6 V; $V_I = V_{CC}$ or GND	-	0.1	2.5	μA
I_{OFF}	3-State output OFF-state current	$V_{CC} = 0$ V; V_I or $V_O = 3.6$ V	-	0.1	± 10	μA
I_{IHZ}/I_{ILZ}	3-State output OFF-state current	$V_{CC} = 1.65$ to 3.6 V; $V_I = V_{CC}$ or GND	-	0.1	12.5	μA
I_{OZ}	3-State output OFF-state current	$V_{CC} = 1.65$ to 2.7 V; $V_I = V_{IH}$ or V_{IL} ; $V_O = V_{CC}$ or GND	-	0.1	5	μA
		$V_{CC} = 3.0$ to 3.6 V; $V_I = V_{IH}$ or V_{IL} ; $V_O = V_{CC}$ or GND	-	0.1	10	
I_{CC}	Quiescent supply current	$V_{CC} = 1.65$ to 2.7 V; $V_I = V_{CC}$ or GND; $I_O = 0$	-	0.1	20	μA
		$V_{CC} = 3.0$ to 3.6 V; $V_I = V_{CC}$ or GND; $I_O = 0$	-	0.2	40	

NOTES:

1. All typical values are at $T_{amb} = 25^{\circ}C$.

18-bit registered driver with inverted register enable with 15 Ω termination resistors (3-State)

74AVCM162834

AC CHARACTERISTICS

GND = 0 V; $t_r = t_f \leq 2.0$ ns; $C_L = 30$ pF

SYMBOL	PARAMETER	WAVE-FORM	LIMITS											UNIT
			$V_{CC} = 3.3 \pm 0.3$ V			$V_{CC} = 2.5 \pm 0.2$ V			$V_{CC} = 1.8 \pm 0.15$ V			$V_{CC} = 1.2$ V		
			MIN	TYP ¹	MAX	MIN	TYP ¹	MAX	MIN	TYP ¹	MAX	MIN	TYP	
t_{PHL}/t_{PLH}	Propagation delay An to Yn	1, 7	0.7	1.7	2.5	0.8	2.0	3.1	1.0	2.6	4.5	–	5.2	ns
	Propagation delay \overline{LE} to Yn	2, 7	0.7	1.9	2.7	0.8	2.3	3.3	1.0	2.9	5.0	–	5.6	
	Propagation delay CP to Yn	3, 7	0.7	1.7	2.5	0.8	2.0	3.0	1.0	2.6	4.5	–	5.2	
t_{PZH}/t_{PZL}	3-State output enable time \overline{OE} to Yn	6, 7	1.0	2.3	4.5	1.0	2.5	4.5	1.5	3.0	6.5	–	5.5	ns
t_{PHZ}/t_{PLZ}	3-State output disable time \overline{OE} to Yn	6, 7	1.0	2.3	3.5	1.0	2.2	4.0	1.5	3.5	6.5	–	6.9	ns
t_w	CP pulse width HIGH or LOW	3, 7	1.0	–	–	1.2	–	–	2.0	–	–	–	–	ns
	\overline{LE} pulse width HIGH	2, 7	1.0	–	–	1.2	–	–	2.0	–	–	–	–	
t_{SU}	Set-up time An to CP	5, 7	0.7	–	–	0.7	–	–	0.7	–	–	1.0	–	ns
	Set-up time An to \overline{LE} HIGH	4, 7	0.5	–	–	0.5	–	–	0.5	–	–	0.2	–	
	Set-up time An to \overline{LE} LOW	4, 7	0.5	–	–	0.5	–	–	0.6	–	–	2.0	–	
t_h	Hold time An to CP	5, 7	0.9	–	–	0.9	–	–	1.0	–	–	1.5	–	ns
	Hold time An to \overline{LE} HIGH	4, 7	1.6	–	–	1.7	–	–	2.0	–	–	3.2	–	
	Hold time An to \overline{LE} LOW	4, 7	1.4	–	–	1.5	–	–	1.7	–	–	2.8	–	
F_{max}	Maximum clock pulse frequency	3, 7	500	–	–	400	–	–	250	–	–	–	–	MHz

NOTES:

1. All typical values are measured at $T_{amb} = 25^\circ\text{C}$ and at $V_{CC} = 1.8$ V, 2.5 V, 3.3 V.

18-bit registered driver with inverted register enable with 15 Ω termination resistors (3-State)

74AVCM162834

AC WAVEFORMS FOR $V_{CC} = 3.0\text{ V TO } 3.6\text{ V RANGE}$

$V_M = 0.5 V_{CC}$
 $V_X = V_{OL} + 0.300\text{ V}$
 $V_Y = V_{OH} - 0.300\text{ V}$
 V_{OL} and V_{OH} are the typical output voltage drop that occur with the output load.
 $V_I = V_{CC}$

AC WAVEFORMS FOR $V_{CC} = 2.3\text{ V TO } 2.7\text{ V AND } V_{CC} < 2.3\text{ V RANGE}$

$V_M = 0.5 V_{CC}$
 $V_X = V_{OL} + 0.15\text{ V}$
 $V_Y = V_{OH} - 0.15\text{ V}$
 V_{OL} and V_{OH} are the typical output voltage drop that occur with the output load.
 $V_I = V_{CC}$

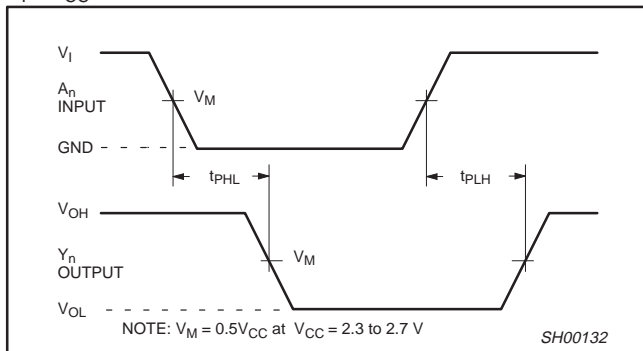

Waveform 1. Input (An) to output (Yn) propagation delay

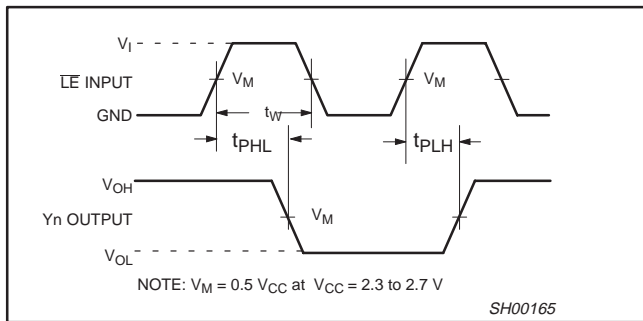

Waveform 2. Latch enable input (LE) pulse width, the latch enable input to output (Yn) propagation delays.

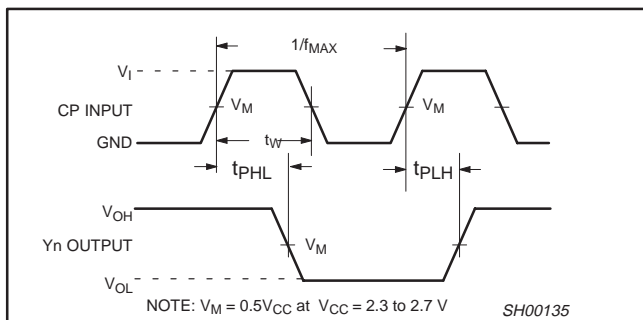

Waveform 3. The clock (CP) to Yn propagation delays, the clock pulse width and the maximum clock frequency.

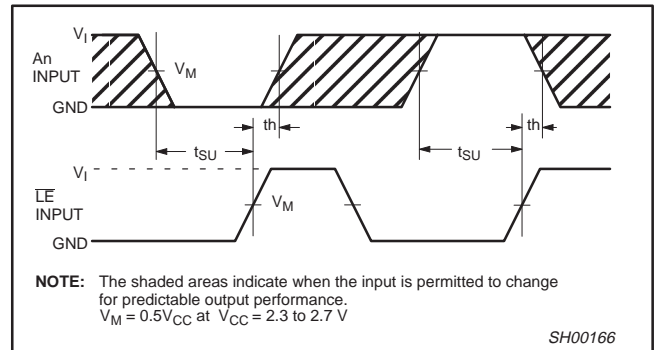

Waveform 4. Data set-up and hold times for the An input to the LE input

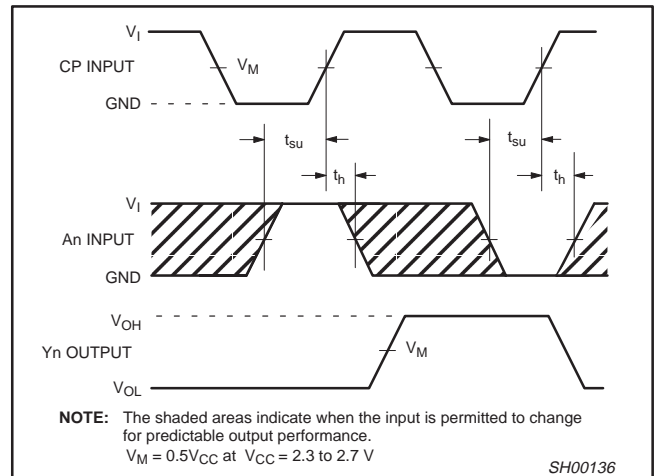

Waveform 5. Data set-up and hold times for the An input to the clock CP input

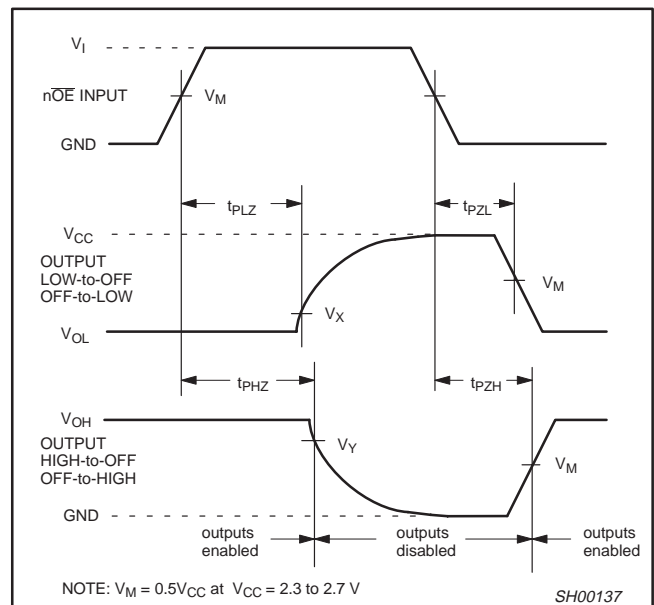

Waveform 6. 3-State enable and disable times

18-bit registered driver with inverted register enable with 15 Ω termination resistors (3-State)

74AVCM162834

TEST CIRCUIT

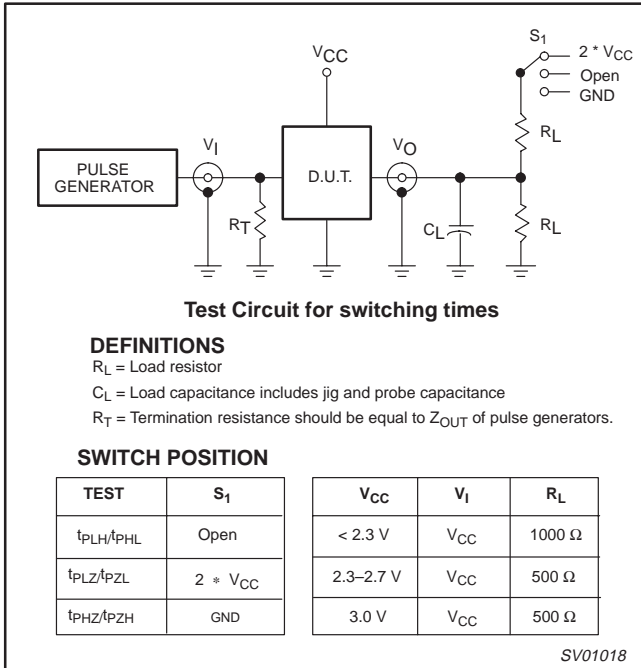

Waveform 7. Load circuitry for switching times

GRAPHS

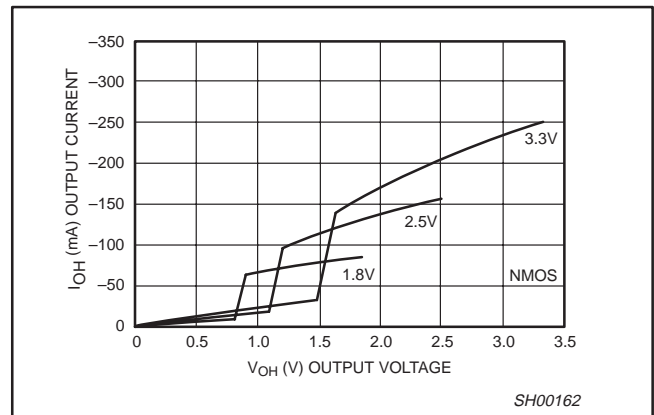
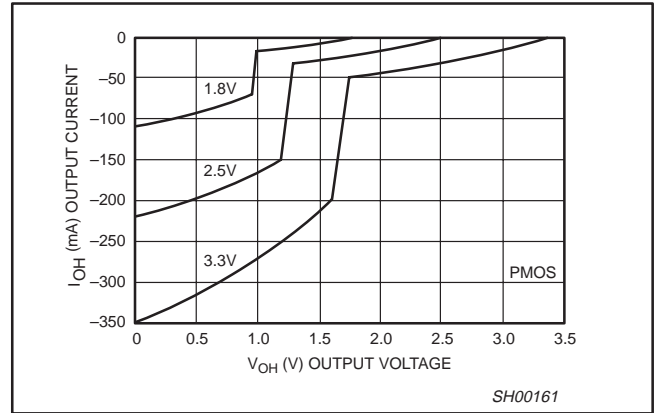

18-bit registered driver with inverted register enable with
15 Ω termination resistors (3-State)

74AVCM162834

TSSOP56: plastic thin shrink small outline package; 56 leads; body width 6.1mm

SOT364-1

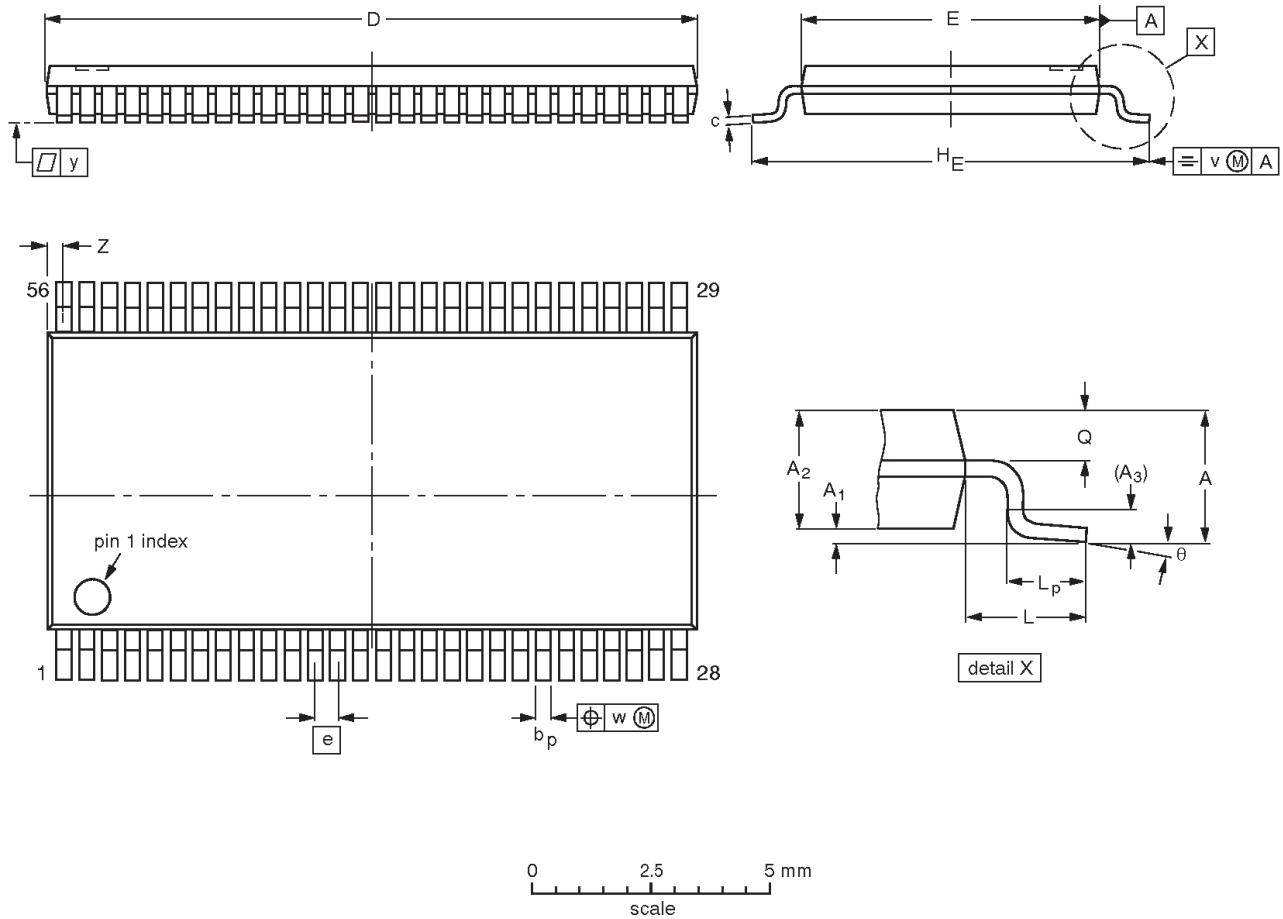

DIMENSIONS (mm are the original dimensions).

UNIT	A max.	A ₁	A ₂	A ₃	b _p	c	D ⁽¹⁾	E ⁽²⁾	e	H _E	L	L _p	Q	v	w	y	Z	θ
mm	1.2	0.15 0.05	1.05 0.85	0.25	0.28 0.17	0.2 0.1	14.1 13.9	6.2 6.0	0.5	8.3 7.9	1.0	0.8 0.4	0.50 0.35	0.25	0.08	0.1	0.5 0.1	8° 0°

Notes

1. Plastic or metal protrusions of 0.15 mm maximum per side are not included.
2. Plastic interlead protrusions of 0.25 mm maximum per side are not included.

OUTLINE VERSION	REFERENCES				EUROPEAN PROJECTION	ISSUE DATE
	IEC	JEDEC	EIAJ			
SOT364-1		MO-153EE				93-02-03 95-02-10

18-bit registered driver with inverted register enable with 15 Ω termination resistors (3-State)

74AVCM162834

Data sheet status

Data sheet status	Product status	Definition [1]
Objective specification	Development	This data sheet contains the design target or goal specifications for product development. Specification may change in any manner without notice.
Preliminary specification	Qualification	This data sheet contains preliminary data, and supplementary data will be published at a later date. Philips Semiconductors reserves the right to make changes at any time without notice in order to improve design and supply the best possible product.
Product specification	Production	This data sheet contains final specifications. Philips Semiconductors reserves the right to make changes at any time without notice in order to improve design and supply the best possible product.

[1] Please consult the most recently issued datasheet before initiating or completing a design.

Definitions

Short-form specification — The data in a short-form specification is extracted from a full data sheet with the same type number and title. For detailed information see the relevant data sheet or data handbook.

Limiting values definition — Limiting values given are in accordance with the Absolute Maximum Rating System (IEC 134). Stress above one or more of the limiting values may cause permanent damage to the device. These are stress ratings only and operation of the device at these or at any other conditions above those given in the Characteristics sections of the specification is not implied. Exposure to limiting values for extended periods may affect device reliability.

Application information — Applications that are described herein for any of these products are for illustrative purposes only. Philips Semiconductors make no representation or warranty that such applications will be suitable for the specified use without further testing or modification.

Disclaimers

Life support — These products are not designed for use in life support appliances, devices or systems where malfunction of these products can reasonably be expected to result in personal injury. Philips Semiconductors customers using or selling these products for use in such applications do so at their own risk and agree to fully indemnify Philips Semiconductors for any damages resulting from such application.

Right to make changes — Philips Semiconductors reserves the right to make changes, without notice, in the products, including circuits, standard cells, and/or software, described or contained herein in order to improve design and/or performance. Philips Semiconductors assumes no responsibility or liability for the use of any of these products, conveys no license or title under any patent, copyright, or mask work right to these products, and makes no representations or warranties that these products are free from patent, copyright, or mask work right infringement, unless otherwise specified.

Philips Semiconductors
811 East Arques Avenue
P.O. Box 3409
Sunnyvale, California 94088-3409
Telephone 800-234-7381

© Copyright Philips Electronics North America Corporation 1999
All rights reserved. Printed in U.S.A.

print code

Date of release: 09-99

Document order number:

9397-750-06412

Let's make things better.

SUNSTAR 商斯达实业集团是集研发、生产、工程、销售、代理经销、技术咨询、信息服务等为一体的高科技企业，是专业高科技电子产品生产厂家，是具有 10 多年历史的专业电子元器件供应商，是中国最早和最大的仓储式连锁规模经营大型综合电子零部件代理分销商之一，是一家专业代理和分销世界各大品牌 IC 芯片和电子元器件的连锁经营综合性国际公司，专业经营进口、国产名厂名牌电子元件，型号、种类齐全。在香港、北京、深圳、上海、西安、成都等全国主要电子市场设有直属分公司和产品展示展销窗口门市部专卖店及代理分销商，已在全国范围内建成强大统一的供货和代理分销网络。我们专业代理经销、开发生产电子元器件、集成电路、传感器、微波光电元器件、工控机/DOC/DOM 电子盘、专用电路、单片机开发、MCU/DSP/ARM/FPGA 软件硬件、二极管、三极管、模块等，是您可靠的一站式现货配套供应商、方案提供商、部件功能模块开发配套商。商斯达实业公司拥有庞大的资料库，有数位毕业于著名高校——有中国电子工业摇篮之称的西安电子科技大学（西军电）并长期从事国防尖端科技研究的高级工程师为您精挑细选、量身订做各种高科技电子元器件，并解决各种技术问题。

微波光电部专业代理经销高频、微波、光纤、光电元器件、组件、部件、模块、整机；电磁兼容元器件、材料、设备；微波 CAD、EDA 软件、开发测试仿真工具；微波、光纤仪器仪表。欢迎国外高科技微波、光纤厂商将优秀产品介绍到中国、共同开拓市场。长期大量现货专业批发高频、微波、卫星、光纤、电视、CATV 器件：晶振、VCO、连接器、PIN 开关、变容二极管、开关二极管、低噪晶体管、功率电阻及电容、放大器、功率管、MMIC、混频器、耦合器、功分器、振荡器、合成器、衰减器、滤波器、隔离器、环行器、移相器、调制解调器；光电子元件和组件：红外发射管、红外接收管、光电开关、光敏管、发光二极管和发光二极管组件、半导体激光二极管和激光器组件、光电探测器和光接收组件、光发射接收模块、光纤激光器和光放大器、光调制器、光开关、DWDM 用光发射和接收器件、用户接入系统光收发器件与模块、光纤连接器、光纤跳线/尾纤、光衰减器、光纤适配器、光隔离器、光耦合器、光环行器、光复用器/转换器；无线收发芯片和模组、蓝牙芯片和模组。

更多产品请看本公司产品专用销售网站：

商斯达中国传感器科技信息网：<http://www.sensor-ic.com/>

商斯达工控安防网：<http://www.pc-ps.net/>

商斯达电子元器件网：<http://www.sunstare.com/>

商斯达微波光电产品网：[HTTP://www.rfoe.net/](http://www.rfoe.net/)

商斯达消费电子产品网：<http://www.icasic.com/>

商斯达实业科技产品网：<http://www.sunstars.cn/> 微波元器件销售热线：

地址：深圳市福田区福华路福庆街鸿图大厦 1602 室

电话：0755-82884100 83397033 83396822 83398585

传真：0755-83376182 (0) 13823648918 MSN: SUNS8888@hotmail.com

邮编：518033 E-mail:szss20@163.com QQ: 195847376

深圳赛格展销部：深圳华强北路赛格电子市场 2583 号 电话：0755-83665529 25059422

技术支持：0755-83394033 13501568376

欢迎索取免费详细资料、设计指南和光盘；产品凡多，未能尽录，欢迎来电查询。

北京分公司：北京海淀区知春路 132 号中发电子大厦 3097 号

TEL: 010-81159046 82615020 13501189838 FAX: 010-62543996

上海分公司：上海市北京东路 668 号上海赛格电子市场 D125 号

TEL: 021-28311762 56703037 13701955389 FAX: 021-56703037

西安分公司：西安高新开发区 20 所(中国电子科技集团导航技术研究所)

西安劳动南路 88 号电子商城二楼 D23 号

TEL: 029-81022619 13072977981 FAX:029-88789382

SUNSTAR 商斯达实业集团是集研发、生产、工程、销售、代理经销、技术咨询、信息服务等为一体的高科技企业，是专业高科技电子产品生产厂家，是具有 10 多年历史的专业电子元器件供应商，是中国最早和最大的仓储式连锁规模经营大型综合电子零部件代理分销商之一，是一家专业代理和分销世界各大品牌 IC 芯片和电子元器件的连锁经营综合性国际公司，专业经营进口、国产名厂名牌电子元件，型号、种类齐全。在香港、北京、深圳、上海、西安、成都等全国主要电子市场设有直属分公司和产品展示展销窗口门市部专卖店及代理分销商，已在全国范围内建成强大统一的供货和代理分销网络。我们专业代理经销、开发生产电子元器件、集成电路、传感器、微波光电元器件、工控机/DOC/DOM 电子盘、专用电路、单片机开发、MCU/DSP/ARM/FPGA 软件硬件、二极管、三极管、模块等，是您可靠的一站式现货配套供应商、方案提供商、部件功能模块开发配套商。商斯达实业公司拥有庞大的资料库，有数位毕业于著名高校——有中国电子工业摇篮之称的西安电子科技大学（西军电）并长期从事国防尖端科技研究的高级工程师为您精挑细选、量身订做各种高科技电子元器件，并解决各种技术问题。

微波光电部专业代理经销高频、微波、光纤、光电元器件、组件、部件、模块、整机；电磁兼容元器件、材料、设备；微波 CAD、EDA 软件、开发测试仿真工具；微波、光纤仪器仪表。欢迎国外高科技微波、光纤厂商将优秀产品介绍到中国、共同开拓市场。长期大量现货专业批发高频、微波、卫星、光纤、电视、CATV 器件：晶振、VCO、连接器、PIN 开关、变容二极管、开关二极管、低噪晶体管、功率电阻及电容、放大器、功率管、MMIC、混频器、耦合器、功分器、振荡器、合成器、衰减器、滤波器、隔离器、环行器、移相器、调制解调器；光电子元件和组件：红外发射管、红外接收管、光电开关、光敏管、发光二极管和发光二极管组件、半导体激光二极管和激光器组件、光电探测器和光接收组件、光发射接收模块、光纤激光器和光放大器、光调制器、光开关、DWDM 用光发射和接收器件、用户接入系统光收发器件与模块、光纤连接器、光纤跳线/尾纤、光衰减器、光纤适配器、光隔离器、光耦合器、光环行器、光复用器/转换器；无线收发芯片和模组、蓝牙芯片和模组。

更多产品请看本公司产品专用销售网站：

商斯达中国传感器科技信息网：<http://www.sensor-ic.com/>

商斯达工控安防网：<http://www.pc-ps.net/>

商斯达电子元器件网：<http://www.sunstare.com/>

商斯达微波光电产品网：[HTTP://www.rfoe.net/](http://www.rfoe.net/)

商斯达消费电子产品网：<http://www.icasic.com/>

商斯达实业科技产品网：<http://www.sunstars.cn/> 微波元器件销售热线：

地址：深圳市福田区福华路福庆街鸿图大厦 1602 室

电话：0755-82884100 83397033 83396822 83398585

传真：0755-83376182 (0) 13823648918 MSN: SUNS8888@hotmail.com

邮编：518033 E-mail:szss20@163.com QQ: 195847376

深圳赛格展销部：深圳华强北路赛格电子市场 2583 号 电话：0755-83665529 25059422

技术支持：0755-83394033 13501568376

欢迎索取免费详细资料、设计指南和光盘；产品凡多，未能尽录，欢迎来电查询。

北京分公司：北京海淀区知春路 132 号中发电子大厦 3097 号

TEL: 010-81159046 82615020 13501189838 FAX: 010-62543996

上海分公司：上海市北京东路 668 号上海赛格电子市场 D125 号

TEL: 021-28311762 56703037 13701955389 FAX: 021-56703037

西安分公司：西安高新开发区 20 所(中国电子科技集团导航技术研究所)

西安劳动南路 88 号电子商城二楼 D23 号

TEL: 029-81022619 13072977981 FAX:029-88789382