

DATA SHEET

SA631

1GHz low voltage LNA and mixer

Product specification

1998 Jan 08

IC17 Data Handbook

1GHz low voltage LNA and mixer

SA631

DESCRIPTION

The SA631 is a combined low-noise BiCMOS amplifier, and mixer designed for high-performance low-power communication systems from 800-1000MHz. The low-noise preamplifier has a 1.7dB noise figure at 881MHz with 15dB gain and an IP3 intercept of -7dBm at the input. The gain is stabilized by on-chip compensation to vary less than $\pm 0.2\text{dB}$ over -40 to $+85^\circ\text{C}$ temperature range. The wide-dynamic-range mixer has a 10dB noise figure and IP3 of $+3.3\text{dBm}$ at the input at 881MHz. The nominal current drawn from a single 3V supply is 8.3mA. Additionally, the entire circuit can be powered down to further reduce the supply current to less than $20\mu\text{A}$.

FEATURES

- Low current consumption
- Outstanding gain and noise figure
- Excellent gain stability versus temperature and supply voltage
- LNA and mixer power down capability
- Designed in Philips state of the art BiCMOS QUBIC process

APPLICATIONS

- 900MHz cellular and cordless front-end
- Spread spectrum receivers
- RF data links
- UHF frequency conversion
- Portable radio

ORDERING INFORMATION

DESCRIPTION	TEMPERATURE RANGE	ORDER CODE	DWG #
20-Pin Shrink Small Outline Package (Surface-mount, SSOP)	-40 to $+85^\circ\text{C}$	SA631DK	SOT266-1

BLOCK DIAGRAM

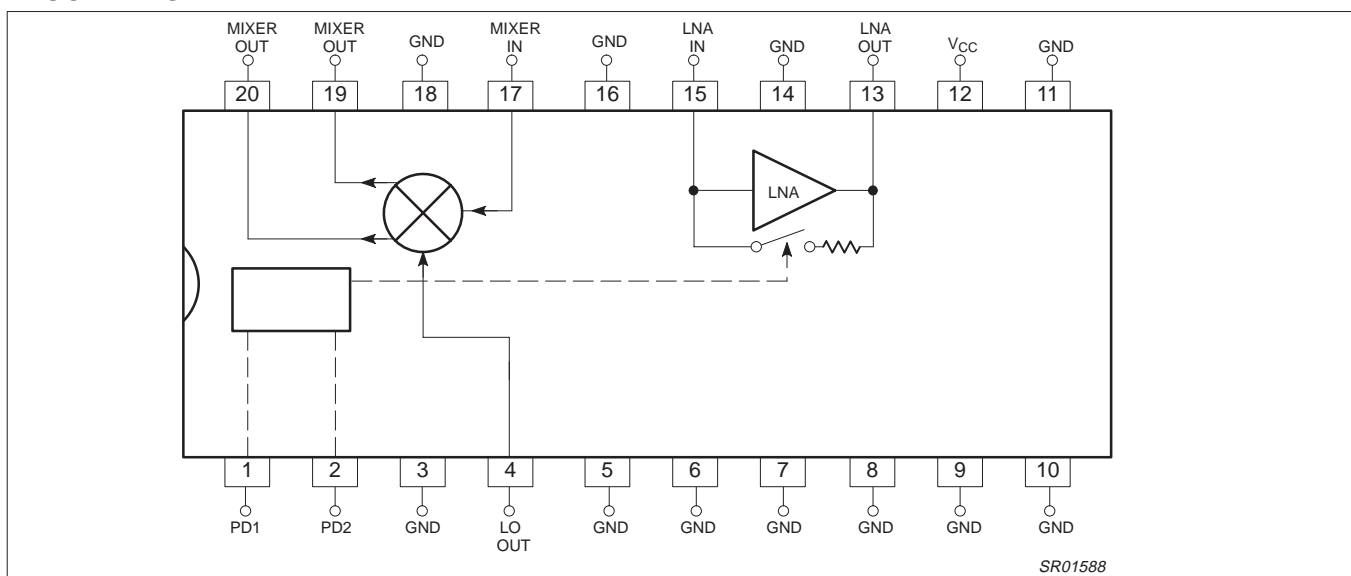

Figure 2. SA631 Block Diagram

PIN CONFIGURATION

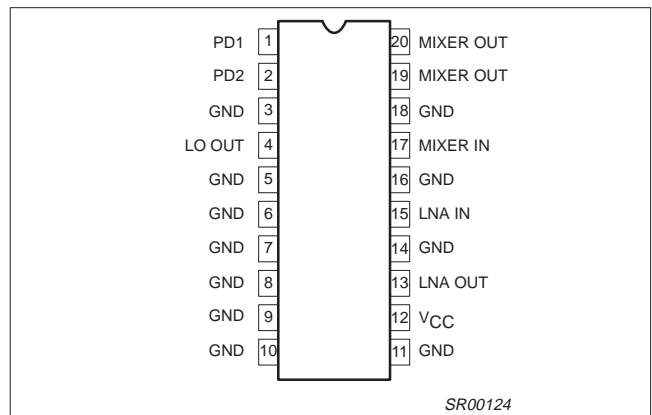

Figure 1. Pin Configuration

1GHz low voltage LNA and mixer

SA631

ABSOLUTE MAXIMUM RATINGS

SYMBOL	PARAMETER	RATING	UNITS
V_{CC}	Supply voltage ¹	-0.3 to +6	V
V_{IN}	Voltage applied to any other pin	-0.3 to ($V_{CC} + 0.3$)	V
P_D	Power dissipation, $T_{amb} = 25^\circ\text{C}$ (still air) ² 20-Pin Plastic SSOP	980	mW
T_{JMAX}	Maximum operating junction temperature	150	$^\circ\text{C}$
P_{MAX}	Maximum power input/output	+20	dBm
T_{STG}	Storage temperature range	-65 to +150	$^\circ\text{C}$

NOTES:

- Transients exceeding 8V on V_{CC} pin may damage product.
- Maximum dissipation is determined by the operating ambient temperature and the thermal resistance,
 θ_{JA} : 20-Pin SSOP = 110°C/W
- Pins 19 and 20 are ESD sensitive (mixer outputs).

RECOMMENDED OPERATING CONDITIONS

SYMBOL	PARAMETER	RATING	UNITS
V_{CC}	Supply voltage	2.7 to 5.5	V
T_{amb}	Operating ambient temperature range	-40 to +85	$^\circ\text{C}$
T_J	Operating junction temperature	-40 to +105	$^\circ\text{C}$

DC ELECTRICAL CHARACTERISTICS

 $V_{CC} = +3.0\text{V}$, $T_{amb} = 25^\circ\text{C}$; unless otherwise stated.

SYMBOL	PARAMETER	TEST CONDITIONS	LIMITS			UNITS
			MIN	TYP	MAX	
I_{CC}	Supply current	Full power-on		8.3		mA
		LNA powered-down		5.2		mA
		Full power-down		20		μA
V_T	PD logic threshold voltage		1.2	1.6	1.8	V
V_{IH}	Logic 1 level		2.0		V_{CC}	V
V_{IL}	Logic 0 level		-0.3		0.8	V
I_{IL}	PD1 input current	Enable = 0.4V		10		μA
I_{IH}	PD2 input current	Enable = 2.4V		10		μA

1GHz low voltage LNA and mixer

SA631

AC ELECTRICAL CHARACTERISTICS $V_{CC} = +3.0V$, $T_{amb} = 25^{\circ}C$; $RF_{IN} = 881MHz$, $f_{VCO} = 964MHz$; unless otherwise stated.

SYMBOL	PARAMETER	TEST CONDITIONS	LIMITS			UNITS
			-3 σ	TYP	+3 σ	
Low Noise Amplifier						
f_{RF}	RF input frequency range		800		1000	MHz
S_{21}	Amplifier gain			15		dB
S_{21}	Amplifier gain in power-down mode			-28		dB
$\Delta S_{21}/\Delta T$	Gain temperature sensitivity enabled			0.006		dB/ $^{\circ}C$
$\Delta S_{21}/\Delta f$	Gain frequency variation	800MHz - 1.0GHz		± 0.013		dB/MHz
S_{12}	Amplifier reverse isolation	@ 881 MHz		-28		dB
S_{11}	Amplifier input match	With ext. impedance matching		-10		dB
S_{22}	Amplifier output match			-10		dB
P_{-1dB}	Amplifier input 1dB gain compression			-20		dBm
IP3	Amplifier input third order intercept			-7		dBm
NF	Amplifier noise figure			1.7		dB
t_{ON}	Amplifier turn-on time (Enable Lo \rightarrow Hi)			120		μs
t_{OFF}	Amplifier turn-off time (Enable Hi \rightarrow Lo)			0.3		μs
Mixer						
PG_C	Mixer power conversion gain: $R_P = R_L = 1.2k\Omega$	$f_{RF} = 881MHz$, $f_{LO} = 964MHz$, $f_{IF} = 83MHz$		9.6		dB
S_{11M}	Mixer input match	Ext. impedance matching req.		-10		dB
NF_M	Mixer SSB noise figure			10		dB
P_{-1dB}	Mixer input 1dB gain compression			-14.5		dBm
IP3M	Mixer input third order intercept			3.3		dBm
IP2INT	Mixer input second order intercept			38		dBm
P_{RFM-IF}	Mixer RF feedthrough	$RF_{IN} = -32dBm$		-45		dBm
P_{LO-IF}	LO feedthrough to IF	$LO = -0dBm$		-23		dBm
P_{LO-RFM}	LO to mixer input feedthrough			-32		dBm
P_{LO-RF}	LO to LNA input feedthrough			-42		dBm
Overall System						
G_{SYS}	System gain	LNA + Mixer	23.9	24.6	25.3	dB

1GHz low voltage LNA and mixer

SA631

Table 1. Power ON/OFF Control Logic

PD1	PD2	
0	0	Full chip power-down
0	1 or open	Mixer on, LNA power-down
1 or open	0	Standby (bias on)
1 or open	1 or open	Full chip power-on (default)

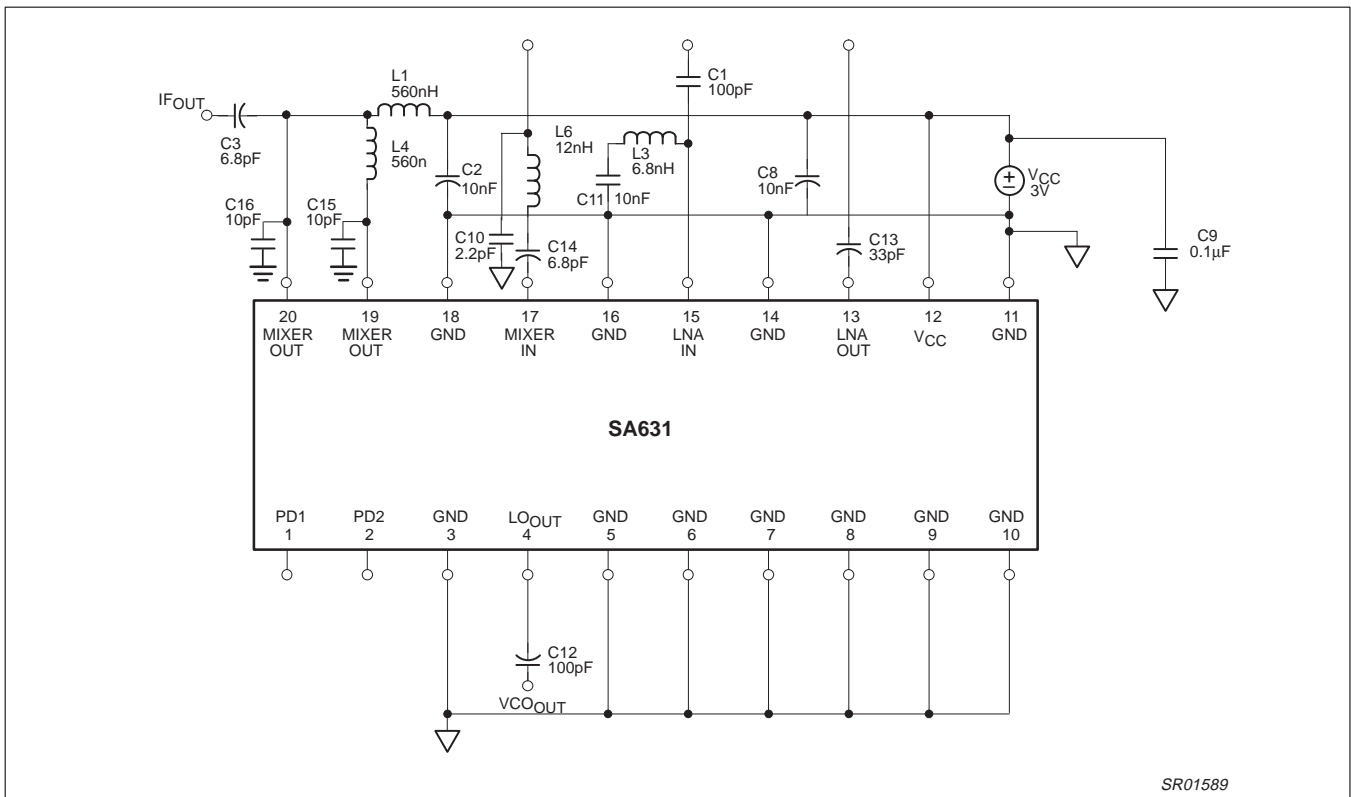

SR01589

Figure 3. SA631 Application Circuit

1GHz low voltage LNA and mixer

SA631

PERFORMANCE CHARACTERISTICS

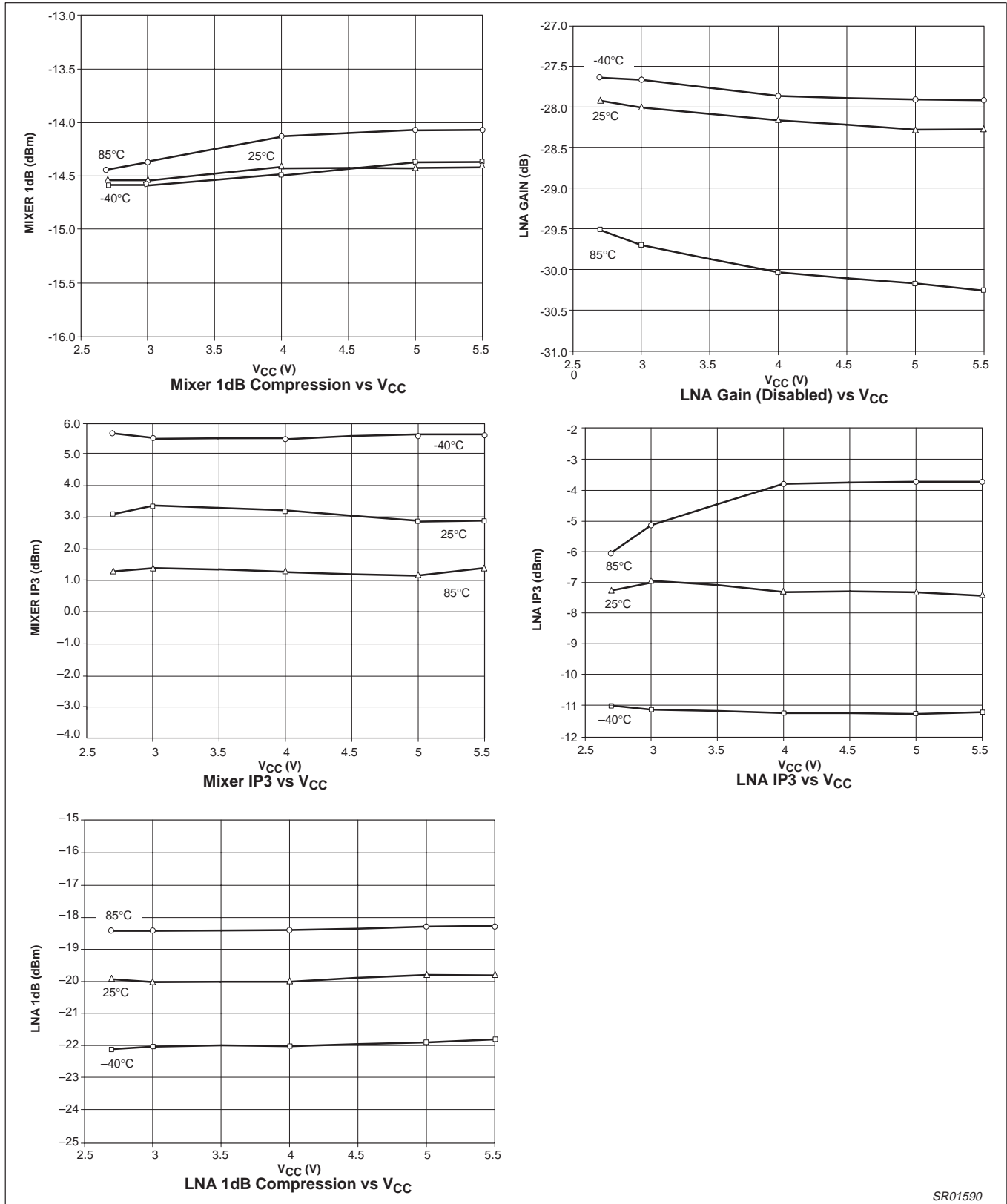

Figure 4.

SR01590

1GHz low voltage LNA and mixer

SA631

PERFORMANCE CHARACTERISTICS

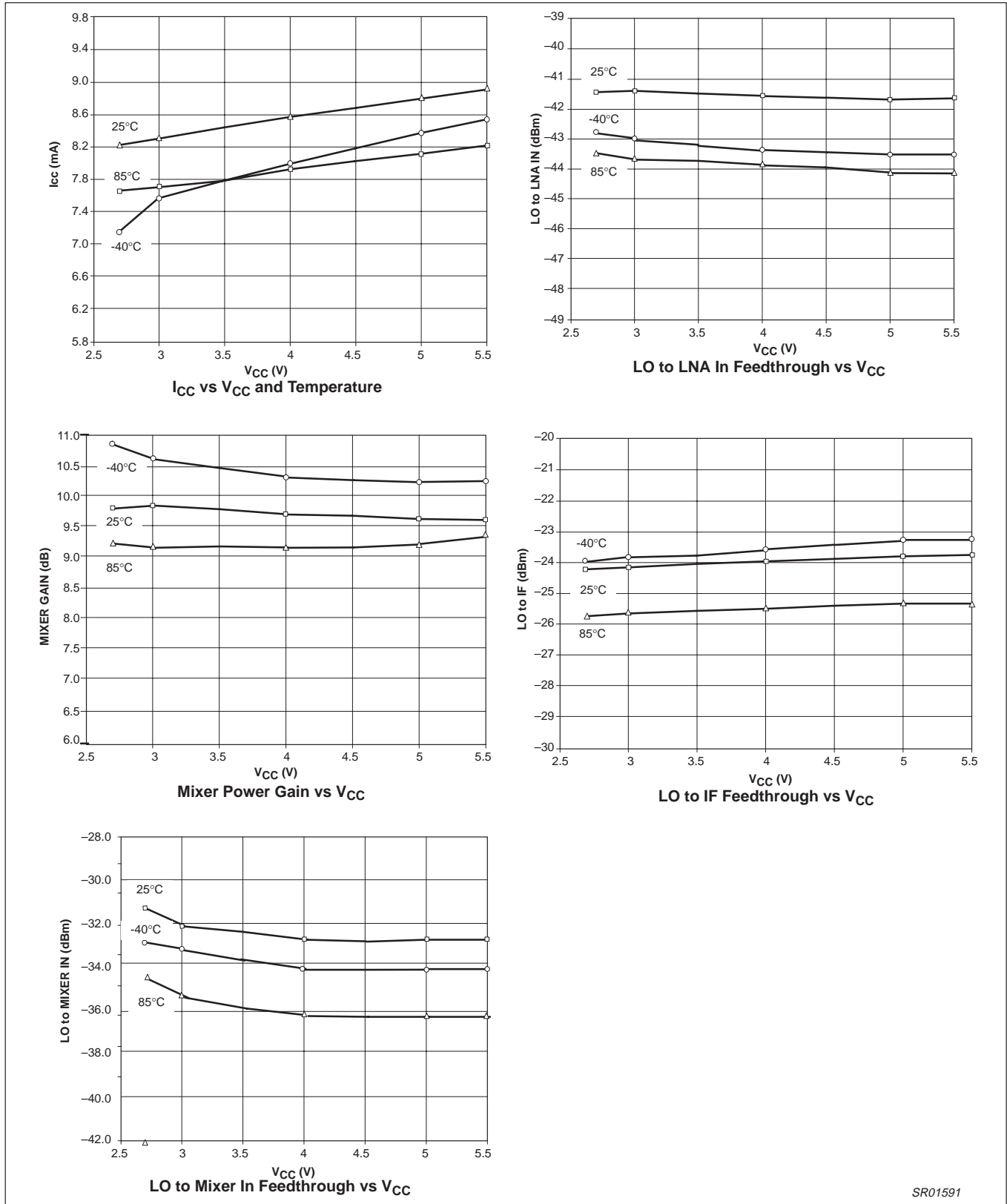
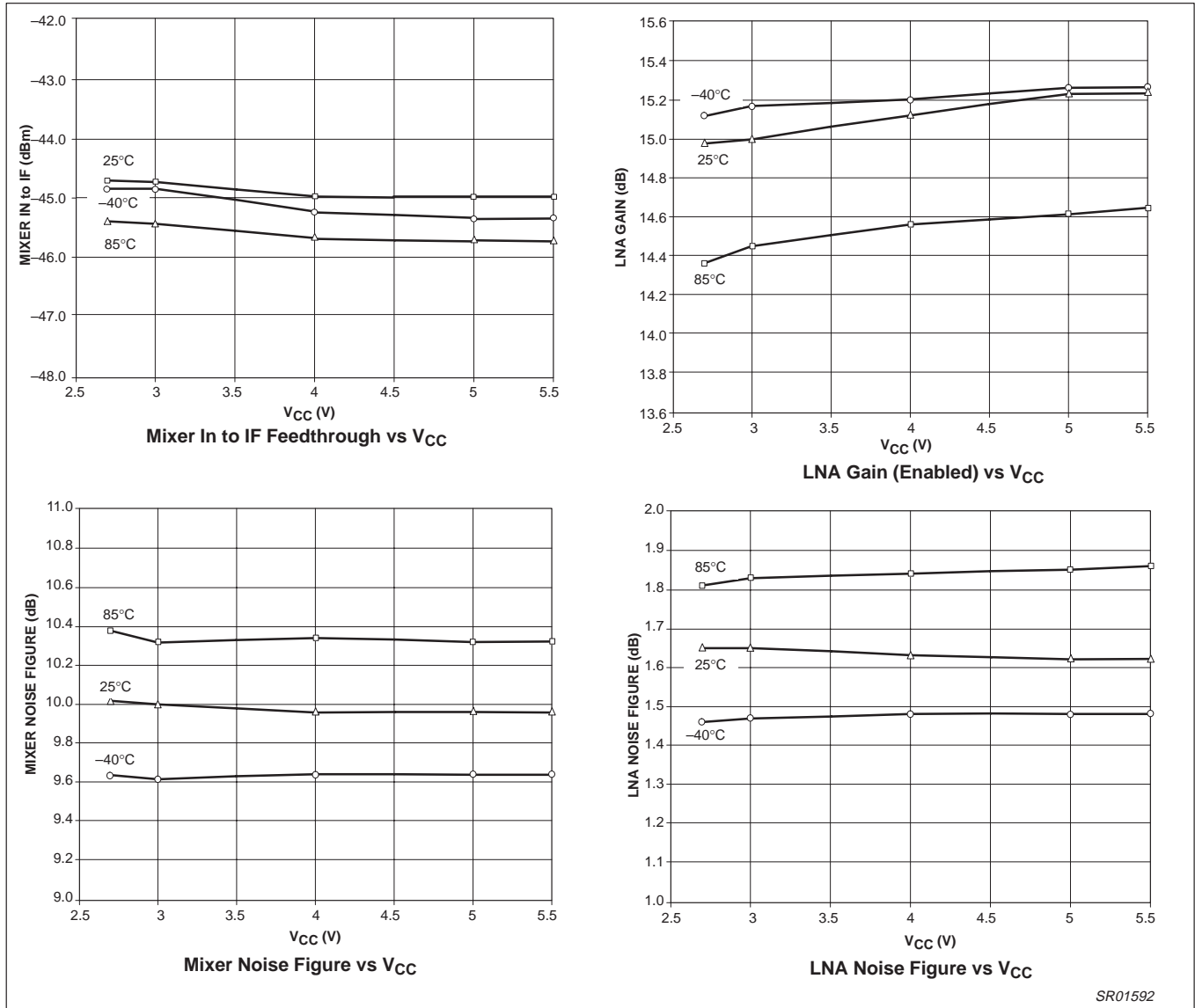

Figure 5.

1GHz low voltage LNA and mixer

SA631

PERFORMANCE CHARACTERISTICS



SR01592

Figure 6.

1GHz low voltage LNA and mixer

SA631

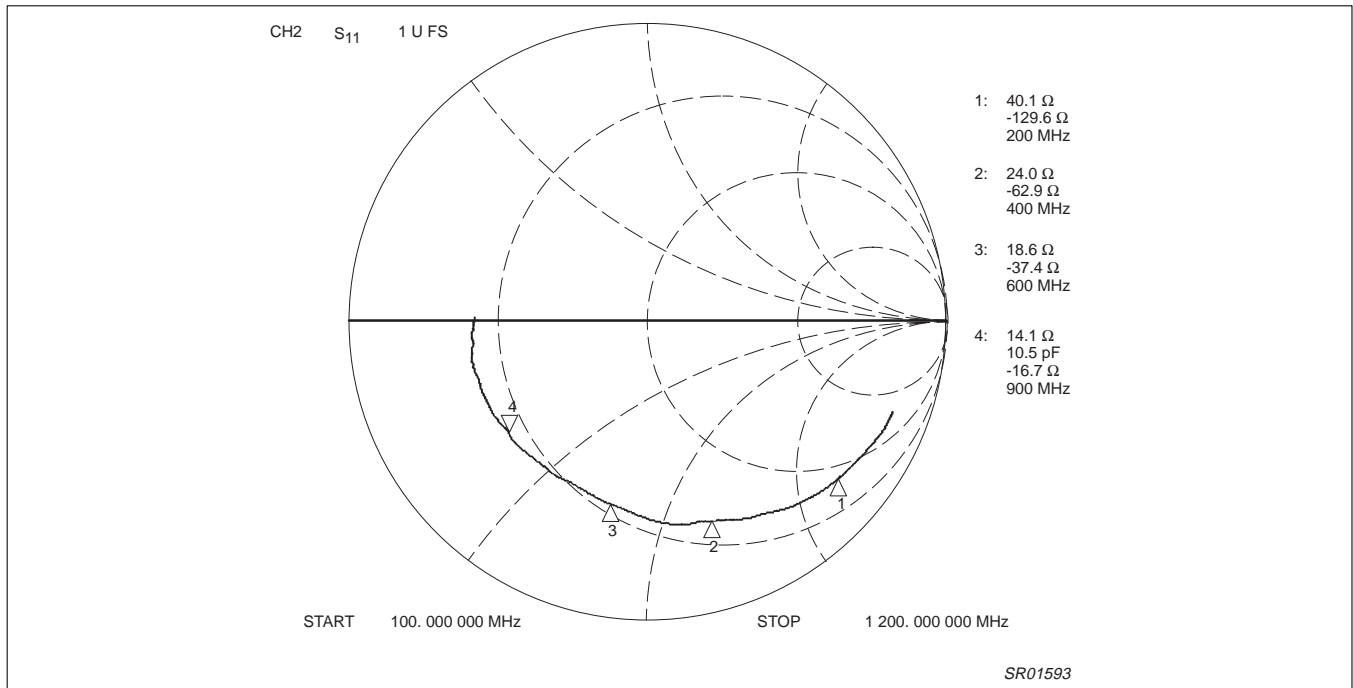

Figure 7. Typical S₁₁ of LNA at 3V

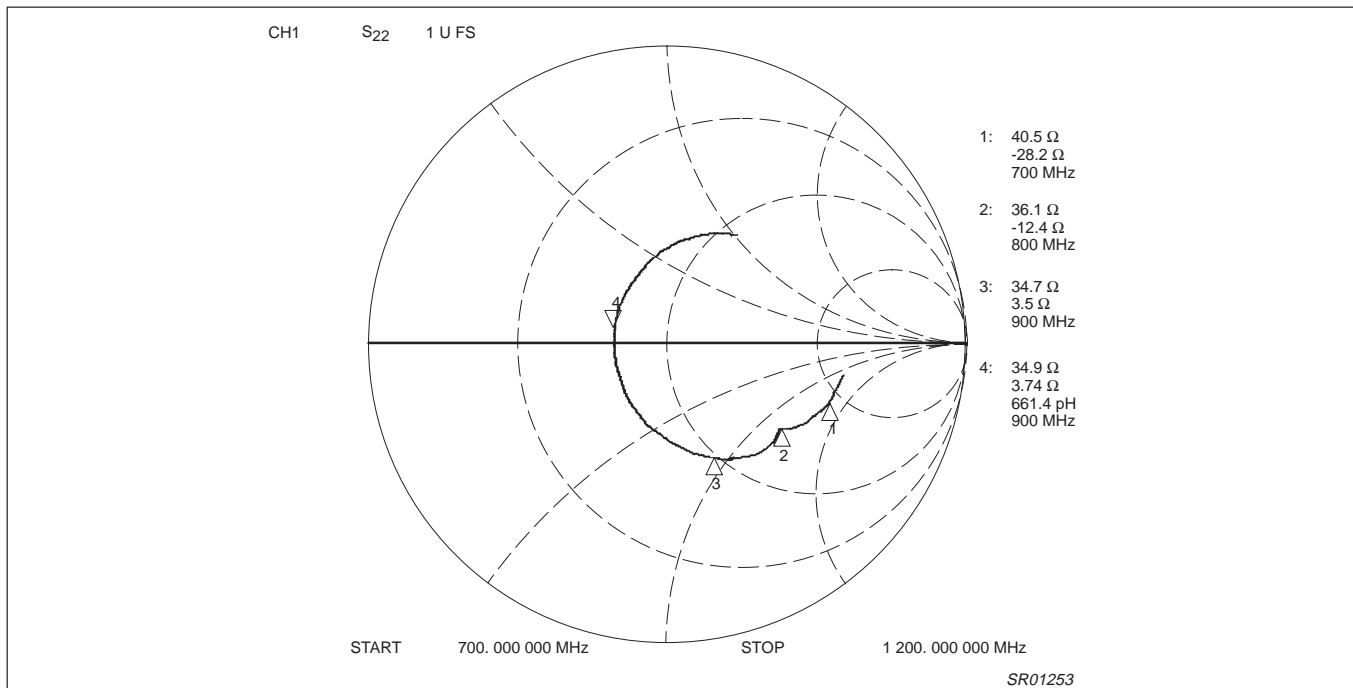

Figure 8. Typical S₂₂ of LNA at 3V

1GHz low voltage LNA and mixer

SA631

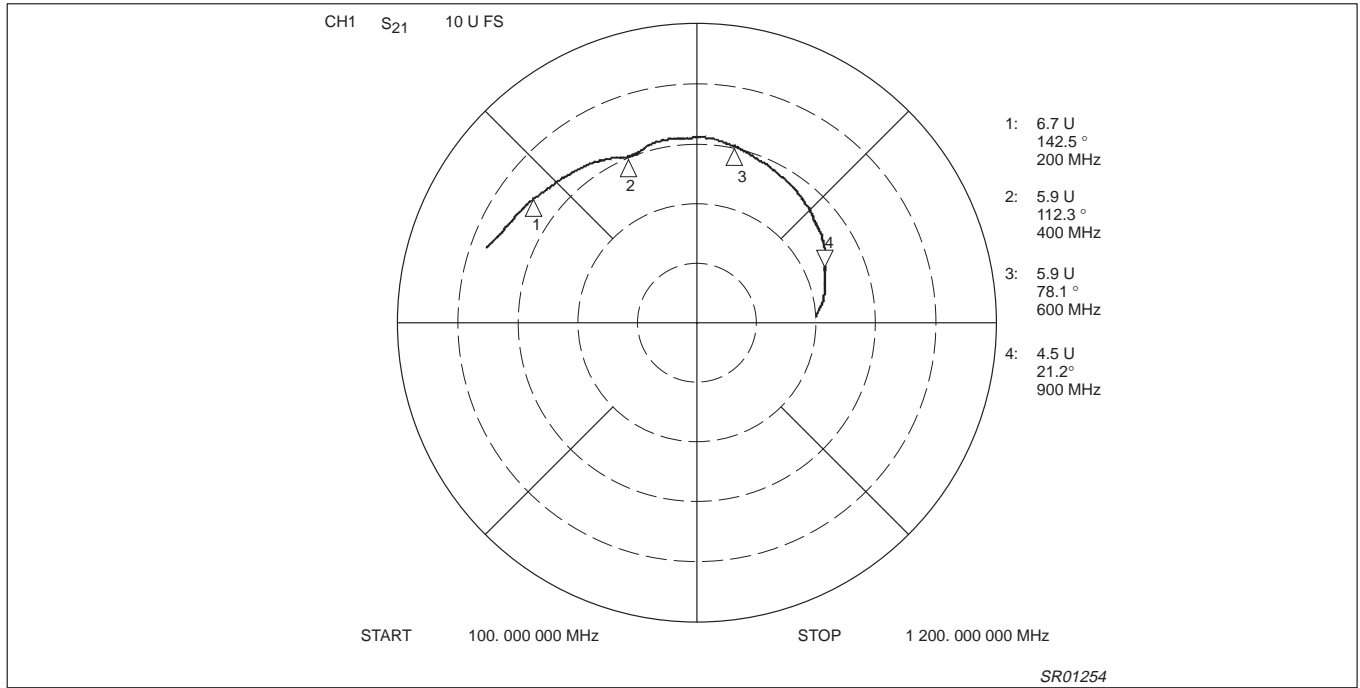

Figure 9. Typical S_{21} of LNA at 3V

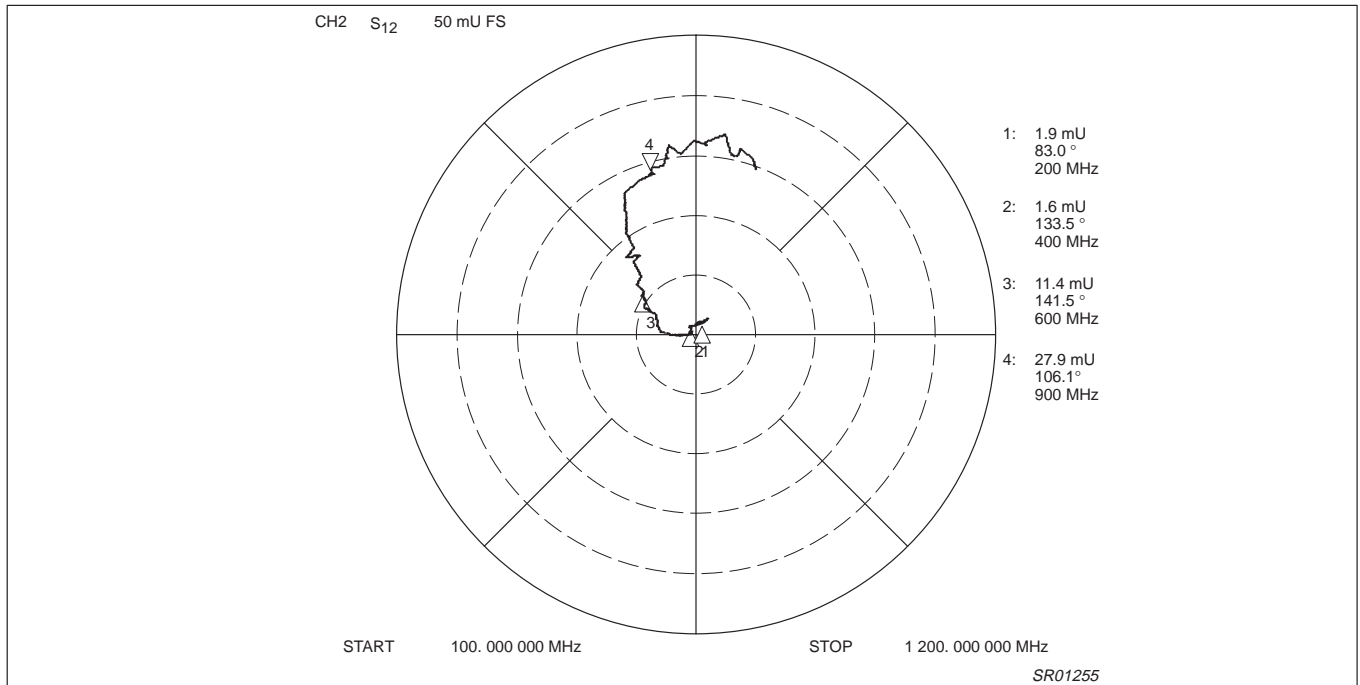

Figure 10. Typical S_{12} of LNA at 3V

1GHz low voltage LNA and mixer

SA631

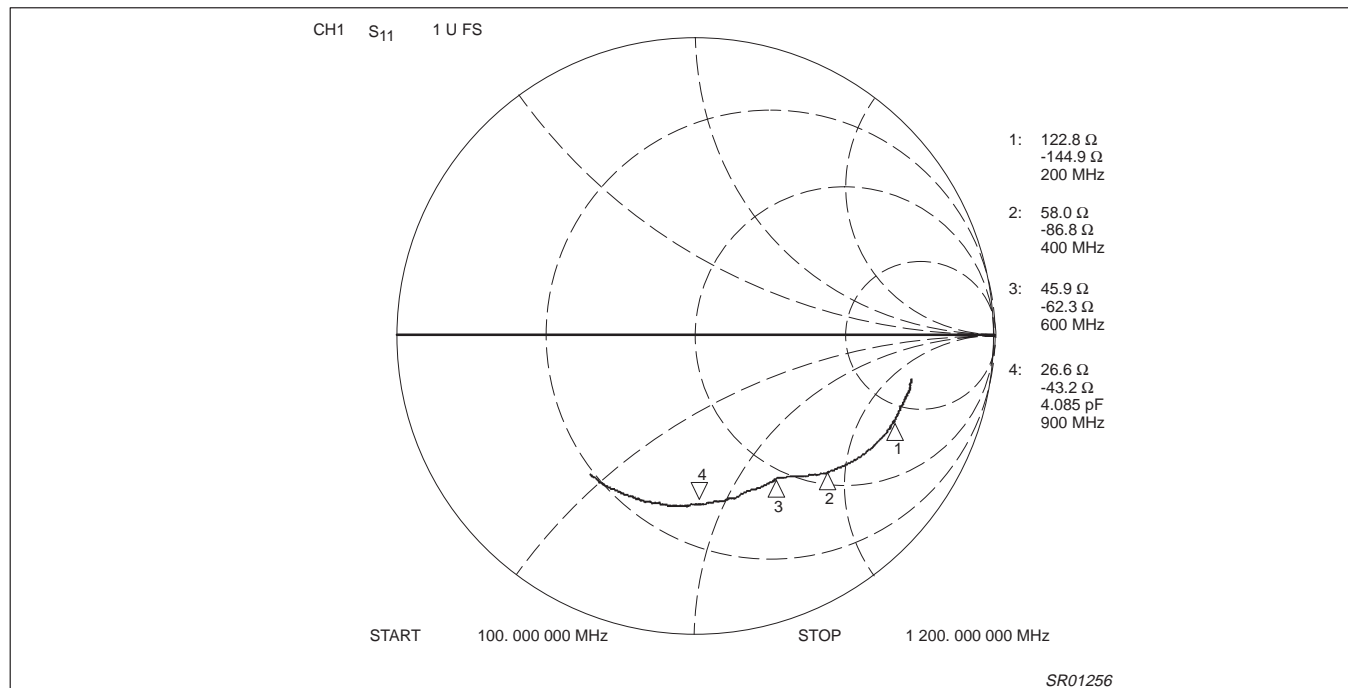

Figure 11. Typical S₁₁ of Mixer at 3V

1GHz low voltage LNA and mixer

SA631

Table 2. Typical S-Parameters of LNA at 3V

LNA								
Freq (MHz)	S ₁₁ (U)	<S ₁₁ (deg)	S ₂₁ (U)	<S ₂₁ (deg)	S ₁₂ (U)	<S ₁₂ (deg)	S ₂₂ (U)	<S ₂₂ (deg)
100	0.86	-20	7.4	160	0.001	91.91	0.59	-9.62
122	0.86	-24	7.1	156	0.001	62	0.58	-11.71
144	0.85	-28	7.0	151	0.001	105.42	0.58	-13.86
166	0.83	-32	6.9	148	0.000	91.65	0.57	-15.89
188	0.82	-36	6.8	144	0.002	100.23	0.57	-17.80
210	0.81	-41	6.7	140	0.002	73.57	0.56	-20.05
232	0.80	-45	6.6	136	0.002	99.70	0.55	-22.37
254	0.79	-48	6.5	133	0.001	84.00	0.54	-24.60
276	0.78	-52	6.4	130	0.001	103.18	0.53	-26.89
298	0.76	-56	6.3	126	0.002	94.33	0.52	-28.72
320	0.75	-59	6.3	123	0.002	66.98	0.51	-30.98
342	0.73	-63	6.2	119	0.002	108.53	0.50	-32.79
364	0.71	-66	6.1	116	0.002	118.13	0.48	-34.68
386	0.70	-69	6.0	113	0.001	103.4	0.47	-36.06
408	0.69	-72	5.9	111	0.001	175.94	0.46	-36.64
430	0.68	-76	5.9	109	0.004	174.1	0.45	-37.21
452	0.69	-78	6.0	106	0.006	162.02	0.46	-38.41
474	0.68	-82	6.1	102	0.007	160.07	0.47	-41.54
496	0.67	-85	6.1	97	0.008	153.6	0.47	-45.75
518	0.66	-89	6.1	93	0.010	146.17	0.46	-50.35
540	0.65	-92	6.1	89	0.009	142.13	0.45	-54.73
562	0.63	-96	6.1	85	0.010	138.49	0.43	-59.16
584	0.62	-99	6.0	81	0.011	146.17	0.42	-63.93
606	0.62	-102	5.9	77	0.011	140.55	0.40	-68.56
628	0.61	-104	5.8	72	0.013	137.2	0.38	-73.48
650	0.61	-107	5.7	69	0.013	130.62	0.36	-78.19
672	0.60	-109	5.7	65	0.016	129.77	0.34	-83.75
694	0.60	-112	5.6	61	0.016	131.94	0.31	-89.81
716	0.59	-115	5.5	57	0.017	128.67	0.29	-96.92
738	0.59	-118	5.5	53	0.019	127.53	0.27	-104.48
760	0.59	-121	5.3	48	0.021	123.42	0.24	-112.81
782	0.59	-124	5.3	44	0.021	122.31	0.22	-122.41
804	0.59	-126	5.1	40	0.022	119.52	0.21	-132.81
826	0.59	-129	5.0	36	0.024	118.29	0.19	-145.39
848	0.59	-132	4.9	31	0.026	115.98	0.18	-159.13
870	0.59	-135	4.8	26	0.027	111.9	0.17	-175.11
892	0.59	-138	4.6	22	0.028	108.11	0.18	169.02
914	0.59	-142	4.5	18	0.028	105.92	0.19	154.96
936	0.59	-144	4.3	14	0.028	106.13	0.20	141.94
958	0.59	-148	4.2	9	0.030	99.79	0.22	130.27
980	0.59	-151	4.0	4	0.031	99.30	0.24	119.5
1002	0.59	-153	3.8	0	0.031	94.81	0.26	110.61
1024	0.59	-157	3.6	-2	0.032	90.91	0.28	102.16
1046	0.59	-160	3.5	-6	0.032	85.65	0.30	94.98
1068	0.59	-164	3.3	-10	0.033	86.10	0.33	88.45
1090	0.59	-167	3.2	-14	0.033	80.59	0.35	82.47
1112	0.59	-170	3.0	-18	0.031	79.18	0.36	77.17
1134	0.58	-172	2.8	-22	0.030	46.32	0.38	71.98
1156	0.58	-175	2.7	-25	0.031	78.57	0.39	67.45
1178	0.57	-178	2.5	-28	0.031	73.66	0.41	62.73
1200	0.57	178	2.4	-31	0.029	71.78	0.42	58.87

1GHz low voltage LNA and mixer

SA631

Table 3. Typical S-Parameters of Mixer at 3V

Mixer		
Freq (MHz)	$ S_{11} $ (U)	$\angle S_{11}$ (deg)
100	0.73	-11
122	0.73	-147
144	0.72	-16
166	0.72	-19
188	0.72	-21
210	0.71	-24
232	0.70	-27
254	0.70	-29
276	0.69	-32
298	0.68	-34
320	0.67	-37
342	0.66	-39
364	0.64	-42
386	0.63	-44
408	0.62	-46
430	0.61	-48
452	0.59	-50
474	0.58	-52
496	0.57	-53
518	0.56	-54
540	0.55	-56
562	0.55	-57
584	0.54	-59
606	0.54	-61
628	0.54	-62
650	0.54	-64

Mixer		
Freq (MHz)	$ S_{11} $ (U)	$\angle S_{11}$ (deg)
672	0.54	-65
694	0.54	-67
716	0.54	-69
738	0.54	-71
760	0.54	-73
782	0.55	-76
804	0.55	-78
826	0.55	-80
848	0.55	-82
870	0.55	-85
892	0.56	-87
914	0.55	-90
936	0.56	-93
958	0.56	-96
980	0.56	-98
1002	0.56	-101
1024	0.57	-104
1046	0.57	-106
1068	0.57	-110
1090	0.57	-112
1112	0.57	-115
1134	0.57	-118
1156	0.57	-121
1178	0.57	-124
1200	0.57	-127

1GHz low voltage LNA and mixer

SA631

SSOP20: plastic shrink small outline package; 20 leads; body width 4.4 mm

SOT266-1

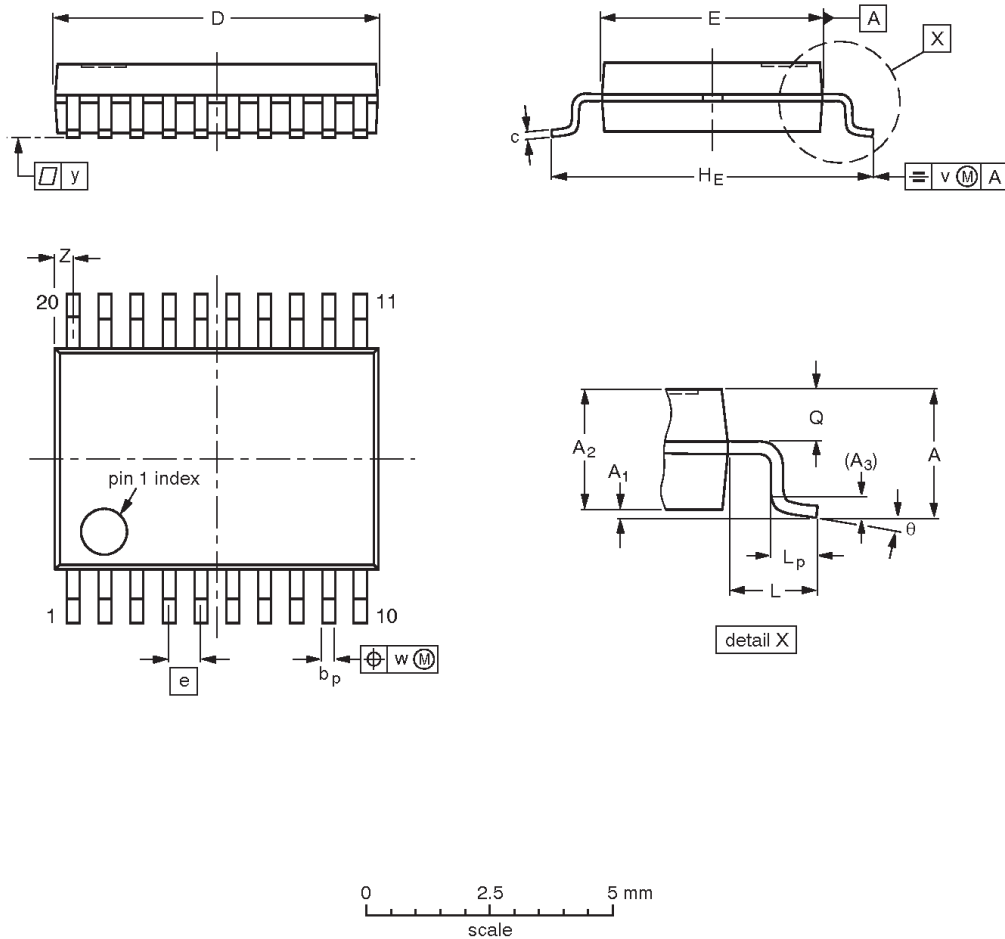

DIMENSIONS (mm are the original dimensions)

UNIT	A max.	A ₁	A ₂	A ₃	b _p	c	D ⁽¹⁾	E ⁽¹⁾	e	H _E	L	L _p	Q	v	w	y	Z ⁽¹⁾	θ
mm	1.5	0.15 0	1.4 1.2	0.25	0.32 0.20	0.20 0.13	6.6 6.4	4.5 4.3	0.65	6.6 6.2	1.0	0.75 0.45	0.65 0.45	0.2	0.13	0.1	0.48 0.18	10° 0°

Note

1. Plastic or metal protrusions of 0.20 mm maximum per side are not included.

OUTLINE VERSION	REFERENCES				EUROPEAN PROJECTION	ISSUE DATE
	IEC	JEDEC	EIAJ			
SOT266-1						90-04-05 95-02-25

1GHz low voltage LNA and mixer

SA631

NOTES

1GHz low voltage LNA and mixer

SA631

Data sheet status

Data sheet status	Product status	Definition [1]
Objective specification	Development	This data sheet contains the design target or goal specifications for product development. Specification may change in any manner without notice.
Preliminary specification	Qualification	This data sheet contains preliminary data, and supplementary data will be published at a later date. Philips Semiconductors reserves the right to make changes at any time without notice in order to improve design and supply the best possible product.
Product specification	Production	This data sheet contains final specifications. Philips Semiconductors reserves the right to make changes at any time without notice in order to improve design and supply the best possible product.

[1] Please consult the most recently issued datasheet before initiating or completing a design.

Definitions

Short-form specification — The data in a short-form specification is extracted from a full data sheet with the same type number and title. For detailed information see the relevant data sheet or data handbook.

Limiting values definition — Limiting values given are in accordance with the Absolute Maximum Rating System (IEC 134). Stress above one or more of the limiting values may cause permanent damage to the device. These are stress ratings only and operation of the device at these or at any other conditions above those given in the Characteristics sections of the specification is not implied. Exposure to limiting values for extended periods may affect device reliability.

Application information — Applications that are described herein for any of these products are for illustrative purposes only. Philips Semiconductors make no representation or warranty that such applications will be suitable for the specified use without further testing or modification.

Disclaimers

Life support — These products are not designed for use in life support appliances, devices or systems where malfunction of these products can reasonably be expected to result in personal injury. Philips Semiconductors customers using or selling these products for use in such applications do so at their own risk and agree to fully indemnify Philips Semiconductors for any damages resulting from such application.

Right to make changes — Philips Semiconductors reserves the right to make changes, without notice, in the products, including circuits, standard cells, and/or software, described or contained herein in order to improve design and/or performance. Philips Semiconductors assumes no responsibility or liability for the use of any of these products, conveys no license or title under any patent, copyright, or mask work right to these products, and makes no representations or warranties that these products are free from patent, copyright, or mask work right infringement, unless otherwise specified.

Philips Semiconductors
811 East Arques Avenue
P.O. Box 3409
Sunnyvale, California 94088-3409
Telephone 800-234-7381

© Copyright Philips Electronics North America Corporation 1998
All rights reserved. Printed in U.S.A.

Date of release: 01-98

Document order number:

9397 750 03414

Let's make things better.

SUNSTAR 商斯达实业集团是集研发、生产、工程、销售、代理经销、技术咨询、信息服务等为一体的高科技企业，是专业高科技电子产品生产厂家，是具有 10 多年历史的专业电子元器件供应商，是中国最早和最大的仓储式连锁规模经营大型综合电子零部件代理分销商之一，是一家专业代理和分销世界各大品牌 IC 芯片和电子元器件的连锁经营综合性国际公司，专业经营进口、国产名厂名牌电子元件，型号、种类齐全。在香港、北京、深圳、上海、西安、成都等全国主要电子市场设有直属分公司和产品展示展销窗口门市部专卖店及代理分销商，已在全国范围内建成强大统一的供货和代理分销网络。我们专业代理经销、开发生产电子元器件、集成电路、传感器、微波光电元器件、工控机/DOC/DOM 电子盘、专用电路、单片机开发、MCU/DSP/ARM/FPGA 软件硬件、二极管、三极管、模块等，是您可靠的一站式现货配套供应商、方案提供商、部件功能模块开发配套商。商斯达实业公司拥有庞大的资料库，有数位毕业于著名高校——有中国电子工业摇篮之称的西安电子科技大学（西军电）并长期从事国防尖端科技研究的高级工程师为您精挑细选、量身订做各种高科技电子元器件，并解决各种技术问题。

微波光电部专业代理经销高频、微波、光纤、光电元器件、组件、部件、模块、整机；电磁兼容元器件、材料、设备；微波 CAD、EDA 软件、开发测试仿真工具；微波、光纤仪器仪表。欢迎国外高科技微波、光纤厂商将优秀产品介绍到中国、共同开拓市场。长期大量现货专业批发高频、微波、卫星、光纤、电视、CATV 器件：晶振、VCO、连接器、PIN 开关、变容二极管、开关二极管、低噪晶体管、功率电阻及电容、放大器、功率管、MMIC、混频器、耦合器、功分器、振荡器、合成器、衰减器、滤波器、隔离器、环行器、移相器、调制解调器；光电子元件和组件：红外发射管、红外接收管、光电开关、光敏管、发光二极管和发光二极管组件、半导体激光二极管和激光器组件、光电探测器和光接收组件、光发射接收模块、光纤激光器和光放大器、光调制器、光开关、DWDM 用光发射和接收器件、用户接入系统光收发器件与模块、光纤连接器、光纤跳线/尾纤、光衰减器、光纤适配器、光隔离器、光耦合器、光环行器、光复用器/转换器；无线收发芯片和模组、蓝牙芯片和模组。

更多产品请看本公司产品专用销售网站：

商斯达中国传感器科技信息网：<http://www.sensor-ic.com/>

商斯达工控安防网：<http://www.pc-ps.net/>

商斯达电子元器件网：<http://www.sunstare.com/>

商斯达微波光电产品网：[HTTP://www.rfoe.net/](http://www.rfoe.net/)

商斯达消费电子产品网：<http://www.icasic.com/>

商斯达实业科技产品网：<http://www.sunstars.cn/> 微波元器件销售热线：

地址：深圳市福田区福华路福庆街鸿图大厦 1602 室

电话：0755-82884100 83397033 83396822 83398585

传真：0755-83376182 (0) 13823648918 MSN: SUNS8888@hotmail.com

邮编：518033 E-mail:szss20@163.com QQ: 195847376

深圳赛格展销部：深圳华强北路赛格电子市场 2583 号 电话：0755-83665529 25059422

技术支持：0755-83394033 13501568376

欢迎索取免费详细资料、设计指南和光盘；产品凡多，未能尽录，欢迎来电查询。

北京分公司：北京海淀区知春路 132 号中发电子大厦 3097 号

TEL: 010-81159046 82615020 13501189838 FAX: 010-62543996

上海分公司：上海市北京东路 668 号上海赛格电子市场 D125 号

TEL: 021-28311762 56703037 13701955389 FAX: 021-56703037

西安分公司：西安高新开发区 20 所(中国电子科技集团导航技术研究所)

西安劳动南路 88 号电子商城二楼 D23 号

TEL: 029-81022619 13072977981 FAX:029-88789382

SUNSTAR 商斯达实业集团是集研发、生产、工程、销售、代理经销、技术咨询、信息服务等为一体的高科技企业，是专业高科技电子产品生产厂家，是具有 10 多年历史的专业电子元器件供应商，是中国最早和最大的仓储式连锁规模经营大型综合电子零部件代理分销商之一，是一家专业代理和分销世界各大品牌 IC 芯片和电子元器件的连锁经营综合性国际公司，专业经营进口、国产名厂名牌电子元件，型号、种类齐全。在香港、北京、深圳、上海、西安、成都等全国主要电子市场设有直属分公司和产品展示展销窗口门市部专卖店及代理分销商，已在全国范围内建成强大统一的供货和代理分销网络。我们专业代理经销、开发生产电子元器件、集成电路、传感器、微波光电元器件、工控机/DOC/DOM 电子盘、专用电路、单片机开发、MCU/DSP/ARM/FPGA 软件硬件、二极管、三极管、模块等，是您可靠的一站式现货配套供应商、方案提供商、部件功能模块开发配套商。商斯达实业公司拥有庞大的资料库，有数位毕业于著名高校——有中国电子工业摇篮之称的西安电子科技大学（西军电）并长期从事国防尖端科技研究的高级工程师为您精挑细选、量身订做各种高科技电子元器件，并解决各种技术问题。

微波光电部专业代理经销高频、微波、光纤、光电元器件、组件、部件、模块、整机；电磁兼容元器件、材料、设备；微波 CAD、EDA 软件、开发测试仿真工具；微波、光纤仪器仪表。欢迎国外高科技微波、光纤厂商将优秀产品介绍到中国、共同开拓市场。长期大量现货专业批发高频、微波、卫星、光纤、电视、CATV 器件：晶振、VCO、连接器、PIN 开关、变容二极管、开关二极管、低噪晶体管、功率电阻及电容、放大器、功率管、MMIC、混频器、耦合器、功分器、振荡器、合成器、衰减器、滤波器、隔离器、环行器、移相器、调制解调器；光电子元件和组件：红外发射管、红外接收管、光电开关、光敏管、发光二极管和发光二极管组件、半导体激光二极管和激光器组件、光电探测器和光接收组件、光发射接收模块、光纤激光器和光放大器、光调制器、光开关、DWDM 用光发射和接收器件、用户接入系统光收发器件与模块、光纤连接器、光纤跳线/尾纤、光衰减器、光纤适配器、光隔离器、光耦合器、光环行器、光复用器/转换器；无线收发芯片和模组、蓝牙芯片和模组。

更多产品请看本公司产品专用销售网站：

商斯达中国传感器科技信息网：<http://www.sensor-ic.com/>

商斯达工控安防网：<http://www.pc-ps.net/>

商斯达电子元器件网：<http://www.sunstare.com/>

商斯达微波光电产品网：[HTTP://www.rfoe.net/](http://www.rfoe.net/)

商斯达消费电子产品网：<http://www.icasic.com/>

商斯达实业科技产品网：<http://www.sunstars.cn/> 微波元器件销售热线：

地址：深圳市福田区福华路福庆街鸿图大厦 1602 室

电话：0755-82884100 83397033 83396822 83398585

传真：0755-83376182 (0) 13823648918 MSN: SUNS8888@hotmail.com

邮编：518033 E-mail:szss20@163.com QQ: 195847376

深圳赛格展销部：深圳华强北路赛格电子市场 2583 号 电话：0755-83665529 25059422

技术支持：0755-83394033 13501568376

欢迎索取免费详细资料、设计指南和光盘；产品凡多，未能尽录，欢迎来电查询。

北京分公司：北京海淀区知春路 132 号中发电子大厦 3097 号

TEL: 010-81159046 82615020 13501189838 FAX: 010-62543996

上海分公司：上海市北京东路 668 号上海赛格电子市场 D125 号

TEL: 021-28311762 56703037 13701955389 FAX: 021-56703037

西安分公司：西安高新开发区 20 所(中国电子科技集团导航技术研究所)

西安劳动南路 88 号电子商城二楼 D23 号

TEL: 029-81022619 13072977981 FAX:029-88789382