

# DATA SHEET

**TZA3031AHL; TZA3031BHL;  
TZA3031U**  
SDH/SONET STM1/OC3 laser  
drivers

Preliminary specification  
Supersedes data of 1998 Jul 29  
File under Integrated Circuits, IC19

1999 Aug 24

**SDH/SONET STM1/OC3 laser drivers****TZA3031AHL; TZA3031BHL;  
TZA3031U****FEATURES**

- 155 Mb/s data input, both Current-Mode Logic (CML) and Positive Emitter Coupled Logic (PECL) compatible; maximum 800 mV (p-p)
- Adaptive laser output control with dual loop, stabilizing optical ONE and ZERO levels
- Optional external control of laser modulation and biasing currents (non-adaptive)
- Automatic laser shutdown
- Few external components required
- Rise and fall times of 120 ps (typical value)
- Jitter <50 mUI (p-p)
- RF output current sinking capability of 60 mA
- Bias current sinking capability of 90 mA
- Power dissipation of 430 mW (typical value)
- Low cost LQFP32 plastic package
- Single 5 V power supply.

**TZA3031AHL**

- Laser alarm output for signalling extremely low and high bias current conditions.

**TZA3031BHL**

- Extra STM1 155 Mb/s loop mode input; both CML and PECL compatible.

**TZA3031U**

- Bare die version with combined bias alarm and loop mode functionality.

**APPLICATIONS**

- SDH/SONET STM1/OC3 optical transmission systems
- SDH/SONET STM1/OC3 optical laser modules.

**GENERAL DESCRIPTION**

The TZA3031AHL, TZA3031BHL and TZA3031U are fully integrated laser drivers for STM1/OC3 (155 Mb/s) systems, incorporating the RF path between the data multiplexer and the laser diode. Since the dual loop bias and modulation control circuits are integrated on the IC, the external component count is low. Only decoupling capacitors and adjustment resistors are required.

The TZA3031AHL features an alarm function for signalling extreme bias current conditions. The alarm low and high threshold levels can be adjusted to suit the application using only a resistor or a current Digital-to-Analog Converter (DAC).

The TZA3031BHL is provided with an additional RF data input to facilitate remote (loop mode) system testing.

The TZA3031U is a bare die version for use in compact laser module designs. The die contains 40 pads and features the combined functionality of the TZA3031AHL and the TZA3031BHL.

**ORDERING INFORMATION**

TYPE NUMBER	PACKAGE		
	NAME	DESCRIPTION	VERSION
TZA3031AHL	LQFP32	plastic low profile quad flat package; 32 leads; body 5 × 5 × 1.4 mm	SOT401-1
TZA3031BHL			
TZA3031U	–	bare die; 2000 × 2000 × 380 μm	–

SDH/SONET STM1/OC3 laser drivers

TZA3031AHL; TZA3031BHL;  
TZA3031U

BLOCK DIAGRAMS

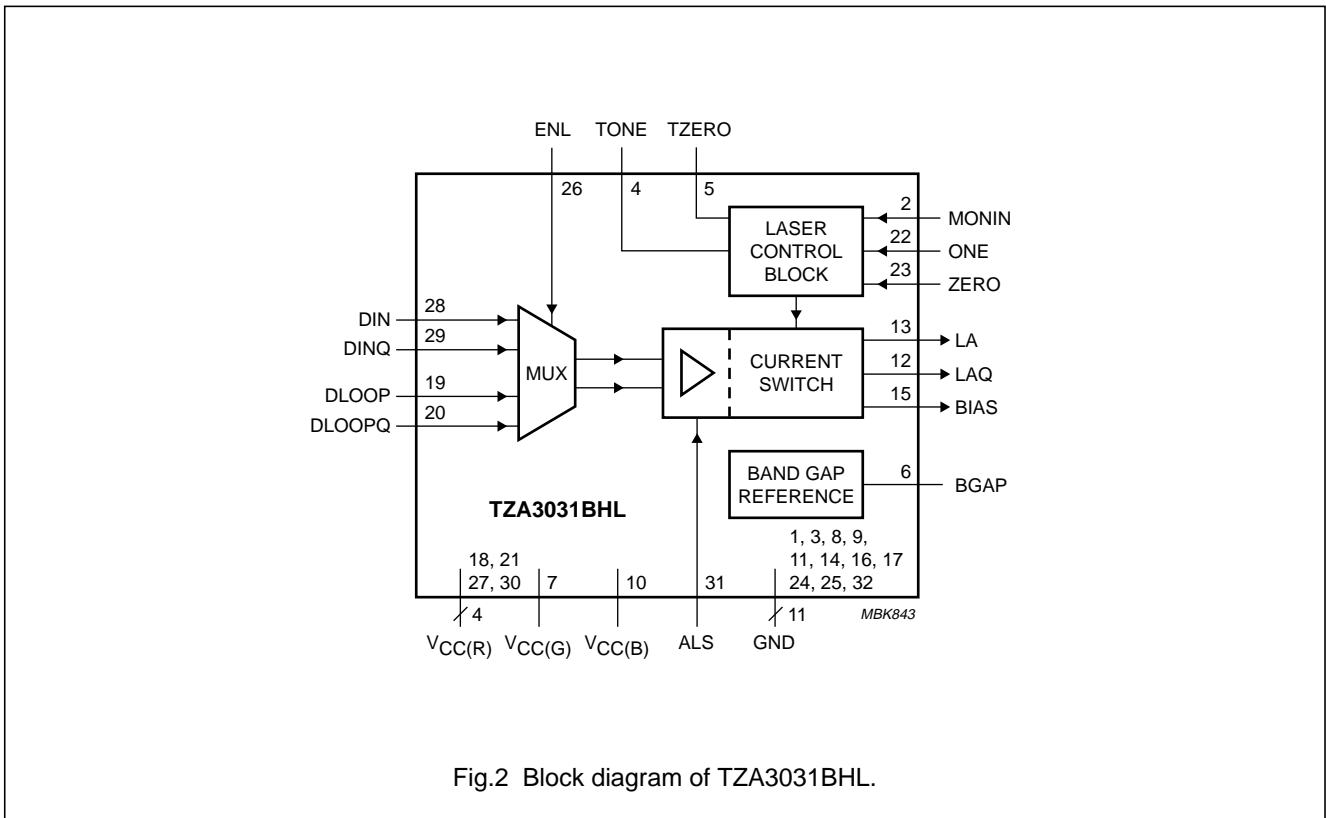
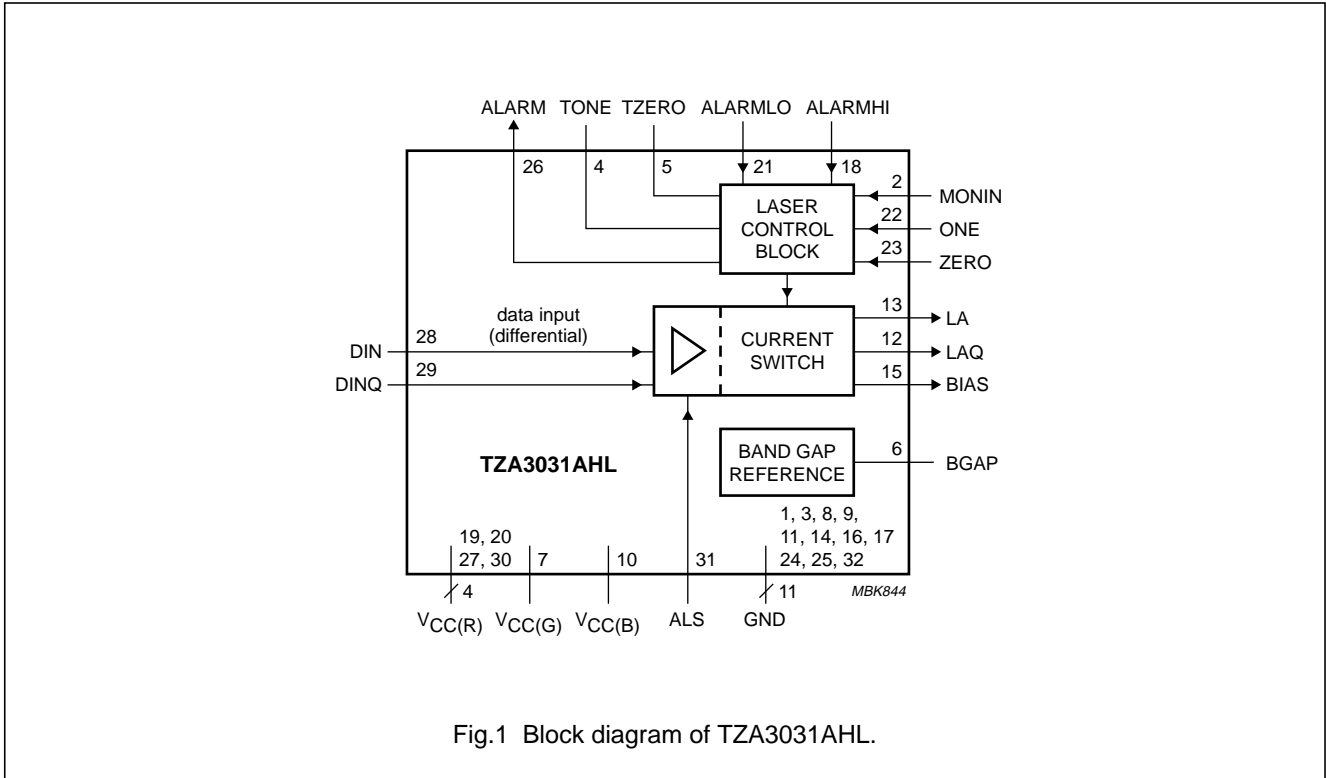

## SDH/SONET STM1/OC3 laser drivers

TZA3031AHL; TZA3031BHL;  
TZA3031U

## PINNING

SYMBOL	PIN		PAD	DESCRIPTION
	TZA3031AHL	TZA3031BHL	TZA3031U	
GND	1	1	1	ground
MONIN	2	2	2	monitor photodiode current input
GND	3	3	3	ground
IGM	–	–	4	not used; leave unbonded
TONE	4	4	5	connection for external capacitor used to set optical ONE control loop time constant (optional)
TZERO	5	5	6	connection for external capacitor used to set optical ZERO control loop time constant (optional)
BGAP	6	6	7	connection for external band gap decoupling capacitor
V <sub>CC(G)</sub>	7	7	8	supply voltage (green domain)
V <sub>CC(G)</sub>	–	–	9	supply voltage (green domain)
GND	8	8	10	ground
GND	9	9	11	ground
V <sub>CC(B)</sub>	10	10	12	supply voltage (blue domain)
V <sub>CC(B)</sub>	–	–	13	supply voltage (blue domain)
GND	11	11	14	ground
LAQ	12	12	15	laser modulation output inverted
LA	13	13	16	laser modulation output
GND	14	14	17	ground
BIAS	15	15	18	laser bias current output
GND	16	16	19	ground
GND	17	17	20	ground
GND	–	–	21	ground
ALARMHI	18	–	22	maximum bias current alarm reference level input
V <sub>CC(R)</sub>	–	18	23	supply voltage (red domain)
V <sub>CC(R)</sub>	19	–	–	supply voltage (red domain)
DLOOP	–	19	24	loop mode data input
V <sub>CC(R)</sub>	20	–	–	supply voltage (red domain)
DLOOPQ	–	20	25	loop mode data input inverted
V <sub>CC(R)</sub>	–	–	26	supply voltage (red domain)
ALARMLO	21	–	27	minimum bias current alarm reference level input
V <sub>CC(R)</sub>	–	21	–	supply voltage (red domain)
ONE	22	22	28	optical ONE reference level input
ZERO	23	23	29	optical ZERO reference level input
GND	24	24	30	ground
GND	25	25	31	ground
ALARM	26	–	32	alarm output
ENL	–	26	33	loop mode enable input
V <sub>CC(R)</sub>	27	27	34	supply voltage (red domain)

SDH/SONET STM1/OC3 laser drivers

TZA3031AHL; TZA3031BHL;  
TZA3031U

SYMBOL	PIN		PAD	DESCRIPTION
	TZA3031AHL	TZA3031BHL	TZA3031U	
DIN	28	28	35	data input
DINQ	29	29	36	data input inverted
V <sub>CC(R)</sub>	30	30	37	supply voltage (red domain)
ALS	31	31	38	automatic laser shutdown input
GND	32	32	39	ground
GND	-	-	40	ground

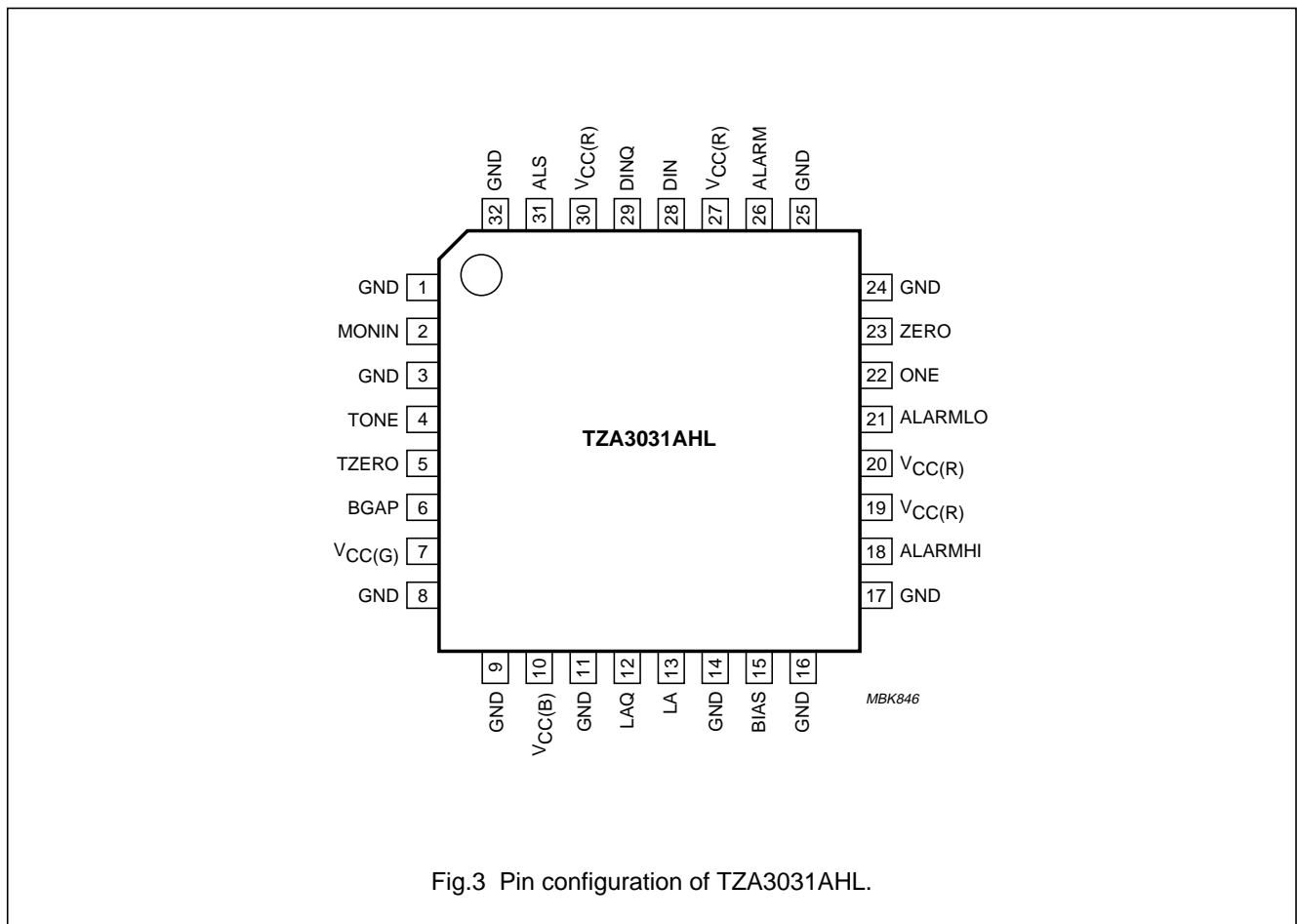

Fig.3 Pin configuration of TZA3031AHL.

SDH/SONET STM1/OC3 laser drivers

TZA3031AHL; TZA3031BHL;  
TZA3031U

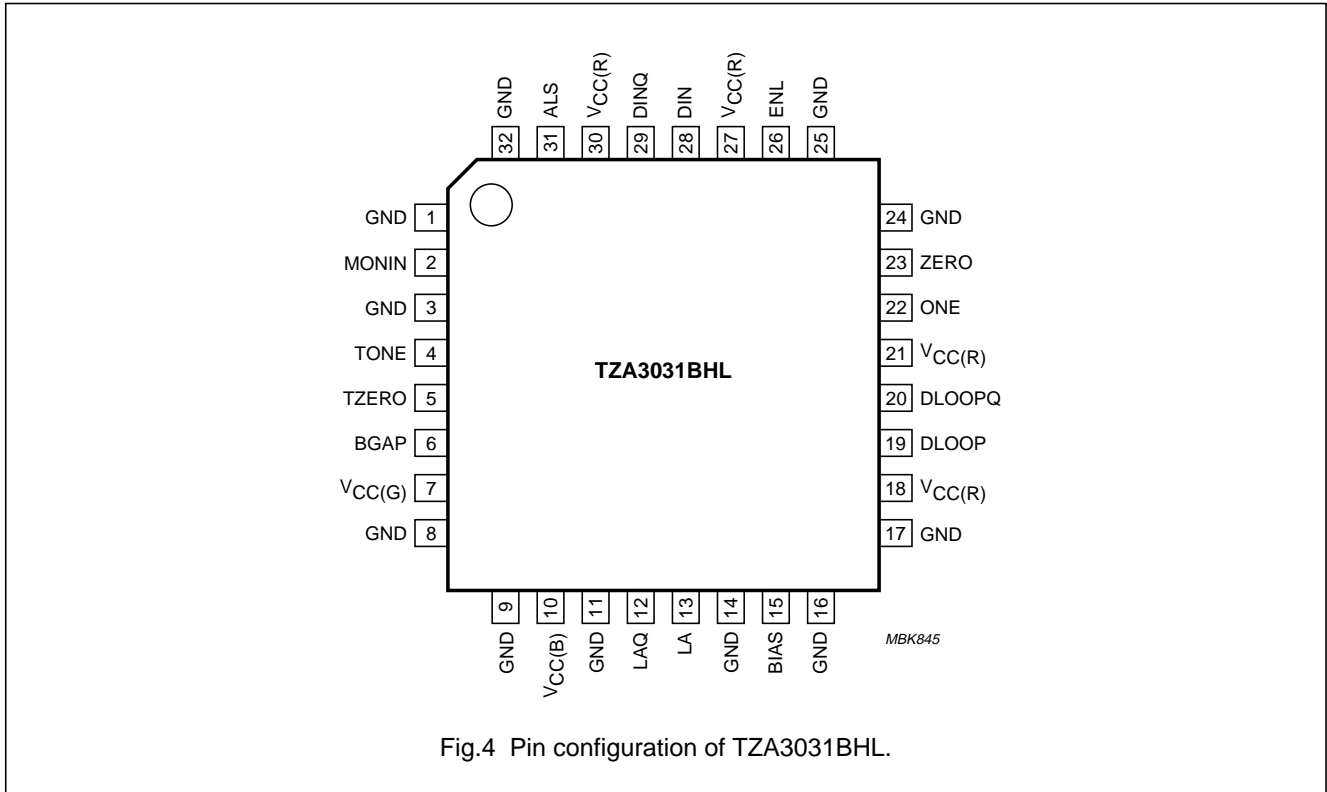

Fig.4 Pin configuration of TZA3031BHL.

**FUNCTIONAL DESCRIPTION**

The TZA3031AHL, TZA3031BHL and TZA3031U laser drivers accept a 155 Mbits/s STM1 Non-Return to Zero (NRZ) input data stream and generate an output signal with sufficient current to drive a solid state Fabry Perot (FP) or Distributed FeedBack (DFB) laser. They also contain dual loop control circuitry for stabilizing the true laser optical power levels representing logic 1 and logic 0.

The input buffers present a high impedance to the data stream on the differential inputs (pins DIN and DINQ). The input signal can be at CML level of approximately 200 mV (p-p) below the supply voltage, or at PECL level up to 800 mV (p-p). The inputs can be configured to accept CML signals by connecting external 50 Ω pull-up resistors between pins DIN and DINQ to VCC(R). If PECL compatibility is required, the usual Thevenin termination can be applied.

For ECL signals (negative and referenced to ground) the inputs should be AC-coupled to the signal source. If AC-coupling is applied, a constant input signal (either low or high) will bring the device in an undefined state. To avoid this, it is recommended to apply a slight offset to the input stage. The applied offset must be higher than the specified value in Chapter “Characteristics”, but much lower than the applied input voltage swing.

The RF path is fully differential and contains a differential preamplifier and a main amplifier. The main amplifier is designed to handle large peak currents required at the output laser driving stage and is insensitive to supply voltage variations. The output signal from the main amplifier drives a current switch which supplies a guaranteed maximum modulation current of 60 mA at pins LA and LAQ. Pin BIAS delivers a guaranteed maximum DC bias current of up to 90 mA for adjusting the optical laser output to a level above its light emitting threshold.

**Automatic laser control**

A laser with a Monitor PhotoDiode (MPD) is required for the laser control circuit (see Figs 6 and 7).

The MPD current is proportional to the laser emission and is applied to pin MONIN. The MPD current range is from 100 to 1000 μA (p-p). The input buffer is optimized to cope with MPD capacitances up to 50 pF. To prevent the input buffer breaking into oscillation with a low MPD capacitance, it is required to increase the capacitance to the minimum value specified in Chapter “Characteristics” by connecting an extra capacitor between pin MONIN and VCC(G).

## SDH/SONET STM1/OC3 laser drivers

TZA3031AHL; TZA3031BHL;  
TZA3031U

DC reference currents are applied to pins ZERO and ONE to set the MPD reference levels for laser LOW and laser HIGH. A resistor connected between pin ZERO and  $V_{CC(R)}$  and a resistor connected between pin ONE and  $V_{CC(R)}$  is sufficient, but current DACs can also be used.

The voltages on pins ZERO and ONE are held constant at a level of 1.5 V below  $V_{CC(R)}$ . The reference current applied to pin ZERO is multiplied by 4 and the reference current flowing into pin ONE is multiplied internally by 16.

The reference current and the resistor for the optical ONE regulation loop (modulation current control) can be calculated using the following formulae:

$$I_{ONE} = \frac{1}{16} \times I_{MPD(ONE)} \quad [A] \quad (1)$$

$$R_{ONE} = \frac{1.5}{I_{ONE}} = \frac{24}{I_{MPD(ONE)}} \quad [\Omega] \quad (2)$$

The reference current and resistor for the optical ZERO regulation loop (bias current control) can be calculated using the following formulae:

$$I_{ZERO} = \frac{1}{4} \times I_{MPD(ZERO)} \quad [A] \quad (3)$$

$$R_{ZERO} = \frac{1.5}{I_{ZERO}} = \frac{6}{I_{MPD(ZERO)}} \quad [\Omega] \quad (4)$$

In these formulae,  $I_{MPD(ONE)}$  and  $I_{MPD(ZERO)}$  represent the monitor photodiode current during an optical ONE and an optical ZERO, respectively.

**Example:** A laser is operating at optical output power levels of 0.3 mW for laser HIGH and 0.03 mW for laser LOW (extinction ratio of 10 dB). Suppose the corresponding MPD currents for this type of laser are 260 and 30  $\mu$ A, respectively.

In this example the reference current is

$$I_{ONE} = \frac{1}{16} \times 260 = 16.25 \mu A \text{ and flows into pin ONE.}$$

This current can be set using a current source or simply by a resistor of the appropriate value connected between pin ONE and  $V_{CC(R)}$ . In this example the resistor would be

$$R_{ONE} = \frac{1.5}{16.25} = 92.3 \text{ k}\Omega$$

The reference current at pin ZERO in this example is

$$I_{ZERO} = \frac{1}{4} \times 30 = 7.5 \mu A \text{ and can be set using a resistor}$$

$$R_{ZERO} = \frac{1.5}{7.5} = 200 \text{ k}\Omega$$

It should be noted that the MPD current is stabilized, rather than the actual laser optical output power. Deviations between optical output power and MPD current, known as 'tracking errors', cannot be corrected.

**Designing the modulation and bias loop**

The optical ONE and ZERO regulation loop time constants are determined by on-chip capacitances. If the resulting time constants are found to be too small in a specific application, they can be increased by connecting external capacitors to pins TZERO and TONE, respectively.

The optical ONE loop time constant and bandwidth can be estimated using the following formulae:

$$\tau_{ONE} = (40 \times 10^{-12} + C_{TONE}) \times \frac{80 \times 10^3}{\eta_{LASER}} \quad [s] \quad (5)$$

$$B_{ONE} = \frac{1}{2\pi \times \tau_{ONE}} \quad [Hz] \quad (6)$$

$$B_{ONE} = \frac{\eta_{LASER}}{2\pi \times (40 \times 10^{-12} + C_{TONE}) \times 80 \times 10^3}$$

The optical ZERO loop time constant and bandwidth can be estimated using the following formulae:

$$\tau_{ZERO} = (40 \times 10^{-12} + C_{TZERO}) \times \frac{50 \times 10^3}{\eta_{LASER}} \quad [s] \quad (7)$$

$$B_{ZERO} = \frac{1}{2\pi \times \tau_{ZERO}} \quad [Hz] \quad (8)$$

$$B_{ZERO} = \frac{\eta_{LASER}}{2\pi \times (40 \times 10^{-12} + C_{TZERO}) \times 50 \times 10^3}$$

The term  $\eta_{LASER}$  (dimensionless) in the above formulae is the product of the two terms:

- $\eta_{EO}$  is the electro-optical efficiency which accounts for the steepness of the laser slope. It is the amount of the extra optical output power in W/A of modulation current optical output power.
- R is the monitor photodiode responsivity. It is the amount of the extra monitor photodiode current in A/W optical output power.

## SDH/SONET STM1/OC3 laser drivers

TZA3031AHL; TZA3031BHL;  
TZA3031U

**Example:** A laser with an MPD has the following specifications:  $P_O = 1$  mW,  $I_{th} = 25$  mA,  $\eta_{EO} = 30$  mW/A,  $R = 500$  mA/W. The term  $I_{th}$  is the required threshold current to switch-on the laser. If the laser operates just above the threshold level, it may be assumed that  $\eta_{EO}$  around the optical ZERO level is 50% of  $\eta_{EO}$  around the optical ONE level, due to the decreasing slope near the threshold level.

In this example the resulting bandwidth for the optical ONE regulation loop, without external capacitance, would be:

$$B_{ONE} = \frac{30 \times 10^{-3} \times 500 \times 10^{-3}}{2\pi \times 40 \times 10^{-12} \times 80 \times 10^3} \approx 750 \text{ Hz}$$

The resulting bandwidth for the optical ZERO regulation loop, without external capacitance, would be:

$$B_{ZERO} = \frac{0.5 \times 30 \times 10^{-3} \times 500 \times 10^{-3}}{2\pi \times 40 \times 10^{-12} \times 50 \times 10^3} \approx 600 \text{ Hz}$$

It is not necessary to add additional capacitance with this type of laser.

#### Monitoring the bias and modulation current

Although not recommended, the bias and modulation currents generated by the laser driver can be monitored by measuring the voltages on pins TZERO and TONE, respectively. The relations between these voltages and the corresponding currents are given as transconductance values and are specified in Chapter "Characteristics". The voltages on pins TZERO and TONE range from 1.4 to 3.4 V. The impedance connected at these pins should have an extremely high value. It is mandatory to use a CMOS buffer or an amplifier with an input impedance higher than 100 G $\Omega$  and an extremely low input leakage current (pA range).

#### Manual laser override

The automatic laser control function can be overridden by connecting voltage sources to pins TZERO and TONE to take direct control of, respectively, the bias current source and the modulation current source. The control voltages should be in the range from 1.4 to 3.4 V to sweep the

modulation current through the range from 1 to 60 mA and the bias current through the range from 1 to 90 mA. These current ranges are guaranteed. Depending on the temperature and manufacturing process spread, current values higher than the specified ranges can be achieved. However, bias and modulation currents in excess of the specified range are not supported and should be avoided.

Currents into or out pins TZERO and TONE in excess of 10  $\mu$ A must be avoided to prevent damage of the circuit.

#### Automatic laser shut-down and laser slow start

The laser modulation and bias currents can be rapidly switched off when a HIGH-level (CMOS) is applied to pin ALS. This function allows the circuit to be shut-down in the event of an optical system malfunction. A 25 k $\Omega$  pull-down resistor defaults the input of pin ALS to the non active state.

When a LOW-level is applied to pin ALS, the modulation and bias current slowly increase to the desired values with the typical time constants of  $\tau_{TONE}$  and  $\tau_{TZERO}$ , respectively. This can be used as a laser slow start.

#### Bias alarm for TZA3031AHL

The bias current alarm circuit detects and flags whenever the bias current is outside a predefined range. This feature can detect excessive bias current due to laser aging and laser malfunctioning. The maximum permitted bias current should be applied to pin ALARMHI with an attenuation ratio of 1500; the minimum to pin ALARMLO with an attenuation ratio of 300.

Like the reference currents for the laser current control loop, the alarm reference currents can be set using external resistors connected between pins ALARMHI or ALARMLO and  $V_{CC(R)}$ . The resistor values can be calculated using the following formulae:

$$R_{ALARMHI} = \frac{1.5 \times 1500}{I_{BIAS(max)}} \quad [\Omega] \quad (9)$$

$$R_{ALARMLO} = \frac{1.5 \times 300}{I_{BIAS(min)}} \quad [\Omega] \quad (10)$$



## SDH/SONET STM1/OC3 laser drivers

TZA3031AHL; TZA3031BHL;  
TZA3031U

**Example:** The following reference currents are required to limit the bias current range between 6 and 90 mA:

$$I_{\text{ALARMLO}} = \frac{6 \text{ mA}}{300} = 20 \text{ } \mu\text{A} \text{ and}$$

$$I_{\text{ALARMHI}} = \frac{90 \text{ mA}}{1500} = 60 \text{ } \mu\text{A}$$

The corresponding resistor values are:

$$R_{\text{ALARMHI}} = \frac{1.5 \text{ V} \times 1500}{90 \text{ mA}} = 25 \text{ k}\Omega \text{ and}$$

$$R_{\text{ALARMLO}} = \frac{1.5 \text{ V} \times 300}{6 \text{ mA}} = 75 \text{ k}\Omega$$

If the alarm condition is true, the voltage on pin ALARM goes to HIGH-level (CMOS). This signal could be used, for example, to disable the laser driver by driving pin ALS (a latch is needed in between to prevent oscillation).

#### Loop mode for TZA3031BHL

In the loop mode the total system application can be tested. It allows for uninhibited optical transmission through the fibre front-end (from the photodiode through the transimpedance stage and the data and clock recovery unit, to the laser driver and via the laser back to the fibre). It should be noted that the optical receiver used in conjunction with the TZA3031BHL must have a loop mode output in order to complete the test loop.

A HIGH-level on pin ENL selects the loop mode. By default pin ENL is pulled at LOW-level by a 25 k $\Omega$  pull-down resistor.

#### Power supply connections

Three separate supply domains [labelled  $V_{\text{CC(B)}}$ ,  $V_{\text{CC(G)}}$  and  $V_{\text{CC(R)}}$ ] are used to provide isolation between the high-current outputs, the PECL or CML inputs, and the monitor photodiode current input. The three domains should be individually filtered before being connected to a central  $V_{\text{CC}}$  (see Figs 6 and 7). **All supply pins need to be connected.** The supply levels should be equal and in accordance with the values specified in Chapter "Characteristics".

To maximize power supply isolation, the MPD cathode on the laser should be connected to  $V_{\text{CC(G)}}$  and the laser diode anode to  $V_{\text{CC(B)}}$ . It is recommended to provide the laser anode with a separate decoupling capacitor C11.

The inverted laser driver modulation pin LAQ is generally not used. To properly balance the output stage, an equalization network Z1 with an impedance comparable to the laser is connected between pin LAQ and  $V_{\text{CC(B)}}$ .

All external components should be SMD, preferably of size 0603 or smaller. The components must be mounted as close to the IC as possible. It is specially recommended to mount the following components very close to the IC:

- Power supply decoupling capacitors C2, C4 and C6
- Input matching network on pins DIN and DINQ
- Capacitor C7 on pin MONIN
- Output matching network Z1 at the unused output.

#### Grounding bare die

In addition to the separate  $V_{\text{CC}}$  domains, the bare die contains three corresponding ground domains. Isolation between the GND domains is limited due to the finite substrate conductance.

Mount the die on a, preferably large and highly conductive, grounded die pad. **All pads GND have to be bonded to the die pad.** The external ground is thus optimally combined with the die ground, avoiding ground bouncing problems.

#### Layout recommendations

Layout recommendations for the TZA3031AHL and TZA3031BHL can be found in application note "AN98090 Fiber optic transceiverboard STM1/4/8, OC3,12,24, FC/GE".

## SDH/SONET STM1/OC3 laser drivers

TZA3031AHL; TZA3031BHL;  
TZA3031U**LIMITING VALUES**

In accordance with the Absolute Maximum Rating System (IEC 134).

SYMBOL	PARAMETER	CONDITIONS	MIN.	MAX.	UNIT
$V_{CC}$	supply voltage		-0.5	+6	V
$V_n$	DC voltage on				
	pin MONIN		1.3	$V_{CC} + 0.5$	V
	pins TONE and TZERO		-0.5	$V_{CC} + 0.5$	V
	pin BGAP		-0.5	+3.2	V
	pin BIAS		-0.5	$V_{CC} + 0.5$	V
	pins LA and LAQ		1.3	$V_{CC} + 0.5$	V
	pin ALS		-0.5	$V_{CC} + 0.5$	V
	pins ONE and ZERO		-0.5	$V_{CC} + 0.5$	V
	pins DIN and DINQ		-0.5	$V_{CC} + 0.5$	V
	pin ALARM	TZA3031AHL	-0.5	$V_{CC} + 0.5$	V
	pins ALARMHI and ALARMLO	TZA3031AHL	-0.5	$V_{CC} + 0.5$	V
	pins DLOOP and DLOOPQ	TZA3031BHL	-0.5	$V_{CC} + 0.5$	V
	pin ENL	TZA3031BHL	-0.5	$V_{CC} + 0.5$	V
$I_n$	DC current on				
	pin MONIN		-0.5	+2.5	mA
	pins TONE and TZERO		-0.5	+0.5	mA
	pin BGAP		-2.0	+2.5	mA
	pin BIAS		-0.5	+200	mA
	pins LA and LAQ		-0.5	+100	mA
	pin ALS		-0.5	+0.5	mA
	pins ONE and ZERO		-0.5	+0.5	mA
	pins DIN and DINQ		-0.5	+0.5	mA
	pin ALARM	TZA3031AHL	-0.5	+10	mA
	pins ALARMHI and ALARMLO	TZA3031AHL	-0.5	+0.5	mA
	pins DLOOP and DLOOPQ	TZA3031BHL	-0.5	+0.5	mA
	pin ENL	TZA3031BHL	-0.5	+0.5	mA
$T_{amb}$	ambient temperature		-40	+85	°C
$T_j$	junction temperature		-40	+125	°C
$T_{stg}$	storage temperature		-65	+150	°C

**THERMAL CHARACTERISTICS**

SYMBOL	PARAMETER	VALUE	UNIT
$R_{th(j-s)}$	thermal resistance from junction to solder point	15	K/W
$R_{th(j-c)}$	thermal resistance from junction to case	23	K/W

## SDH/SONET STM1/OC3 laser drivers

TZA3031AHL; TZA3031BHL;  
TZA3031U

## CHARACTERISTICS

$V_{CC} = 5\text{ V}$ ;  $T_{amb} = -40\text{ to }+85\text{ }^{\circ}\text{C}$ ; all voltages measured with respect to GND.

SYMBOL	PARAMETER	CONDITIONS	MIN.	TYP.	MAX.	UNIT
<b>Supply</b>						
$V_{CC}$	supply voltage		4.75	5	5.25	V
$I_{CC}$	supply current	note 1	–	65	90	mA
$P_{tot}$	total power dissipation	note 2	–	430	810	mW
<b>Data inputs: pins DIN and DINQ (and pins DLOOP and DLOOPQ on TZA3031BHL); see Fig.5</b>						
$V_{i(p-p)}$	input voltage (peak-to-peak value)	differential	100	250	800	mV
$V_{IO}$	input offset voltage		–25	–	+25	mV
$V_{I(min)}$	minimum input voltage		$V_{CC(R)} - 2$	–	–	V
$V_{I(max)}$	maximum input voltage		–	–	$V_{CC(R)} + 0.25$	V
$Z_i$	input impedance	for low frequencies; single-ended	8	10	12	k $\Omega$
<b>CMOS inputs: pin ALS (and pin ENL on TZA3031BHL)</b>						
$V_{IL}$	LOW-level input voltage		–	–	1.5	V
$V_{IH}$	HIGH-level input voltage		3.5	–	–	V
$R_{pd(ALS)}$	internal pull-down resistance on pin ALS		21	25.5	30	k $\Omega$
$R_{pd(ENL)}$	internal pull-down resistance on pin ENL		15	25	35	k $\Omega$
<b>CMOS output: pin ALARM (on TZA3031AHL)</b>						
$V_{OL}$	LOW-level output voltage	$I_{OH} = -200\text{ }\mu\text{A}$	0	–	0.2	V
$V_{OH}$	HIGH-level output voltage	$I_{OH} = 200\text{ }\mu\text{A}$	4.8	–	5	V
<b>Monitor photodiode input: pin MONIN</b>						
$V_I$	DC input voltage		1.5	1.8	2.0	V
$I_{MPD}$	monitor photodiode current	laser optical '0'	24	–	260	$\mu\text{A}$
		laser optical '1'	96	–	1040	$\mu\text{A}$
$C_{MPD}$	monitor photodiode capacitance	note 3	30	–	50	pF
<b>Control loop reference currents: pins ONE and ZERO</b>						
$I_{ref(ONE)}$	reference current on pin ONE	note 4	6	–	65	$\mu\text{A}$
$V_{ref(ONE)}$	reference voltage on pin ONE	referenced to $V_{CC(R)}$	–1.55	–1.5	–1.45	V
$I_{ref(ZERO)}$	reference current on pin ZERO	note 4	6	–	65	$\mu\text{A}$
$V_{ref(ZERO)}$	reference voltage on pin ZERO	referenced to $V_{CC(R)}$	–1.55	–1.5	–1.45	V
<b>Control loop time constants: pins TONE and TZERO</b>						
$V_{TONE}$	voltage on pin TONE	floating output	1.4	–	3.4	V
$g_m(TONE)$	transconductance of pin TONE	note 5	–	100	–	mA/V
$V_{TZERO}$	voltage on pin TZERO	floating output	1.4	–	3.4	V
$g_m(TZERO)$	transconductance of pin TZERO	note 6	–	160	–	mA/V

## SDH/SONET STM1/OC3 laser drivers

TZA3031AHL; TZA3031BHL;  
TZA3031U

SYMBOL	PARAMETER	CONDITIONS	MIN.	TYP.	MAX.	UNIT
<b>Laser modulation outputs: pins LA and LAQ</b>						
$I_O$	modulation output current	note 7	3	–	60	mA
$I_{O(off)}$	output current during laser shutdown		–	–	10	$\mu$ A
$V_O$	output voltage		2	–	5	V
$t_r$	current rise time	note 8	–	120	300	ps
$t_f$	current fall time	note 8	–	120	300	ps
$J_{O(p-p)}$	intrinsic electrical output jitter (peak-to-peak value)	note 9	–	–	50	mUI
<b>Bias current output: pin BIAS</b>						
$I_O$	output current	note 10	2.5	–	90	mA
$I_{O(off)}$	output current during laser shutdown		–	–	10	$\mu$ A
$t_{res(off)}$	response time after laser shutdown	$I_{BIAS} = 90$ mA; note 11	–	–	1	$\mu$ s
$V_O$	output voltage		1	–	5	V
<b>Alarm threshold inputs: pin ALARMHI and ALARMLO (on TZA3031AHL)</b>						
$I_{ref(ALARMLO)}$	threshold reference current on pin ALARMLO	lower alarm; note 12	6	–	65	$\mu$ A
$V_{ref(ALARMLO)}$	optical reference voltage on pin ALARMLO	referenced to $V_{CC(R)}$	–1.55	–1.5	–1.45	V
$I_{ref(ALARMHI)}$	threshold reference current on pin ALARMHI	higher alarm; note 12	6	–	65	$\mu$ A
$V_{ref(ALARMHI)}$	optical reference voltage on pin ALARMHI	referenced to $V_{CC(R)}$	–1.55	–1.5	–1.45	V

**Notes**

- Remarks to the supply current:
  - The value for  $I_{CC}$  does not include the modulation and bias currents through pins LA, LAQ and BIAS.
  - Typical value for  $I_{CC}$  refers to, but does not include,  $I_{MOD} = 30$  mA and  $I_{BIAS} = 45$  mA.
  - The maximum value of  $I_{CC}$  refers to, but does not include,  $I_{MOD} = 60$  mA and  $I_{BIAS} = 90$  mA.
- Remarks to the power dissipation:
  - The value for  $P_{tot}$  includes the modulation and bias currents through pins LA, LAQ and BIAS.
  - The typical value for  $P_{tot}$  is the on-chip dissipation with  $I_{MOD} = 30$  mA and  $V_{LA} = V_{LAQ} = 2$  V,  $I_{BIAS} = 45$  mA and  $V_{BIAS} = 1$  V and typical process parameters.
  - The maximum value for  $P_{tot}$  is the on-chip dissipation with  $I_{MOD} = 60$  mA and  $V_{LA} = V_{LAQ} = 2$  V,  $I_{BIAS} = 90$  mA and  $V_{BIAS} = 1$  V and worst case process parameters.
- The minimum value of the capacitance on pin MONIN is required to prevent instability.
- The reference currents can be set using a resistor connected between pins ONE or ZERO and  $V_{CC}$  (see Section "Automatic laser control"). The corresponding ZERO level MPD current range is from 24 to 260  $\mu$ A. The ONE level MPD current range is from 96 to 1040  $\mu$ A.
- The specified transconductance is the ratio between the modulation current at pins LA or LAQ and the voltage at pin TONE, under small signal conditions.

## SDH/SONET STM1/OC3 laser drivers

TZA3031AHL; TZA3031BHL;  
TZA3031U

6. The specified transconductance is the ratio between the biasing current at pin BIAS and the voltage at pin TZERO, under small signal conditions.
7. The values indicate the guaranteed interval, i.e. the lowest attainable output current is always lower than 3 mA and the highest output current always higher than 60 mA.
8. The voltage rise and fall times can be larger, due to capacitive effects. Specifications are guaranteed by design and characterization. Each device is tested at full operating speed to guarantee the RF functionality.
9. Measured in a frequency band from 250 kHz to 5 MHz, according to "ITU-T Recommendation G.813". The electrically generated (current) jitter is assumed to be less than 50% of the optical output jitter. The specification is guaranteed by design.
10. The values indicate the guaranteed interval, i.e. the lowest output current always is less than 2.5 mA and the highest output current is always more than 90 mA.
11. The response time is defined as the delay between the onset of the ramp on pin ALS (at 10% of the HIGH-level) and the extinction of the bias current (at 10% of the original value).
12. The reference currents can be set by using a resistor between  $V_{CC(R)}$  and pins ALARMLO or ALARMHI; see Section "Bias alarm for TZA3031AHL" for detailed information. The corresponding range of low-bias thresholds is between 1.8 and 19.5 mA. The high-bias threshold range is from 9 to 97.5 mA.

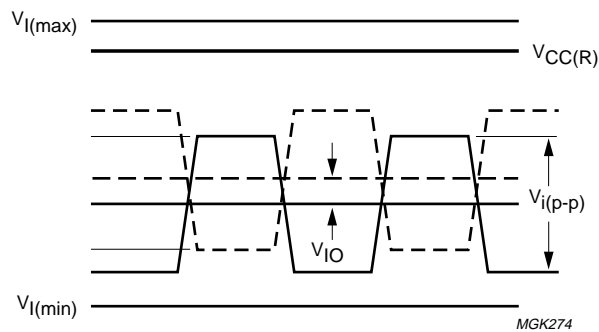
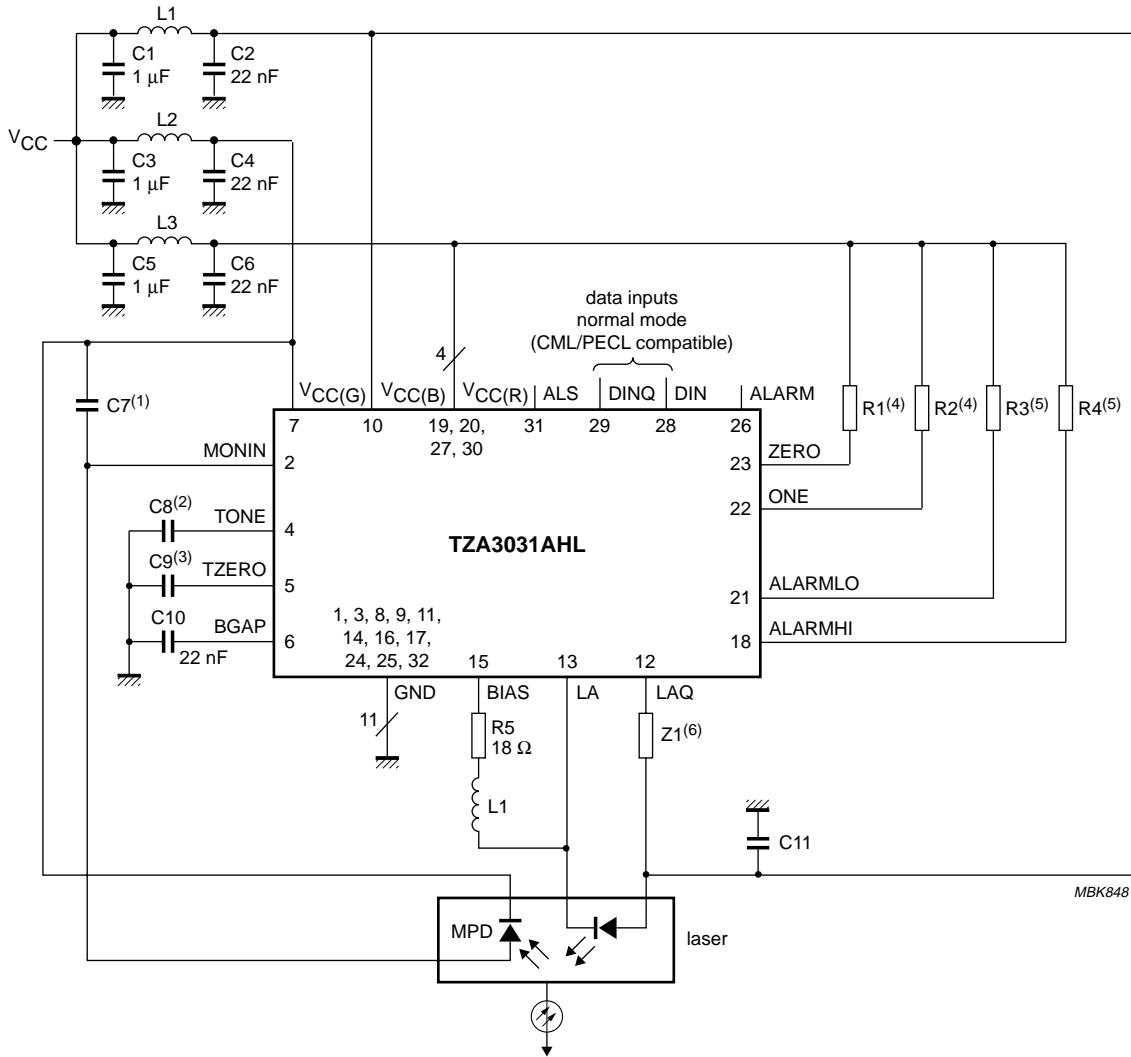

Fig.5 Logic level symbol definitions for data inputs.

SDH/SONET STM1/OC3 laser drivers

TZA3031AHL; TZA3031BHL;  
TZA3031U

APPLICATION INFORMATION



- (1) C7 is required to meet the minimum capacitance value on pin MONIN (optional, see Section "Automatic laser control").
- (2) C8 enhances modulation control loop time constant (optional).
- (3) C9 enhances bias control loop time constant (optional).
- (4) R1 and R2 are used for optical ZERO and ONE reference currents setting (see Section "Automatic laser control").
- (5) R3 and R4 are used for minimum and maximum bias currents setting (see Section "Bias alarm for TZA3031AHL").
- (6) Z1 is required for balancing the output stage (see Section "Power supply connections").

Fig.6 Application diagram showing the TZA3031AHL configured for 155 Mbits/s (STM1/OC3).

SDH/SONET STM1/OC3 laser drivers

TZA3031AHL; TZA3031BHL;  
TZA3031U

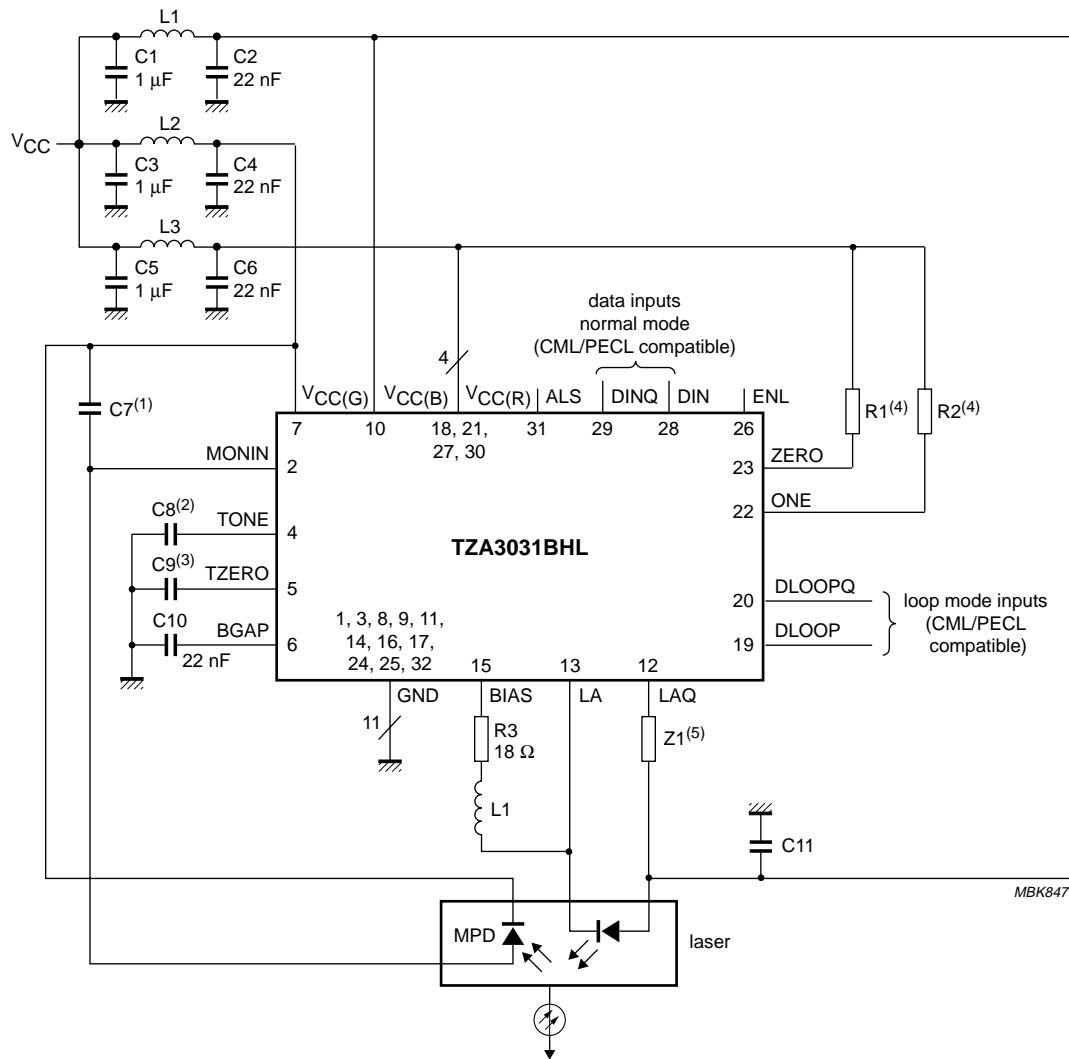

- (1) C7 is required to meet the minimum capacitance value on pin MONIN (optional, see Section "Automatic laser control").
- (2) C8 enhances modulation control loop time constant (optional).
- (3) C9 enhances bias control loop time constant (optional).
- (4) R1 and R2 are used for optical ZERO and ONE reference currents setting (see Section "Automatic laser control").
- (5) Z1 is required for balancing the output stage (see Section "Power supply connections").

Fig.7 Application diagram showing the TZA3031BHL configured for 155 Mbits/s (STM1/OC3).

## SDH/SONET STM1/OC3 laser drivers

TZA3031AHL; TZA3031BHL;  
TZA3031U

## BONDING PADS

SYMBOL	PAD	COORDINATES <sup>(1)</sup>	
		X	Y
GND	1	-664	-910
MONIN	2	-524	-910
GND	3	-367	-910
IGM	4	-227	-910
TONE	5	-70	-910
TZERO	6	+87	-910
BGAP	7	+244	-910
V <sub>CC(G)</sub>	8	+384	-910
V <sub>CC(G)</sub>	9	+524	-910
GND	10	+664	-910
GND	11	+910	-630
V <sub>CC(B)</sub>	12	+910	-490
V <sub>CC(B)</sub>	13	+910	-350
GND	14	+910	-210
LAQ	15	+910	-70
LA	16	+910	+70
GND	17	+910	+210
BIAS	18	+910	+350
GND	19	+910	+490
GND	20	+910	+630
GND	21	+681	+910
ALARMHI	22	+541	+910

SYMBOL	PAD	COORDINATES <sup>(1)</sup>	
		X	Y
V <sub>CC(R)</sub>	23	+384	+910
DLOOP	24	+227	+910
DLOOPQ	25	+87	+910
V <sub>CC(R)</sub>	26	-70	+910
ALARMLO	27	-210	+910
ONE	28	-367	+910
ZERO	29	-524	+910
GND	30	-681	+910
GND	31	-910	+681
ALARM	32	-910	+541
ENL	33	-910	+384
V <sub>CC(R)</sub>	34	-910	+227
DIN	35	-910	+70
DINQ	36	-910	-70
V <sub>CC(R)</sub>	37	-910	-227
ALS	38	-910	-367
GND	39	-910	-551
GND	40	-910	-664

**Note**

1. All x and y coordinates represent the position of the centre of the pad in  $\mu\text{m}$  with respect to the centre of the die (see Fig.8).



SDH/SONET STM1/OC3 laser drivers

TZA3031AHL; TZA3031BHL;  
TZA3031U

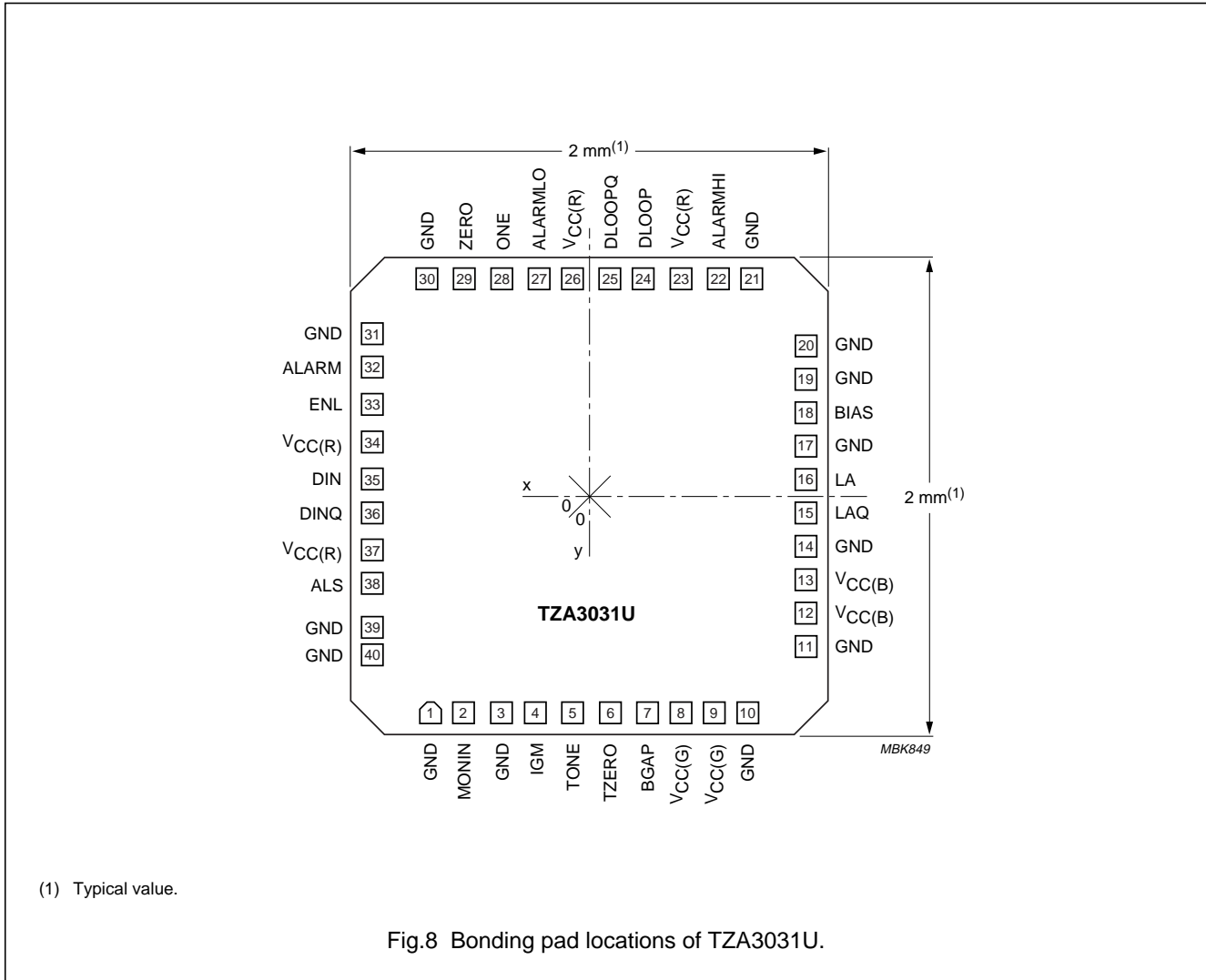

**Table 1** Physical characteristics of bare die

PARAMETER	VALUE
Glass passivation	2.1 μm PSG (PhosphoSilicate Glass) on top of 0.7 μm silicon nitride
Bonding pad dimension	minimum dimension of exposed metallization is 90 × 90 μm (pad size = 100 × 100 μm)
Metallization	1.2 μm AlCu (1% Cu)
Thickness	380 μm nominal
Size	2.000 × 2.000 mm (4.000 mm <sup>2</sup> )
Backing	silicon; electrically connected to GND potential through substrate contacts
Attache temperature	<430 °C; recommended die attache is glue
Attache time	<15 s

SDH/SONET STM1/OC3 laser drivers

TZA3031AHL; TZA3031BHL;  
TZA3031U

PACKAGE OUTLINE

LQFP32: plastic low profile quad flat package; 32 leads; body 5 x 5 x 1.4 mm

SOT401-1

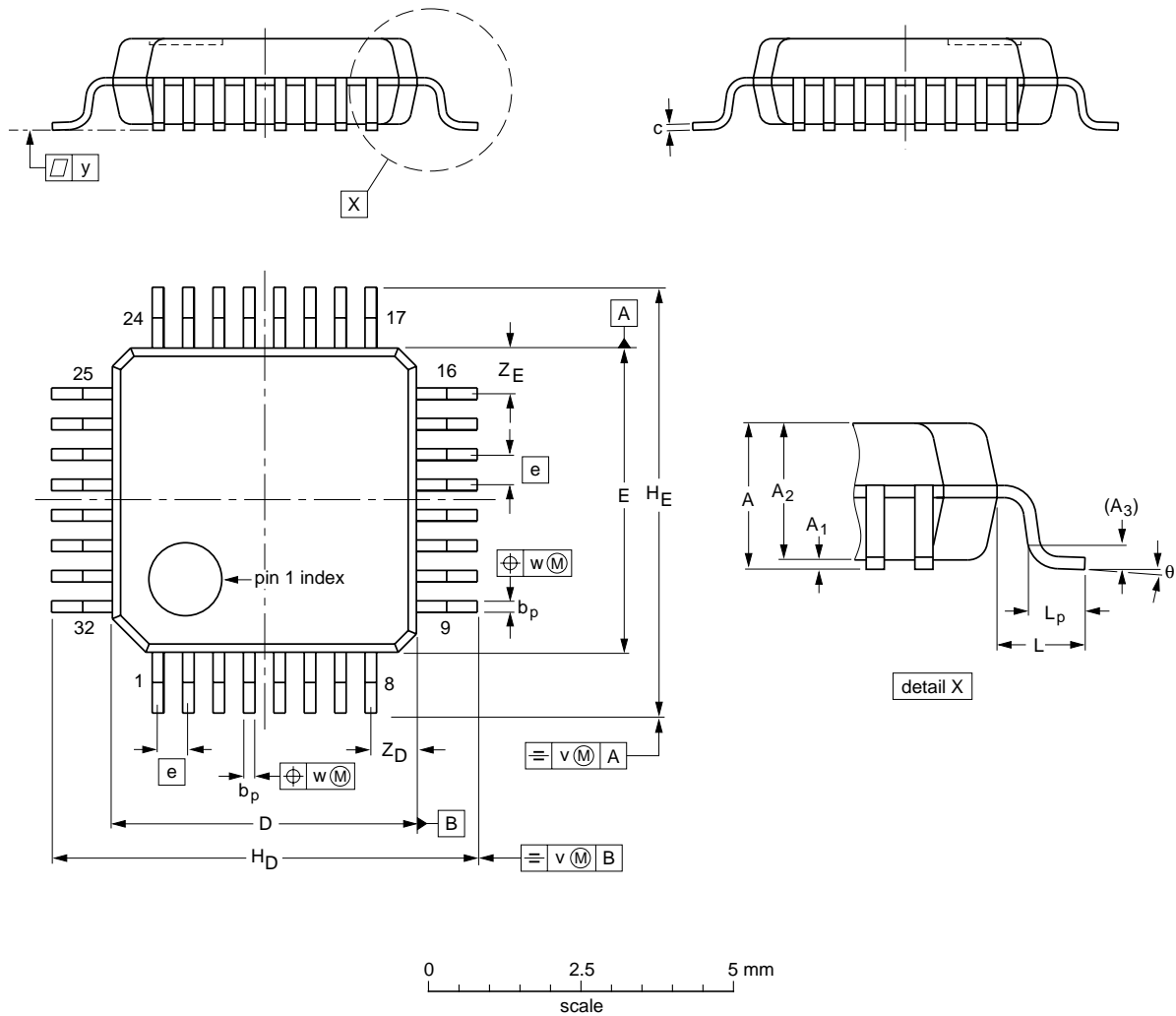

DIMENSIONS (mm are the original dimensions)

UNIT	A max.	A <sub>1</sub>	A <sub>2</sub>	A <sub>3</sub>	b <sub>p</sub>	c	D <sup>(1)</sup>	E <sup>(1)</sup>	e	H <sub>D</sub>	H <sub>E</sub>	L	L <sub>p</sub>	v	w	y	Z <sub>D</sub> <sup>(1)</sup>	Z <sub>E</sub> <sup>(1)</sup>	θ
mm	1.60	0.15 0.05	1.5 1.3	0.25	0.27 0.17	0.18 0.12	5.1 4.9	5.1 4.9	0.5	7.15 6.85	7.15 6.85	1.0	0.75 0.45	0.2	0.12	0.1	0.95 0.55	0.95 0.55	7° 0°

Note

1. Plastic or metal protrusions of 0.25 mm maximum per side are not included.

OUTLINE VERSION	REFERENCES				EUROPEAN PROJECTION	ISSUE DATE
	IEC	JEDEC	EIAJ			
SOT401-1						95-12-19 97-08-04

## SDH/SONET STM1/OC3 laser drivers

TZA3031AHL; TZA3031BHL;  
TZA3031U**SOLDERING****Introduction to soldering surface mount packages**

This text gives a very brief insight to a complex technology. A more in-depth account of soldering ICs can be found in our *"Data Handbook IC26; Integrated Circuit Packages"* (document order number 9398 652 90011).

There is no soldering method that is ideal for all surface mount IC packages. Wave soldering is not always suitable for surface mount ICs, or for printed-circuit boards with high population densities. In these situations reflow soldering is often used.

**Reflow soldering**

Reflow soldering requires solder paste (a suspension of fine solder particles, flux and binding agent) to be applied to the printed-circuit board by screen printing, stencilling or pressure-syringe dispensing before package placement.

Several methods exist for reflowing; for example, infrared/convection heating in a conveyor type oven. Throughput times (preheating, soldering and cooling) vary between 100 and 200 seconds depending on heating method.

Typical reflow peak temperatures range from 215 to 250 °C. The top-surface temperature of the packages should preferably be kept below 230 °C.

**Wave soldering**

Conventional single wave soldering is not recommended for surface mount devices ( ) or printed-circuit boards with a high component density, as solder bridging and non-wetting can present major problems.

To overcome these problems the double-wave soldering method was specifically developed.

If wave soldering is used the following conditions must be observed for optimal results:

- Use a double-wave soldering method comprising a turbulent wave with high upward pressure followed by a smooth laminar wave.
- For packages with leads on two sides and a pitch (e):
  - larger than or equal to 1.27 mm, the footprint longitudinal axis is **preferred** to be parallel to the transport direction of the printed-circuit board;
  - smaller than 1.27 mm, the footprint longitudinal axis **must** be parallel to the transport direction of the printed-circuit board.

The footprint must incorporate solder thieves at the downstream end.

- For packages with leads on four sides, the footprint must be placed at a 45° angle to the transport direction of the printed-circuit board. The footprint must incorporate solder thieves downstream and at the side corners.

During placement and before soldering, the package must be fixed with a droplet of adhesive. The adhesive can be applied by screen printing, pin transfer or syringe dispensing. The package can be soldered after the adhesive is cured.

Typical dwell time is 4 seconds at 250 °C.

A mildly-activated flux will eliminate the need for removal of corrosive residues in most applications.

**Manual soldering**

Fix the component by first soldering two diagonally-opposite end leads. Use a low voltage (24 V or less) soldering iron applied to the flat part of the lead. Contact time must be limited to 10 seconds at up to 300 °C.

When using a dedicated tool, all other leads can be soldered in one operation within 2 to 5 seconds between 270 and 320 °C.

SDH/SONET STM1/OC3 laser drivers

TZA3031AHL; TZA3031BHL;  
TZA3031U

Suitability of surface mount IC packages for wave and reflow soldering methods

PACKAGE	SOLDERING METHOD	
	WAVE	REFLOW <sup>(1)</sup>
BGA, SQFP	not suitable	suitable
HLQFP, HSQFP, HSOP, HTSSOP, SMS	not suitable <sup>(2)</sup>	suitable
PLCC <sup>(3)</sup> , SO, SOJ	suitable	suitable
LQFP, QFP, TQFP	not recommended <sup>(3)(4)</sup>	suitable
SSOP, TSSOP, VSO	not recommended <sup>(5)</sup>	suitable

Notes

1. All surface mount (SMD) packages are moisture sensitive. Depending upon the moisture content, the maximum temperature (with respect to time) and body size of the package, there is a risk that internal or external package cracks may occur due to vaporization of the moisture in them (the so called popcorn effect). For details, refer to the Drypack information in the *"Data Handbook IC26; Integrated Circuit Packages; Section: Packing Methods"*.
2. These packages are not suitable for wave soldering as a solder joint between the printed-circuit board and heatsink (at bottom version) can not be achieved, and as solder may stick to the heatsink (on top version).
3. If wave soldering is considered, then the package must be placed at a 45° angle to the solder wave direction. The package footprint must incorporate solder thieves downstream and at the side corners.
4. Wave soldering is only suitable for LQFP, TQFP and QFP packages with a pitch (e) equal to or larger than 0.8 mm; it is definitely not suitable for packages with a pitch (e) equal to or smaller than 0.65 mm.
5. Wave soldering is only suitable for SSOP and TSSOP packages with a pitch (e) equal to or larger than 0.65 mm; it is definitely not suitable for packages with a pitch (e) equal to or smaller than 0.5 mm.

## SDH/SONET STM1/OC3 laser drivers

TZA3031AHL; TZA3031BHL;  
TZA3031U**DEFINITIONS**

<b>Data sheet status</b>	
Objective specification	This data sheet contains target or goal specifications for product development.
Preliminary specification	This data sheet contains preliminary data; supplementary data may be published later.
Product specification	This data sheet contains final product specifications.
<b>Limiting values</b>	
Limiting values given are in accordance with the Absolute Maximum Rating System (IEC 134). Stress above one or more of the limiting values may cause permanent damage to the device. These are stress ratings only and operation of the device at these or at any other conditions above those given in the Characteristics sections of the specification is not implied. Exposure to limiting values for extended periods may affect device reliability.	
<b>Application information</b>	
Where application information is given, it is advisory and does not form part of the specification.	

**LIFE SUPPORT APPLICATIONS**

These products are not designed for use in life support appliances, devices, or systems where malfunction of these products can reasonably be expected to result in personal injury. Philips customers using or selling these products for use in such applications do so at their own risk and agree to fully indemnify Philips for any damages resulting from such improper use or sale.

**BARE DIE DISCLAIMER**

All die are tested and are guaranteed to comply with all data sheet limits up to the point of wafer sawing for a period of ninety (90) days from the date of Philips' delivery. If there are data sheet limits not guaranteed, these will be separately indicated in the data sheet. There is no post wafer pack testing performed on individual die. Although the most modern processes are utilized for wafer sawing and die pick and place into wafer pack carriers, Philips Semiconductors has no control of third party procedures in the handling, packing or assembly of the die. Accordingly, Philips Semiconductors assumes no liability for device functionality or performance of the die or systems after handling, packing or assembly of the die. It is the responsibility of the customer to test and qualify their application in which the die is used.

---

SDH/SONET STM1/OC3 laser drivers

TZA3031AHL; TZA3031BHL;  
TZA3031U

---

**NOTES**

---

SDH/SONET STM1/OC3 laser drivers

TZA3031AHL; TZA3031BHL;  
TZA3031U

---

**NOTES**

# Philips Semiconductors – a worldwide company

**Argentina:** see South America

**Australia:** 3 Figtree Drive, HOMEBUSH, NSW 2140,  
Tel. +61 2 9704 8141, Fax. +61 2 9704 8139

**Austria:** Computerstr. 6, A-1101 WIEN, P.O. Box 213,  
Tel. +43 1 60 101 1248, Fax. +43 1 60 101 1210

**Belarus:** Hotel Minsk Business Center, Bld. 3, r. 1211, Volodarski Str. 6,  
220050 MINSK, Tel. +375 172 20 0733, Fax. +375 172 20 0773

**Belgium:** see The Netherlands

**Brazil:** see South America

**Bulgaria:** Philips Bulgaria Ltd., Energoproject, 15th floor,  
51 James Bourchier Blvd., 1407 SOFIA,  
Tel. +359 2 68 9211, Fax. +359 2 68 9102

**Canada:** PHILIPS SEMICONDUCTORS/COMPONENTS,  
Tel. +1 800 234 7381, Fax. +1 800 943 0087

**China/Hong Kong:** 501 Hong Kong Industrial Technology Centre,  
72 Tat Chee Avenue, Kowloon Tong, HONG KONG,  
Tel. +852 2319 7888, Fax. +852 2319 7700

**Colombia:** see South America

**Czech Republic:** see Austria

**Denmark:** Sydhavnsgade 23, 1780 COPENHAGEN V,  
Tel. +45 33 29 3333, Fax. +45 33 29 3905

**Finland:** Sinikalliontie 3, FIN-02630 ESPOO,  
Tel. +358 9 615 800, Fax. +358 9 6158 0920

**France:** 51 Rue Carnot, BP317, 92156 SURESNES Cedex,  
Tel. +33 1 4099 6161, Fax. +33 1 4099 6427

**Germany:** Hammerbrookstraße 69, D-20097 HAMBURG,  
Tel. +49 40 2353 60, Fax. +49 40 2353 6300

**Hungary:** see Austria

**India:** Philips INDIA Ltd, Band Box Building, 2nd floor,  
254-D, Dr. Annie Besant Road, Worli, MUMBAI 400 025,  
Tel. +91 22 493 8541, Fax. +91 22 493 0966

**Indonesia:** PT Philips Development Corporation, Semiconductors Division,  
Gedung Philips, Jl. Buncit Raya Kav.99-100, JAKARTA 12510,  
Tel. +62 21 794 0040 ext. 2501, Fax. +62 21 794 0080

**Ireland:** Newstead, Clonskeagh, DUBLIN 14,  
Tel. +353 1 7640 000, Fax. +353 1 7640 200

**Israel:** RAPAC Electronics, 7 Kehilat Saloniki St, PO Box 18053,  
TEL AVIV 61180, Tel. +972 3 645 0444, Fax. +972 3 649 1007

**Italy:** PHILIPS SEMICONDUCTORS, Via Casati, 23 - 20052 MONZA (MI),  
Tel. +39 039 203 6838, Fax +39 039 203 6800

**Japan:** Philips Bldg 13-37, Kohnan 2-chome, Minato-ku,  
TOKYO 108-8507, Tel. +81 3 3740 5130, Fax. +81 3 3740 5057

**Korea:** Philips House, 260-199 Itaewon-dong, Yongsan-ku, SEOUL,  
Tel. +82 2 709 1412, Fax. +82 2 709 1415

**Malaysia:** No. 76 Jalan Universiti, 46200 PETALING JAYA, SELANGOR,  
Tel. +60 3 750 5214, Fax. +60 3 757 4880

**Mexico:** 5900 Gateway East, Suite 200, EL PASO, TEXAS 79905,  
Tel. +9-5 800 234 7381, Fax +9-5 800 943 0087

**Middle East:** see Italy

**Netherlands:** Postbus 90050, 5600 PB EINDHOVEN, Bldg. VB,  
Tel. +31 40 27 82785, Fax. +31 40 27 88399

**New Zealand:** 2 Wagener Place, C.P.O. Box 1041, AUCKLAND,  
Tel. +64 9 849 4160, Fax. +64 9 849 7811

**Norway:** Box 1, Manglerud 0612, OSLO,  
Tel. +47 22 74 8000, Fax. +47 22 74 8341

**Pakistan:** see Singapore

**Philippines:** Philips Semiconductors Philippines Inc.,  
106 Valero St. Salcedo Village, P.O. Box 2108 MCC, MAKATI,  
Metro MANILA, Tel. +63 2 816 6380, Fax. +63 2 817 3474

**Poland:** Ul. Lukiska 10, PL 04-123 WARSZAWA,  
Tel. +48 22 612 2831, Fax. +48 22 612 2327

**Portugal:** see Spain

**Romania:** see Italy

**Russia:** Philips Russia, Ul. Usatcheva 35A, 119048 MOSCOW,  
Tel. +7 095 755 6918, Fax. +7 095 755 6919

**Singapore:** Lorong 1, Toa Payoh, SINGAPORE 319762,  
Tel. +65 350 2538, Fax. +65 251 6500

**Slovakia:** see Austria

**Slovenia:** see Italy

**South Africa:** S.A. PHILIPS Pty Ltd., 195-215 Main Road Martindale,  
2092 JOHANNESBURG, P.O. Box 58088 Newville 2114,  
Tel. +27 11 471 5401, Fax. +27 11 471 5398

**South America:** Al. Vicente Pinzon, 173, 6th floor,  
04547-130 SÃO PAULO, SP, Brazil,  
Tel. +55 11 821 2333, Fax. +55 11 821 2382

**Spain:** Balmes 22, 08007 BARCELONA,  
Tel. +34 93 301 6312, Fax. +34 93 301 4107

**Sweden:** Kottbygatan 7, Akalla, S-16485 STOCKHOLM,  
Tel. +46 8 5985 2000, Fax. +46 8 5985 2745

**Switzerland:** Allmendstrasse 140, CH-8027 ZÜRICH,  
Tel. +41 1 488 2741 Fax. +41 1 488 3263

**Taiwan:** Philips Semiconductors, 6F, No. 96, Chien Kuo N. Rd., Sec. 1,  
TAIPEI, Taiwan Tel. +886 2 2134 2886, Fax. +886 2 2134 2874

**Thailand:** PHILIPS ELECTRONICS (THAILAND) Ltd.,  
209/2 Sanpavuth-Bangna Road Prakanong, BANGKOK 10260,  
Tel. +66 2 745 4090, Fax. +66 2 398 0793

**Turkey:** Yukari Dudullu, Org. San. Blg., 2.Cad. Nr. 28 81260 Umraniye,  
ISTANBUL, Tel. +90 216 522 1500, Fax. +90 216 522 1813

**Ukraine:** PHILIPS UKRAINE, 4 Patrice Lumumba str., Building B, Floor 7,  
252042 KIEV, Tel. +380 44 264 2776, Fax. +380 44 268 0461

**United Kingdom:** Philips Semiconductors Ltd., 276 Bath Road, Hayes,  
MIDDLESEX UB3 5BX, Tel. +44 208 730 5000, Fax. +44 208 754 8421

**United States:** 811 East Arques Avenue, SUNNYVALE, CA 94088-3409,  
Tel. +1 800 234 7381, Fax. +1 800 943 0087

**Uruguay:** see South America

**Vietnam:** see Singapore

**Yugoslavia:** PHILIPS, Trg N. Pasica 5/v, 11000 BEOGRAD,  
Tel. +381 11 62 5344, Fax.+381 11 63 5777

**For all other countries apply to:** Philips Semiconductors,  
International Marketing & Sales Communications, Building BE-p, P.O. Box 218,  
5600 MD EINDHOVEN, The Netherlands, Fax. +31 40 27 24825

**Internet:** <http://www.semiconductors.philips.com>

© Philips Electronics N.V. 1999

SCA 67

All rights are reserved. Reproduction in whole or in part is prohibited without the prior written consent of the copyright owner.

The information presented in this document does not form part of any quotation or contract, is believed to be accurate and reliable and may be changed without notice. No liability will be accepted by the publisher for any consequence of its use. Publication thereof does not convey nor imply any license under patent- or other industrial or intellectual property rights.

Printed in The Netherlands

465012/02/pp24

Date of release: 1999 Aug 24

Document order number: 9397 750 05283

*Let's make things better.*

**Philips**  
Semiconductors



**PHILIPS**



SUNSTAR 商斯达实业集团是集研发、生产、工程、销售、代理经销、技术咨询、信息服务等为一体的高科技企业，是专业高科技电子产品生产厂家，是具有 10 多年历史的专业电子元器件供应商，是中国最早和最大的仓储式连锁规模经营大型综合电子零部件代理分销商之一，是一家专业代理和分销世界各大品牌 IC 芯片和电子元器件的连锁经营综合性国际公司，专业经营进口、国产名厂名牌电子元件，型号、种类齐全。在香港、北京、深圳、上海、西安、成都等全国主要电子市场设有直属分公司和产品展示展销窗口门市部专卖店及代理分销商，已在全国范围内建成强大统一的供货和代理分销网络。我们专业代理经销、开发生产电子元器件、集成电路、传感器、微波光电元器件、工控机/DOC/DOM 电子盘、专用电路、单片机开发、MCU/DSP/ARM/FPGA 软件硬件、二极管、三极管、模块等，是您可靠的一站式现货配套供应商、方案提供商、部件功能模块开发配套商。商斯达实业公司拥有庞大的资料库，有数位毕业于著名高校——有中国电子工业摇篮之称的西安电子科技大学（西军电）并长期从事国防尖端科技研究的高级工程师为您精挑细选、量身订做各种高科技电子元器件，并解决各种技术问题。

微波光电部专业代理经销高频、微波、光纤、光电元器件、组件、部件、模块、整机；电磁兼容元器件、材料、设备；微波 CAD、EDA 软件、开发测试仿真工具；微波、光纤仪器仪表。欢迎国外高科技微波、光纤厂商将优秀产品介绍到中国、共同开拓市场。长期大量现货专业批发高频、微波、卫星、光纤、电视、CATV 器件：晶振、VCO、连接器、PIN 开关、变容二极管、开关二极管、低噪晶体管、功率电阻及电容、放大器、功率管、MMIC、混频器、耦合器、功分器、振荡器、合成器、衰减器、滤波器、隔离器、环行器、移相器、调制解调器；光电子元件和组件：红外发射管、红外接收管、光电开关、光敏管、发光二极管和发光二极管组件、半导体激光二极管和激光器组件、光电探测器和光接收组件、光发射接收模块、光纤激光器和光放大器、光调制器、光开关、DWDM 用光发射和接收器件、用户接入系统光收发器件与模块、光纤连接器、光纤跳线/尾纤、光衰减器、光纤适配器、光隔离器、光耦合器、光环行器、光复用器/转换器；无线收发芯片和模组、蓝牙芯片和模组。

更多产品请看本公司产品专用销售网站：

商斯达中国传感器科技信息网：<http://www.sensor-ic.com/>

商斯达工控安防网：<http://www.pc-ps.net/>

商斯达电子元器件网：<http://www.sunstare.com/>

商斯达微波光电产品网：[HTTP://www.rfoe.net/](http://www.rfoe.net/)

商斯达消费电子产品网：<http://www.icasic.com/>

商斯达实业科技产品网：<http://www.sunstars.cn/> 微波元器件销售热线：

地址：深圳市福田区福华路福庆街鸿图大厦 1602 室

电话：0755-82884100 83397033 83396822 83398585

传真：0755-83376182 (0) 13823648918 MSN: SUNS8888@hotmail.com

邮编：518033 E-mail:[szss20@163.com](mailto:szss20@163.com) QQ: 195847376

深圳赛格展销部：深圳华强北路赛格电子市场 2583 号 电话：0755-83665529 25059422

技术支持：0755-83394033 13501568376

欢迎索取免费详细资料、设计指南和光盘；产品凡多，未能尽录，欢迎来电查询。

北京分公司：北京海淀区知春路 132 号中发电子大厦 3097 号

TEL: 010-81159046 82615020 13501189838 FAX: 010-62543996

上海分公司：上海市北京东路 668 号上海赛格电子市场 D125 号

TEL: 021-28311762 56703037 13701955389 FAX: 021-56703037

西安分公司：西安高新开发区 20 所(中国电子科技集团导航技术研究所)

西安劳动南路 88 号电子商城二楼 D23 号

TEL: 029-81022619 13072977981 FAX:029-88789382