

DATA SHEET

UAA2077CM 2 GHz image rejecting front-end

Product specification
Supersedes data of 1996 Oct 02
File under Integrated Circuits, IC17

1997 Sep 24

2 GHz image rejecting front-end**UAA2077CM****FEATURES**

- Low-noise, wide dynamic range amplifier
- Very low noise figure
- Dual balanced mixer for over 30 dB on-chip image rejection
- IF I/Q combiner at 188 MHz
- On-chip quadrature network
- Down-conversion mixer for closed-loop transmitters
- Independent TX/RX fast ON/OFF power-down modes
- Very small outline packaging
- Very small application (no image filter).

APPLICATIONS

- High frequency front-end for DCS1800/PCS1900 hand-portable equipment
- Compact digital mobile communication equipment
- TDMA receivers e.g. RF-LANS.

GENERAL DESCRIPTION

UAA2077CM contains both a receiver front-end and a high frequency transmit mixer intended to be used in mobile telephones. Designed in an advanced BiCMOS process it combines high performance with low power consumption and a high degree of integration, thus reducing external component costs and total front-end size.

The main advantage of the UAA2077CM is its ability to provide over 30 dB of image rejection. Consequently, the image filter between the LNA and the mixer is suppressed.

Image rejection is achieved in the internal architecture by two RF mixers in quadrature and two all-pass filters in I and Q IF channels that phase shift the IF by 45° and 135° respectively. The two phase shifted IFs are recombined and buffered to furnish the IF output signal.

Signals presented at the RF input at LO + IF frequency are rejected through this signal processing while signals at LO – IF frequency can form the IF signal.

The receiver section consists of a low-noise amplifier that drives a quadrature mixer pair. The IF amplifier has on-chip 45° and 135° phase shifting and a combining network for image rejection. The IF driver has differential open-collector type outputs.

The LO part consists of an internal all-pass type phase shifter to provide quadrature LO signals to the receive mixers. The all-pass filters outputs are buffered before being fed to the receive mixers.

The transmit section consists of a low-noise amplifier, and a down-conversion mixer. In the transmit mode, an internal LO buffer is used to drive the transmit IF down-conversion mixer.

All RF and IF inputs or outputs are balanced.

Pins RXON, TXON and SXON allow to control the different power-down modes. A synthesizer-on (SX) mode enables LO buffers independent of the other circuits. When pin SXON is HIGH, all internal buffers on the LO path of the circuit are turned on, thus minimizing LO pulling when remainder of the receive or transmit chain is powered up. Special care has been taken for fast power-up switching.

QUICK REFERENCE DATA

SYMBOL	PARAMETER	MIN.	TYP.	MAX.	UNIT
V _{CC}	supply voltage	3.6	3.75	5.3	V
I _{CC(RX)}	receive supply current	27.5	36	44.5	mA
I _{CC(TX)}	transmit supply current	11	14	17.5	mA
I _{CC(PD)}	supply current in power-down	–	–	50	μA
T _{amb}	operating ambient temperature	–30	+25	+75	°C

2 GHz image rejecting front-end

UAA2077CM

ORDERING INFORMATION

TYPE NUMBER	PACKAGE		
	NAME	DESCRIPTION	VERSION
UAA2077CM	SSOP20	plastic shrink small outline package; 20 leads; body width 4.4 mm	SOT266-1

BLOCK DIAGRAM

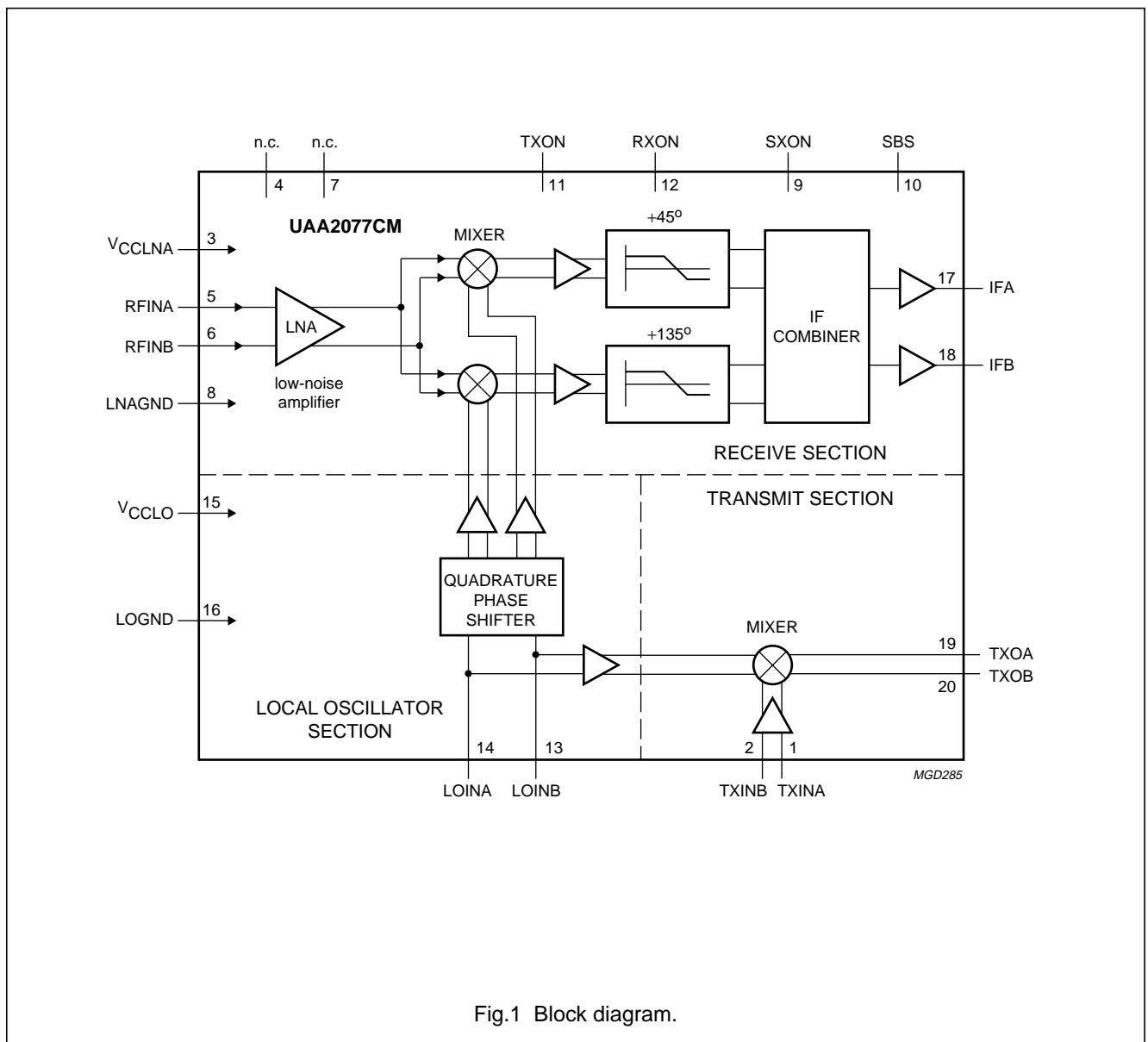

Fig.1 Block diagram.

2 GHz image rejecting front-end

UAA2077CM

PINNING

SYMBOL	PIN	DESCRIPTION
TXINA	1	transmit mixer input A (balanced)
TXINB	2	transmit mixer input B (balanced)
V _{CCLNA}	3	supply voltage for LNA, IF parts and TX mixer
n.c.	4	not connected
RFINA	5	RF input A (balanced)
RFINB	6	RF input B (balanced)
n.c.	7	not connected
LNAGND	8	ground for LNA, IF parts and TX mixer
SXON	9	SX mode enable (see Table 1)
SBS	10	sideband selection (should be grounded for $f_{LO} < f_{RF}$)
TXON	11	TX mode enable (see Table 1)
RXON	12	RX mode enable (see Table 1)
LOINB	13	LO input B (balanced)
LOINA	14	LO input A (balanced)
V _{CCLLO}	15	supply voltage for LO parts
LOGND	16	ground for LO parts
IFA	17	IF output A (balanced)
IFB	18	IF output B (balanced)
TXOA	19	transmit mixer IF output A (balanced)
TXOB	20	transmit mixer IF output B (balanced)

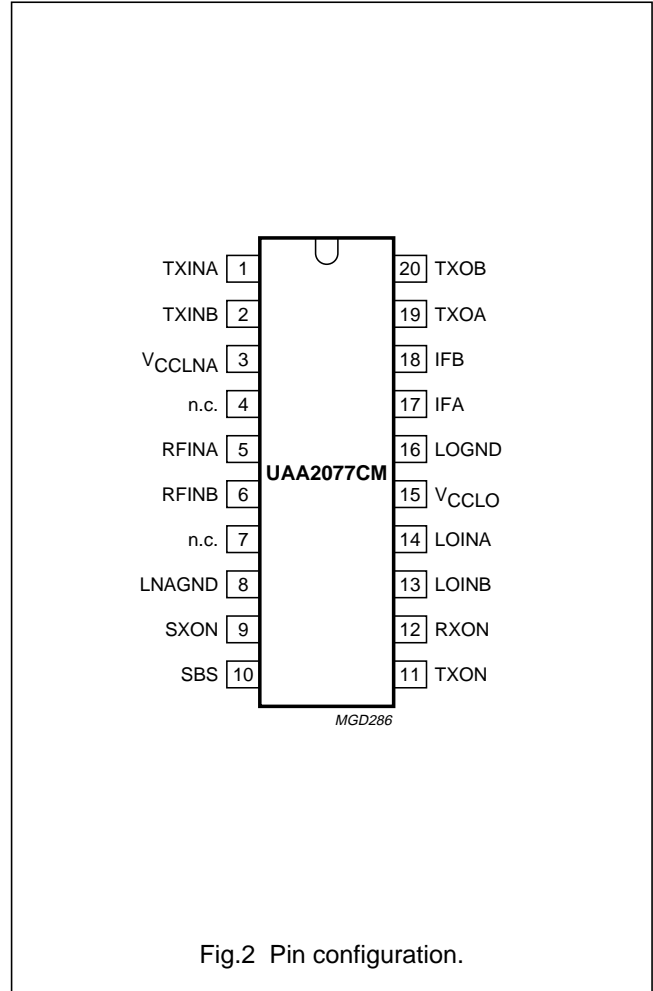

Fig.2 Pin configuration.

2 GHz image rejecting front-end

UAA2077CM

FUNCTIONAL DESCRIPTION

Receive section

The circuit contains a low-noise amplifier followed by two high dynamic range mixers. These mixers are of the Gilbert-cell type, the whole internal architecture is fully differential.

The local oscillator, shifted in phase to 45° and 135°, mixes the amplified RF to create I and Q channels. The two I and Q channels are buffered, phase shifted by 45° and 135° respectively, amplified and recombined internally to realize the image rejection.

Pin SBS allows sideband selection:

- $f_{LO} > f_{RF}$ (SBS = 1)
- $f_{LO} < f_{RF}$ (SBS = 0).

Where f_{RF} is the frequency of the wanted signal.

Balanced signal interfaces are used for minimizing crosstalk due to package parasitics.

The IF output is differential and of the open-collector type. Typical application will load the output with a 680 Ω resistor load at each IF output, plus a differential 1 kΩ load made of the input impedance of the IF filter or the input impedance of the matching network for the IF filter.

The power gain refers to the available power on this 1 kΩ load. The path to V_{CC} for the DC current should be achieved via tuning inductors. The output voltage is limited to $V_{CC} + 3V_{be}$ or 3 diode forward voltage drops.

Fast switching, ON/OFF, of the receive section is controlled by the hardware input RXON.

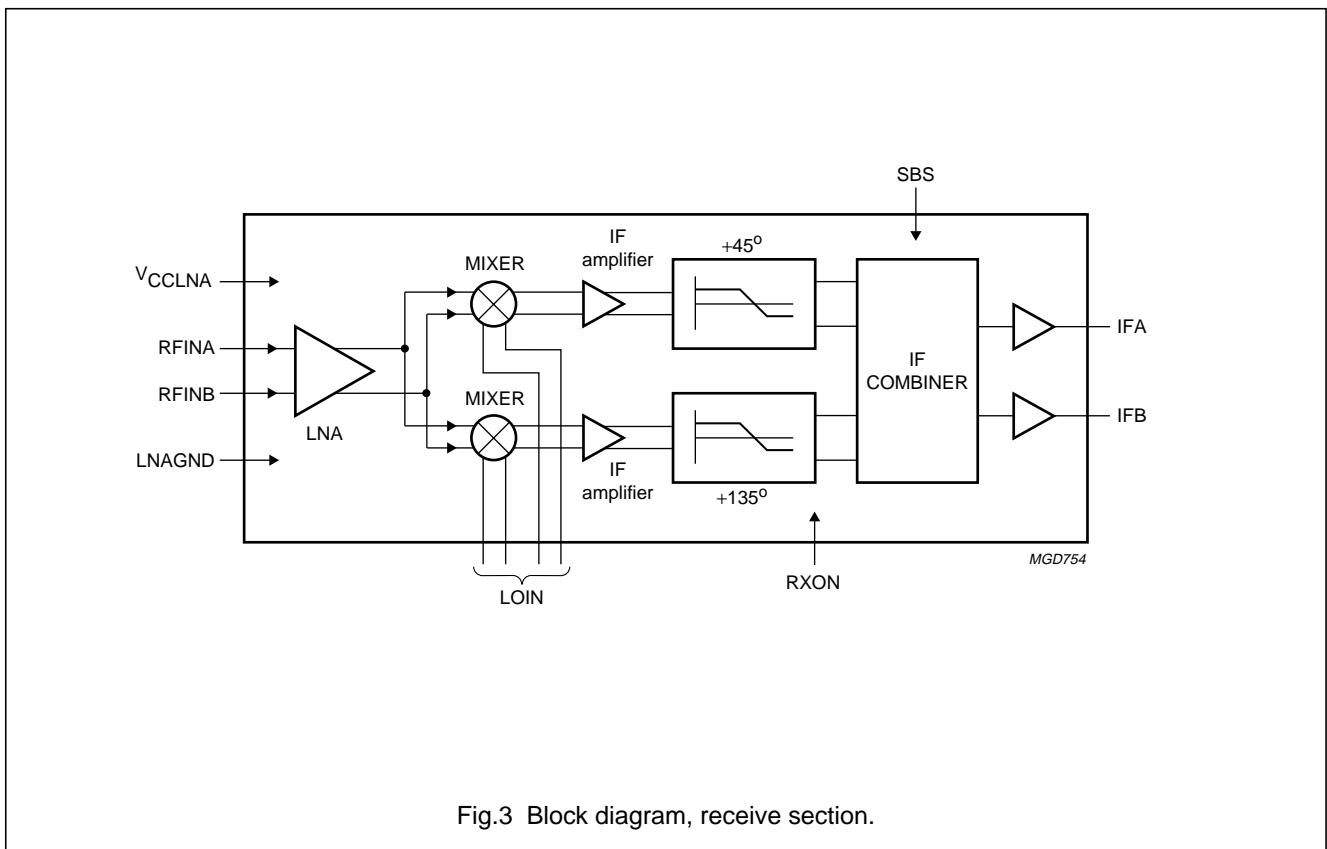

Fig.3 Block diagram, receive section.

2 GHz image rejecting front-end

UAA2077CM

Local oscillator section

The Local Oscillator (LO) input directly drives the two internal all-pass networks to provide quadrature LO to the receive mixers.

A synthesizer-ON mode (SX mode) is used to power-up all LO input buffers, thus minimizing the pulling effect on the external VCO when entering receive or transmit mode. This mode is active when SXON = 1.

Transmit mixer

This mixer is used for down-conversion to the transmit IF. Its inputs are coupled to the transmit RF which is

down-converted to a modulated transmit IF frequency, phase locked with the baseband modulation.

The IF outputs are HIGH impedance (open-collector type). Typical application will load the output with a 560 Ω resistor load, connected to V_{CC} for DC path, at each TX output, plus a differential 1 kΩ made of the input impedance of the matching network for the following TX part. The mixer can also be used for frequency up-conversion.

Fast switching, ON/OFF, of the transmit section is controlled by the hardware input TXON.

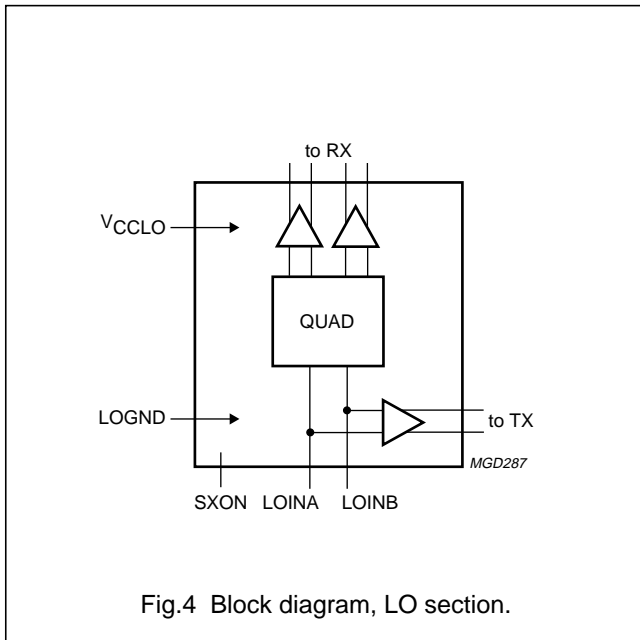

Fig.4 Block diagram, LO section.

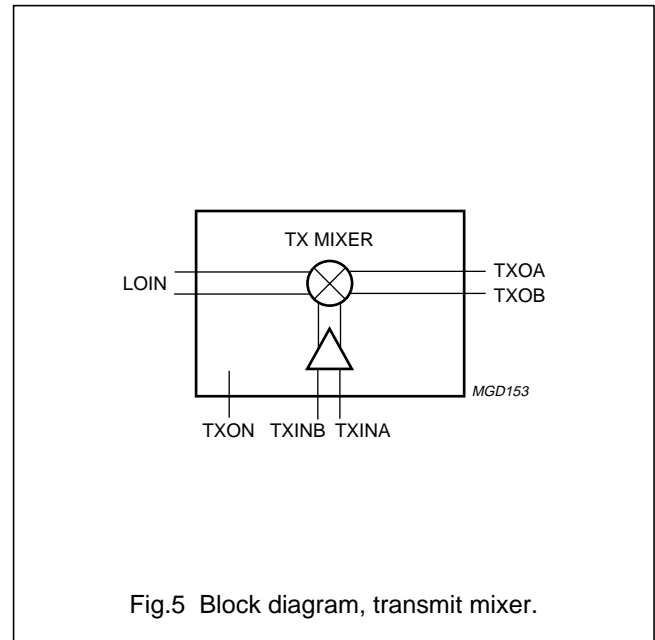

Fig.5 Block diagram, transmit mixer.

Table 1 Control of power status

EXTERNAL PIN LEVEL			CIRCUIT MODE OF OPERATION
TXON	RXON	SXON	
LOW	LOW	LOW	power-down mode
LOW	HIGH	LOW	RX mode: receive section and LO buffers to RX on
HIGH	LOW	LOW	TX mode: transmit section and LO buffers to TX on
LOW	LOW	HIGH	SX mode: complete LO section on
LOW	HIGH	HIGH	SRX mode: receive section on and SX mode active
HIGH	LOW	HIGH	STX mode: transmit section on and SX mode active
HIGH	HIGH	X	receive section and transmit section on; specification not guaranteed

2 GHz image rejecting front-end

UAA2077CM

LIMITING VALUES

In accordance with the Absolute Maximum Rating System (IEC 134).

SYMBOL	PARAMETER	MIN.	MAX.	UNIT
V_{CC}	supply voltage	–	9	V
ΔGND	difference in ground supply voltage applied between LOGND and LNAGND	–	0.6	V
$P_{i(max)}$	maximum power input	–	+20	dBm
$T_{j(max)}$	maximum operating junction temperature	–	+150	°C
$P_{dis(max)}$	maximum power dissipation in quiet air	–	250	mW
T_{stg}	storage temperature	–65	+150	°C

THERMAL CHARACTERISTICS

SYMBOL	PARAMETER	VALUE	UNIT
$R_{th\ j-a}$	thermal resistance from junction to ambient in free air	120	K/W

HANDLING

All pins withstand 1500 V ESD test in accordance with "MIL-STD-883C class 1 (method 3015.5)".

2 GHz image rejecting front-end

UAA2077CM

DC CHARACTERISTICS

$V_{CC} = 3.75\text{ V}$; $T_{amb} = 25\text{ °C}$; unless otherwise specified.

SYMBOL	PARAMETER	CONDITIONS	MIN.	TYP.	MAX.	UNIT
Pins: V_{CCLNA} and V_{CCLO}						
V_{CC}	supply voltage	over full temperature range	3.6	3.75	5.3	V
$I_{CC(RX)}$	supply current in RX mode		27.5	36	44.5	mA
$I_{CC(TX)}$	supply current in TX mode		11	14	17.5	mA
$I_{CC(PD)}$	supply current in power-down mode		–	–	50	μA
$I_{CC(SX)}$	supply current in SX mode		6.5	8.5	10.5	mA
$I_{CC(SRX)}$	supply current in SRX mode		29.5	38.5	47.5	mA
$I_{CC(STX)}$	supply current in STX mode		15	19.5	24	mA
Pins: RXON, TXON, SXON and SBS						
V_{th}	CMOS threshold voltage	note 1	–	1.25	–	V
V_{IH}	HIGH level input voltage		$0.7V_{CC}$	–	V_{CC}	V
V_{IL}	LOW level input voltage		–0.3	–	+0.8	V
I_{IH}	HIGH level static input current	pins at $V_{CC} - 0.4\text{ V}$	–1	–	+1	μA
I_{IL}	LOW level static input current	pins at 0.4 V	–1	–	+1	μA
Pins: RFINA and RFINB						
V_I	DC input voltage level	receive section on	1.8	2.0	2.2	V
Pins: IFA and IFB						
I_O	DC output current	receive section on	2.3	3.0	3.8	mA
Pins: TXINA and TXINB						
V_I	DC input voltage level	transmit section on	1.9	2.15	2.4	V
Pins: TXOA and TXOB						
I_O	DC output current	transmit section on	0.8	1.0	1.2	mA
Pins: LOINA and LOINB						
V_{LOIN}	DC input voltage level	RXON, TXON or SXON HIGH	2.6	2.9	3.2	V

Note

1. The referenced inputs should be connected to a valid CMOS input level.

2 GHz image rejecting front-end

UAA2077CM

AC CHARACTERISTICS

$V_{CC} = 3.75\text{ V}$; $T_{amb} = -30\text{ to }+75\text{ }^{\circ}\text{C}$; $f_{oRX} = 188\text{ MHz}$; unless otherwise specified.

SYMBOL	PARAMETER	CONDITIONS	MIN.	TYP.	MAX.	UNIT
Receive section (receive section enabled)						
R_{iRX}	RF input resistance (real part of the parallel input impedance)	balanced; at 1960 MHz	–	60	–	Ω
C_{iRX}	RF input capacitance (imaginary part of the parallel input impedance)	balanced; at 1960 MHz	–	0.8	–	pF
f_{iRX}	RF input frequency		1805	–	1990	MHz
RL_{iRX}	return loss on matched RF input	balanced; note 1	15	20	–	dB
G_{CPRX}	conversion power gain	differential RF inputs to differential IF outputs loaded to 1 k Ω differential	19	22	25	dB
G_{rip}	gain ripple as a function of RF frequency	within 100 MHz bandwidth; note 2	–	0.2	0.5	dB
$\Delta G/T$	gain variation with temperature	note 2	–10	–15	–20	mdB/K
$CP1_{RX}$	1 dB compression point	differential RF inputs to differential IF outputs; note 1	–25.5	–24	–	dB
DES	desensitisation	interferer frequency offset: 3 MHz; $P_{in} = -26\text{ dBm}$; interferer frequency offset: 20 MHz, $P_{in} = -23\text{ dBm}$ differential RF inputs to differential IF outputs; note 1	–	–	5	dB
$IP2D_{RX}$	half IF spurious attenuation for –52 dBm input power ($f_{RF} = f_{LO} + 0.5 \times f_{IF}$)	differential RF inputs to differential IF outputs; note 2	37	–	–	dB
$IP3_{RX}$	3rd order intercept point	differential RF inputs to differential IF outputs; note 2	–21.5	–17	–	dBm
NF_{RX}	overall noise figure	differential RF inputs to differential IF outputs $T_{amb} = 25\text{ }^{\circ}\text{C}$; DCS frequency range; note 3 $T_{amb} = 25\text{ }^{\circ}\text{C}$; PCS frequency range; notes 2 and 3 $T_{amb} = -30\text{ to }+65\text{ }^{\circ}\text{C}$; PCS frequency range; notes 2 and 3	–	3.8	–	dB
			–	4.0	4.4	dB
			–	–	5.0	dB
Z_{LRX}	typical application IF output load impedance	balanced	–	1000	–	Ω
RL_{oRX}	return loss on matched IF output	balanced; note 1	15	20	–	dB
f_{oRX}	IF frequency range		–	188	–	MHz
IR	rejection of image frequency	$f_{RF} > f_{LO}$; f_{RF} is the frequency of the wanted signal	30	38	–	dB

2 GHz image rejecting front-end

UAA2077CM

SYMBOL	PARAMETER	CONDITIONS	MIN.	TYP.	MAX.	UNIT
Local oscillator section (receive section enabled)						
f _{iLO}	LO input frequency		1617	–	1802	MHz
R _{iLO}	LO input resistance (real part of the parallel input impedance)	balanced; at 1770 MHz	–	90	–	Ω
C _{iLO}	LO input inductance (imaginary part of the parallel input impedance)	balanced; at 1770 MHz	–	5	–	nH
RL _{iLO}	return loss on matched input (including standby mode)	note 1	10	15	–	dB
ΔRL _{iLO}	return loss variation between SX, SRX and STX modes	linear S ₁₁ variation; note 1	–	20	–	mU
P _{iLO}	LO input power level		–10	–6	0	dBm
RI _{LO}	reverse isolation	LOIN to RFIN at LO frequency; note 2	40	–	–	dB
Transmit section (transmit section enabled)						
Z _{LTX}	TX IF typical load impedance	balanced	–	500	–	Ω
RL _{oTX}	return loss on matched transmitter IF output	note 1	11	15	–	dB
R _{iTX}	TX RF input resistance (real part of the parallel input impedance)	balanced; at 1880 MHz	–	60	–	Ω
C _{iTX}	TX RF input capacitance (imaginary part of the parallel input impedance)	balanced; at 1880 MHz	–	1	–	pF
f _{iTX}	TX mixer input frequency		1600	–	2000	MHz
RL _{iTX}	return loss on matched TX input	note 1	10	15	–	dB
G _{CPTX}	conversion power gain	differential transmitter inputs to differential transmitter IF outputs loaded with 500 Ω differential	6	9	12	dB
f _{oTX}	TX output frequency		50	–	400	MHz
CP1 _{TX}	1 dB input compression point	note 1	–25	–22	–	dBm
IP2 _{TX}	2nd order intercept point	note 2	–	+22	–	dBm
IP3 _{TX}	3rd order intercept point	note 2	–20	–16	–	dBm
NF _{TX}	noise figure	double sideband; notes 2 and 3	–	5	9	dB
I _{TX}	isolation	LOIN to TXIN; note 2	40	–	–	dB
RI _{TX}	reverse isolation	TXIN to LOIN; note 2	38	–	–	dB
Timing						
t _{stu}	start-up time of each block		1	5	20	μs

Notes

1. Measured and guaranteed only on UAA2077CM PCS demonstration board at T_{amb} = 25 °C.
2. Measured and guaranteed only on UAA2077CM PCS demonstration board.
3. This value includes printed-circuit board and balun losses.

2 GHz image rejecting front-end

UAA2077CM

INTERNAL PIN CONFIGURATION

PIN	SYMBOL	DC VOLTAGE (V)	EQUIVALENT CIRCUIT
1	TXINA	2.15	<p style="text-align: right;"><i>MGL205</i></p>
2	TXINB	2.15	
5	RFINA	2.0	
6	RFINB	2.0	
3	V _{CCLNA}	3.75	
8	LNAGND	0	
9	SXON		<p style="text-align: right;"><i>MGL204</i></p>
10	SBS		
11	TXON		
12	RXON		
13	LOINB	2.9	<p style="text-align: right;"><i>MGL206</i></p>
14	LOINA	2.9	
15	V _{CCLLO}	3.75	
16	LOGND	0	

2 GHz image rejecting front-end

UAA2077CM

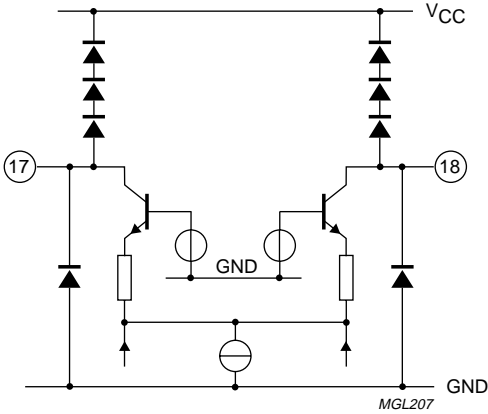
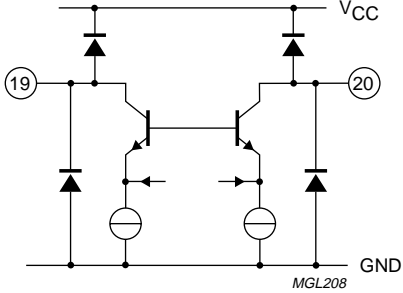
PIN	SYMBOL	DC VOLTAGE (V)	EQUIVALENT CIRCUIT
17	IFA		
18	IFB		
19	TXOA		
20	TXOB		

2 GHz image rejecting front-end

UAA2077CM

APPLICATION INFORMATION

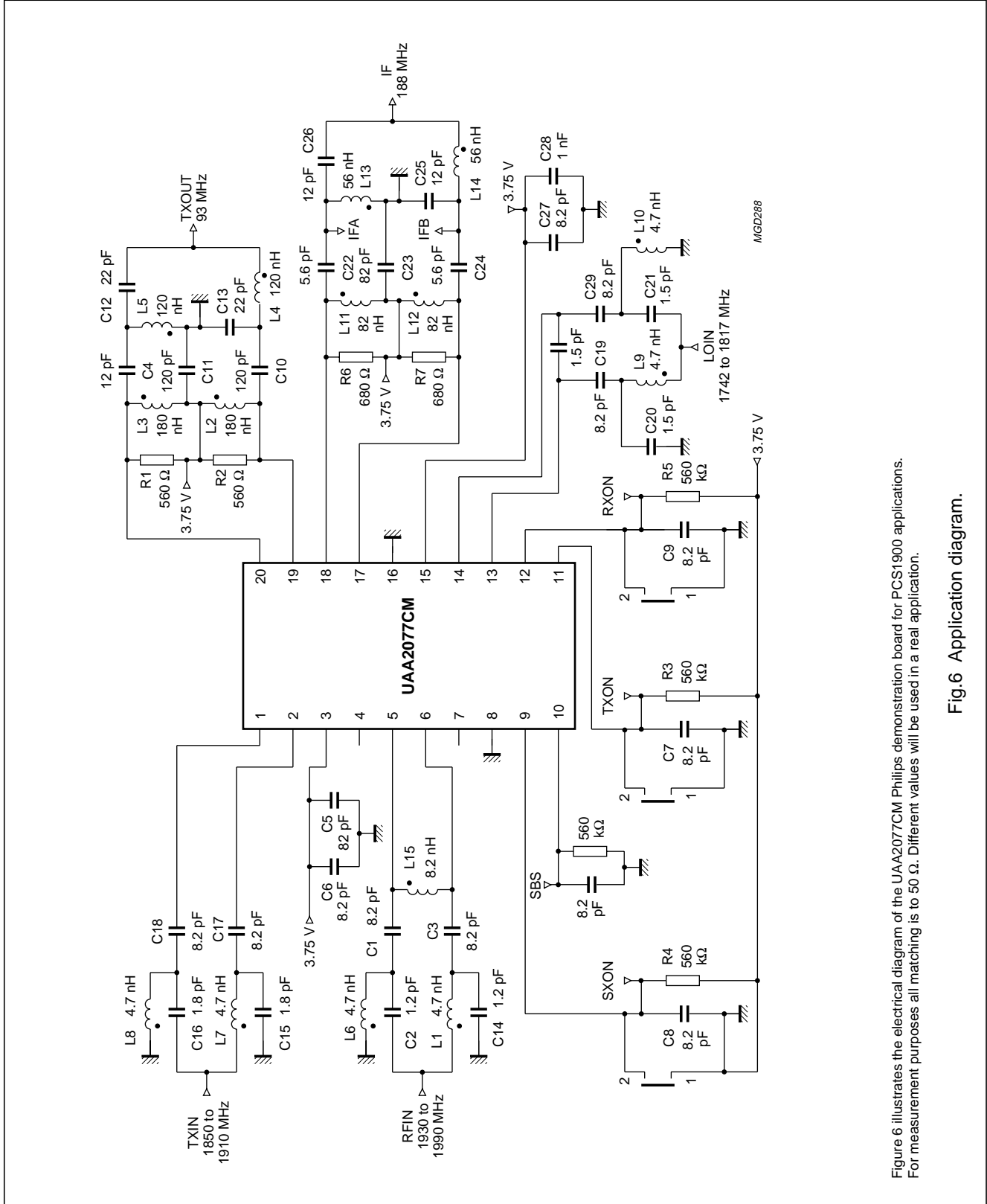

Figure 6 illustrates the electrical diagram of the UAA2077CM Philips demonstration board for PCS1900 applications. For measurement purposes all matching is to 50 Ω. Different values will be used in a real application.

Fig.6 Application diagram.

2 GHz image rejecting front-end

UAA2077CM

PACKAGE OUTLINE

SSOP20: plastic shrink small outline package; 20 leads; body width 4.4 mm

SOT266-1

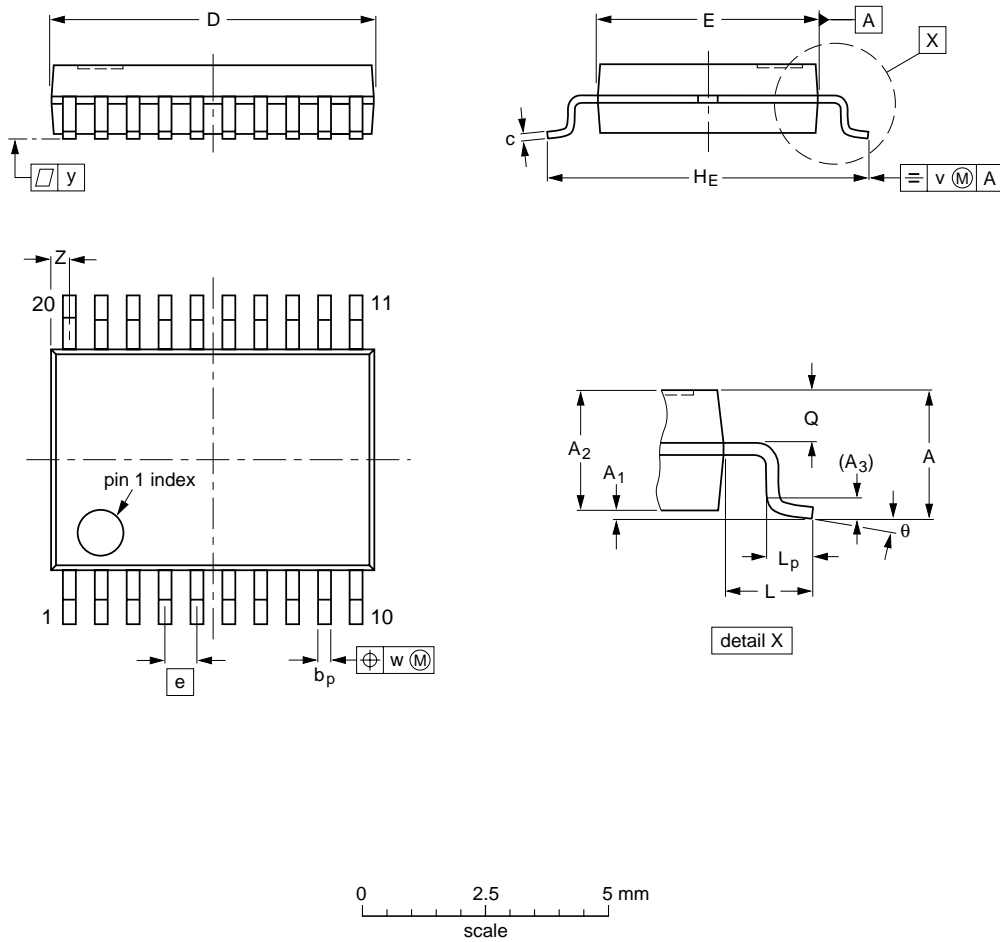

DIMENSIONS (mm are the original dimensions)

UNIT	A max.	A ₁	A ₂	A ₃	b _p	c	D ⁽¹⁾	E ⁽¹⁾	e	H _E	L	L _p	Q	v	w	y	Z ⁽¹⁾	θ
mm	1.5	0.15 0	1.4 1.2	0.25	0.32 0.20	0.20 0.13	6.6 6.4	4.5 4.3	0.65	6.6 6.2	1.0	0.75 0.45	0.65 0.45	0.2	0.13	0.1	0.48 0.18	10° 0°

Note

1. Plastic or metal protrusions of 0.20 mm maximum per side are not included.

OUTLINE VERSION	REFERENCES				EUROPEAN PROJECTION	ISSUE DATE
	IEC	JEDEC	EIAJ			
SOT266-1						90-04-05 95-02-25

2 GHz image rejecting front-end

UAA2077CM

SOLDERING

Introduction

There is no soldering method that is ideal for all IC packages. Wave soldering is often preferred when through-hole and surface mounted components are mixed on one printed-circuit board. However, wave soldering is not always suitable for surface mounted ICs, or for printed-circuits with high population densities. In these situations reflow soldering is often used.

This text gives a very brief insight to a complex technology. A more in-depth account of soldering ICs can be found in our "*IC Package Databook*" (order code 9398 652 90011).

Reflow soldering

Reflow soldering techniques are suitable for all SSOP packages.

Reflow soldering requires solder paste (a suspension of fine solder particles, flux and binding agent) to be applied to the printed-circuit board by screen printing, stencilling or pressure-syringe dispensing before package placement.

Several techniques exist for reflowing; for example, thermal conduction by heated belt. Dwell times vary between 50 and 300 seconds depending on heating method. Typical reflow temperatures range from 215 to 250 °C.

Preheating is necessary to dry the paste and evaporate the binding agent. Preheating duration: 45 minutes at 45 °C.

Wave soldering

Wave soldering is **not** recommended for SSOP packages. This is because of the likelihood of solder bridging due to closely-spaced leads and the possibility of incomplete solder penetration in multi-lead devices.

If wave soldering cannot be avoided, the following conditions must be observed:

- **A double-wave (a turbulent wave with high upward pressure followed by a smooth laminar wave) soldering technique should be used.**
- **The longitudinal axis of the package footprint must be parallel to the solder flow and must incorporate solder thieves at the downstream end.**

Even with these conditions, only consider wave soldering SSOP packages that have a body width of 4.4 mm, that is SSOP16 (SOT369-1) or SSOP20 (SOT266-1).

During placement and before soldering, the package must be fixed with a droplet of adhesive. The adhesive can be applied by screen printing, pin transfer or syringe dispensing. The package can be soldered after the adhesive is cured.

Maximum permissible solder temperature is 260 °C, and maximum duration of package immersion in solder is 10 seconds, if cooled to less than 150 °C within 6 seconds. Typical dwell time is 4 seconds at 250 °C.

A mildly-activated flux will eliminate the need for removal of corrosive residues in most applications.

Repairing soldered joints

Fix the component by first soldering two diagonally-opposite end leads. Use only a low voltage soldering iron (less than 24 V) applied to the flat part of the lead. Contact time must be limited to 10 seconds at up to 300 °C. When using a dedicated tool, all other leads can be soldered in one operation within 2 to 5 seconds between 270 and 320 °C.

2 GHz image rejecting front-end

UAA2077CM

DEFINITIONS

Data sheet status	
Objective specification	This data sheet contains target or goal specifications for product development.
Preliminary specification	This data sheet contains preliminary data; supplementary data may be published later.
Product specification	This data sheet contains final product specifications.
Limiting values	
Limiting values given are in accordance with the Absolute Maximum Rating System (IEC 134). Stress above one or more of the limiting values may cause permanent damage to the device. These are stress ratings only and operation of the device at these or at any other conditions above those given in the Characteristics sections of the specification is not implied. Exposure to limiting values for extended periods may affect device reliability.	
Application information	
Where application information is given, it is advisory and does not form part of the specification.	

LIFE SUPPORT APPLICATIONS

These products are not designed for use in life support appliances, devices, or systems where malfunction of these products can reasonably be expected to result in personal injury. Philips customers using or selling these products for use in such applications do so at their own risk and agree to fully indemnify Philips for any damages resulting from such improper use or sale.

2 GHz image rejecting front-end

UAA2077CM

NOTES

2 GHz image rejecting front-end

UAA2077CM

NOTES

2 GHz image rejecting front-end

UAA2077CM

NOTES

Philips Semiconductors – a worldwide company

Argentina: see South America

Australia: 34 Waterloo Road, NORTH RYDE, NSW 2113,
Tel. +61 2 9805 4455, Fax. +61 2 9805 4466

Austria: Computerstr. 6, A-1101 WIEN, P.O. Box 213, Tel. +43 160 1010,
Fax. +43 160 101 1210

Belarus: Hotel Minsk Business Center, Bld. 3, r. 1211, Volodarski Str. 6,
220050 MINSK, Tel. +375 172 200 733, Fax. +375 172 200 773

Belgium: see The Netherlands

Brazil: see South America

Bulgaria: Philips Bulgaria Ltd., Energoproject, 15th floor,
51 James Bourchier Blvd., 1407 SOFIA,
Tel. +359 2 689 211, Fax. +359 2 689 102

Canada: PHILIPS SEMICONDUCTORS/COMPONENTS,
Tel. +1 800 234 7381

China/Hong Kong: 501 Hong Kong Industrial Technology Centre,
72 Tat Chee Avenue, Kowloon Tong, HONG KONG,
Tel. +852 2319 7888, Fax. +852 2319 7700

Colombia: see South America

Czech Republic: see Austria

Denmark: Prags Boulevard 80, PB 1919, DK-2300 COPENHAGEN S,
Tel. +45 32 88 2636, Fax. +45 31 57 0044

Finland: Sinikalliontie 3, FIN-02630 ESPOO,
Tel. +358 9 615800, Fax. +358 9 61580920

France: 4 Rue du Port-aux-Vins, BP317, 92156 SURESNES Cedex,
Tel. +33 1 40 99 6161, Fax. +33 1 40 99 6427

Germany: Hammerbrookstraße 69, D-20097 HAMBURG,
Tel. +49 40 23 53 60, Fax. +49 40 23 536 300

Greece: No. 15, 25th March Street, GR 17778 TAVROS/ATHENS,
Tel. +30 1 4894 339/239, Fax. +30 1 4814 240

Hungary: see Austria

India: Philips INDIA Ltd, Band Box Building, 2nd floor,
254-D, Dr. Annie Besant Road, Worli, MUMBAI 400 025,
Tel. +91 22 493 8541, Fax. +91 22 493 0966

Indonesia: see Singapore

Ireland: Newstead, Clonskeagh, DUBLIN 14,
Tel. +353 1 7640 000, Fax. +353 1 7640 200

Israel: RAPAC Electronics, 7 Kehilat Saloniki St, PO Box 18053,
TEL AVIV 61180, Tel. +972 3 645 0444, Fax. +972 3 649 1007

Italy: PHILIPS SEMICONDUCTORS, Piazza IV Novembre 3,
20124 MILANO, Tel. +39 2 6752 2531, Fax. +39 2 6752 2557

Japan: Philips Bldg 13-37, Kohnan 2-chome, Minato-ku, TOKYO 108,
Tel. +81 3 3740 5130, Fax. +81 3 3740 5077

Korea: Philips House, 260-199 Itaewon-dong, Yongsan-ku, SEOUL,
Tel. +82 2 709 1412, Fax. +82 2 709 1415

Malaysia: No. 76 Jalan Universiti, 46200 PETALING JAYA, SELANGOR,
Tel. +60 3 750 5214, Fax. +60 3 757 4880

Mexico: 5900 Gateway East, Suite 200, EL PASO, TEXAS 79905,
Tel. +9-5 800 234 7381

Middle East: see Italy

Netherlands: Postbus 90050, 5600 PB EINDHOVEN, Bldg. VB,
Tel. +31 40 27 82785, Fax. +31 40 27 88399

New Zealand: 2 Wagener Place, C.P.O. Box 1041, AUCKLAND,
Tel. +64 9 849 4160, Fax. +64 9 849 7811

Norway: Box 1, Manglerud 0612, OSLO,
Tel. +47 22 74 8000, Fax. +47 22 74 8341

Philippines: Philips Semiconductors Philippines Inc.,
106 Valero St. Salcedo Village, P.O. Box 2108 MCC, MAKATI,
Metro MANILA, Tel. +63 2 816 6380, Fax. +63 2 817 3474

Poland: Ul. Lukiska 10, PL 04-123 WARSZAWA,
Tel. +48 22 612 2831, Fax. +48 22 612 2327

Portugal: see Spain

Romania: see Italy

Russia: Philips Russia, Ul. Usatcheva 35A, 119048 MOSCOW,
Tel. +7 095 755 6918, Fax. +7 095 755 6919

Singapore: Lorong 1, Toa Payoh, SINGAPORE 1231,
Tel. +65 350 2538, Fax. +65 251 6500

Slovakia: see Austria

Slovenia: see Italy

South Africa: S.A. PHILIPS Pty Ltd., 195-215 Main Road Martindale,
2092 JOHANNESBURG, P.O. Box 7430 Johannesburg 2000,
Tel. +27 11 470 5911, Fax. +27 11 470 5494

South America: Rua do Rocio 220, 5th floor, Suite 51,
04552-903 São Paulo, SÃO PAULO - SP, Brazil,
Tel. +55 11 821 2333, Fax. +55 11 829 1849

Spain: Balmes 22, 08007 BARCELONA,
Tel. +34 3 301 6312, Fax. +34 3 301 4107

Sweden: Kottbygatan 7, Akalla, S-16485 STOCKHOLM,
Tel. +46 8 632 2000, Fax. +46 8 632 2745

Switzerland: Allmendstrasse 140, CH-8027 ZÜRICH,
Tel. +41 1 488 2686, Fax. +41 1 481 7730

Taiwan: Philips Semiconductors, 6F, No. 96, Chien Kuo N. Rd., Sec. 1,
TAIPEI, Taiwan Tel. +886 2 2134 2865, Fax. +886 2 2134 2874

Thailand: PHILIPS ELECTRONICS (THAILAND) Ltd.,
209/2 Sanpavuth-Bangna Road Prakanong, BANGKOK 10260,
Tel. +66 2 745 4090, Fax. +66 2 398 0793

Turkey: Talatpasa Cad. No. 5, 80640 GÜLTEPE/ISTANBUL,
Tel. +90 212 279 2770, Fax. +90 212 282 6707

Ukraine: PHILIPS UKRAINE, 4 Patrice Lumumba str., Building B, Floor 7,
252042 KIEV, Tel. +380 44 264 2776, Fax. +380 44 268 0461

United Kingdom: Philips Semiconductors Ltd., 276 Bath Road, Hayes,
MIDDLESEX UB3 5BX, Tel. +44 181 730 5000, Fax. +44 181 754 8421

United States: 811 East Arques Avenue, SUNNYVALE, CA 94088-3409,
Tel. +1 800 234 7381

Uruguay: see South America

Vietnam: see Singapore

Yugoslavia: PHILIPS, Trg N. Pasica 5/v, 11000 BEOGRAD,
Tel. +381 11 625 344, Fax. +381 11 635 777

For all other countries apply to: Philips Semiconductors, Marketing & Sales Communications,
Building BE-p, P.O. Box 218, 5600 MD EINDHOVEN, The Netherlands, Fax. +31 40 27 24825

Internet: <http://www.semiconductors.philips.com>

© Philips Electronics N.V. 1997

SCA55

All rights are reserved. Reproduction in whole or in part is prohibited without the prior written consent of the copyright owner.

The information presented in this document does not form part of any quotation or contract, is believed to be accurate and reliable and may be changed without notice. No liability will be accepted by the publisher for any consequence of its use. Publication thereof does not convey nor imply any license under patent- or other industrial or intellectual property rights.

Printed in The Netherlands

437027/1200/02/pp20

Date of release: 1997 Sep 24

Document order number: 9397 750 02731

Let's make things better.

**Philips
Semiconductors**



PHILIPS

SUNSTAR 商斯达实业集团是集研发、生产、工程、销售、代理经销、技术咨询、信息服务等为一体的高科技企业，是专业高科技电子产品生产厂家，是具有 10 多年历史的专业电子元器件供应商，是中国最早和最大的仓储式连锁规模经营大型综合电子零部件代理分销商之一，是一家专业代理和分销世界各大品牌 IC 芯片和电子元器件的连锁经营综合性国际公司，专业经营进口、国产名厂名牌电子元件，型号、种类齐全。在香港、北京、深圳、上海、西安、成都等全国主要电子市场设有直属分公司和产品展示展销窗口门市部专卖店及代理分销商，已在全国范围内建成强大统一的供货和代理分销网络。我们专业代理经销、开发生产电子元器件、集成电路、传感器、微波光电元器件、工控机/DOC/DOM 电子盘、专用电路、单片机开发、MCU/DSP/ARM/FPGA 软件硬件、二极管、三极管、模块等，是您可靠的一站式现货配套供应商、方案提供商、部件功能模块开发配套商。商斯达实业公司拥有庞大的资料库，有数位毕业于著名高校——有中国电子工业摇篮之称的西安电子科技大学（西军电）并长期从事国防尖端科技研究的高级工程师为您精挑细选、量身订做各种高科技电子元器件，并解决各种技术问题。

微波光电部专业代理经销高频、微波、光纤、光电元器件、组件、部件、模块、整机；电磁兼容元器件、材料、设备；微波 CAD、EDA 软件、开发测试仿真工具；微波、光纤仪器仪表。欢迎国外高科技微波、光纤厂商将优秀产品介绍到中国、共同开拓市场。长期大量现货专业批发高频、微波、卫星、光纤、电视、CATV 器件：晶振、VCO、连接器、PIN 开关、变容二极管、开关二极管、低噪晶体管、功率电阻及电容、放大器、功率管、MMIC、混频器、耦合器、功分器、振荡器、合成器、衰减器、滤波器、隔离器、环行器、移相器、调制解调器；光电子元件和组件：红外发射管、红外接收管、光电开关、光敏管、发光二极管和发光二极管组件、半导体激光二极管和激光器组件、光电探测器和光接收组件、光发射接收模块、光纤激光器和光放大器、光调制器、光开关、DWDM 用光发射和接收器件、用户接入系统光收发器件与模块、光纤连接器、光纤跳线/尾纤、光衰减器、光纤适配器、光隔离器、光耦合器、光环行器、光复用器/转换器；无线收发芯片和模组、蓝牙芯片和模组。

更多产品请看本公司产品专用销售网站：

商斯达中国传感器科技信息网：<http://www.sensor-ic.com/>

商斯达工控安防网：<http://www.pc-ps.net/>

商斯达电子元器件网：<http://www.sunstare.com/>

商斯达微波光电产品网：[HTTP://www.rfoe.net/](http://www.rfoe.net/)

商斯达消费电子产品网：[//www.icasic.com/](http://www.icasic.com/)

商斯达实业科技产品网：[//www.sunstars.cn/](http://www.sunstars.cn/) 微波元器件销售热线：

地址：深圳市福田区福华路福庆街鸿图大厦 1602 室

电话：0755-82884100 83397033 83396822 83398585

传真：0755-83376182 (0) 13823648918 MSN: SUNS8888@hotmail.com

邮编：518033 E-mail:szss20@163.com QQ: 195847376

深圳赛格展销部：深圳华强北路赛格电子市场 2583 号 电话：0755-83665529 25059422

技术支持：0755-83394033 13501568376

欢迎索取免费详细资料、设计指南和光盘；产品凡多，未能尽录，欢迎来电查询。

北京分公司：北京海淀区知春路 132 号中发电子大厦 3097 号

TEL: 010-81159046 82615020 13501189838 FAX: 010-62543996

上海分公司：上海市北京东路 668 号上海赛格电子市场 D125 号

TEL: 021-28311762 56703037 13701955389 FAX: 021-56703037

西安分公司：西安高新开发区 20 所(中国电子科技集团导航技术研究所)

西安劳动南路 88 号电子商城二楼 D23 号

TEL: 029-81022619 13072977981 FAX:029-88789382