

# M6MGB/T321S8TP

**33,554,432-BIT (2,097,152 - WORD BY 16-BIT/4,194,304-WORD BY 8-BIT) CMOS  
3.0V-ONLY FLASH MEMORY &  
8,388,608-BIT (524,288-WORD BY 16-BIT/1,048,576-WORD BY 8-BIT) CMOS SRAM  
Stacked -  $\mu$  MCP (micro Multi Chip Package)**

## Description

The M6MGB/T321S8TP is a Stacked micro Multi Chip Package (S-  $\mu$ MCP) that contents 32M-bit Flash memory and 8M-bit Static RAM in a 52-pin TSOP for lead free use.

32M-bit Flash memory is a 4,194,304 bytes / 2,097,152 words, 3.0V-only, and high performance non-volatile memory fabricated by CMOS technology for the peripheral circuit and DINOR (Divided bit-line NOR) architecture for the memory cell.

8M-bit SRAM is a 1,048,576 bytes / 524,288 words asynchronous SRAM fabricated by silicon-gate CMOS technology.

M6MGB/T321S8TP is suitable for the application of the mobile-communication-system to reduce both the mount space and weight.

M6MGB/T321S8TP provides for Software Lock Release function. Usually, all memory blocks are locked and can not be programed or erased, when F-WP# is low. Using Software Lock Release function, program or erase operation can be excuted.

## Features

Access Time	Flash	85ns (Max.)
	SRAM	85ns (Max.)
Supply Voltage		VCC=2.7 ~ 3.0V
Ambient Temperature		Ta=-40 ~ 85 °C
Package		52pin TSOP(Type-II), Lead pitch 0.4mm Outer-lead finishing:Sn-Cu

## Application

Mobile communication products

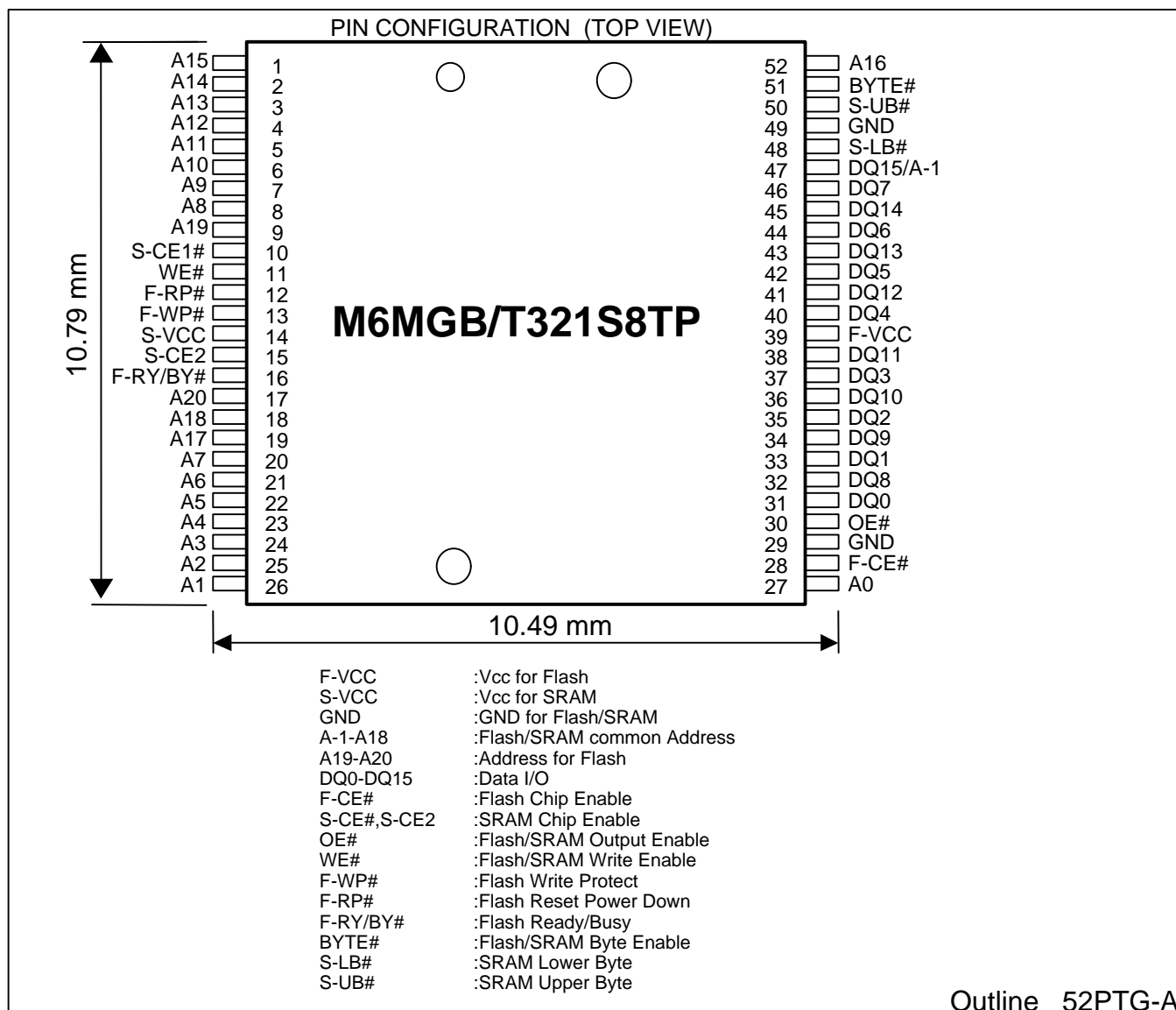

# M6MGB/T321S8TP

33,554,432-BIT (2,097,152 - WORD BY 16-BIT/4,194,304-WORD BY 8-BIT) CMOS  
3.0V-ONLY FLASH MEMORY &  
8,388,608-BIT (524,288-WORD BY 16-BIT/1,048,576-WORD BY 8-BIT) CMOS SRAM  
Stacked -  $\mu$  MCP (micro Multi Chip Package)

## MCP Block Diagram

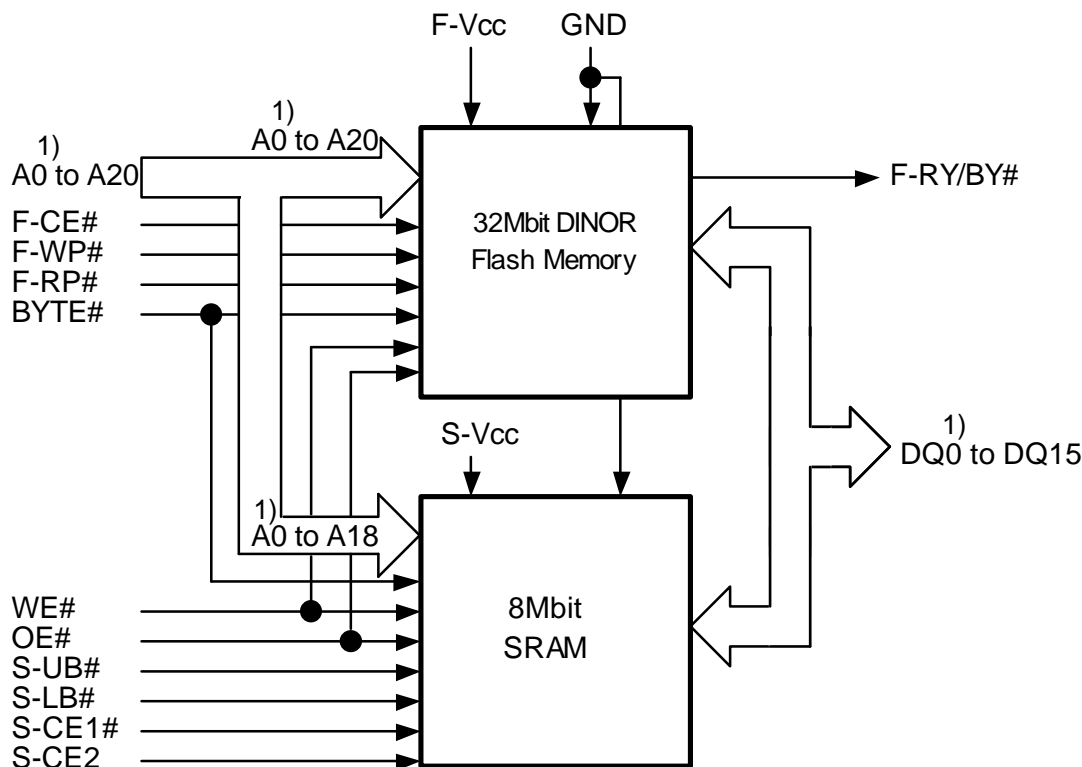

Note 1): In case of x8 organization, A-1 is added, and only Lower Byte data(DQ0 to DQ7) are assigned to I/O and Upper Byte data(DQ8 to DQ15) are High-Z.

Note 2): In the data sheet there are "VCC"s which mean "F-VCC" or "S-VCC". In the SRAM part there are "UB#" and "LB#" which mean "S-UB#" and "S-LB#", respectively.

## Capacitance

Symbol	Parameter		Conditions	Limits			Unit
				Min.	Typ.	Max.	
CIN	Input capacitance	A20-A0, OE#, WE#, F-CE#, F-WP#, F-RP#, S-CE1#, S-CE2, BYTE#, S-LB#, S-UB#	Ta=25°C, f=1MHz, Vin=Vout=0V			18	pF
COUT	Output Capacitance	DQ15-DQ0,F-RY/BY#				22	pF

**M6MGB/T321S8TP**

**33,554,432-BIT (2,097,152 - WORD BY 16-BIT/4,194,304-WORD BY 8-BIT) CMOS  
3.0V-ONLY FLASH MEMORY &**

**8,388,608-BIT (524,288-WORD BY 16-BIT/1,048,576-WORD BY 8-BIT) CMOS SRAM  
Stacked -  $\mu$  MCP (micro Multi Chip Package)**

## Renesas Technology Corp.

Nippon Bldg.,6-2,Otemachi 2-chome,Chiyoda-ku,Tokyo,100-0004 Japan

### Keep safety first in your circuit designs!

- Renesas Technology Corporation puts the maximum effort into making semiconductor products better and more reliable, but there is always the possibility that trouble may occur with them. Trouble with semiconductors may lead to personal injury, fire or property damage. Remember to give due consideration to safety when making your circuit designs, with appropriate measures such as (i) placement of substitutive, auxiliary circuits, (ii) use of nonflammable material or (iii) prevention against any malfunction or mishap.

### Notes regarding these materials

- These materials are intended as a reference to assist our customers in the selection of the Renesas Technology Corporation product best suited to the customer's application; they do not convey any license under any intellectual property rights, or any other rights, belonging to Renesas Technology Corporation or a third party.
- Renesas Technology Corporation assumes no responsibility for any damage, or infringement of any third-party's rights, originating in the use of any product data, diagrams, charts, programs, algorithms, or circuit application examples contained in these materials.
- All information contained in these materials, including product data, diagrams, charts, programs and algorithms represents information on products at the time of publication of these materials, and are subject to change by Renesas Technology Corporation without notice due to product improvements or other reasons. It is therefore recommended that customers contact Renesas Technology Corporation or an authorized Renesas Technology Corporation product distributor for the latest product information before purchasing a product listed herein. The information described here may contain technical inaccuracies or typographical errors. Renesas Technology Corporation assumes no responsibility for any damage, liability, or other loss rising from these inaccuracies or errors. Please also pay attention to information published by Renesas Technology Corporation by various means, including the Renesas Technology Corporation Semiconductor home page (<http://www.renesas.com>).
- When using any or all of the information contained in these materials, including product data, diagrams, charts, programs, and algorithms, please be sure to evaluate all information as a total system before making a final decision on the applicability of the information and products. Renesas Technology Corporation assumes no responsibility for any damage, liability or other loss resulting from the information contained herein.
- Renesas Technology Corporation semiconductors are not designed or manufactured for use in a device or system that is used under circumstances in which human life is potentially at stake. Please contact Renesas Technology Corporation or an authorized Renesas Technology Corporation product distributor when considering the use of a product contained herein for any specific purposes, such as apparatus or systems for transportation, vehicular, medical, aerospace, nuclear, or undersea repeater use.
- The prior written approval of Renesas Technology Corporation is necessary to reprint or reproduce in whole or in part these materials.
- If these products or technologies are subject to the Japanese export control restrictions, they must be exported under a license from the Japanese government and cannot be imported into a country other than the approved destination.
- Any diversion or reexport contrary to the export control laws and regulations of Japan and/or the country of destination is prohibited.
- Please contact Renesas Technology Corporation for further details on these materials or the products contained therein.