

To all our customers

Regarding the change of names mentioned in the document, such as Mitsubishi Electric and Mitsubishi XX, to Renesas Technology Corp.

The semiconductor operations of Hitachi and Mitsubishi Electric were transferred to Renesas Technology Corporation on April 1st 2003. These operations include microcomputer, logic, analog and discrete devices, and memory chips other than DRAMs (flash memory, SRAMs etc.) Accordingly, although Mitsubishi Electric, Mitsubishi Electric Corporation, Mitsubishi Semiconductors, and other Mitsubishi brand names are mentioned in the document, these names have in fact all been changed to Renesas Technology Corp. Thank you for your understanding. Except for our corporate trademark, logo and corporate statement, no changes whatsoever have been made to the contents of the document, and these changes do not constitute any alteration to the contents of the document itself.

Note : Mitsubishi Electric will continue the business operations of high frequency & optical devices and power devices.

Renesas Technology Corp.
Customer Support Dept.
April 1, 2003

PRELIMINARY
 Notice: This is not a final specification.
 Some parametric limits are subject to change.

MITSUBISHI MICROCOMPUTERS

38C2 Group (A Version)

SINGLE-CHIP 8-BIT CMOS MICROCOMPUTER

DESCRIPTION

The 38C2 group (A version) is the 8-bit microcomputer based on the 740 family core technology.

The 38C2 (A version) group has an LCD drive control circuit, a 10-channel A-D converter, and a serial I/O as additional functions.

The various microcomputers in the 38C2 group (A version) include variations of internal memory size and packaging. For details, refer to the section on part numbering.

FEATURES

- Basic machine-language instructions 71
- The minimum instruction execution time 0.40 μ s
 (at 10 MHz oscillation frequency)
- Memory size
 - ROM 16 K to 60 K bytes
 - RAM 640 to 2048 bytes
- Programmable input/output ports 51 (common to SEG: 24)
- Interrupts 18 sources, 16 vectors
- Timers 8-bit \times 4, 16-bit \times 2
- A-D converter 10-bit \times 8 channels
- Serial I/O 8-bit \times 2 (UART or Clock-synchronized)
- PWM 10-bit \times 2, 16-bit \times 1 (common to IGBT output)
- LCD drive control circuit
 - Bias 1/2, 1/3
 - Duty 1/2, 1/3, 1/4
 - Common output 4
 - Segment output 24
- Two clock generating circuits
 (connect to external ceramic resonator or quartz-crystal oscillator)
- Watchdog timer 8-bit \times 1
- LED direct drive port 8
 (average current: 15 mA, peak current: 30 mA, total current: 90 mA)
- Power source voltage
 - Mask ROM version
 - In frequency/2 mode 4.5 to 5.5 V
 (at 10 MHz oscillation frequency)
 - In frequency/2 mode 4.0 to 5.5 V
 (at 8 MHz oscillation frequency)
 - In frequency/4 mode 1.8 to 5.5 V
 (at 4 MHz oscillation frequency, A-D operation excluded)
 - In low-speed mode 1.8 to 5.5 V
 (at 32 kHz oscillation frequency)
 - Flash memory version
 - In frequency/2 mode 4.5 to 5.5 V
 (at 10 MHz oscillation frequency)
 - In frequency/2 mode 4.0 to 5.5 V
 (at 8 MHz oscillation frequency)
 - In frequency/4 mode 2.5 to 5.5 V
 (at 8 MHz oscillation frequency)
 - In low-speed mode 2.5 to 5.5 V
 (at 32 kHz oscillation frequency)
- Power dissipation
 - In frequency/2 mode (at 8 MHz oscillation frequency, $V_{CC} = 5$ V)
 - Mask ROM version 14 mW
 - Flash memory version 25 mW
 - In low-speed mode (at 32 kHz oscillation frequency, $V_{CC} = 3$ V)
 - Mask ROM version 24 μ W
 - Flash memory version 375 μ W
- Operating temperature range - 20 to 85°C

**PIN CONFIGURATION
 (TOP VIEW)**

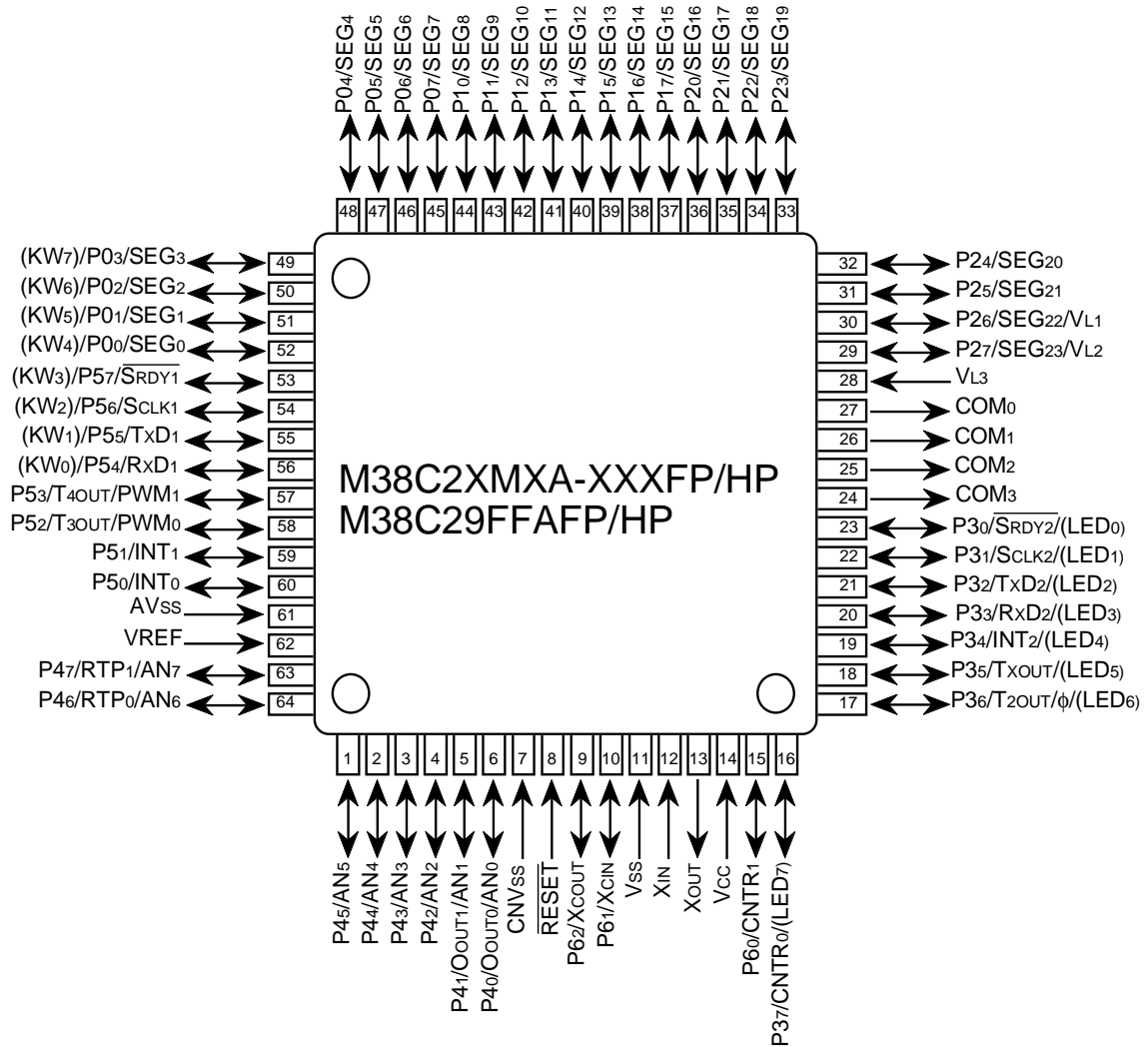

Package type : 64P6U-A/64P6Q-A

Fig. 1 M38C2XMXA-XXXFP/HP pin configuration

PRELIMINARY
 Notice: This is not a final specification.
 Some parametric limits are subject to change.

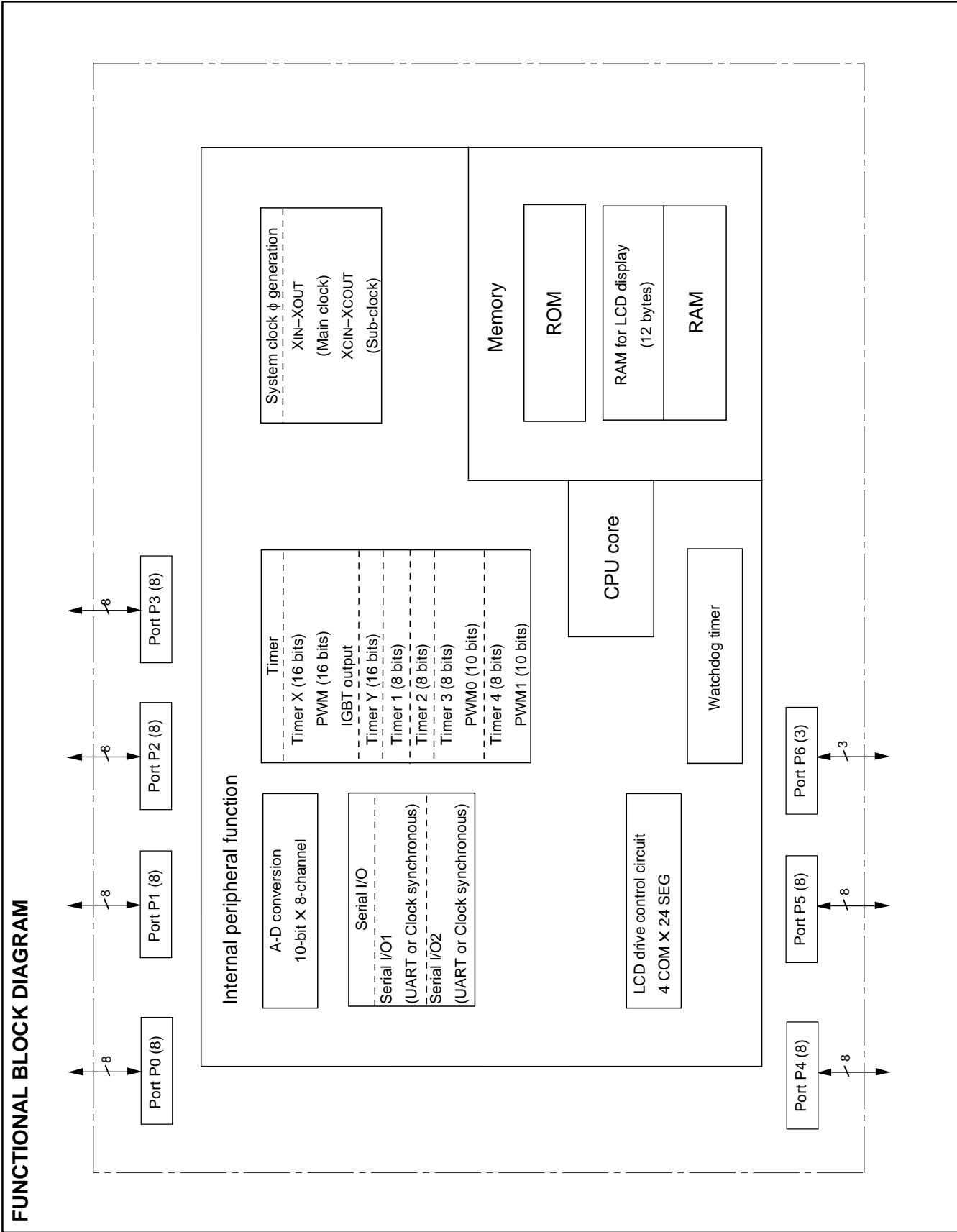

Fig. 2 Functional block diagram

PIN DESCRIPTION

Table 1 Pin description (1)

Pin	Name	Function	Function except a port function	
VCC, VSS	Power source	• Apply voltage of 1.8 V to 5.5 V to VCC, and 0 V to VSS.		
VREF	Analog reference voltage	• Reference voltage input pin for A-D converter.		
AVSS	Analog power source	• GND input pin for A-D converter. Connect to VSS.		
RESET	Reset input	• Reset input pin for active "L."		
XIN	Clock input	• Input and output pins for the main clock generating circuit. • Feedback resistor is built in between XIN pin and XOUT pin.		
XOUT	Clock output	• Connect a ceramic resonator or a quartz-crystal oscillator between the XIN and XOUT pins to set the oscillation frequency. When an external clock is used, connect the clock source to XIN, and leave XOUT pin open.		
VL3	LCD power source	• Input $0 \leq VL1 \leq VL2 \leq VL3 \leq VCC$ voltage. • Input 0 – VL3 voltage to LCD.		
COM0 – COM3	Common output	• LCD common output pins. • COM2 and COM3 are not used at 1/2 duty ratio. • COM3 is not used at 1/3 duty ratio.		
P00/SEG0 – P03/SEG3	I/O port P0	• 8-bit I/O port. • CMOS compatible input level. • CMOS 3-state output structure. • I/O direction register allows each pin to be individually programmed as either input or output. • Pull-up control is enabled in a bit unit.	• LCD segment output pins	• Key input interrupt pins
P04/SEG4 – P07/SEG7				
P10/SEG8 – P17/SEG15				
P20/SEG16 – P25/SEG21	I/O port P2			• LCD power source input pins
P26/SEG22/VL1 P27/SEG23/VL2				
P30/SRDY2 P31/SCLK2 P32/TxD2 P33/RxD2	I/O port P3		• Serial I/O2 function pins	
P34/INT2				
P35/TXOUT P36/T2OUT/φ				
P37/CNTR0				
P40/OOUT0/AN0 P41/OOUT1/AN1	I/O port P4		• AD converter input pins	• Oscillation external output pins
P42/AN2 – P45/AN5				
P46/RTP0/AN6 P47/RTP1/AN7				
P50/INT0 P51/INT1	I/O port P5		• External interrupt pins	
P52/T3OUT/PWM0 P53/T4OUT/PWM1				
P54/RxD1 P55/TxD1 P56/SCLK1 P57/SRDY1				

PRELIMINARY
Notice: This is not a final specification.
Some parametric limits are subject to change.

PIN DESCRIPTION

Table 2 Pin description (2)

Pin	Name	Function	Function except a port function
P60/CNTR1	I/O port P6	<ul style="list-style-type: none">• 3-bit I/O port.• CMOS compatible input level.• CMOS 3-state output structure.• I/O direction register allows each pin to be individually programmed as either input or output.• Pull-up control is enabled.	<ul style="list-style-type: none">• Timer Y function pin
P61/XCIN			<ul style="list-style-type: none">• Sub clock generating I/O pin (resonator connected)
P62/XCOUT			
CNVss	CNVss	<ul style="list-style-type: none">• VPP power input pin in the flash mode. When MCU is operating, connect to Vss.	

PART NUMBERING

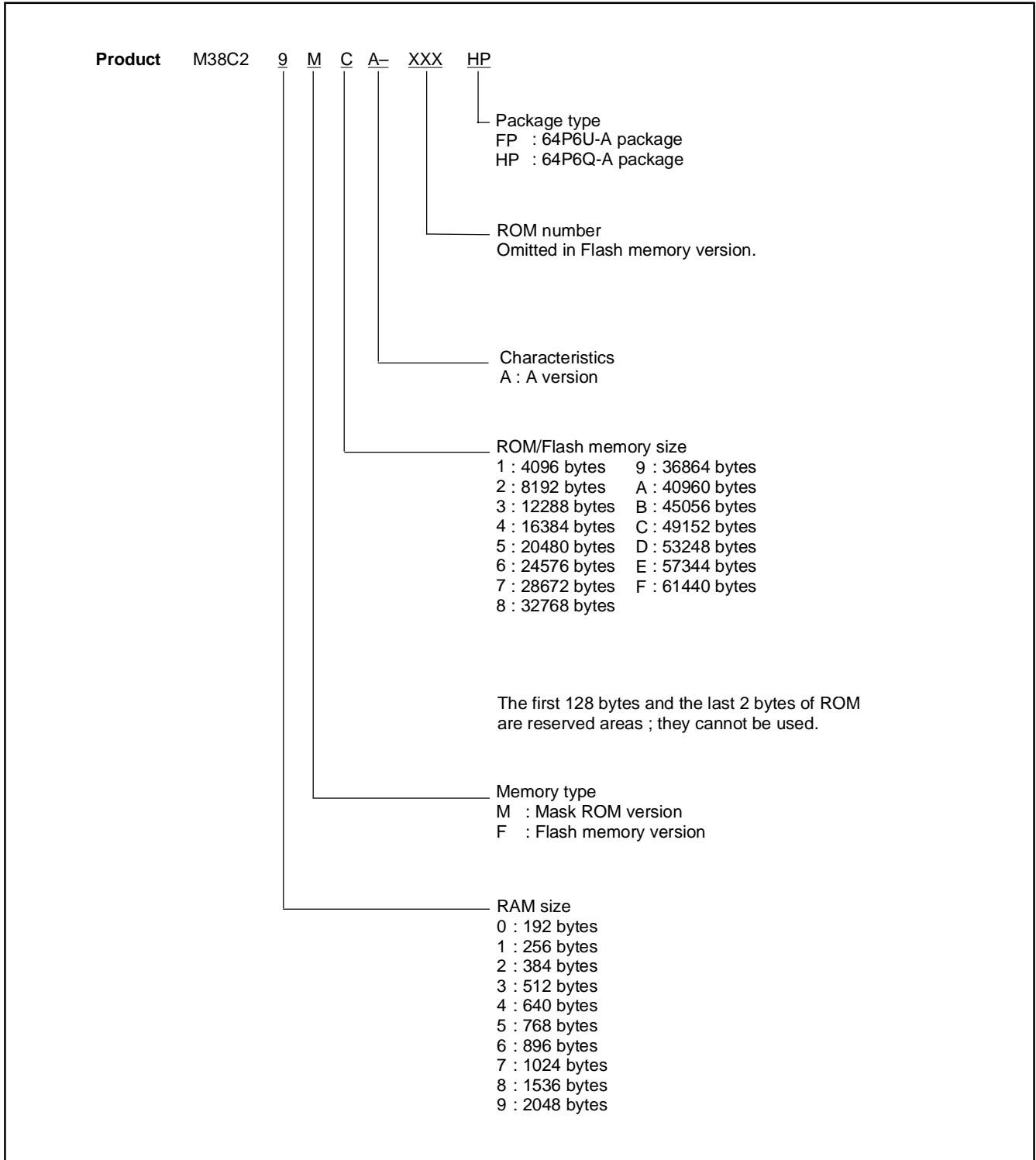

Fig. 3 Part numbering

PRELIMINARY
 Notice: This is not a final specification.
 Some parametric limits are subject to change.

MITSUBISHI MICROCOMPUTERS
38C2 Group (A Version)

SINGLE-CHIP 8-BIT CMOS MICROCOMPUTER

GROUP EXPANSION

Mitsubishi plans to expand the 38C2 group (A version) as follows.

Packages

64P6Q-A 0.5 mm-pitch plastic molded QFP
 64P6U-A 0.8 mm-pitch plastic molded QFP

Memory Type

Support for mask ROM, Flash memory versions

Memory Size

ROM/flash memory size 16 K to 60 K bytes
 RAM size 640 to 2048 bytes

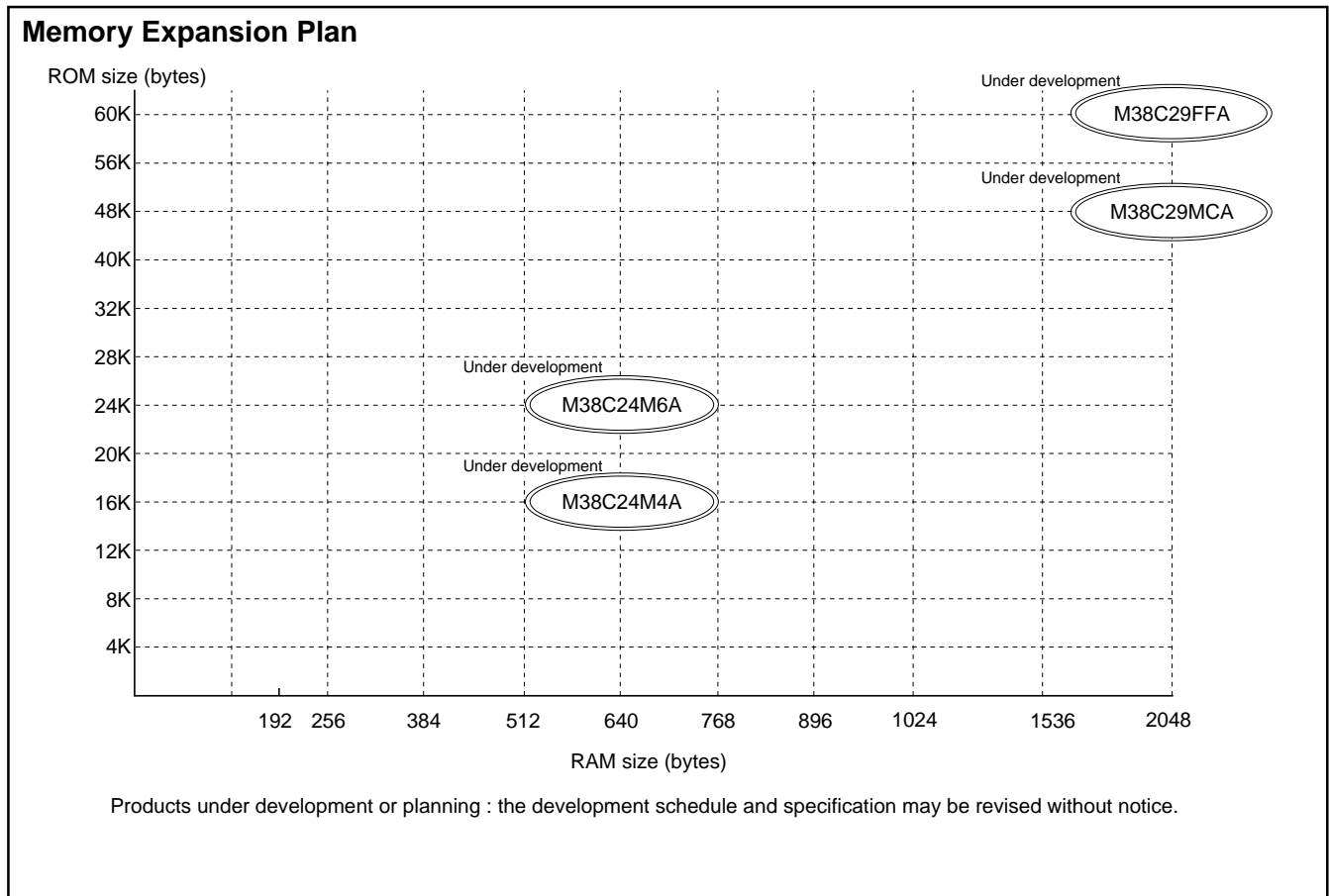

Fig. 4 Memory expansion plan

Currently supported products are listed below.

Table 3 Support products

As of Feb. 2003

Product name	ROM size (bytes) ROM size for User in ()	RAM size (bytes)	Package	Remarks
M38C29MCA-XXXFP	49152 (49022)	2048	64P6U-A	Mask ROM version
M38C29MCA-XXXHP			64P6Q-A	Mask ROM version
M38C24M6A-XXXFP	24576 (24446)	640	64P6U-A	Mask ROM version
M38C24M6A-XXXHP			64P6Q-A	Mask ROM version
M38C24M4A-XXXFP	16384 (16254)	640	64P6U-A	Mask ROM version
M38C24M4A-XXXHP			64P6Q-A	Mask ROM version
M38C29FFAFP	61440 (61310)	2048	64P6U-A	Flash memory version
M38C29FFAHP			64P6Q-A	Flash memory version

FUNCTIONAL DESCRIPTION
Central Processing Unit (CPU)

The 38C2 group uses the standard 740 Family instruction set. Refer to the table of 740 Family addressing modes and machine instructions or the 740 Family Software Manual for details on the instruction set.

Machine-resident 740 Family instructions are as follows:

- The FST and SLW instructions cannot be used.
- The STP, WIT, MUL, and DIV instructions can be used.

The central processing unit (CPU) has six registers. Figure 5 shows the 740 Family CPU register structure.

[Accumulator (A)]

The accumulator is an 8-bit register. Data operations such as arithmetic data transfer, etc., are executed mainly through the accumulator.

[Index Register X (X)]

The index register X is an 8-bit register. In the index addressing modes, the value of the OPERAND is added to the contents of register X and specifies the real address.

[Index Register Y (Y)]

The index register Y is an 8-bit register. In partial instruction, the value of the OPERAND is added to the contents of register Y and specifies the real address.

[Stack Pointer (S)]

The stack pointer is an 8-bit register used during subroutine calls and interrupts. This register indicates start address of stored area (stack) for storing registers during subroutine calls and interrupts.

The low-order 8 bits of the stack address are determined by the contents of the stack pointer. The high-order 8 bits of the stack address are determined by the stack page selection bit. If the stack page selection bit is "0", the high-order 8 bits becomes "0016". If the stack page selection bit is "1", the high-order 8 bits becomes "0116".

The operations of pushing register contents onto the stack and popping them from the stack are shown in Figure 6.

Store registers other than those described in Figure 6 with program when the user needs them during interrupts or subroutine calls.

[Program Counter (PC)]

The program counter is a 16-bit counter consisting of two 8-bit registers PCH and PCL. It is used to indicate the address of the next instruction to be executed.

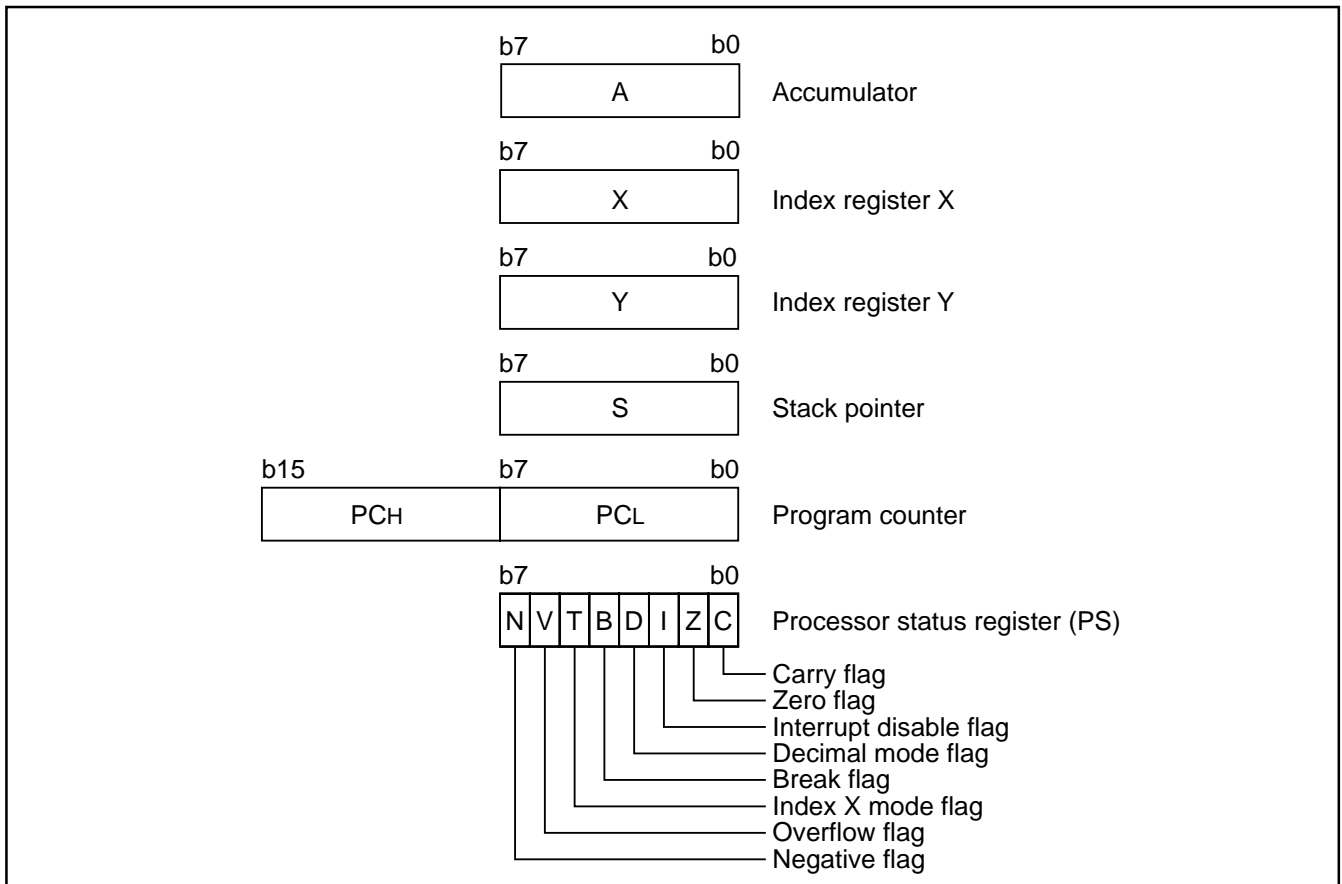

Fig. 5 740 Family CPU register structure

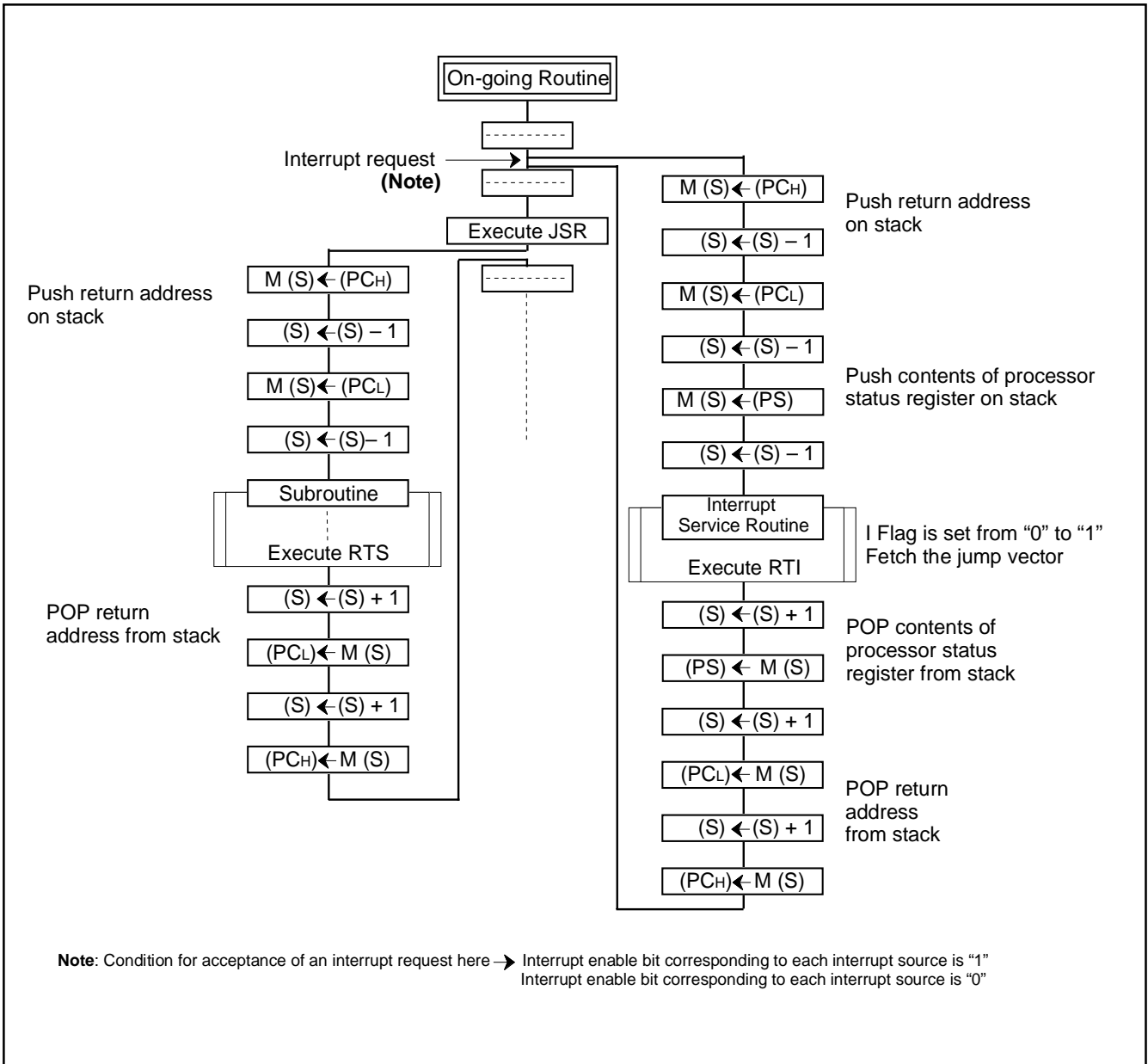

Fig. 6 Register push and pop at interrupt generation and subroutine call

Table 4 Push and pop instructions of accumulator or processor status register

	Push instruction to stack	Pop instruction from stack
Accumulator	PHA	PLA
Processor status register	PHP	PLP

[Processor Status Register (PS)]

The processor status register is an 8-bit register consisting of 5 flags which indicate the status of the processor after an arithmetic operation and 3 flags which decide MCU operation. Branch operations can be performed by testing the Carry (C) flag, Zero (Z) flag, Overflow (V) flag, or the Negative (N) flag. In decimal mode, the Z, V, N flags are not valid.

- Bit 0: Carry flag (C)
 The C flag contains a carry or borrow generated by the arithmetic logic unit (ALU) immediately after an arithmetic operation. It can also be changed by a shift or rotate instruction.
- Bit 1: Zero flag (Z)
 The Z flag is set to "1" if the result of an immediate arithmetic operation or a data transfer is "0", and set to "0" if the result is anything other than "0".
- Bit 2: Interrupt disable flag (I)
 The I flag disables all interrupts except for the interrupt generated by the BRK instruction.
 Interrupts are disabled when the I flag is "1".
- Bit 3: Decimal mode flag (D)
 The D flag determines whether additions and subtractions are executed in binary or decimal. Binary arithmetic is executed when this flag is "0"; decimal arithmetic is executed when it is "1".
 Decimal correction is automatic in decimal mode. Only the ADC and SBC instructions can be used for decimal arithmetic.

- Bit 4: Break flag (B)
 The B flag is used to indicate that the current interrupt was generated by the BRK instruction. When the BRK instruction is generated, the B flag is set to "1" automatically. When the other interrupts are generated, the B flag is set to "0", and the processor status register is pushed onto the stack.
- Bit 5: Index X mode flag (T)
 When the T flag is "0", arithmetic operations are performed between accumulator and memory. When the T flag is "1", direct arithmetic operations and direct data transfers are enabled between memory locations.
- Bit 6: Overflow flag (V)
 The V flag is used during the addition or subtraction of one byte of signed data. It is set if the result exceeds +127 to -128. When the BIT instruction is executed, bit 6 of the memory location operated on by the BIT instruction is stored in the overflow flag.
- Bit 7: Negative flag (N)
 The N flag is set to "1" if the result of an arithmetic operation or data transfer is negative. When the BIT instruction is executed, bit 7 of the memory location operated on by the BIT instruction is stored in the negative flag.

Table 5 Set and clear instructions of each bit of processor status register

	C flag	Z flag	I flag	D flag	B flag	T flag	V flag	N flag
Set instruction	SEC	–	SEI	SED	–	SET	–	–
Clear instruction	CLC	–	CLI	CLD	–	CLT	CLV	–

[CPU Mode Register (CPUM)] 003B₁₆

The CPU mode register contains the stack page selection bit and the control bit for the internal system clock.

The CPU mode register is allocated at address 003B₁₆.

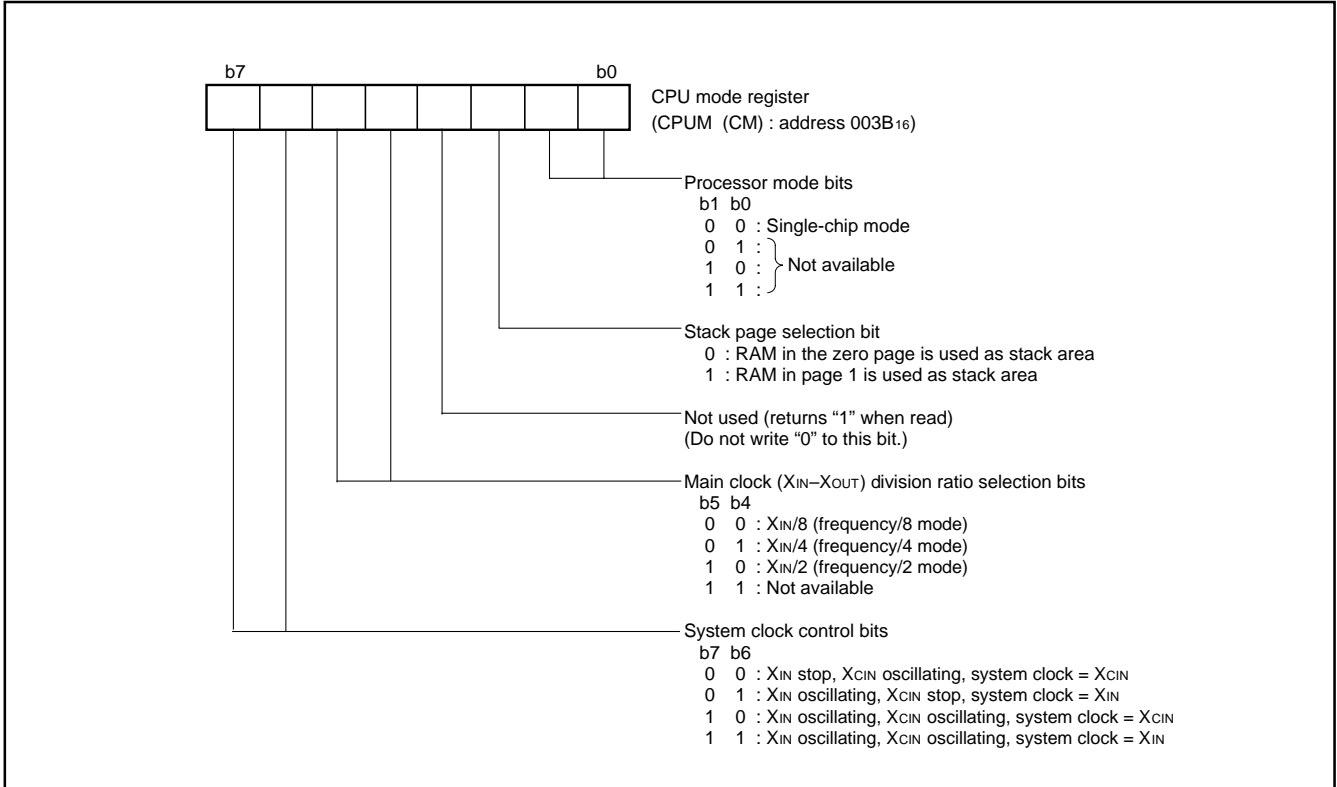

Fig. 7 Structure of CPU mode register

MEMORY

Special Function Register (SFR) Area

The Special Function Register area in the zero page contains control registers such as I/O ports and timers.

RAM

RAM is used for data storage and for stack area of subroutine calls and interrupts.

ROM

The first 128 bytes and the last 2 bytes of ROM are reserved for device testing and the rest is user area for storing programs.

Interrupt Vector Area

The interrupt vector area contains reset and interrupt vectors.

Zero Page

Access to this area with only 2 bytes is possible in the zero page addressing mode.

Special Page

Access to this area with only 2 bytes is possible in the special page addressing mode.

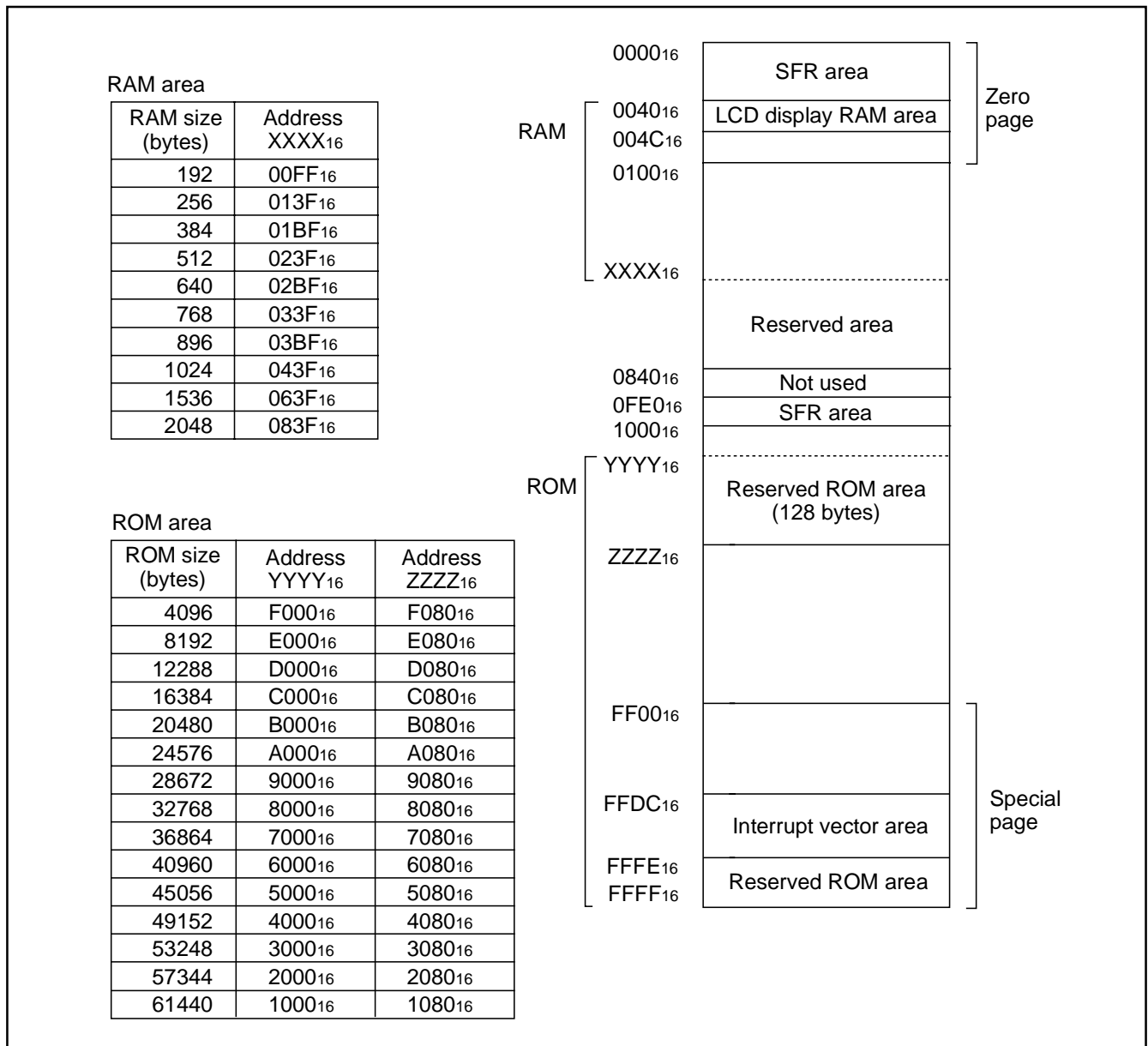

Fig. 8 Memory map diagram

0000 ₁₆	Port P0 (P0)	0020 ₁₆	Timer 1 (T1)
0001 ₁₆	Port P0 direction register (P0D)	0021 ₁₆	Timer 2 (T2)
0002 ₁₆	Port P1 (P1)	0022 ₁₆	Timer 3 (T3)
0003 ₁₆	Port P1 direction register (P1D)	0023 ₁₆	Timer 4 (T4)
0004 ₁₆	Port P2 (P2)	0024 ₁₆	PWM01 register (PWM01)
0005 ₁₆	Port P2 direction register (P2D)	0025 ₁₆	Timer 12 mode register (T12M)
0006 ₁₆	Port P3 (P3)	0026 ₁₆	Timer 34 mode register (T34M)
0007 ₁₆	Port P3 direction register (P3D)	0027 ₁₆	
0008 ₁₆	Port P4 (P4)	0028 ₁₆	Compare register (low-order) (COMPL)
0009 ₁₆	Port P4 direction register (P4D)	0029 ₁₆	Compare register (high-order) (COMPH)
000A ₁₆	Port P5 (P5)	002A ₁₆	Timer X (low-order) (TXL)
000B ₁₆	Port P5 direction register (P5D)	002B ₁₆	Timer X (high-order) (TXH)
000C ₁₆	Port P6 (P6)	002C ₁₆	Timer X (extension) (TXEX)
000D ₁₆	Port P6 direction register (P6D)	002D ₁₆	Timer Y (low-order) (TYL)
000E ₁₆		002E ₁₆	Timer Y (high-order) (TYH)
000F ₁₆		002F ₁₆	Timer X mode register (TXM)
0010 ₁₆		0030 ₁₆	Timer Y mode register (TYM)
0011 ₁₆		0031 ₁₆	
0012 ₁₆		0032 ₁₆	
0013 ₁₆		0033 ₁₆	
0014 ₁₆		0034 ₁₆	
0015 ₁₆		0035 ₁₆	
0016 ₁₆		0036 ₁₆	
0017 ₁₆		0037 ₁₆	Watchdog timer control register (WDTCN)
0018 ₁₆	Clock output control register (CKOUT)	0038 ₁₆	LCD power control register (VLCON)
0019 ₁₆	A-D control register (ADCON)	0039 ₁₆	LCD mode register (LM)
001A ₁₆	A-D conversion register (low-order) (ADL)	003A ₁₆	Interrupt edge selection register (INTEDGE)
001B ₁₆	A-D conversion register (high-order) (ADH)	003B ₁₆	CPU mode register (CPUM)
001C ₁₆	Transmit/receive buffer register 1 (TB1/RB1)	003C ₁₆	Interrupt request register 1 (IREQ1)
001D ₁₆	Serial I/O1 status register (SIO1STS)	003D ₁₆	Interrupt request register 2 (IREQ2)
001E ₁₆	Transmit/receive buffer register 2 (TB2/RB2)	003E ₁₆	Interrupt control register 1 (ICON1)
001F ₁₆	Serial I/O2 status register (SIO2STS)	003F ₁₆	Interrupt control register 2 (ICON2)
0FE0 ₁₆	Serial I/O1 control register (SIO1CON)	0FF0 ₁₆	Oscillation output control register (OSCOU)
0FE1 ₁₆	UART1 control register (UART1CON)	0FF1 ₁₆	PULL register (PULL)
0FE2 ₁₆	Baudrate generator 1 (BRG1)	0FF2 ₁₆	Key input control register (KIC)
0FE3 ₁₆	Serial I/O2 control register (SIO2CON)	0FF3 ₁₆	Timer 1234 mode register (T1234M)
0FE4 ₁₆	UART2 control register (UART2CON)	0FF4 ₁₆	Timer X control register (TXCON)
0FE5 ₁₆	Baudrate generator 2 (BRG2)	0FF5 ₁₆	Timer 12 frequency division selection register (PRE12)
0FE6 ₁₆		0FF6 ₁₆	Timer 34 frequency division selection register (PRE34)
0FE7 ₁₆		0FF7 ₁₆	Timer XY frequency division selection register (PREXY)
0FE8 ₁₆		0FF8 ₁₆	Segment output disable register 0 (SEG0)
0FE9 ₁₆		0FF9 ₁₆	Segment output disable register 1 (SEG1)
0FEA ₁₆		0FFA ₁₆	Segment output disable register 2 (SEG2)
0FEB ₁₆		0FFB ₁₆	Timer Y mode register 2 (TYM2)
0FEC ₁₆		0FFC ₁₆	
0FED ₁₆		0FFD ₁₆	
0FEE ₁₆		0FFE ₁₆	Flash memory control register (FMCR)
0FEF ₁₆		0FFF ₁₆	Reserved area (access disabled)

Fig. 9 Memory map of special function register (SFR)

I/O PORTS

Direction Registers

The I/O ports P0–P6 have direction registers which determine the input/output direction of each individual pin. Each bit in a direction register corresponds to one pin, each pin can be set to be input port or output port.

When “0” is written to the bit of the direction register, the corresponding pin becomes an input pin. As for ports P0–P2, when “1” is written to the bit of the direction register and the segment output disable register, the corresponding pin becomes an output pin. As for ports P3–P6, when “1” is written to the bit of the direction register, the corresponding pin becomes an output pin.

If data is read from a pin set to output, the value of the port latch is read, not the value of the pin itself. Pins set to input are floating. If a pin set to input is written to, only the port output latch is written to and the pin remains floating.

Pull-up Control

Each individual bit of ports P0–P2 can be pulled up with a program by setting direction registers and segment output disable registers 0 to 2 (addresses 0FF816 to 0FFA16).

The pin is pulled up by setting “0” to the direction register and “1” to the segment output disable register.

By setting the PULL register (address 0FF116), ports P3–P6 can control pull-up with a program.

However, the contents of PULL register do not affect ports programmed as the output ports.

	Segment output disable register	“0”	“1”	Initial state
	Direction register	“0”	“1”	
“0”	“0”	Input port No pull-up	Input port Pull-up	
“1”	“1”	Segment output	Port output	

Fig. 10 Structure of ports P0 to P2

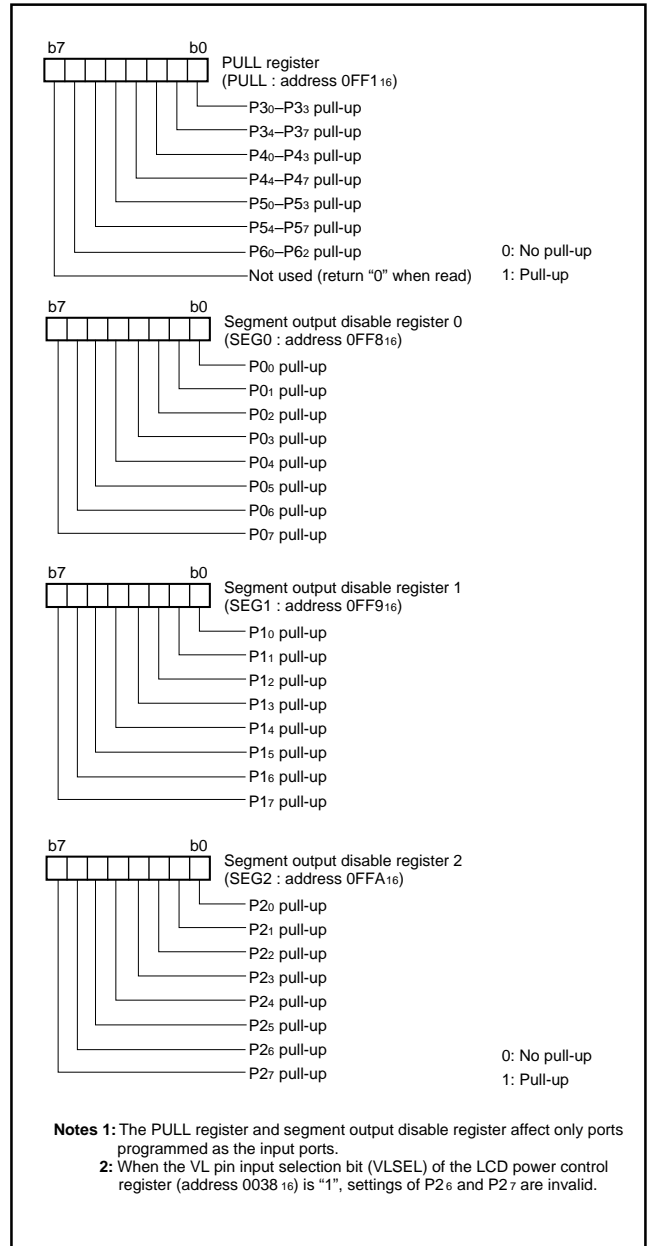

Fig. 11 Structure of PULL register and segment output disable register

Table 6 List of I/O port function

Pin	Name	Input/Output	I/O format	Non-port function		Related SFRs	Ref. No.
P00/SEG0 – P03/SEG3	Port P0	Input/Output, individual bits	CMOS compatible input level CMOS 3-state output	LCD segment output	Key input (key-on wakeup) interrupt input	Segment output disable register 1	(1)
P04/SEG4 – P07/SEG7							(2)
P10/SEG8 – P17/SEG15	Port P1	Input/Output, individual bits	CMOS compatible input level CMOS 3-state output			Segment output disable register 2	
P20/SEG16 – P25/SEG21	Port P2	Input/Output, individual bits	CMOS compatible input level CMOS 3-state output		LCD power input	Segment output disable register 3	
P26/SEG22/VL1 P27/SEG23/VL2							
P30/ $\overline{\text{SRDY}}2$ P31/SCLK2 P32/TxD2 P33/RxD2	Port P3	Input/Output, individual bits	CMOS compatible input level CMOS 3-state output	Serial I/O2 function I/O		PULL register Serial I/O2 control register Serial I/O2 status register UART2 control register	(3) (4) (5) (6)
P34/INT2				External interrupt input		PULL register Interrupt edge selection register	(7)
P35/TxOUT P36/T2OUT/ ϕ				Timer X output Timer 2 output		PULL register Timer X mode register Timer 12 mode register	(8) (9)
				Timer X function input		PULL register Timer X mode register	(7)
P37/CNTR0							
P40/OoUT0/AN0 P41/OoUT1/AN1	Port P4	Input/Output, individual bits	CMOS compatible input level CMOS 3-state output	A-D conversion input	Oscillation external output	PULL register A-D control register	(11)
P42/AN2– P45/AN5							(10)
P46/RTP0/AN6 P47/RTP1/AN7					Real time port function output	PULL register A-D control register Timer Y mode register	(11)
P50/INT0 P51/INT1	Port P5	Input/Output, individual bits	CMOS compatible input level CMOS 3-state output	External interrupt input		PULL register Interrupt edge selection register	(7)
P52/T3OUT/PWM0 P53/T4OUT/PWM1				Timer 3 output Timer 4 output PWM output		PULL register Timer 12 mode register	(9)
				P54/RxD1 P55/TxD1 P56/SCLK1 P57/ $\overline{\text{SRDY}}1$	Serial I/O1 function I/O	Key input (key-on wakeup) interrupt input	PULL register Serial I/O1 control register Serial I/O1 status register UART1 control register
P60/CNTR1	Port P6	Input/Output, individual bits	CMOS compatible input level CMOS 3-state output	Timer Y function input		PULL register Timer Y mode register	(7)
P61/XCIN				Sub-clock oscillation circuit		PULL register	(16)
P62/XCOUT						CPU mode register	(17)
COM0–COM3	Common	Output	LCD common output			LCD mode register	(18)

Notes 1: For details of how to use double/triple function ports as function I/O ports, refer to the applicable sections.

2: Make sure that the input level at each pin is either 0 V or VCC during execution of the STP instruction.

When an input level is at an intermediate potential, a current will flow from Vcc to Vss through the input-stage gate.

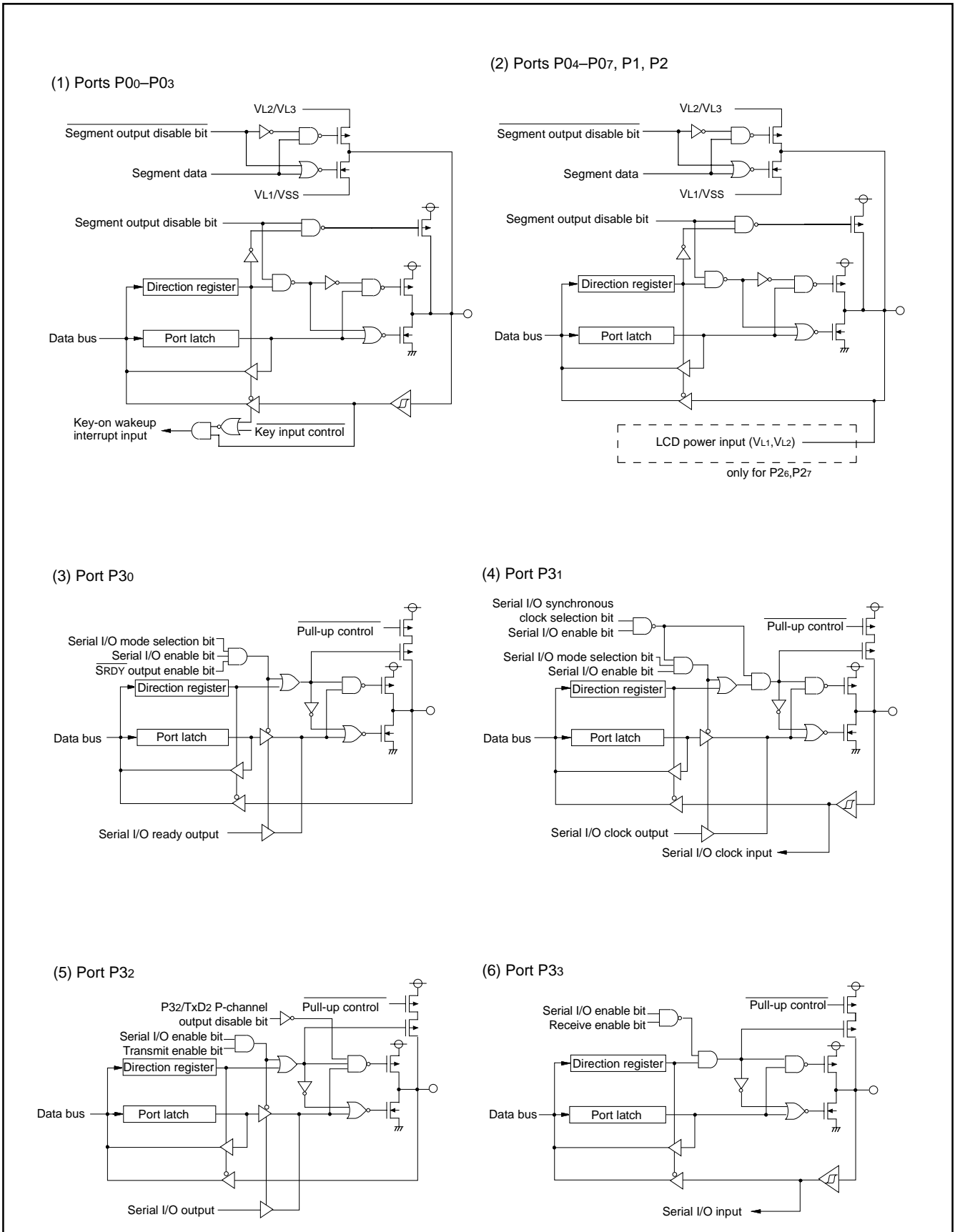

Fig. 12 Port block diagram (1)

PRELIMINARY
 Notice: This is not a final specification.
 Some parametric limits are subject to change.

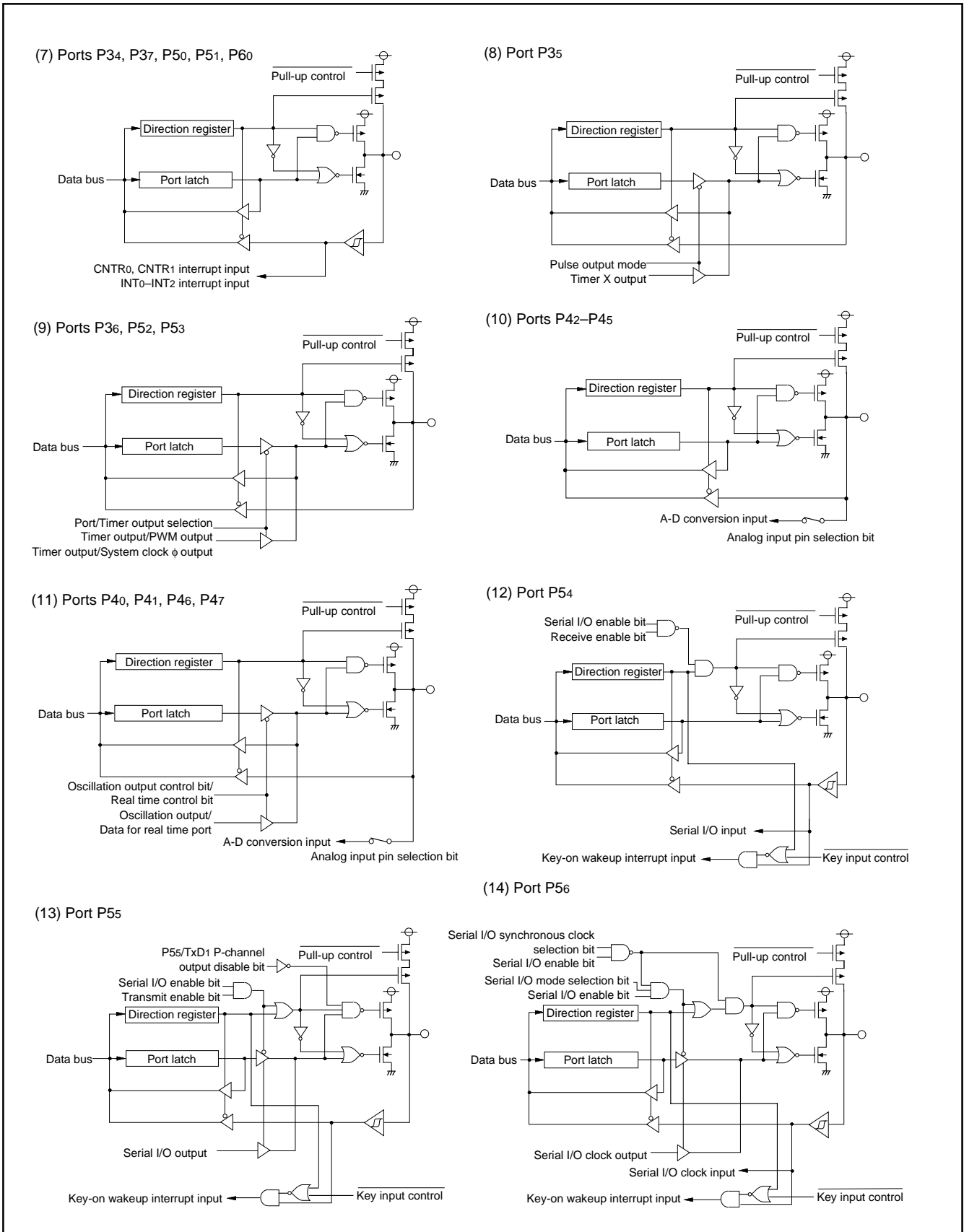

Fig. 13 Port block diagram (2)

PRELIMINARY
 Notice: This is not a final specification.
 Some parametric limits are subject to change.

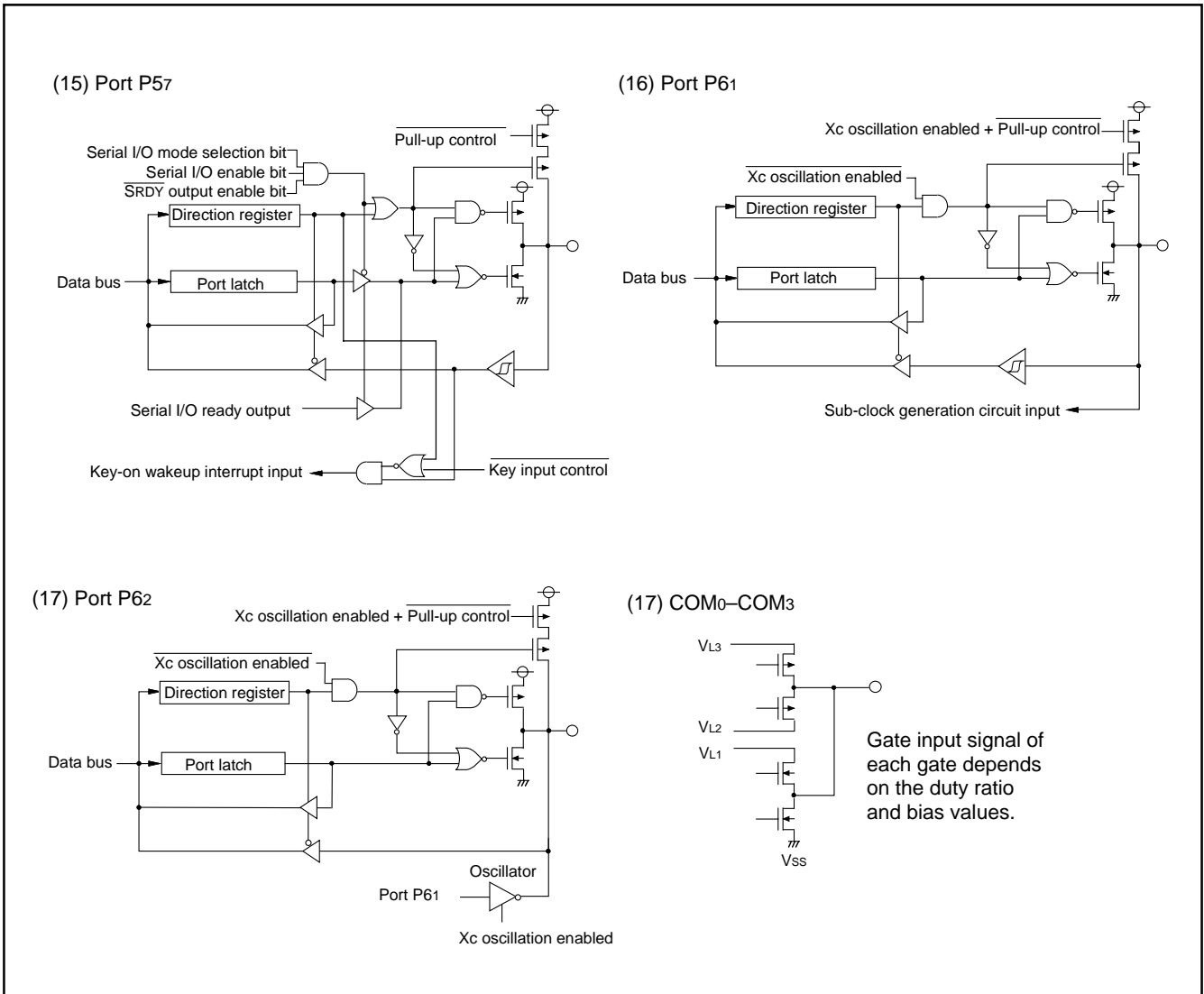

Fig. 14 Port block diagram (3)

INTERRUPTS

Interrupts occur by nineteen sources: six external, twelve internal, and one software.

Interrupt Control

Each interrupt except the BRK instruction interrupt have both an interrupt request bit and an interrupt enable bit, and is controlled by the interrupt disable flag. An interrupt occurs if the corresponding interrupt request and enable bits are "1" and the interrupt disable flag is "0".

Interrupt enable bits can be set or cleared by program. Interrupt request bits can be cleared by program, but cannot be set by software. The BRK instruction interrupt and reset cannot be disabled with any flag or bit. The I flag disables all interrupts except the BRK instruction interrupt and reset. If several interrupt requests occur at the same time, the interrupt with highest priority is accepted first.

Interrupt Operation

By acceptance of an interrupt, the following operations are automatically performed:

1. The contents of the program counter and processor status register are automatically pushed onto the stack.
2. The interrupt disable flag is set to "1" and the corresponding interrupt request bit is set to "0".

3. The interrupt jump destination address is read from the vector table into the program counter.

■ Notes on Interrupts

When setting the followings, the interrupt request bit may be set to "1".

- When switching external interrupt active edge
 Related register: Interrupt edge selection register (address 3A₁₆)
 Timer X control register (address FF4₁₆)
 Timer Y mode register (address 30₁₆)
- When switching interrupt sources of an interrupt vector address where two or more interrupt sources are allocated
 Related register: Interrupt edge selection register (address 3A₁₆)
 When not requiring the interrupt occurrence synchronous with these setting, take the following sequence.
 - ①Set the corresponding interrupt enable bit to "0" (disabled).
 - ②Set the interrupt edge select bit (polarity switch bit) or the interrupt source selection bit.
 - ③Set the corresponding interrupt request bit to "0" after 1 or more instructions have been executed.
 - ④Set the corresponding interrupt enable bit to "1" (enabled).

Table 7 Interrupt vector addresses and priority

Interrupt Source	Priority	Vector Addresses (Note 1)		Interrupt Request Generating Conditions	Remarks
		High	Low		
Reset (Note 2)	1	FFFD ₁₆	FFFC ₁₆	At reset	Non-maskable
INT ₀	2	FFFB ₁₆	FFFA ₁₆	At detection of either rising or falling edge of INT ₀ input	External interrupt (active edge selectable)
INT ₁	3	FFF9 ₁₆	FFF8 ₁₆	At detection of either rising or falling edge of INT ₁ input	External interrupt (active edge selectable)
INT ₂	4	FFF7 ₁₆	FFF6 ₁₆	At detection of either rising or falling edge of INT ₂ input	Valid when INT ₂ interrupt is selected External interrupt (active edge selectable)
Key input (key-on wakeup)				At falling of ports P ₀₀ –P ₀₃ , P ₅₄ –P ₅₇ input logical level AND	Valid when key input interrupt is selected External interrupt (falling valid)
Serial I/O ₁ receive	5	FFF5 ₁₆	FFF4 ₁₆	At completion of serial I/O ₁ data receive	Valid only when serial I/O ₁ is selected
Serial I/O ₁ transmit	6	FFF3 ₁₆	FFF2 ₁₆	At completion of serial I/O ₁ transmit shift or transmit buffer is empty	Valid only when serial I/O ₁ is selected
Serial I/O ₂ receive	7	FFF1 ₁₆	FFF0 ₁₆	At completion of serial I/O ₂ data receive	Valid only when serial I/O ₂ is selected
Serial I/O ₂ transmit	8	FFE _F ₁₆	FFE _E ₁₆	At completion of serial I/O ₂ transmit shift or transmit buffer is empty	Valid only when serial I/O ₂ is selected
Timer X	9	FFED ₁₆	FFEC ₁₆	At timer X underflow	
Timer 1	10	FFEB ₁₆	FFEA ₁₆	At timer 1 underflow	Valid only when timer 1 interrupt is selected
Timer 2	11	FFE9 ₁₆	FFE8 ₁₆	At timer 2 underflow	Valid only when timer 2 interrupt is selected
Timer 3	12	FFE7 ₁₆	FFE6 ₁₆	At timer 3 underflow	
Timer 4	13	FFE5 ₁₆	FFE4 ₁₆	At timer 4 underflow	
CNTR ₀	14	FFE3 ₁₆	FFE2 ₁₆	At detection of either rising or falling edge of CNTR ₀ input	External interrupt (active edge selectable)
Timer Y CNTR ₁	15	FFE1 ₁₆	FFE0 ₁₆	At timer Y underflow At detection of either rising or falling edge of CNTR ₁ input	External interrupt (active edge selectable)
A-D conversion	16	FFDF ₁₆	FFDE ₁₆	At completion of A-D conversion	Valid when A-D conversion interrupt is selected
BRK instruction	17	FFDD ₁₆	FFDC ₁₆	At BRK instruction execution	Non-maskable software interrupt

Notes 1: Vector addresses contain interrupt jump destination addresses.

2: Reset function in the same way as an interrupt with the highest priority.

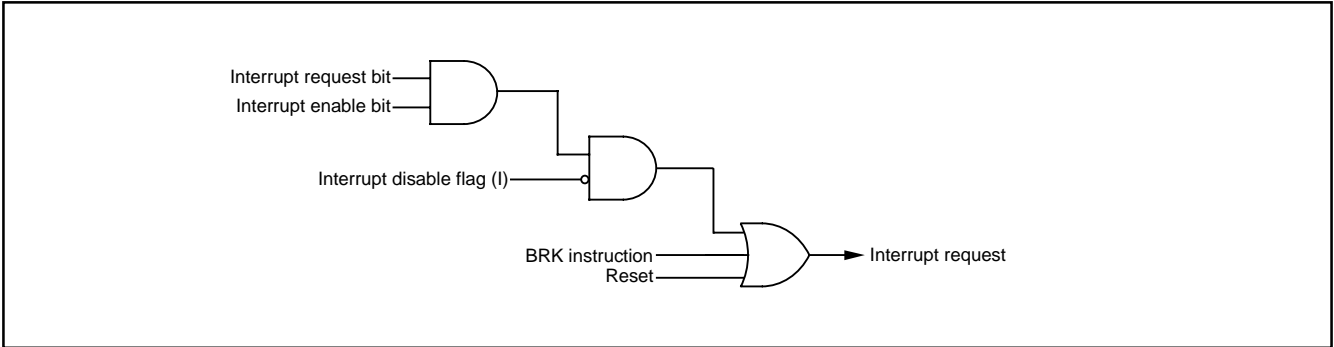

Fig. 15 Interrupt control

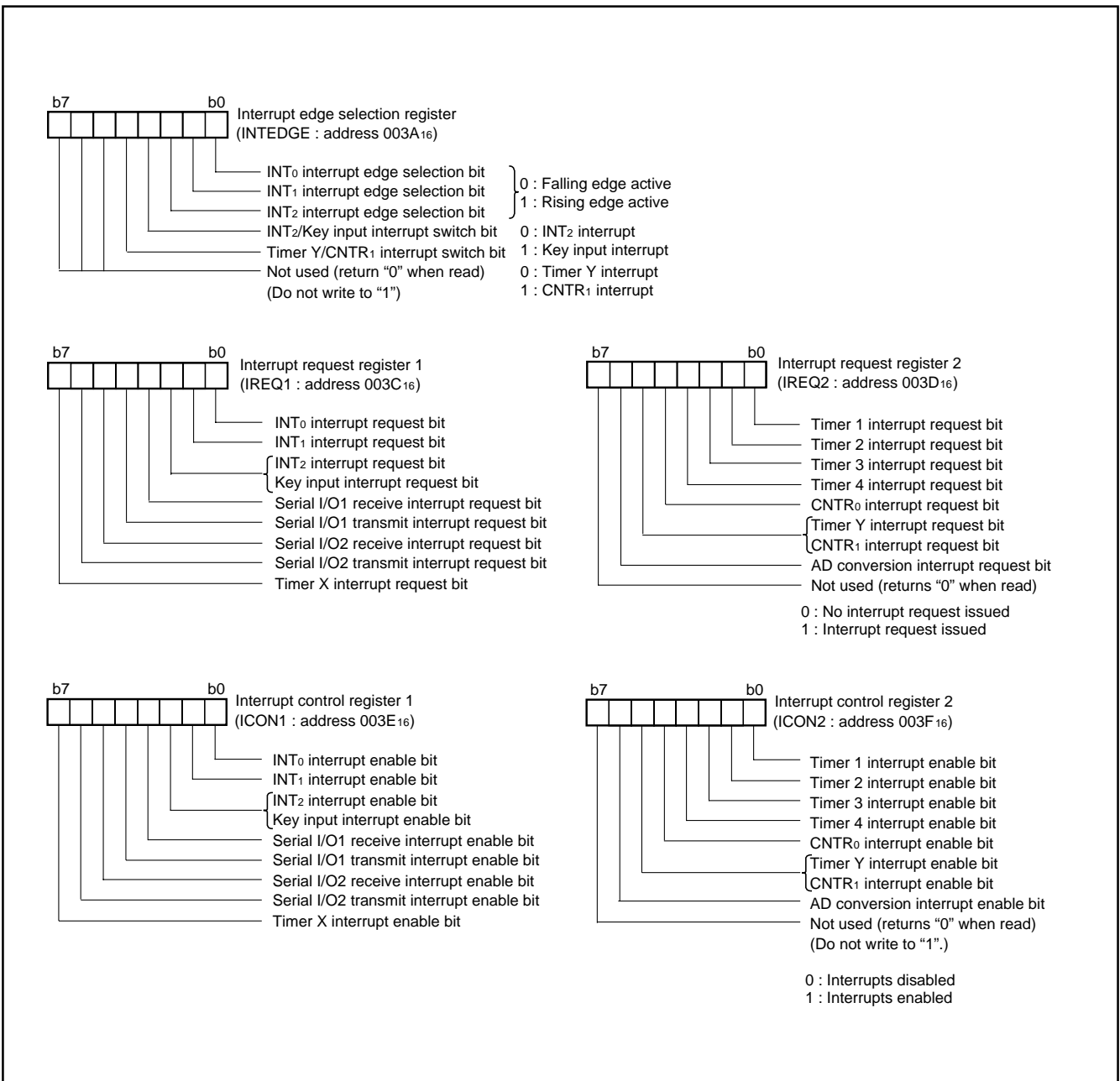

Fig. 16 Structure of interrupt-related registers

Key Input Interrupt (Key-on Wake-Up)

A key input interrupt request is generated by detecting the falling edge from any pin of ports P00–P03, P54–P57 that have been set to input mode. In other words, it is generated when AND of input level

goes from "1" to "0". An example of using a key input interrupt is shown in Figure 17, where an interrupt request is generated by pressing one of the keys consisted as an active-low key matrix which inputs to ports P54–P57.

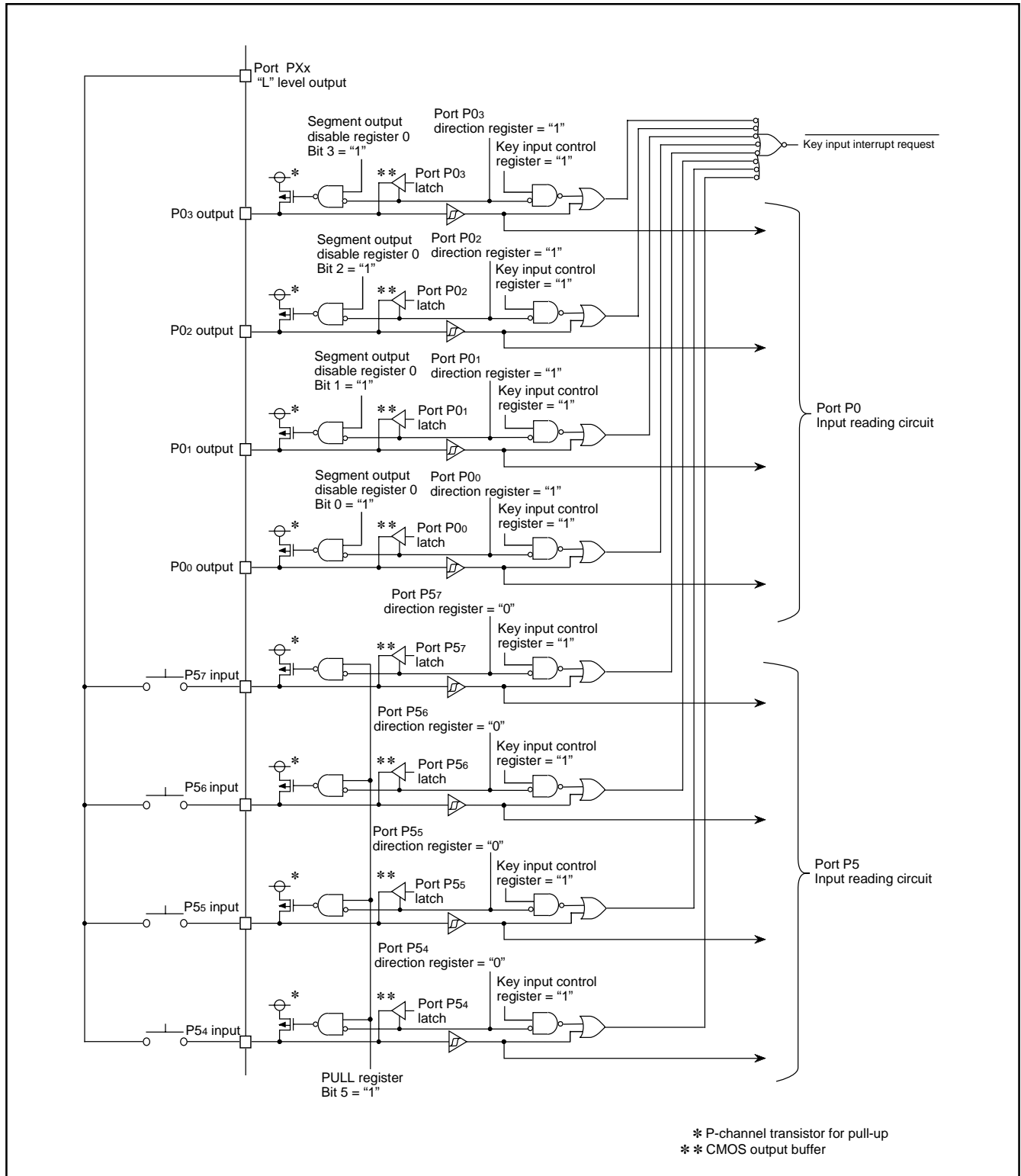

Fig. 17 Connection example when using key input interrupt and ports P0 and P5 block diagram

A key input interrupt is controlled by the key input control register and port direction registers. When the key input interrupt is enabled, set "1" to the key input control register. A key input of any pin of ports P0₀–P0₃, P5₄–P5₇ that have been set to input mode is accepted.

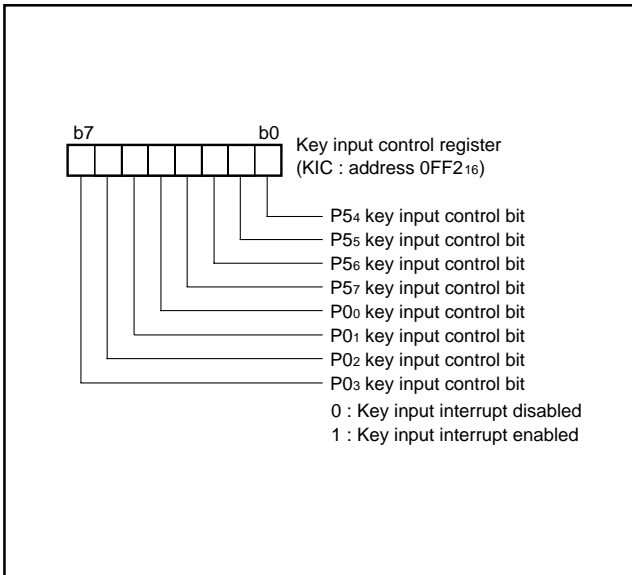

Fig. 18 Structure of key input control register

TIMERS

8-Bit Timer

The 38C2 group has four built-in timers : Timer 1, Timer 2, Timer 3, and Timer 4.

Each timer has the 8-bit timer latch. All timers are down-counters. When the timer reaches "0016", the contents of the timer latch is reloaded into the timer with the next count pulse. In this mode, the interrupt request bit corresponding to that timer is set to "1".

The count can be stopped by setting the stop bit of each timer to "1".

● Frequency Divider For Timer

Timer 1, timer 2, timer 3 and timer 4 have the frequency divider for the count source. The count source of the frequency divider is switched to XIN or XCIN by the CPU mode register. The frequency divider is controlled by each timer division ratio selection bit. The division ratio can be selected from as follows;

1/1, 1/2, 1/16, 1/32, 1/64, 1/128, 1/256, 1/1024 of f(XIN); or f(XCIN).

● Timer 1, Timer 2

The count sources of timer 1 and timer 2 can be selected by setting the timer 12 mode register.

When f(XCIN) is selected as the count source, counting can be performed regardless of XCIN oscillation. However, when XCIN is stopped, the external pulse input from XCIN pin is counted. Also, by the timer 12 mode register, each time timer 2 underflows, the signal of which polarity is inverted can be output from P36/T2OUT pin.

At reset, all bits of the timer 12 mode register are set to "0," timer 1 is set to "FF16", and timer 2 is set to "0116".

When executing the STP instruction, previously set the wait time at return.

● Timer 3, Timer 4

The count sources of timer 3 and timer 4 can be selected by setting the timer 34 mode register. Also, by the timer 34 mode register, each time timer 3 or timer 4 underflows, the signal of which polarity is inverted can be output from P52/T3OUT pin or P53/T4OUT pin.

● Timer 3 PWM0 Mode, Timer 4 PWM1 Mode

A PWM rectangular waveform corresponding to the 10-bit accuracy can be output from the P52/PWM0 pin and P53/PWM1 pin by setting the timer 34 mode register and PWM01 register (refer to Figure 21).

One output pulse is the short interval. Four output pulses are the long interval. The "n" is the value set in the timer 3 (address 002216) or the timer 4 (address 002316). The "ts" is one period of timer 3 or timer 4 count source. "H" width of the short interval is obtained by n X ts.

However, in the long interval, "H" width of output pulse is extended for ts which is set by the PWM01 register (address 002416).

■ Notes on Timer 3 PWM0 Mode, Timer 4 PWM1 Mode

●When PWM output is suspended after starting PWM output, depending on the level of the output pulse at that time to resume an output, the delay of the one section of the short interval may be needed.

Stop at "H": No output delay

Stop at "L": Output is delayed time of 256 X ts

●In the PWM mode, the follows are performed every cycle of the long interval (4 X 256 X ts).

•Generation of timer 3, timer 4 interrupt requests

•Update of timer 3, timer 4

■ Writing to Timer 2, Timer 3, Timer 4

When writing to the latch only, if the write timing to the reload latch and the underflow timing are almost the same, the value is set into the timer and the timer latch at the same time. In this time, counting is stopped during writing to the reload latch.

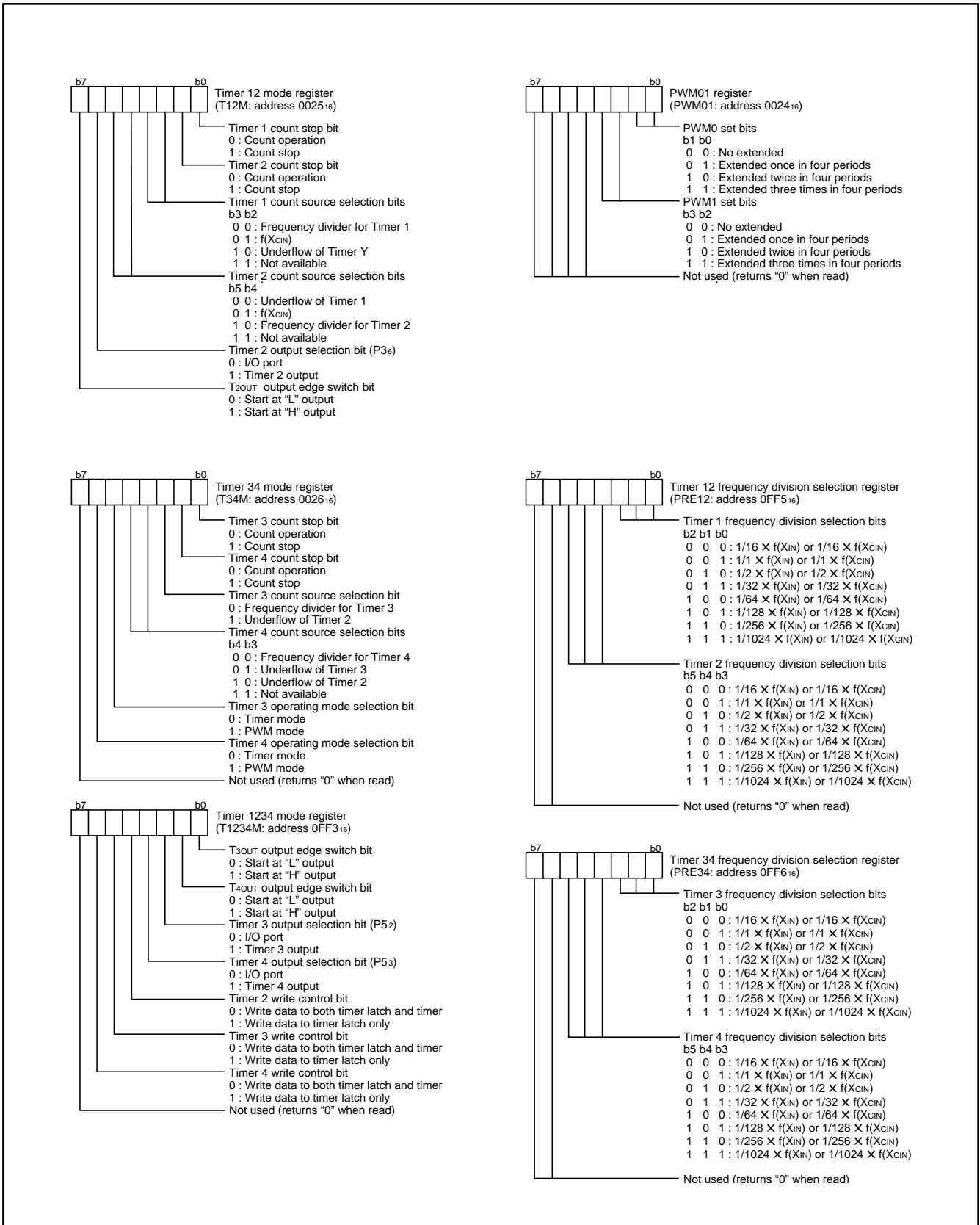

Fig. 19 Structure of timer related register

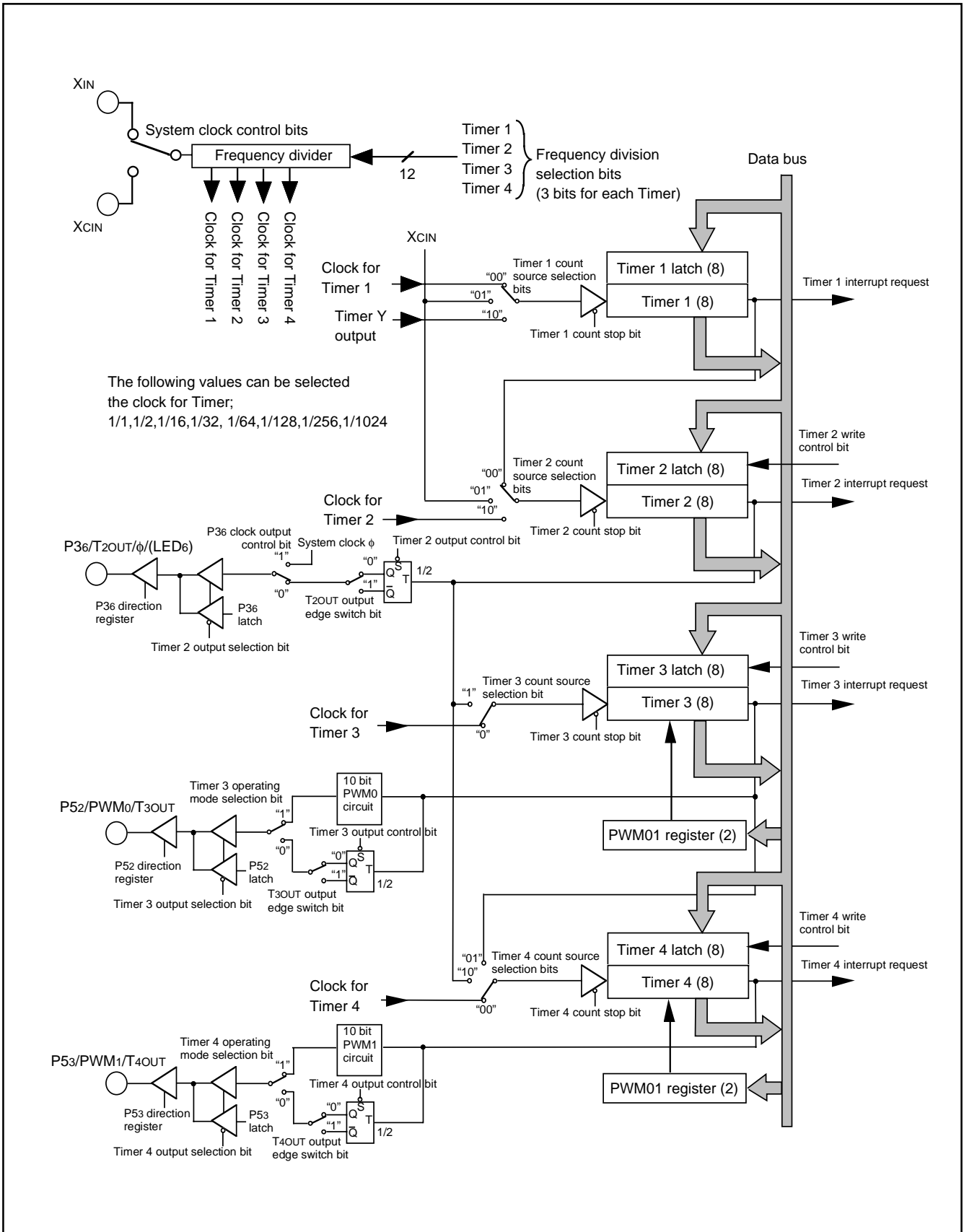

Fig. 20 Block diagram of timers 1, 2, 3 and 4

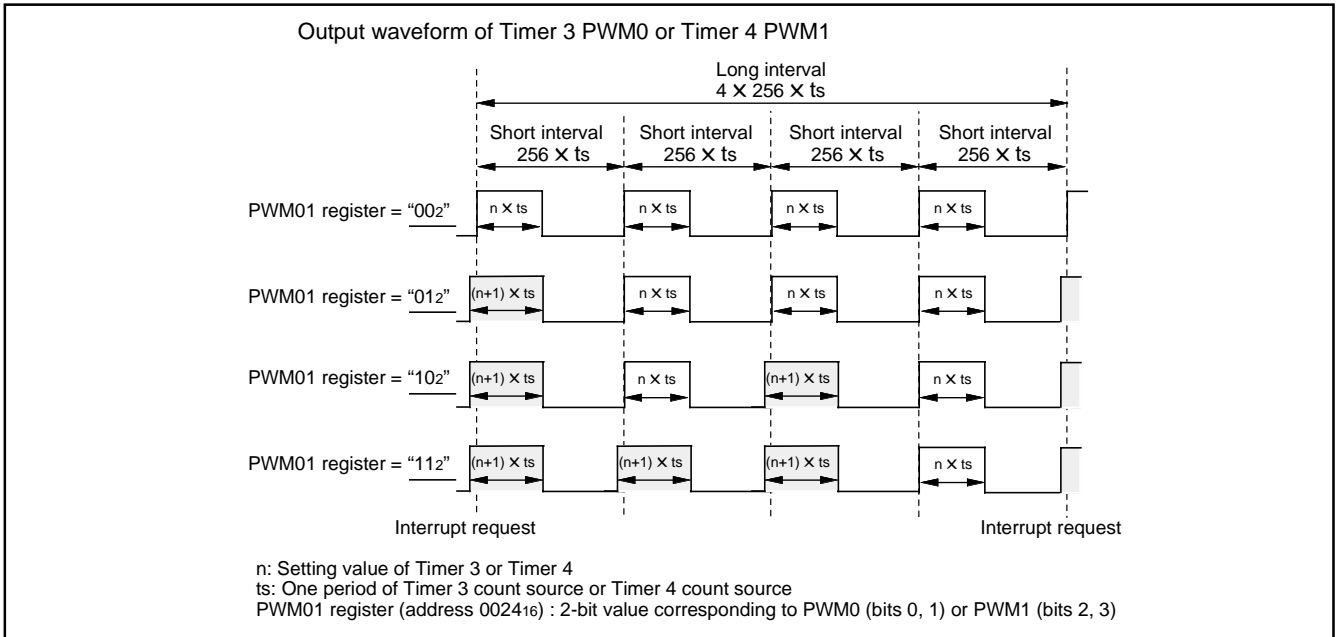

Fig. 21 Waveform of PWM0 and PWM1

16-bit Timer

● Frequency Divider For Timer

Each timer X and timer Y have the frequency dividers for the count source. The count source of the frequency divider is switched to XIN or XCIN by the CPU mode register. The division ratio of each timer can be controlled by each timer division ratio selection bit. The division ratio can be selected from as follows;

1/1, 1/2, 1/16, 1/32, 1/64, 1/128, 1/256, 1/1024 of $f(XIN)$; or $f(XCIN)$.

● Timer X

The timer X count source can be selected by setting the timer X mode register. When $f(XCIN)$ is selected as the count source, counting can be performed regardless of XCIN oscillation. However, when XCIN is stopped, the external pulse input from XCIN pin is counted.

The timer X operates as down-count. When the timer contents reach "000016", an underflow occurs at the next count pulse and the timer latch contents are reloaded. After that, the timer continues count-down. When the timer underflows, the interrupt request bit corresponding to the timer X is set to "1".

Six operating modes can be selected for timer X by the timer X mode register and timer X control register.

(1) Timer Mode

The count source can be selected by setting the timer X mode register. In this mode, timer X operates as the 18-bit counter by setting the timer X register (extension).

(2) Pulse Output Mode

Pulses of which polarity is inverted each time the timer underflows are output from the TXOUT pin. Except for that, this mode operates just as in the timer mode.

When using this mode, set the port sharing the TXOUT pin to output mode.

(3) IGBT Output Mode

After dummy output from the TXOUT pin, count starts with the INT0 pin input as a trigger. In the case that the timer X output edge switch bit is "0", when the trigger is detected or the timer X underflows, "H" is output from the TXOUT pin. And then, when the count value corresponds with the compare register value, the TXOUT output becomes "L".

After noise is cleared by noise filters, judging continuous 4-time same levels with sampling clocks to be signals, the INT0 signal can use 4 types of delay time by a delay circuit.

When using this mode, set the port sharing the INT0 pin to input mode and set the port sharing the TXOUT pin to output mode.

When the timer X output control bit 1 or 2 of the timer X control register is set to "1", the timer X count stop bit is fixed to "1" forcibly by the interrupt signal of INT1 or INT2. And then, the TXOUT output can be set to "L" forcibly at the same time that the timer X stops counting. Do not write "1" to the timer X register (extension) when using the IGBT output mode.

(4) PWM Mode

IGBT dummy output, an external trigger with the INT0 pin and output control with pins INT1 and INT2 are not used. Except for those, this mode operates just as in the IGBT output mode.

The period of PWM waveform is specified by the timer X set value. In the case that the timer X output edge switch bit is "0", the "H" interval is specified by the compare register set value.

When using this mode, set the port sharing the TXOUT pin to output mode.

Do not write "1" to the timer X register (extension) when using the PWM mode.

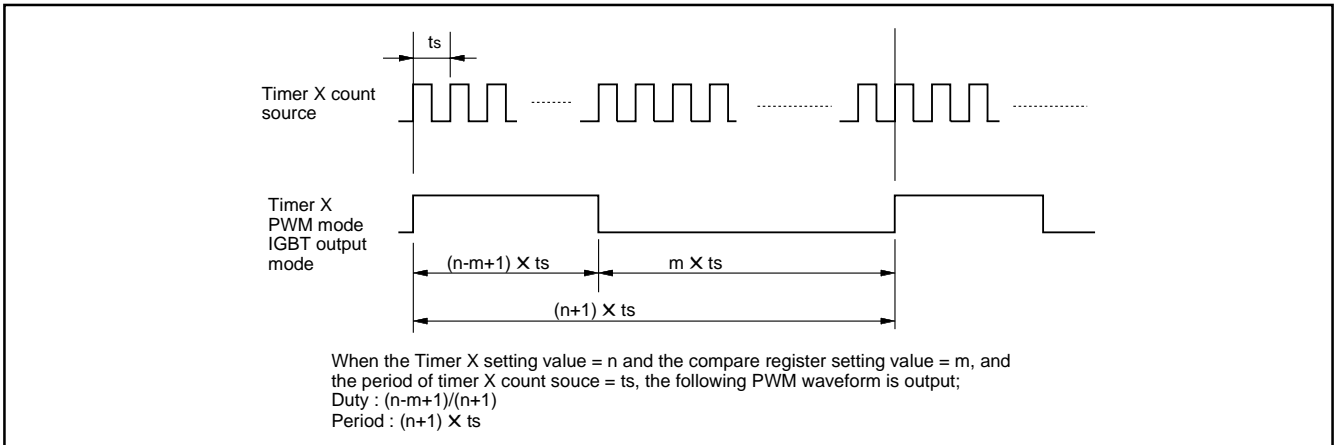

Fig. 22 Waveform of PWM/IGBT

(5) Event Counter Mode

The timer counts signals input through the CNTR0 pin. In this mode, timer X operates as the 18-bit counter by setting the timer X register (extension). When using this mode, set the port sharing the CNTR0 pin to input mode.

In this mode, the window control can be performed by the timer 1 underflow. When the bit 5 (data for control of event counter window) of the timer X mode register is set to "1", counting is stopped at the next timer 1 underflow. When the bit is set to "0", counting is re-started at the next timer 1 underflow.

(6) Pulse Width Measurement Mode

In this mode, the count source is the output of frequency divider for timer. In this mode, timer X operates as the 18-bit counter by setting the timer X register (extension). When the bit 6 of the CNTR0 active edge switch bits is "0", counting is executed during the "H" interval of CNTR0 pin input. When the bit is "1", counting is executed during the "L" interval of CNTR0 pin input. When using this mode, set the port sharing the CNTR0 pin to input mode.

■ Notes on Timer X

(1) Write Order to Timer X

- In the timer mode, pulse output mode, event counter mode and pulse width measurement mode, write to the following registers in the order as shown below;

the timer X register (extension),
 the timer X register (low-order),
 the timer X register (high-order).

Do not write to only one of them.

When the above mode is set and timer X operates as the 16-bit counter, if the timer X register (extension) is never set after reset is released, setting the timer X register (extension) is not required. In this case, write the timer X register (low-order) first and the timer X register (high-order). However, once writing to the timer X register (extension) is executed, note that the value is retained to the reload latch.

- In the IGBT output and PWM modes, do not write "1" to the timer X register (extension). Also, when "1" is already written to the timer X register, be sure to write "0" to the register before using.

Write to the following registers in the order as shown below;

the compare register (high- and low-order),
 the timer X register (extension),
 the timer X register (low-order),
 the timer X register (high-order).

It is possible to use whichever order to write to the compare register (high- and low-order). However, write both the compare register and the timer X register at the same time.

(2) Read Order to Timer X

- In all modes, read the following registers in the order as shown below;
 the timer X register (extension),
 the timer X register (high-order),
 the timer X register (low-order).

When reading the timer X register (extension) is not required, read the timer X register (high-order) first and the timer X register (low-order).

Read order to the compare register is not specified.

- If reading to the timer X register during write operation or writing to it during read operation is performed, normal operation will not be performed.

(3) Write to Timer X

- Which write control can be selected by the timer X write control bit (b3) of the timer X mode register (address 2F16), writing data to both the latch and the timer at the same time or writing data only to the latch. When writing a value to the timer X address to write to the latch only, the value is set into the reload latch and the timer is updated at the next underflow. After reset release, when writing a value to the timer X address, the value is set into the timer and the timer latch at the same time, because they are written at the same time.

When writing to the latch only, if the write timing to the high-order reload latch and the underflow timing are almost the same, the value is set into the timer and the timer latch at the same time. In this time, counting is stopped during writing to the high-order reload latch.

- Do not switch the timer count source during timer count operation. Stop the timer count before switching it.

(4) Set of Timer X Mode Register

Set the write control bit of the timer X mode register to "1" (write to the latch only) when setting the IGBT output and PWM modes. Output waveform simultaneously reflects the contents of both registers at the next underflow after writing to the timer X register (high-order).

(5) Output Control Function of Timer X

- When using the output control function (INT1 and INT2) in the IGBT output mode, set the levels of INT1 and INT2 to "H" in the falling edge active or to "L" in the rising edge active before switching to the IGBT output mode.
- Set the level of INT0 to "H" in the falling edge active or to "L" in the rising edge active before switching to the IGBT output mode.

(6) Note on Switch of CNTR0 Active Edge

- When the CNTR0 active edge switch bits are set, at the same time, the interrupt active edge is also affected.
- When the pulse width is measured, set the bit 7 of the CNTR0 active edge switch bits to "0".

Timer Y

Timer Y is a 16-bit timer. The timer Y count source can be selected by setting the timer Y mode register. When f(XCIN) is selected as the count source, counting can be performed regardless of XCIN oscillation. However, when XCIN is stopped, the external pulse input from XCIN pin is counted.

Four operating modes can be selected for timer Y by the timer Y mode register. Also, the real time port can be controlled.

(1) Timer Mode

The timer Y count source can be selected by setting the timer Y mode register.

(2) Period Measurement Mode

The interrupt request is generated at rising or falling edge of CNTR1 pin input signal. Simultaneously, the value in timer Y latch is reloaded in timer Y and timer Y continues counting. Except for that, this mode operates just as in the timer mode.

The timer value just before the reloading at rising or falling of CNTR1 pin input is retained until the timer Y is read once after the reload.

The rising or falling timing of CNTR1 pin input is found by CNTR1 interrupt. When using this mode, set the port sharing the CNTR1 pin to input mode.

(3) Event Counter Mode

The timer counts signals input through the CNTR1 pin.

Except for that, this mode operates just as in the timer mode.

When using this mode, set the port sharing the CNTR1 pin to input mode.

(4) Pulse Width HL Continuously Measurement Mode

The interrupt request is generated at both rising and falling edges of CNTR1 pin input signal. Except for that, this mode operates just as in the period measurement mode. When using this mode, set the port sharing the CNTR1 pin to input mode.

■ Notes on Timer Y

● CNTR1 Interrupt Active Edge Selection

CNTR1 interrupt active edge depends on the CNTR1 active edge switch bit. However, in pulse width HL continuously measurement mode, CNTR1 interrupt request is generated at both rising and falling edges of CNTR1 pin input signal regardless of the setting of CNTR1 active edge switch bit.

● Timer Y Read/Write Control

- When reading from/writing to timer Y, read from/write to both the high-order and low-order bytes of timer Y. When the value is read, read the high-order bytes first and the low-order bytes next. When the value is written, write the low-order bytes first and the high-order bytes next.

If reading from the timer Y register during write operation or writing to it during read operation is performed, normal operation will not be performed.

- When writing a value to the timer Y address to write to the latch only, the value is set into the reload latch and the timer is updated at the next underflow. Normally, when writing a value to the timer Y address, the value is set into the timer and the timer latch at the same time, because they are set to write at the same time. When writing to the latch only, if the write timing to the high-order reload latch and the underflow timing are almost the same, the value is set into the timer and the timer latch at the same time. In this time, counting is stopped during writing to the high-order reload latch.
- Do not switch the timer count source during timer count operation. Stop the timer count before switching it.

● Real Time Port Control

When the real time port function is valid, data for the real time port is output from ports P47 and P46 each time the timer Y underflows. (However, if the real time port control bit is changed from "0" to "1" after the data for real time port is set, data is output independent of the timer Y operation.) When the data for the real time port is changed while the real time port function is valid, the changed data is output at the next underflow of timer Y. Before using this function, set the corresponding port direction registers to output mode.

PRELIMINARY
 Notice: This is not a final specification.
 Some parametric limits are subject to change.

MITSUBISHI MICROCOMPUTERS

38C2 Group (A Version)

SINGLE-CHIP 8-BIT CMOS MICROCOMPUTER

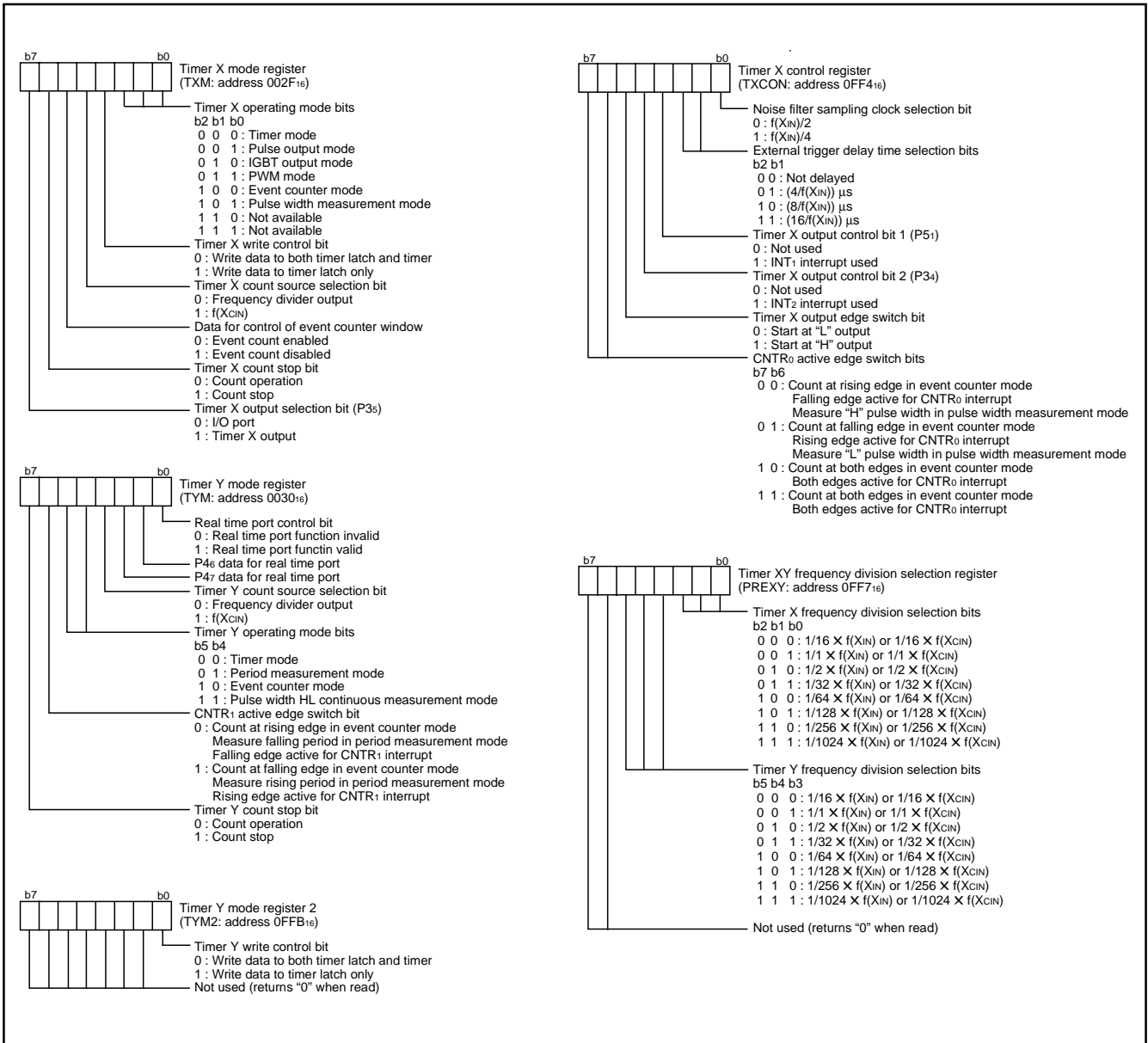

Fig. 23 Structure of Timer X, Y related registers

PRELIMINARY
 Notice: This is not a final specification.
 Some parametric limits are subject to change.

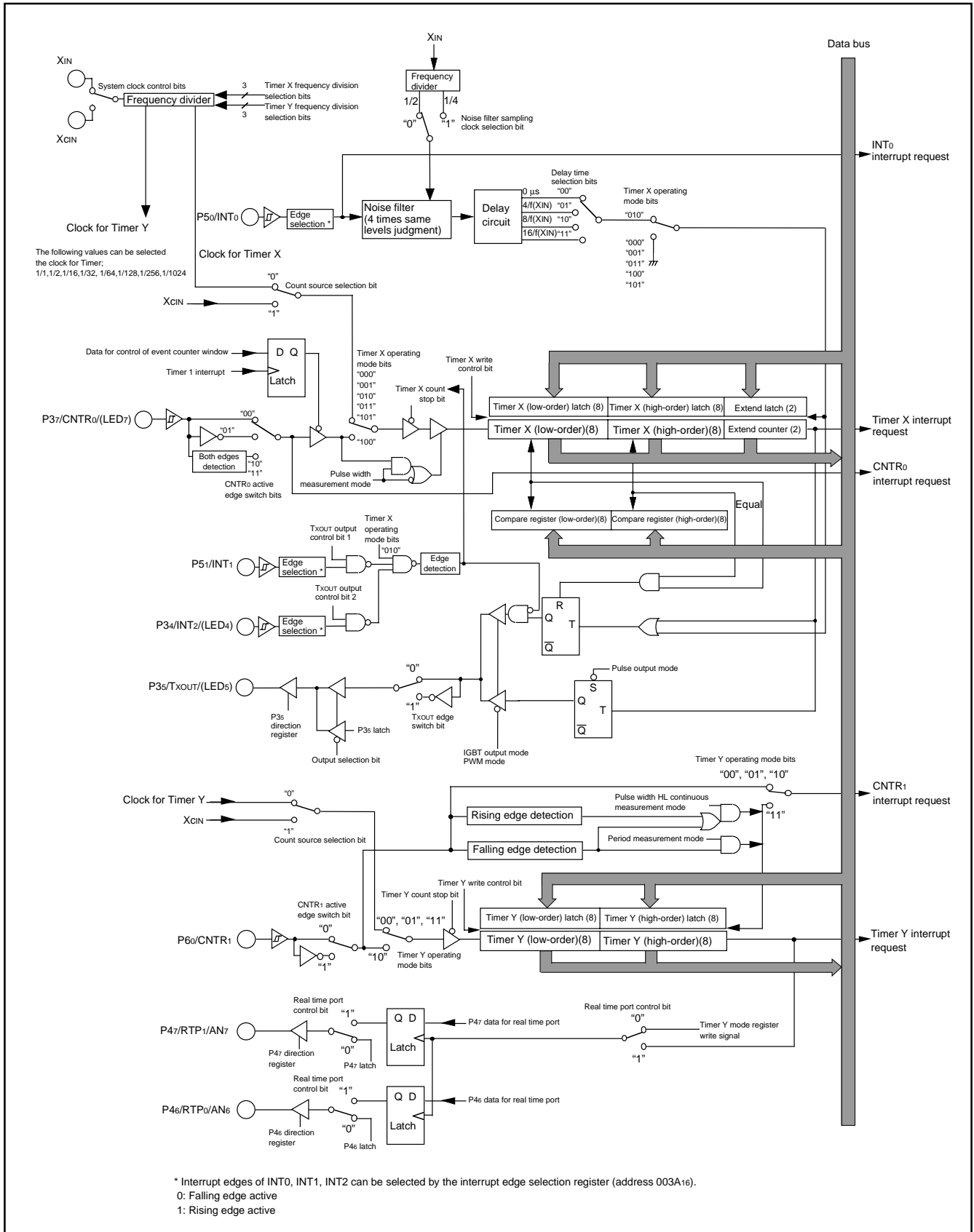

Fig. 24 Block diagram of Timer X, Y

SERIAL I/O

The 38C2 group has built-in two 8-bit serial I/O. Serial I/O can be used as either clock synchronous or asynchronous (UART) serial I/O. A dedicated timer is also provided for baud rate generation.

(1) Clock Synchronous Serial I/O Mode

Clock synchronous serial I/O mode can be selected by setting the serial I/O mode selection bit of the serial I/O control register to "1". For clock synchronous serial I/O, the transmitter and the receiver must use the same clock. If an internal clock is used, transfer is started by a write signal to the TB/RB.

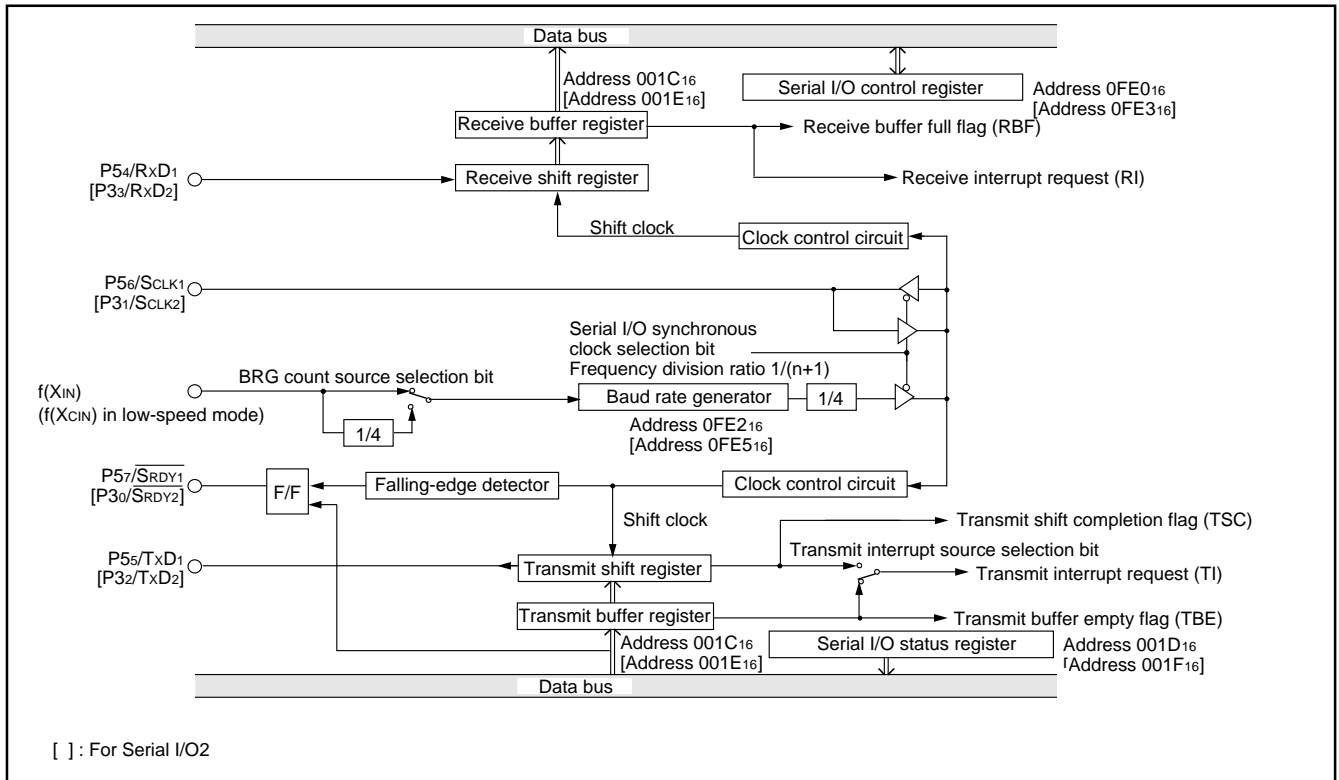

Fig. 25 Block diagram of clock synchronous serial I/O

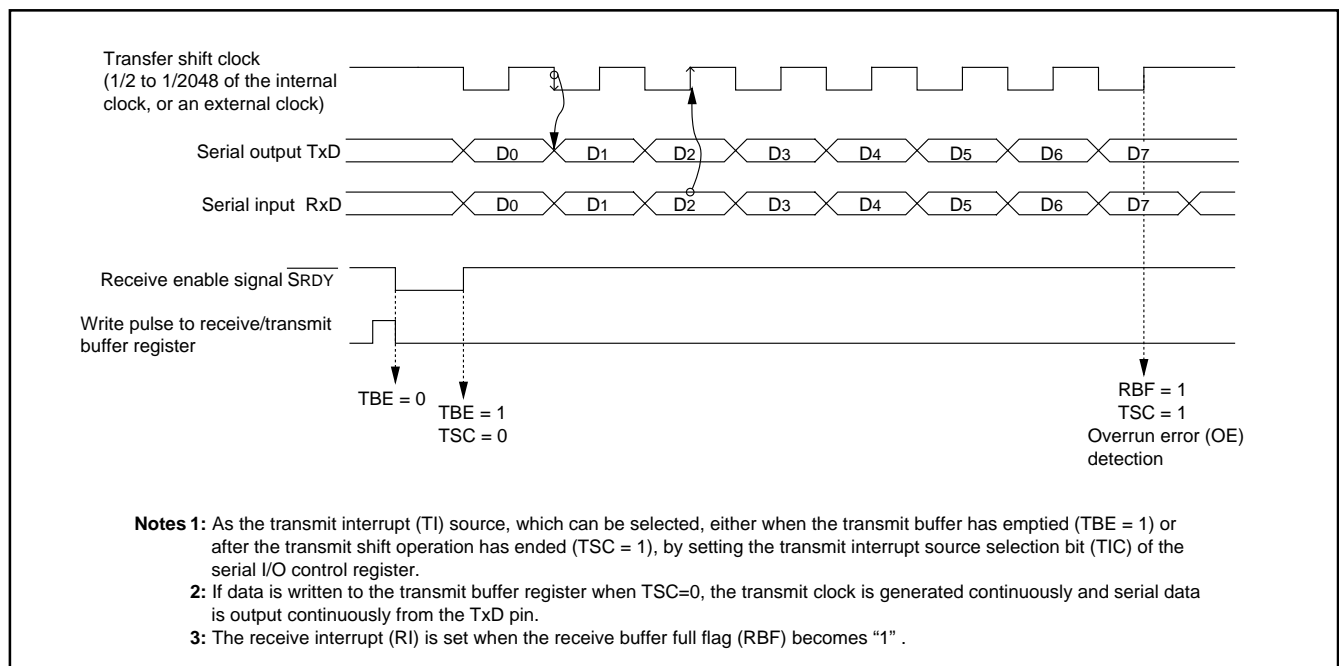

Fig. 26 Operation of clock synchronous serial I/O function

(2) Asynchronous Serial I/O (UART) Mode

Clock asynchronous serial I/O mode (UART) can be selected by setting the serial I/O mode selection bit of the serial I/O control register to "0".

Eight serial data transfer formats can be selected, and the transfer formats used by a transmitter and receiver must be identical.

The transmit and receive shift registers each have a buffer, but the

two buffers have the same address in memory. Since the shift register cannot be written to or read from directly, transmit data is written to the transmit buffer register, and receive data is read from the receive buffer register.

The transmit buffer register can also hold the next data to be transmitted, and the receive buffer register can hold a character while the next character is being received.

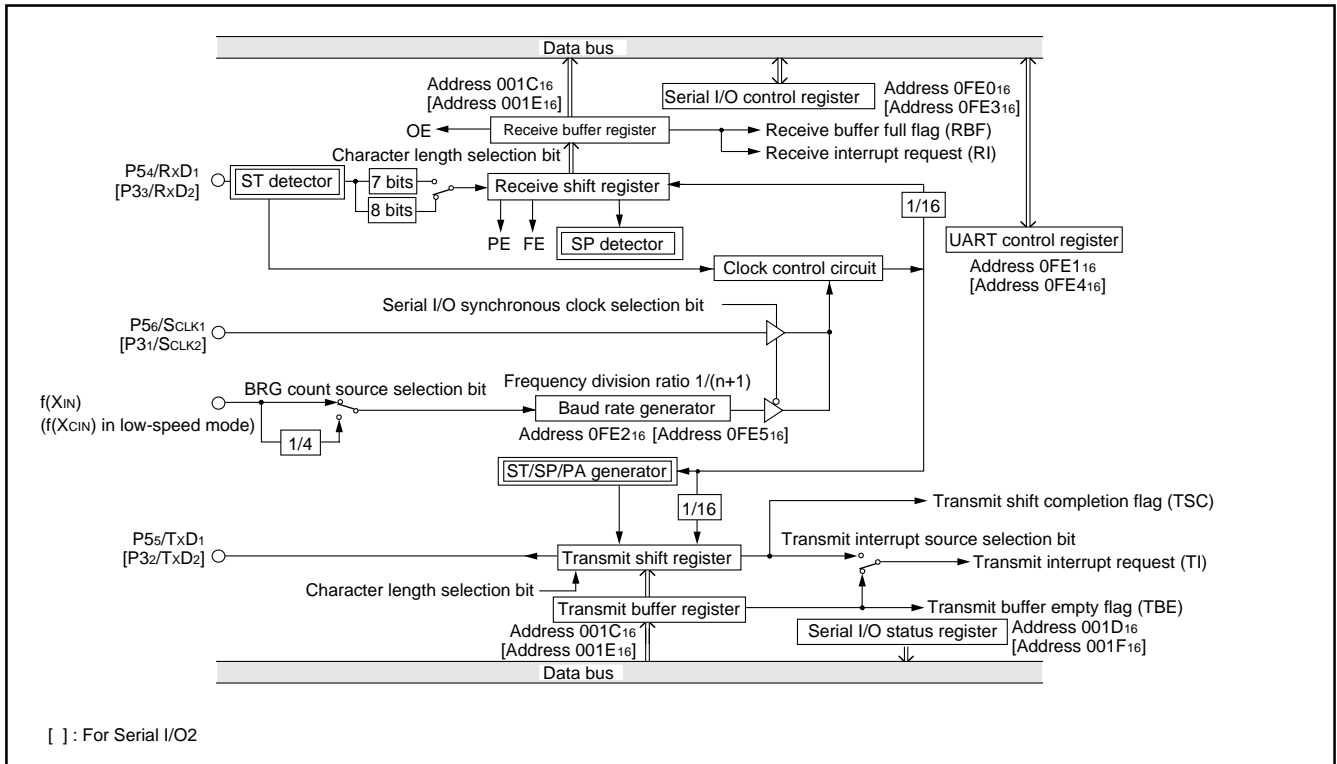

Fig. 27 Block diagram of UART serial I/O

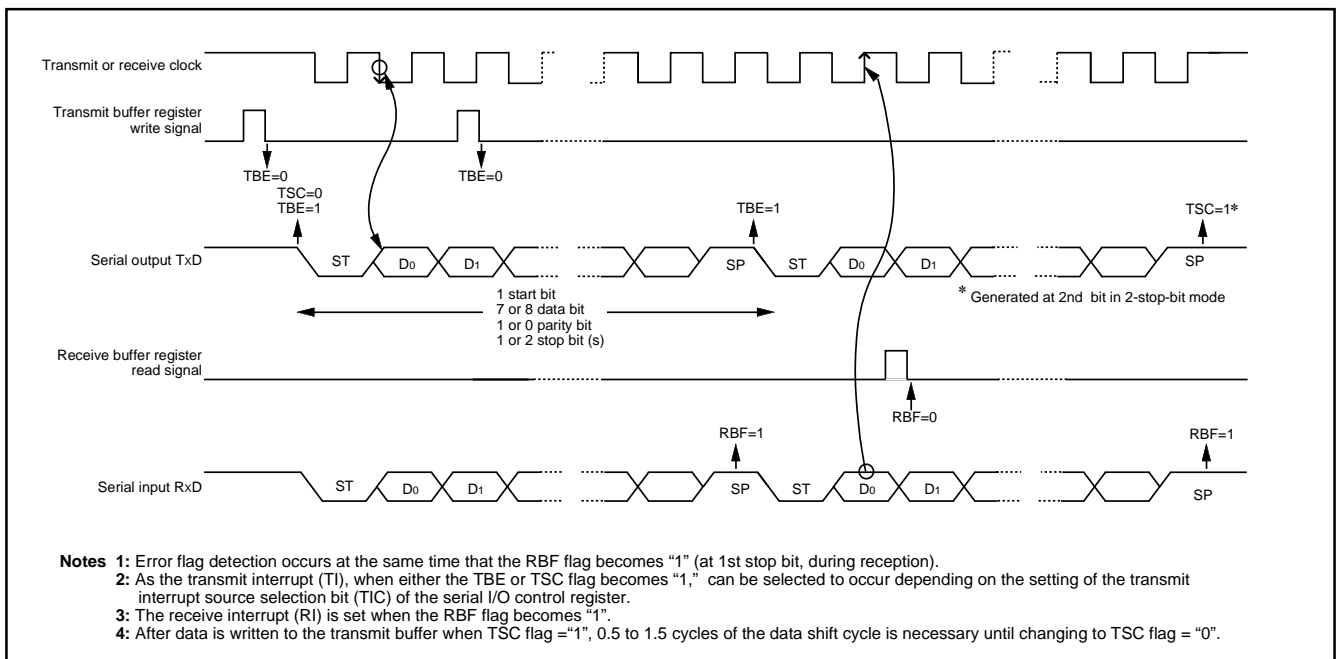

Fig. 28 Operation of UART serial I/O function

[Transmit Buffer Register/Receive Buffer Register (TB/RB)]

The transmit buffer register and the receive buffer register are located at the same address. The transmit buffer is write-only and the receive buffer is read-only. If a character bit length is 7 bits, the MSB of data stored in the receive buffer is "0".

[Serial I/O Status Register (SIO1STS, SIO2STS)]

The read-only serial I/O status register consists of seven flags (bits 0 to 6) which indicate the operating status of the serial I/O function and various errors.

Three of the flags (bits 4 to 6) are valid only in UART mode.

The receive buffer full flag (bit 1) is set to "0" when the receive buffer register is read.

If there is an error, it is detected at the same time that data is transferred from the receive shift register to the receive buffer register, and the receive buffer full flag is set. A write to the serial I/O status register sets all the error flags OE, PE, FE, and SE (bit 3 to bit 6, respectively) to "0". Writing "0" to the serial I/O enable bit SIOE (bit 7 of the serial I/O control register) also sets all the status flags to "0", including the error flags.

All bits of the serial I/O status register are set to "0" at reset, but if the transmit enable bit (bit 4) of the serial I/O control register has been set to "1", the transmit shift completion flag (bit 2) and the transmit buffer empty flag (bit 0) become "1".

[Serial I/O Control Register (SIO1CON, SIO2CON)]

The serial I/O control register consists of eight control bits for the serial I/O function.

[UART Control Register (UART1CON, UART2CON)]

The UART control register consists of four control bits (bits 0 to 3) which are valid when asynchronous serial I/O is selected and set the data format of an data transfer and one bit (bit 4) which is always valid and sets the output structure of the P55/TxD1 [P32/TxD2] pin.

[Baud Rate Generator (BRG1, BRG2)]

The baud rate generator determines the baud rate for serial transfer. The baud rate generator divides the frequency of the count source by $1/(n + 1)$, where n is the value written to the baud rate generator.

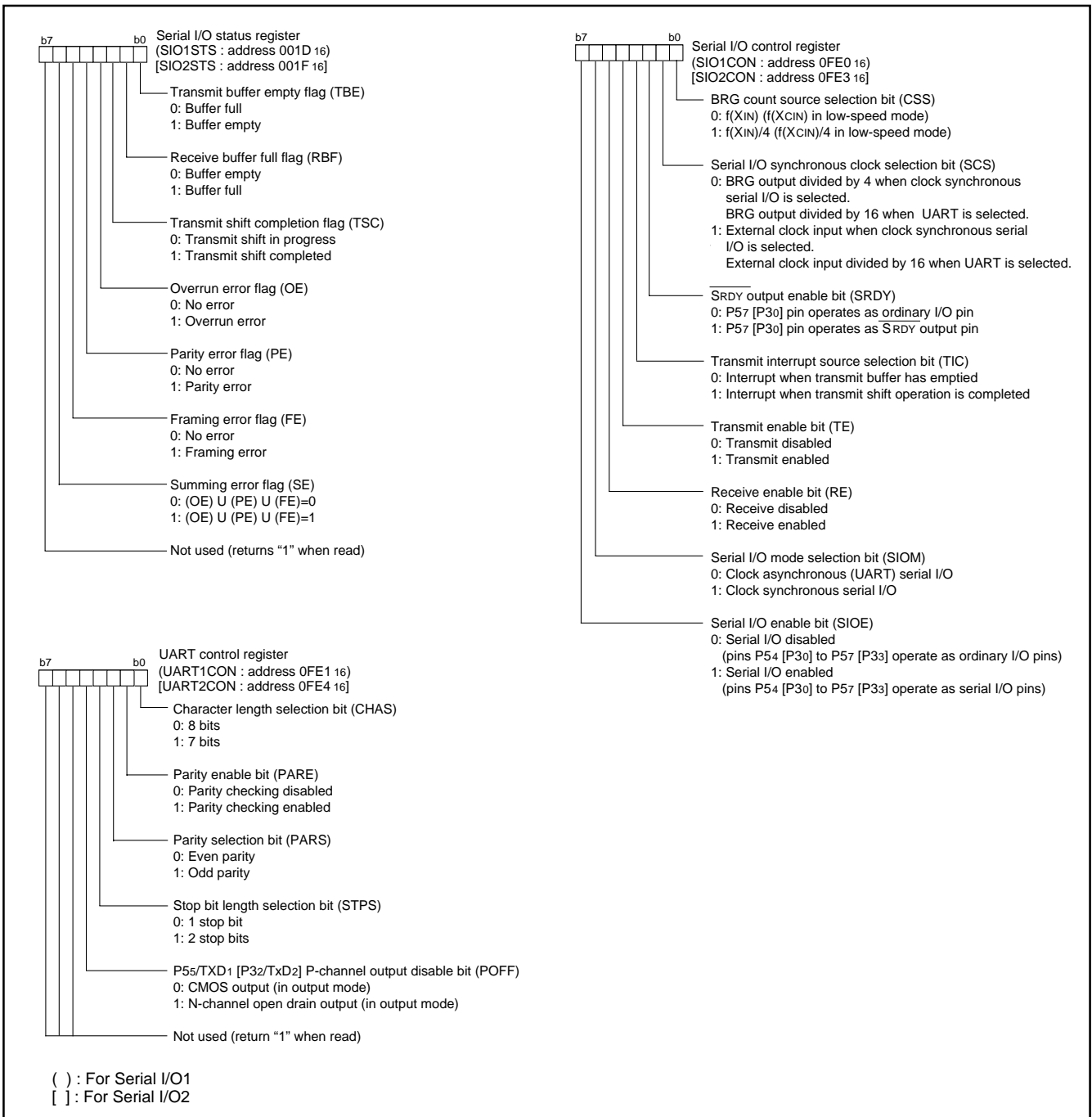

Fig. 29 Structure of serial I/O related registers

■Notes on serial I/O

When setting transmit enable bit to "1", the serial I/O transmit interrupt request bit is automatically set to "1". When not requiring the interrupt occurrence synchronous with the transmission enabled, take the following sequence.

- ①Set the serial I/O transmit interrupt enable bit to "0" (disabled).
- ②Set the transmit enable bit to "1".
- ③Set the serial I/O transmit interrupt request bit to "0" after 1 or more instructions have been executed.
- ④Set the serial I/O transmit interrupt enable bit to "1" (enabled).

A-D CONVERTER

The 38C2 group has a 10-bit A-D converter. The A-D converter performs successive approximation conversion.

[A-D Conversion Register (ADL, ADH)]

One of these registers is a high-order register, and the other is a low-order register. The high-order 8 bits of a conversion result is stored in the A-D conversion register (high-order) (address 001B16), and the low-order 2 bits of the same result are stored in bit 7 and bit 6 of the A-D conversion register (low-order) (address 001A16).

During A-D conversion, do not read these registers.

Also, the connection between the resistor ladder and reference voltage input pin (VREF) can be controlled by the VREF input switch bit (bit 0 of address 001A16). When "1" is written to this bit, the resistor ladder is always connected to VREF. When "0" is written to this bit, the resistor ladder is disconnected from VREF except during the A-D conversion.

[A-D Control Register (ADCON)]

This register controls A-D converter. Bits 2 to 0 are analog input pin selection bits. Bit 3 is an AD conversion completion bit and "0" during A-D conversion. This bit is set to "1" upon completion of A-D conversion. A-D conversion is started by setting "0" in this bit.

[Comparison Voltage Generator]

The comparison voltage generator divides the voltage between AVSS and VREF, and outputs the divided voltages.

[Channel Selector]

The channel selector selects one of the input ports P47/AN7-P40/AN0 and inputs it to the comparator.

[Comparator and Control Circuit]

The comparator and control circuit compares an analog input voltage with the comparison voltage and store the result in the A-D conversion register. When an A-D conversion is completed, the control circuit sets the AD conversion completion bit and the AD conversion interrupt request bit to "1."

Note that because the comparator consists of a capacitor coupling, set the A-D clock frequency to 250 kHz or more during an A-D conversion.

Also, when the STP instruction is executed during the A-D conversion, the A-D conversion is stopped immediately, the A-D conversion completion bit is set to "1", and the interrupt request is generated.

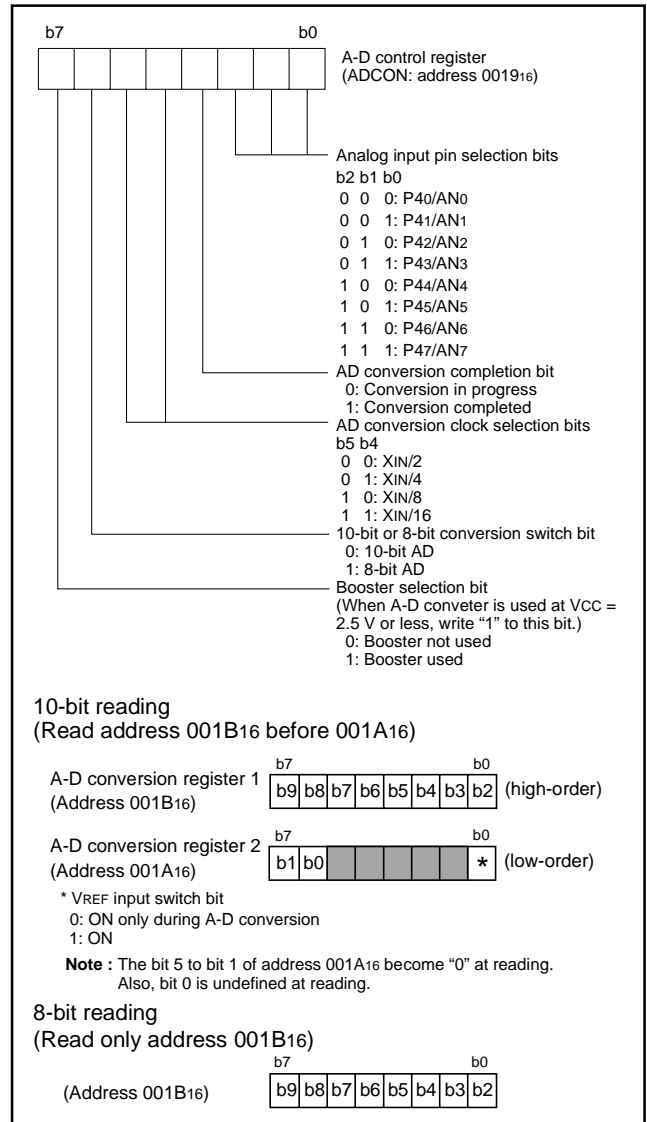

Fig. 30 Structure of A-D control register

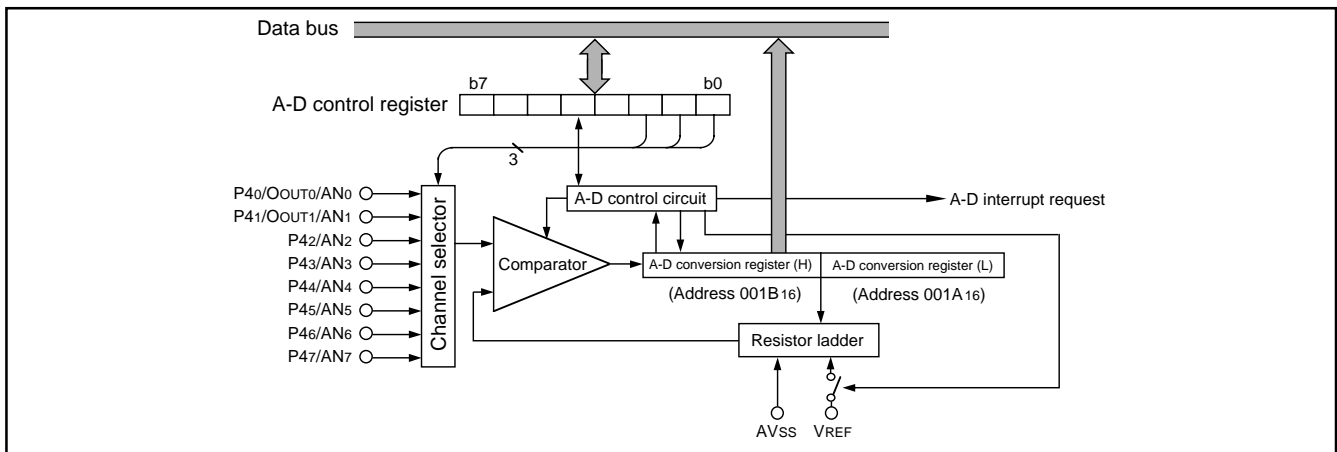

Fig. 31 Block diagram of A-D converter

LCD DRIVE CONTROL CIRCUIT

The 38C2 group has the built-in Liquid Crystal Display (LCD) drive control circuit consisting of the following.

- LCD display RAM
- Segment output disable register
- LCD mode register
- Selector
- Timing controller
- Common driver
- Segment driver
- Bias control circuit

A maximum of 24 segment output pins and 4 common output pins can be used.

Up to 96 pixels can be controlled for an LCD display. When the LCD enable bit is set to "1" after data is set in the LCD mode register, the

segment output disable register, and the LCD display RAM, the LCD drive control circuit starts reading the display data automatically, performs the bias control and the duty ratio control, and displays the data on the LCD panel.

Table 8 Maximum number of display pixels at each duty ratio

Duty ratio	Maximum number of display pixels
2	48 dots or 8 segment LCD 6 digits
3	72 dots or 8 segment LCD 9 digits
4	96 dots or 8 segment LCD 12 digits

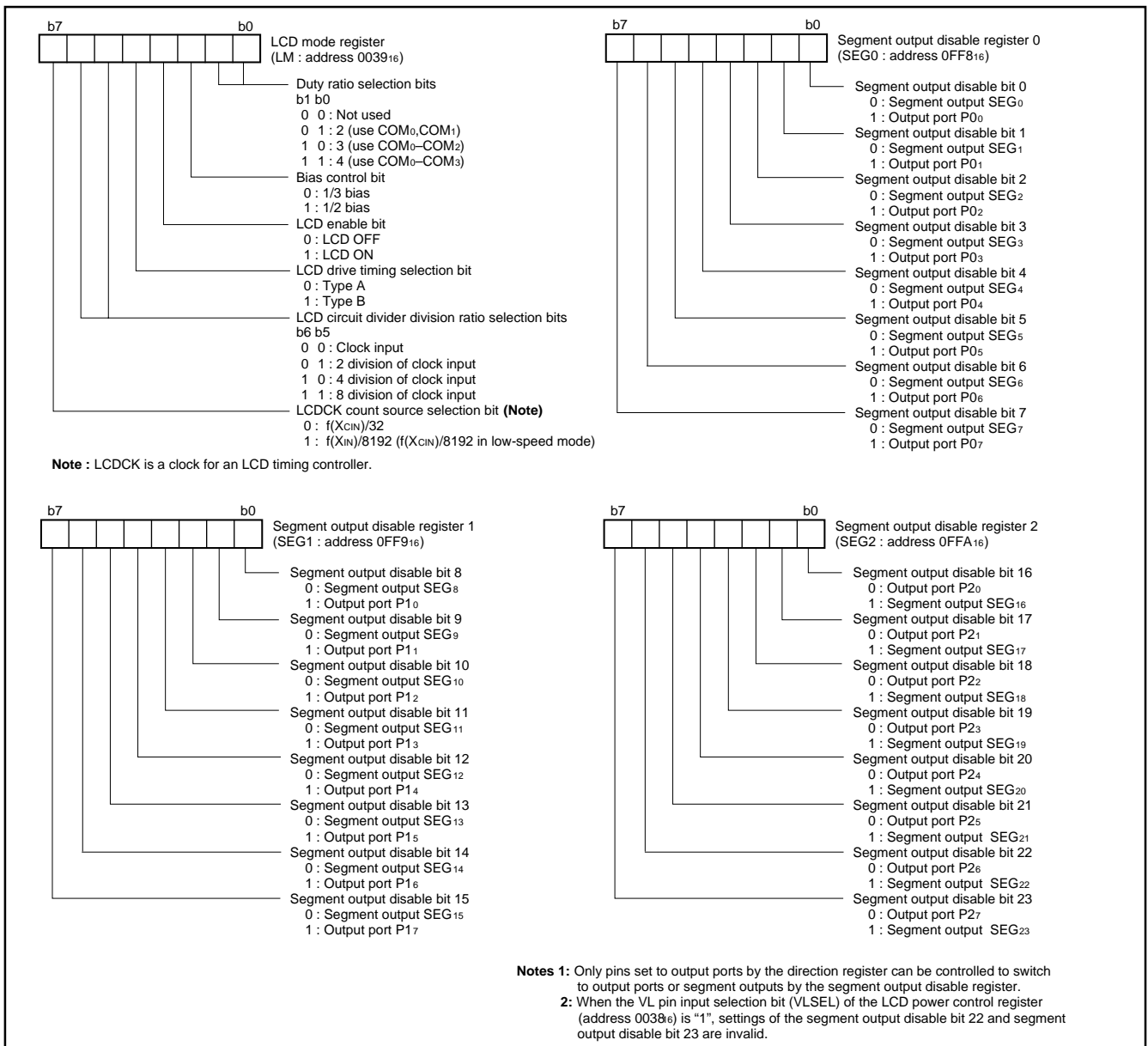

Fig. 32 Structure of LCD related registers

PRELIMINARY
 Notice: This is not a final specification.
 Some parametric limits are subject to change.

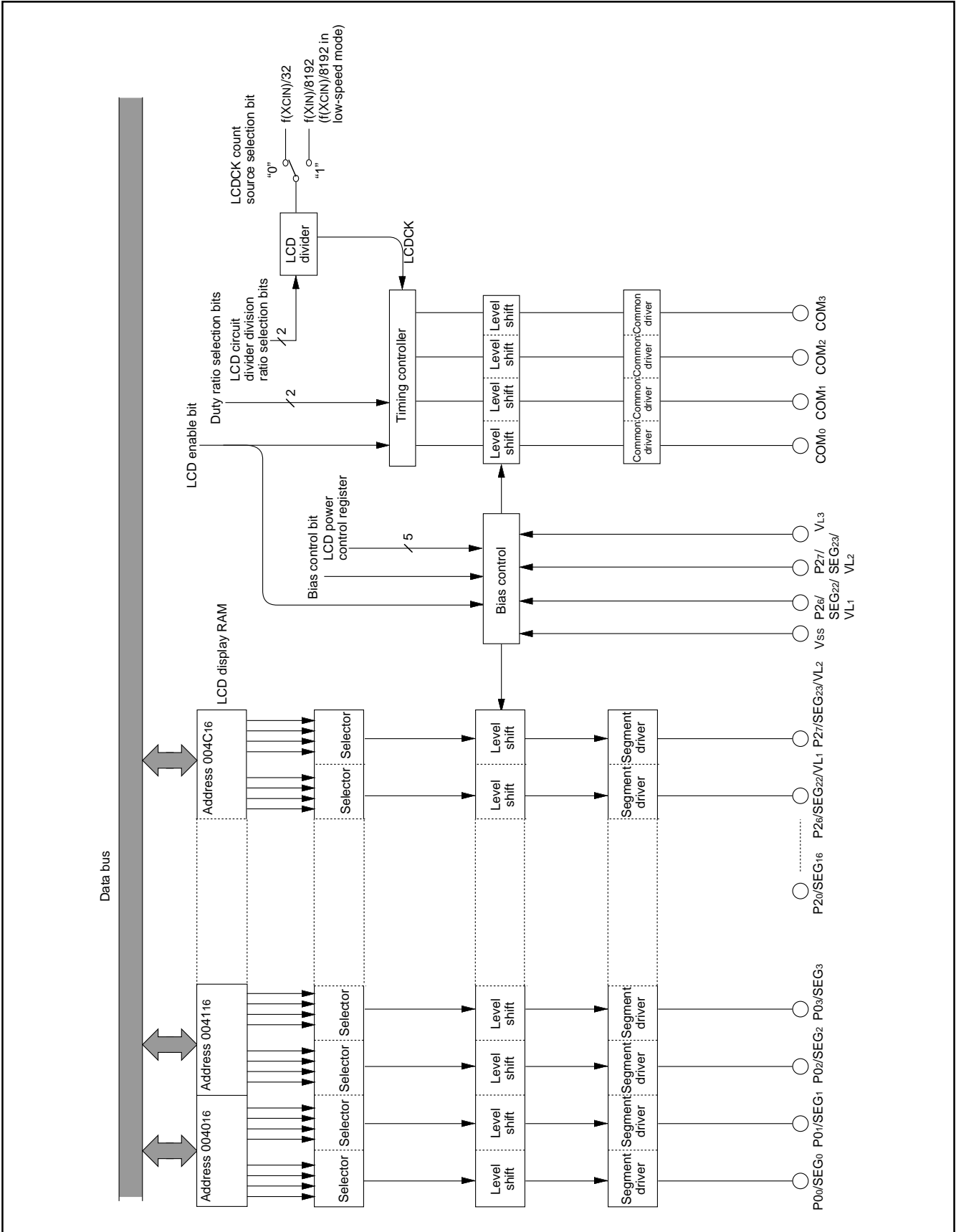

Fig. 33 Block diagram of LCD controller/driver

Bias Control and Applied Voltage to LCD Power Input Pins

When the voltage is applied from the LCD power input pins (VL1–VL3), set the VL pin input selection bit (bit 5 of the LCD power control register) and VL3 connection bit (bit 6 of LCD power control register) to “1”, apply the voltage value shown in Table 9 according to the bias value. In this case, SEG22 pin and SEG23 pin cannot be used. Select a bias value by the bias control bit (bit 2 of the LCD mode register).

Table 9 Bias control and applied voltage to VL1–VL3

Bias value	Voltage value
1/3 bias	VL3=VLCD VL2=2/3 VLCD VL1=1/3 VLCD
1/2 bias	VL3=VLCD VL2=VL1=1/2 VLCD

Note : VLCD is the maximum value of supplied voltage for the LCD panel.

Common Pin and Duty Ratio Control

The common pins (COM0–COM3) to be used are determined by duty ratio. Select duty ratio by the duty ratio selection bits (bits 0 and 1 of the LCD mode register). When reset is released, VCC voltage is output from the common pin.

Table 10 Duty ratio control and common pins used

Duty ratio	Duty ratio selection bits		Common pins used
	Bit 1	Bit 0	
2	0	1	COM0, COM1
3	1	0	COM0–COM2
4	1	1	COM0–COM3

Note: Unused common pin outputs the unselected waveform.

Segment Signal Output Pin

The segment signal output pins (SEG0–SEG23) are shared with ports P0–P2. When these pins are used as the segment signal output pins, set the direction registers of the corresponding pins to “1”, and set the segment output disable register to “0”.

Also, these pins are set to the input port after reset, the VCC voltage is output by the pull-up resistor.

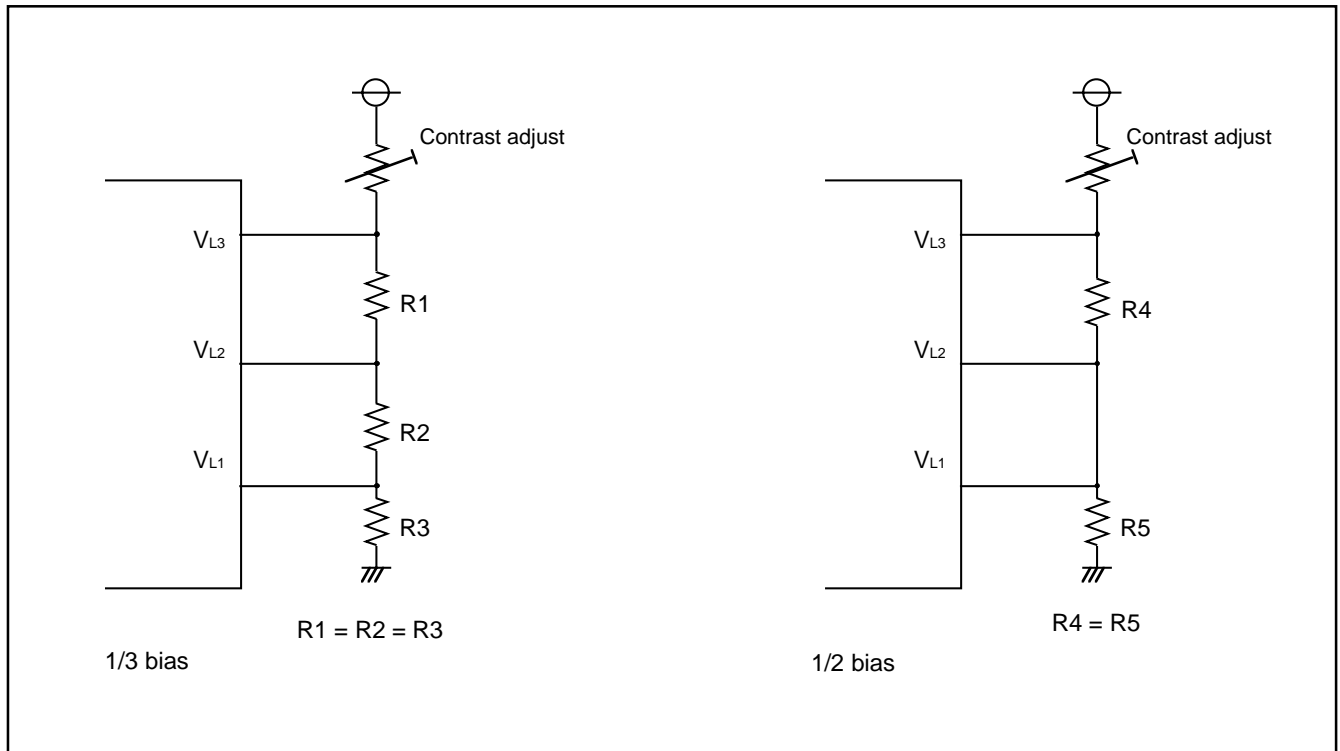

Fig. 34 Example of circuit at each bias (at external power input)

LCD Power Circuit

The LCD power circuit has the dividing resistor for LCD power which can be connected/disconnected with the LCD power control register.

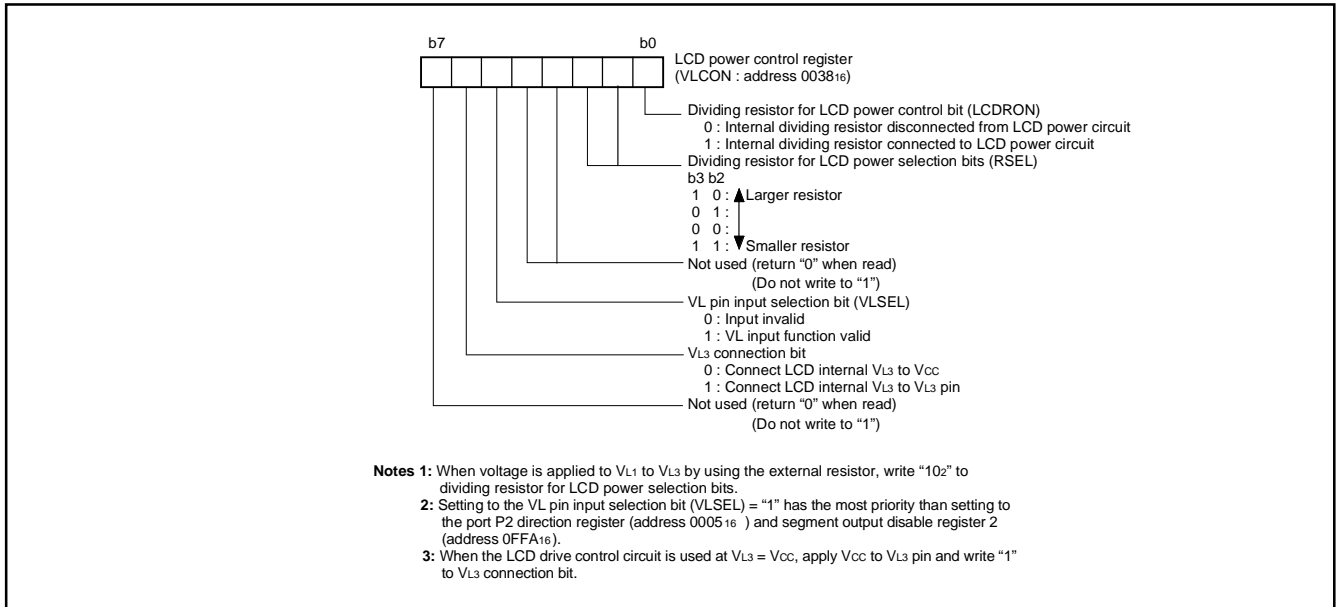

Fig. 35 Structure of LCD power control register

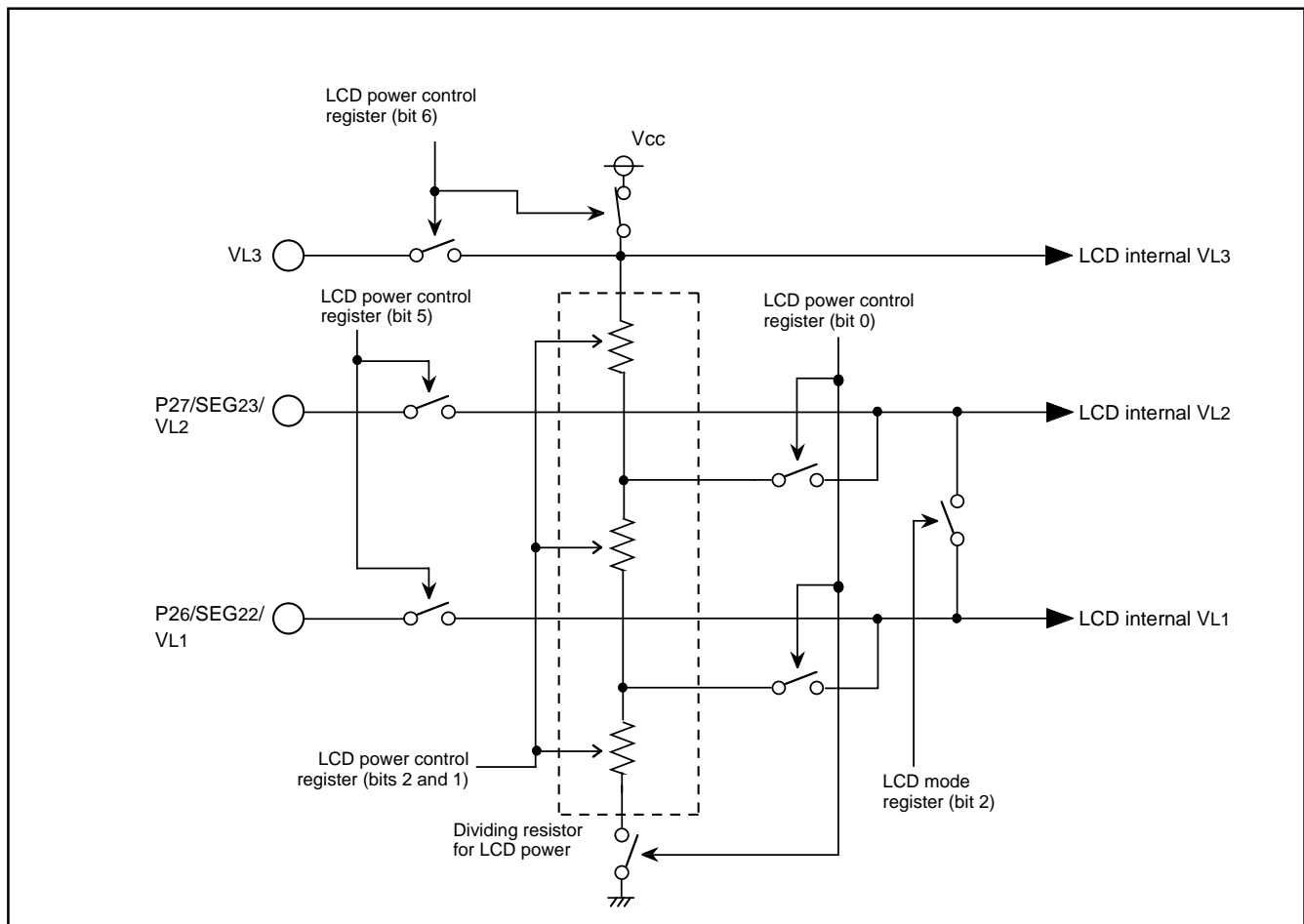

Fig. 36 VL block diagram

LCD Display RAM

The 12-byte area of address 0040₁₆ to 004B₁₆ is the designated RAM for the LCD display. When "1" is written to these addresses, the corresponding segments of the LCD display panel are turned on.

LCD Drive Timing

For the LCD drive timing, type A or type B can be selected. The LCD drive timing is selected by the timing selection bit (bit 4 of LCD mode register). Type A is selected by setting the LCD drive timing selection bit to "0", type B is selected by setting the bit to "1". Type A is selected after reset.

The LCDCK timing frequency (LCD drive timing) is generated internally and the frame frequency can be determined with the following equation;

$$f(\text{LCDCK}) = \frac{\text{(frequency of count source for LCDCK)}}{\text{(divider division ratio for LCD)}}$$

$$\text{Frame frequency} = \frac{f(\text{LCDCK})}{\text{duty ratio}}$$

■ Note

- (1) When the STP instruction is executed, the following bits are set to "0";
 - LCD enable bit (bit 3 of LCD mode register)
 - Bits other than bit 6 of the LCD power control register.
- (2) When the voltage is applied to VL1 to VL3 by using the external resistor, write "102" to dividing resistor for LCD power selection bits (RSEL) of the LCD power control register (address 0038₁₆).
- (3) When the LCD drive control circuit is used at VL3 = VCC, apply VCC to VL3 pin and write "1" to VL3 connection bit of the LCD power control register (address 0038₁₆).

Bit Address	7	6	5	4	3	2	1	0
0040 ₁₆	SEG1			SEG0				
0041 ₁₆	SEG3			SEG2				
0042 ₁₆	SEG5			SEG4				
0043 ₁₆	SEG7			SEG6				
0044 ₁₆	SEG9			SEG8				
0045 ₁₆	SEG11			SEG10				
0046 ₁₆	SEG13			SEG12				
0047 ₁₆	SEG15			SEG14				
0048 ₁₆	SEG17			SEG16				
0049 ₁₆	SEG19			SEG18				
004A ₁₆	SEG21			SEG20				
004B ₁₆	SEG23			SEG22				
	COM3	COM2	COM1	COM0	COM3	COM2	COM1	COM0

Fig. 37 LCD display RAM map

PRELIMINARY
 Notice: This is not a final specification.
 Some parametric limits are subject to change.

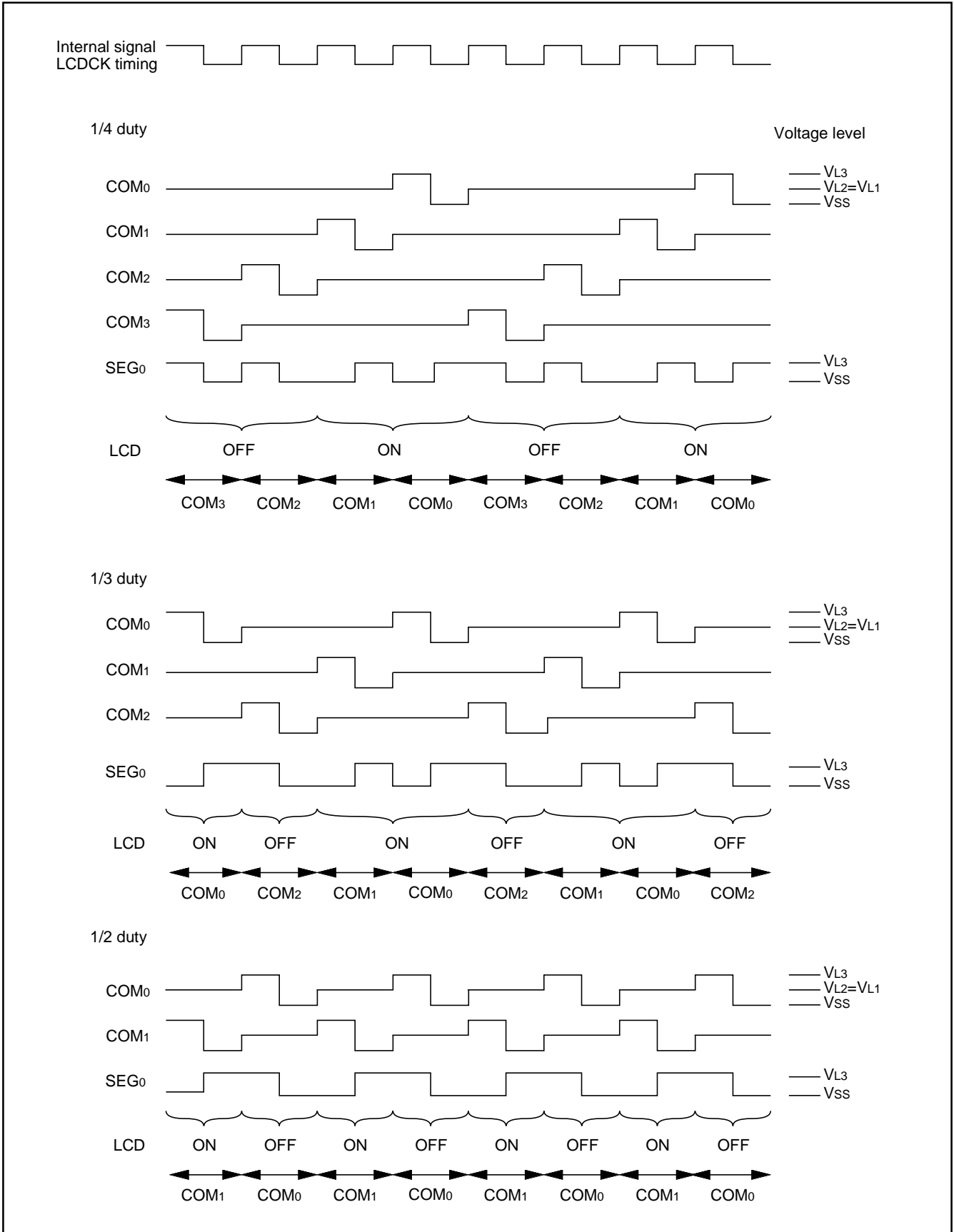

Fig. 38 LCD drive waveform (1/2 bias, type A)

PRELIMINARY
 Notice: This is not a final specification.
 Some parametric limits are subject to change.

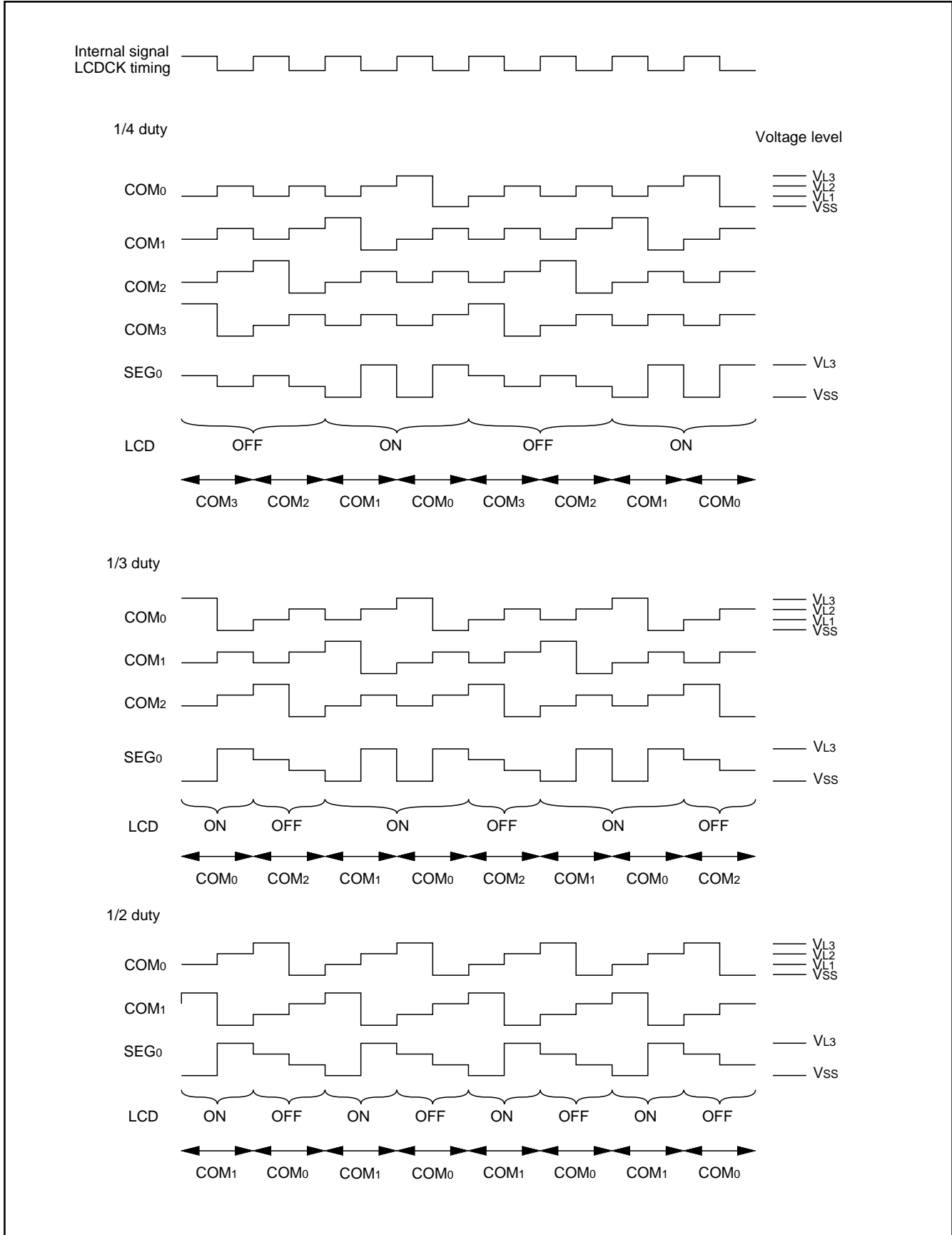

Fig. 39 LCD drive waveform (1/3 bias, type A)

PRELIMINARY
 Notice: This is not a final specification.
 Some parametric limits are subject to change.

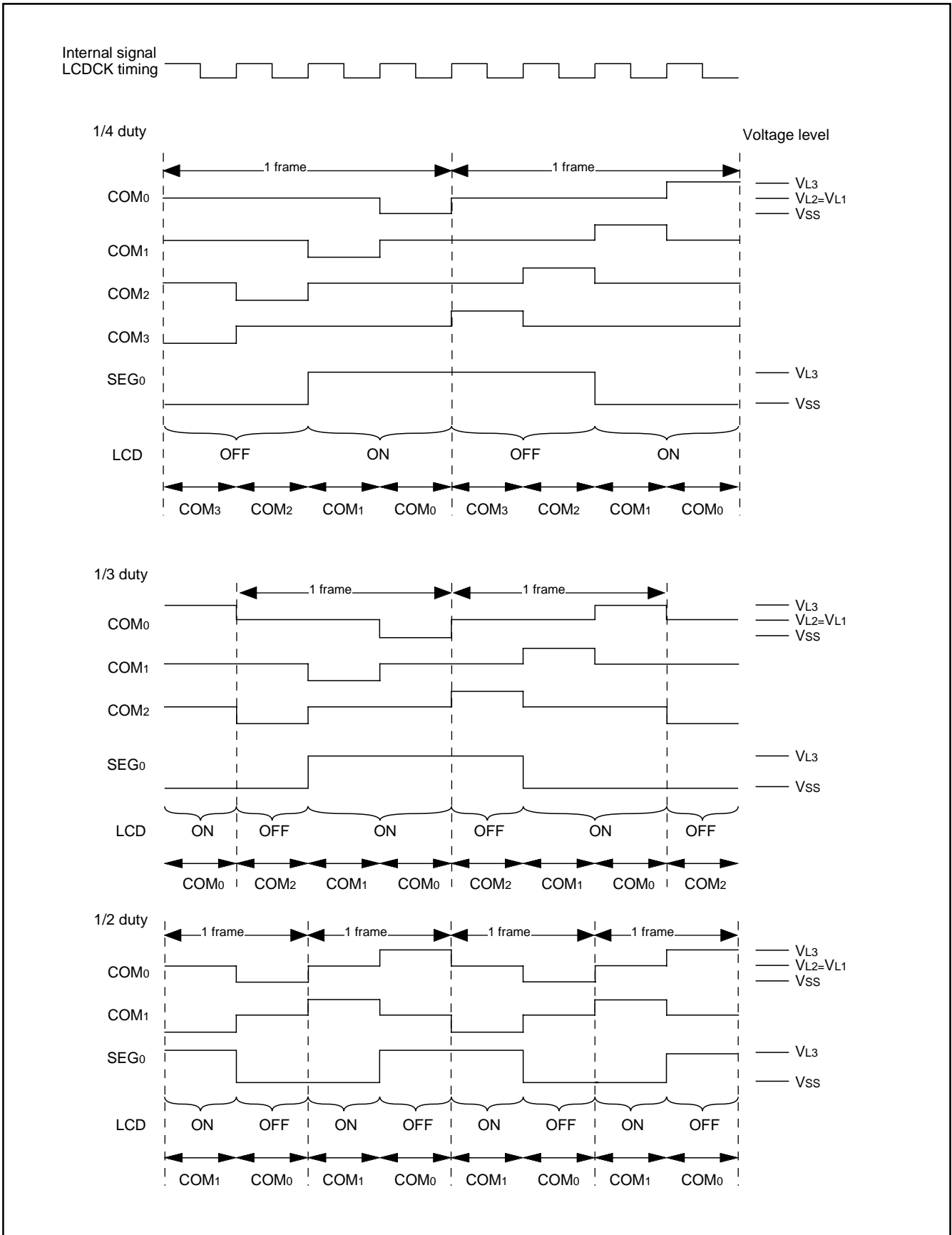

Fig. 40 LCD drive waveform (1/2 bias, type B)

PRELIMINARY
 Notice: This is not a final specification.
 Some parametric limits are subject to change.

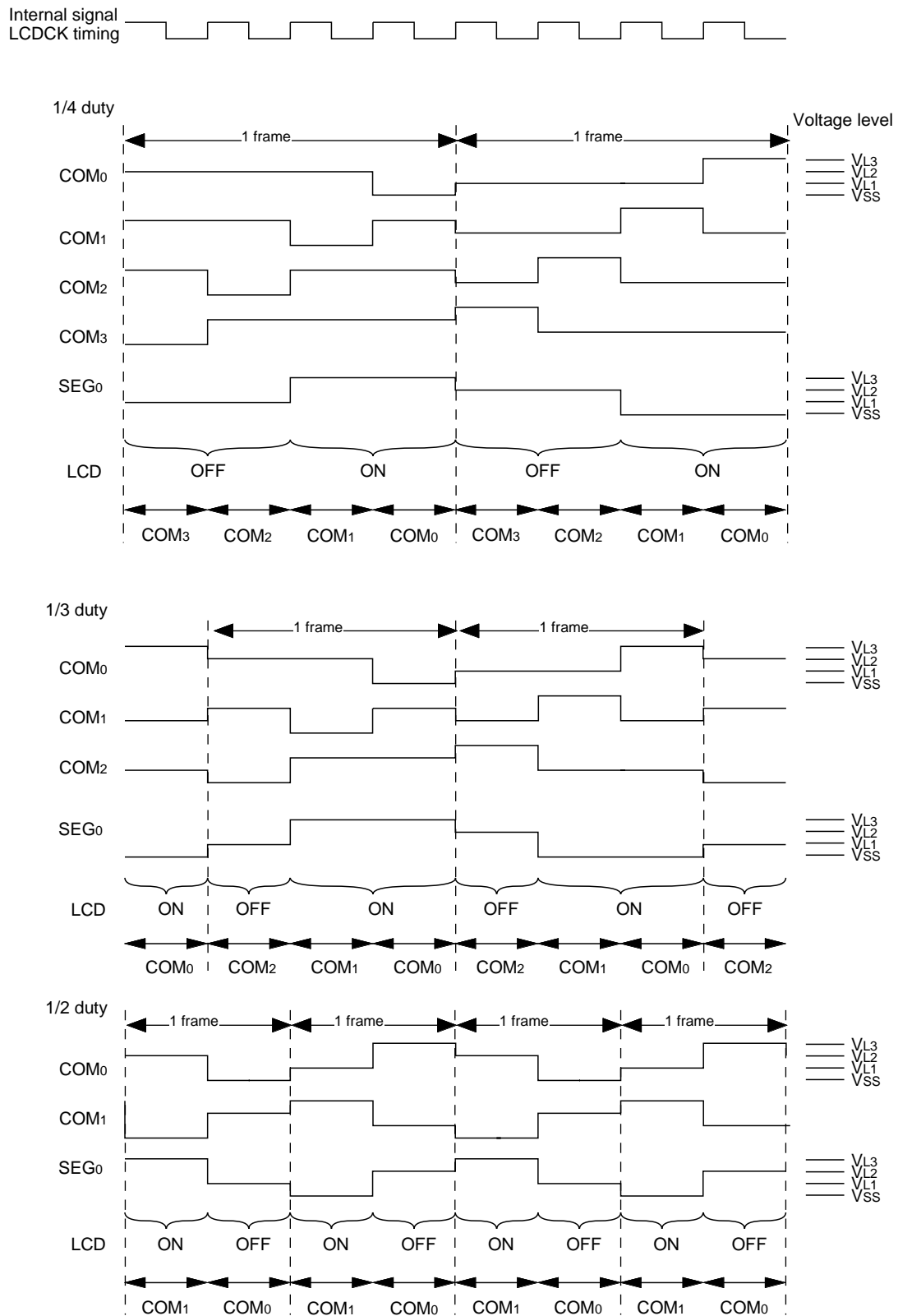

Fig. 41 LCD drive waveform (1/3 bias, type B)

WATCHDOG TIMER

The watchdog timer gives a mean of returning to the reset status when a program cannot run on a normal loop (for example, because of a software run-away). The watchdog timer consists of an 8-bit counter.

Initial Value of Watchdog Timer

At reset or writing to the watchdog timer control register, each watchdog timer is set to "FF16." Instructions such as STA, LDM and CLB to generate the write signals can be used.

The written data in bits 0 to 5 are not valid, and the above values are set.

Standard Operation of Watchdog Timer

The watchdog timer is in the stop state at reset and the watchdog timer starts to count down by writing an optional value in the watchdog timer control register. An internal reset occurs at an underflow of the watchdog timer. Then, reset is released after the reset release time is elapsed, the program starts from the reset vector address. Normally, writing to the watchdog timer control register before an underflow of the watchdog timer is programmed. If writing to the watchdog control register is not executed, the watchdog timer does not operate.

When reading the watchdog timer control register is executed, the contents of the high-order 6-bit counter and the STP instruction disable bit (bit 6), and the count source selection bit (bit 7) are read out. When the STP instruction disable bit is "0", the STP instruction is valid. The STP instruction is disabled by writing to "1" to this bit. In this time, when the STP instruction is executed, it is handled as the undefined instruction, the internal reset occurs. This bit cannot be set to "0" by program. This bit is "0" after reset.

The time until the underflow of the watchdog timer control register after writing to the watchdog timer control register is executed is as follows (when the bit 7 of the watchdog timer control register is "0") ;

- at frequency/2/4/8 mode ($f(XIN) = 8\text{ MHz}$): 32.768 ms
- at low-speed mode ($f(XCIN) = 32\text{ KHz}$): 8.19s

■ Note

The watchdog timer continues to count even during the wait time set by timer 1 and timer 2 to release the stop state and in the wait mode. Accordingly, do not underflow the watchdog timer in this time.

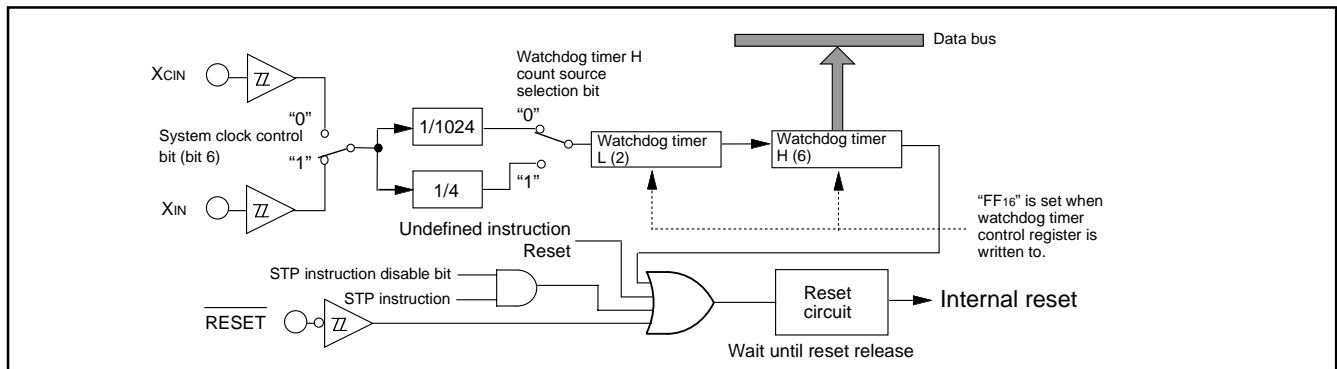

Fig. 42 Block diagram of Watchdog timer

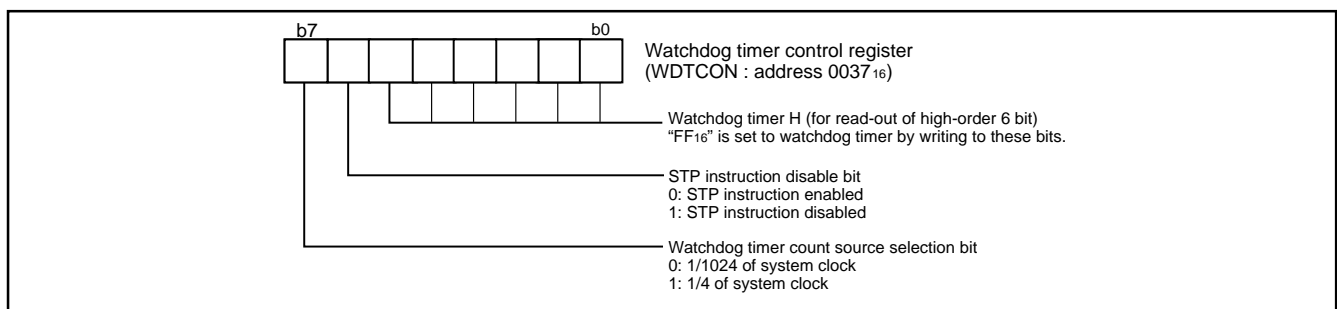

Fig. 43 Structure of Watchdog timer control register

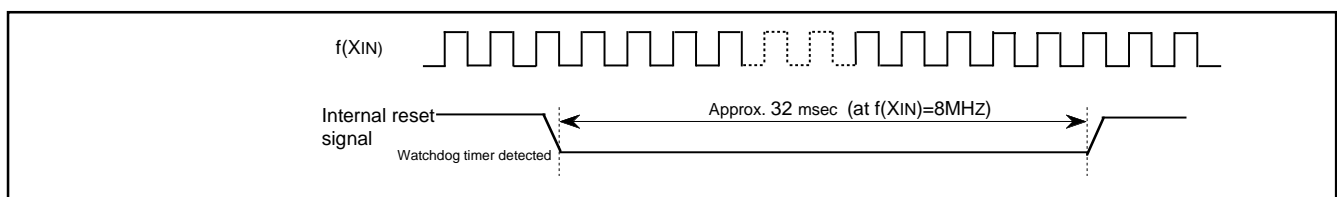

Fig. 44 Timing diagram of reset output

CLOCK OUTPUT FUNCTION

A system clock ϕ can be output from I/O port P36. The triple function of I/O port, timer 2 output function and system clock ϕ output function is performed by the clock output control register (address 0018₁₆) and the timer 2 output selection bit of the timer 12 mode register (address 0025₁₆).

In order to output a system clock ϕ from I/O port P36, set the timer 2 output selection bit and bit 0 of the clock output control register to "1". When the clock output function is selected, a clock is output while the direction register of port P36 is set to the output mode.

P36 is switched to the port output or the output (timer 2 output and the clock output) except port at the cycle after the timer 2 output control bit is switched.

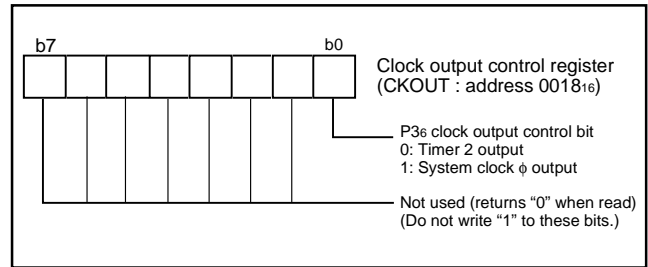

Fig. 45 Structure of clock output control register

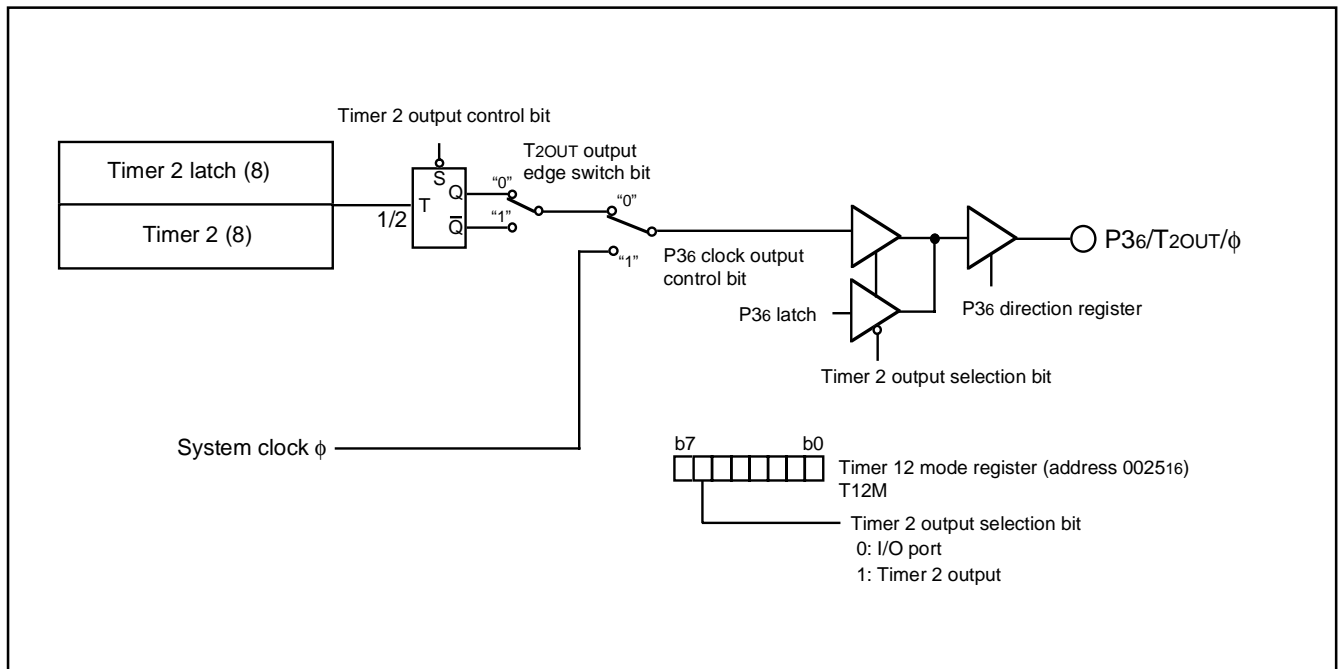

Fig. 46 Block diagram of Clock output function

RESET CIRCUIT

To reset the microcomputer, $\overline{\text{RESET}}$ pin should be held at an "L" level for 2 μs or more. Then the $\overline{\text{RESET}}$ pin is returned to an "H" level (the power source voltage should be between V_{CC} (min.) and 5.5 V, and the quartz-crystal oscillator should be stable), reset is released. After the reset is completed, the program starts from the address contained in address FFFD₁₆ (high-order byte) and address FFFC₁₆ (low-order byte). Make sure that the reset input voltage meets V_{IL} spec. when a power source voltage passes V_{CC} (min.).

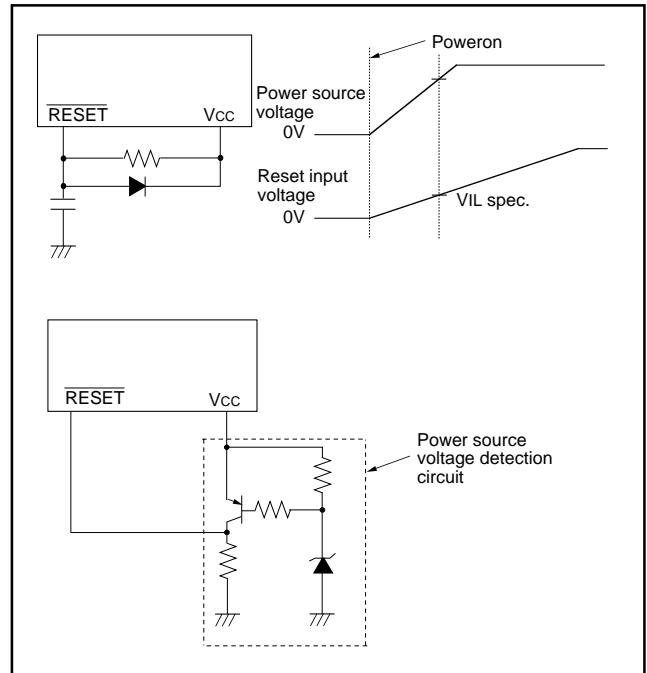

Fig. 47 Reset circuit example

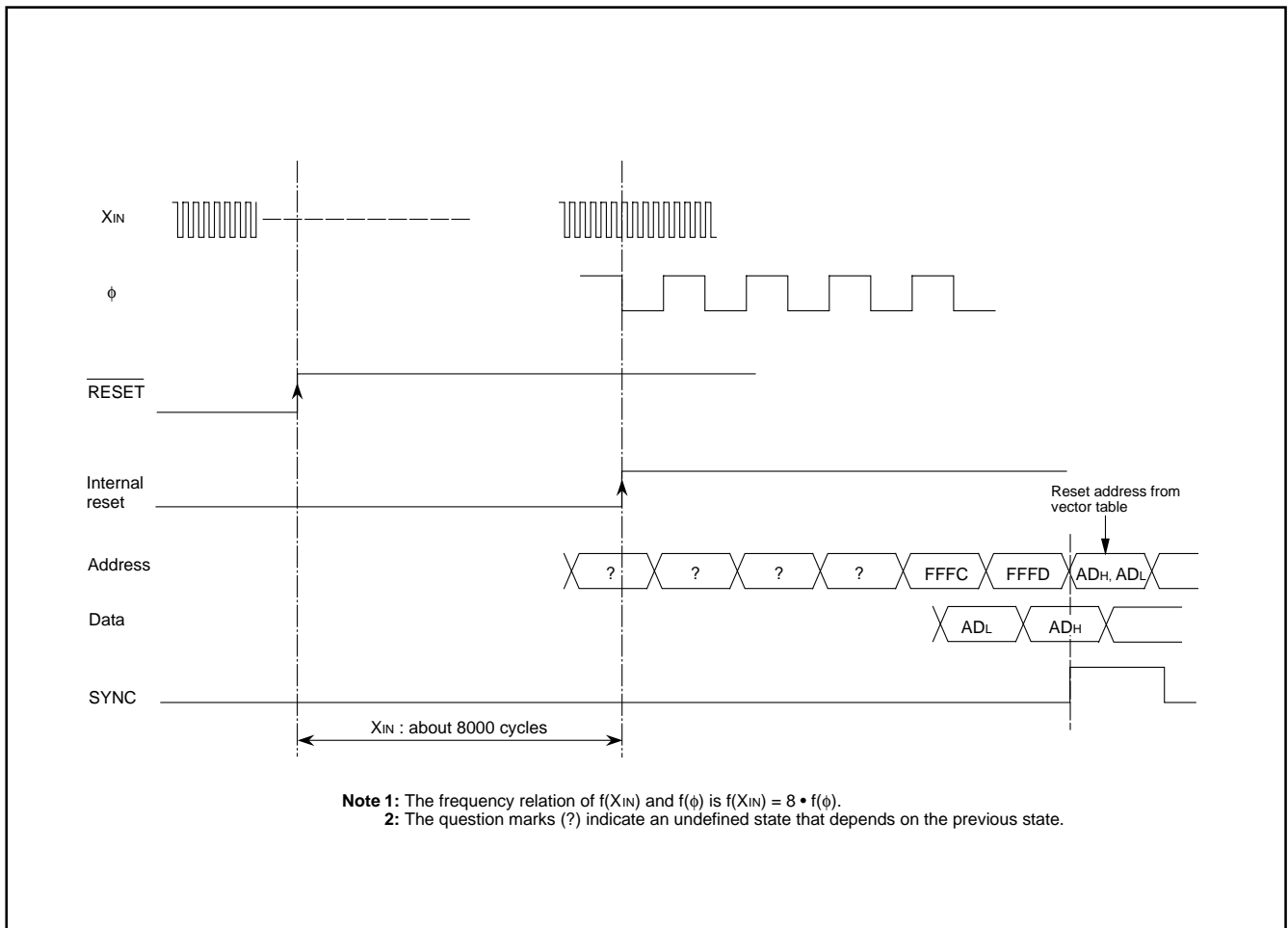

Fig. 48 Reset sequence

	Address	Register contents		Address	Register contents
(1) Port P0	0000 ₁₆	00 ₁₆	(35) Watchdog timer control register	0037 ₁₆	00111111
(2) Port P0 direction register	0001 ₁₆	00 ₁₆	(36) LCD power control register	0038 ₁₆	00 ₁₆
(3) Port P1	0002 ₁₆	00 ₁₆	(37) LCD mode register	0039 ₁₆	00 ₁₆
(4) Port P1 direction register	0003 ₁₆	00 ₁₆	(38) Interrupt edge selection register	003A ₁₆	00 ₁₆
(5) Port P2	0004 ₁₆	00 ₁₆	(39) CPU mode register	003B ₁₆	01001000
(6) Port P2 direction register	0005 ₁₆	00 ₁₆	(40) Interrupt request register 1	003C ₁₆	00 ₁₆
(7) Port P3	0006 ₁₆	00 ₁₆	(41) Interrupt request register 2	003D ₁₆	00 ₁₆
(8) Port P3 direction register	0007 ₁₆	00 ₁₆	(42) Interrupt control register 1	003E ₁₆	00 ₁₆
(9) Port P4	0008 ₁₆	00 ₁₆	(43) Interrupt control register 2	003F ₁₆	00 ₁₆
(10) Port P4 direction register	0009 ₁₆	00 ₁₆	(44) Serial I/O1 control register	0FE0 ₁₆	00 ₁₆
(11) Port P5	000A ₁₆	00 ₁₆	(45) UART1 control register	0FE1 ₁₆	11100000
(12) Port P5 direction register	000B ₁₆	00 ₁₆	(46) Serial I/O2 control register	0FE3 ₁₆	00 ₁₆
(13) Port P6	000C ₁₆	00 ₁₆	(47) UART2 control register	0FE4 ₁₆	11100000
(14) Port P6 direction register	000D ₁₆	00 ₁₆	(48) Oscillation output control register	0FF0 ₁₆	00 ₁₆
(15) Clock output control register	0018 ₁₆	00 ₁₆	(49) PULL register	0FF1 ₁₆	00 ₁₆
(16) A-D control register	0019 ₁₆	08 ₁₆	(50) Key input control register	0FF2 ₁₆	00 ₁₆
(17) Serial I/O1 status register	001D ₁₆	10000000	(51) Timer 1234 mode register	0FF3 ₁₆	00 ₁₆
(18) Serial I/O2 status register	001F ₁₆	10000000	(52) Timer X control register	0FF4 ₁₆	00 ₁₆
(19) Timer 1	0020 ₁₆	FF ₁₆	(53) Timer 12 frequency division selection register	0FF5 ₁₆	00 ₁₆
(20) Timer 2	0021 ₁₆	01 ₁₆	(54) Timer 34 frequency division selection register	0FF6 ₁₆	00 ₁₆
(21) Timer 3	0022 ₁₆	FF ₁₆	(55) Timer XY frequency division selection register	0FF7 ₁₆	00 ₁₆
(22) Timer 4	0023 ₁₆	FF ₁₆	(56) Segment output disable register 0	0FF8 ₁₆	FF ₁₆
(23) PWM01 register	0024 ₁₆	00 ₁₆	(57) Segment output disable register 1	0FF9 ₁₆	FF ₁₆
(24) Timer 12 mode register	0025 ₁₆	00 ₁₆	(58) Segment output disable register 2	0FFA ₁₆	FF ₁₆
(25) Timer 34 mode register	0026 ₁₆	00 ₁₆	(59) Timer Y mode register 2	0FFB ₁₆	00 ₁₆
(26) Compare register (low-order)	0028 ₁₆	00 ₁₆	(60) Flash memory control register	0FFE ₁₆	XXXX0001
(27) Compare register (high-order)	0029 ₁₆	00 ₁₆	(61) Processor status register	(PS)	XXXXX1XX
(28) Timer X (low-order)	002A ₁₆	FF ₁₆	(62) Program counter	(PC _H)	FFFD ₁₆ contents
(29) Timer X (high-order)	002B ₁₆	FF ₁₆		(PC _L)	FFFC ₁₆ contents
(30) Timer X (extension)	002C ₁₆	00 ₁₆			
(31) Timer Y (low-order)	002D ₁₆	FF ₁₆			
(32) Timer Y (high-order)	002E ₁₆	FF ₁₆			
(33) Timer X mode register	002F ₁₆	00 ₁₆			
(34) Timer Y mode register	0030 ₁₆	00 ₁₆			

X: Not fixed
 Since the initial values for other than above mentioned registers and RAM contents are indefinite at reset, they must be set.

Fig. 49 Internal status at reset

CLOCK GENERATING CIRCUIT

The 38C2 group has two built-in oscillation circuits; main clock XIN-XOUT and sub-clock XCIN-XCOUT. An oscillation circuit can be formed by connecting a resonator between XIN and XOUT (XCIN and XCOUT). Use the circuit constants in accordance with the resonator manufacturer's recommended values. No external resistor is needed between XIN and XOUT since a feedback resistor exists on-chip. However, an external feedback resistor is needed between XCIN and XCOUT.

To supply a clock signal externally, input it to the XIN pin and make the XOUT pin open. The sub clock XCIN-XCOUT oscillation circuit cannot directly input clocks that are externally generated. Accordingly, be sure to cause an external resonator to oscillate.

Immediately after poweron, only the XIN oscillation circuit starts oscillating, and XCIN and XCOUT pins function as I/O ports.

Frequency Control

(1) Frequency/8 Mode

The system clock ϕ is the frequency of XIN divided by 8. After reset is released, this mode is selected.

(2) Frequency/4 Mode

The system clock ϕ is the frequency of XIN divided by 4.

(3) Frequency/2 Mode

The system clock ϕ is the frequency of XIN divided by 2.

(4) Low-speed Mode

The system clock ϕ is the frequency of XCIN divided by 2. In the low-speed mode, the low-power dissipation operation can be performed when the main clock XIN is stopped by setting the bit 7 of the CPU mode register to "0". In this case, when main clock XIN oscillation is restarted, generate the wait time until the oscillation is stable by program after the bit 7 of the CPU mode register is set to "1".

Notes on Clock Generating Circuit

If you switch the mode between frequency/2/4, or 8 and low-speed, stabilize both XIN and XCIN oscillations. The sufficient time is required for the sub clock to stabilize, especially immediately after power on and at returning from stop mode. When switching the mode, set the frequency in the condition that $f(XIN) > 3 \cdot f(XCIN)$.

Oscillation Control

(1) Stop Mode

If the STP instruction is executed, the system clock ϕ stops at an "H" level, and main clock and sub-clock oscillators stop.

In this time, values set previously to timer 1 latch and timer 2 latch are loaded automatically to timer 1 and timer 2. Set the values to generate the wait time required for oscillation stabilization to timer 1 latch and timer 2 latch (low-order 8 bits of timer 1 and high-order 8 bits of timer 2) before the STP instruction.

The frequency divider for timer 1 is used for the timer 1 count source, and the output of timer 1 is forcibly connected to timer 2. In this time, bits 0 to 5 of the timer 12 mode register are cleared to "0".

The values of the timer 12 frequency divider selection register are not changed.

Set the interrupt enable bits of the timer 1 and timer 2 to disabled ("0") before executing the STP instruction.

Oscillator restarts when reset occurs or an interrupt request is received, but the system clock ϕ is not supplied to the CPU until timer 2 underflows. This allows time for the clock circuit oscillation to stabilize.

(2) Wait Mode

If the WIT instruction is executed, only the system clock ϕ stops at an "H" state. The states of main clock and sub clock are the same as the state before executing the WIT instruction, and oscillation does not stop. Since supply of system clock ϕ is started immediately after the interrupt is received, the instruction can be executed immediately.

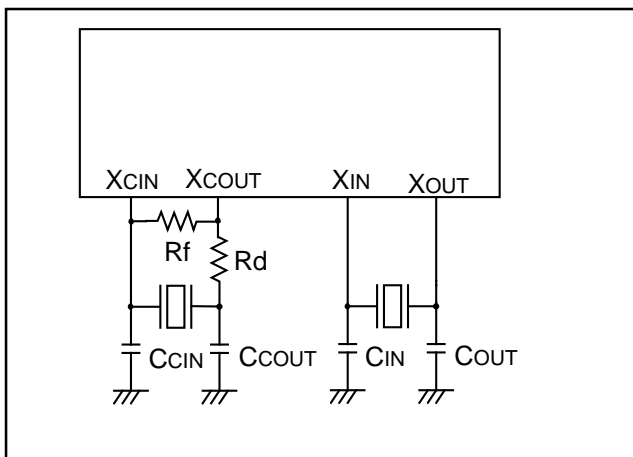

Fig. 50 Ceramic resonator circuit

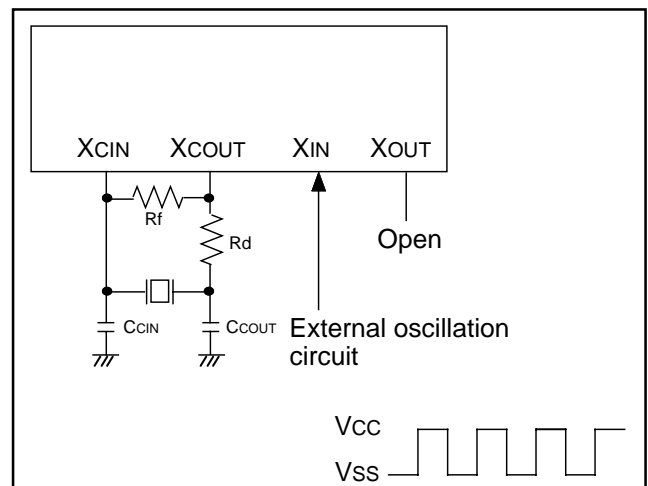

Fig. 51 External clock input circuit

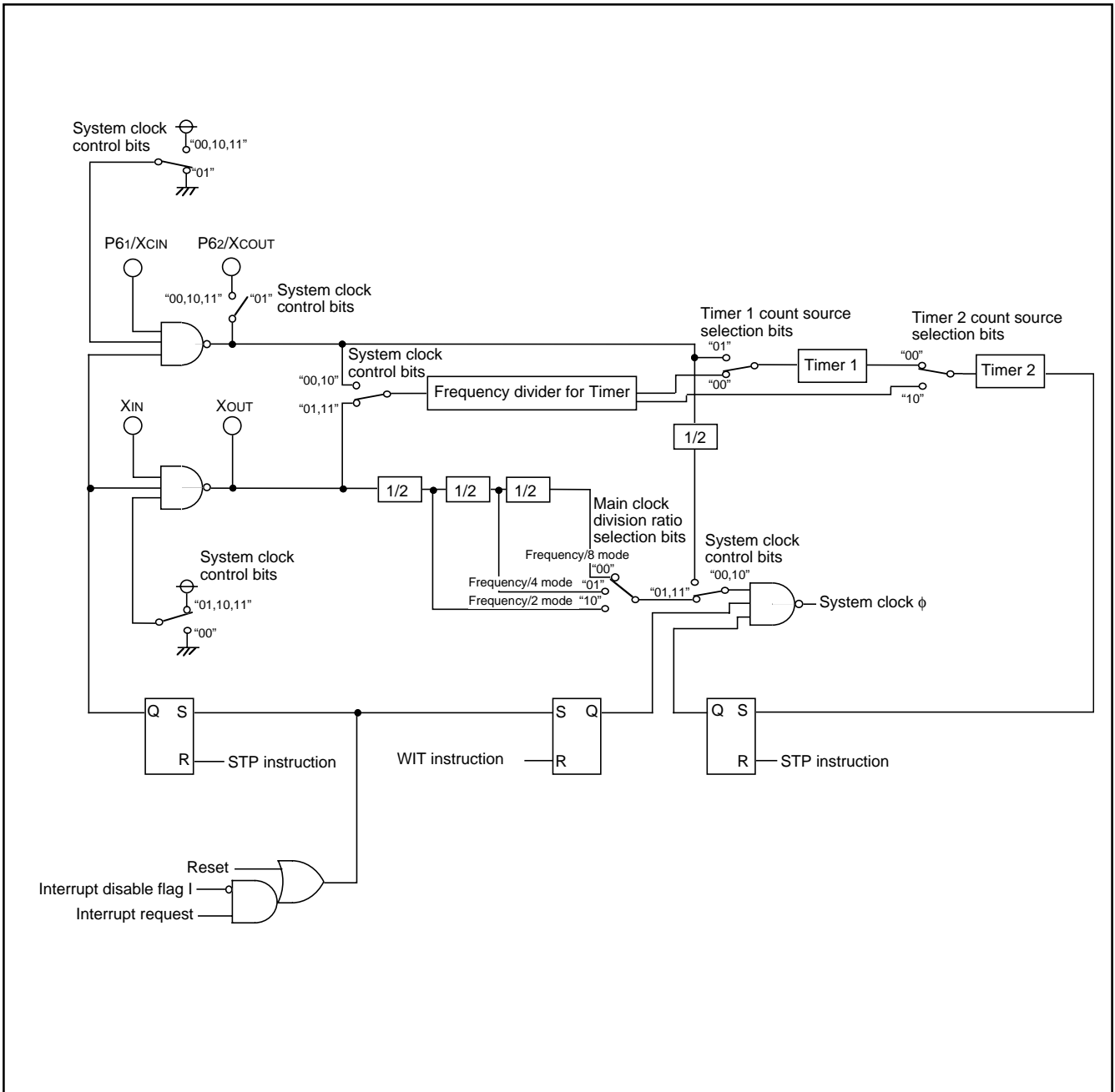
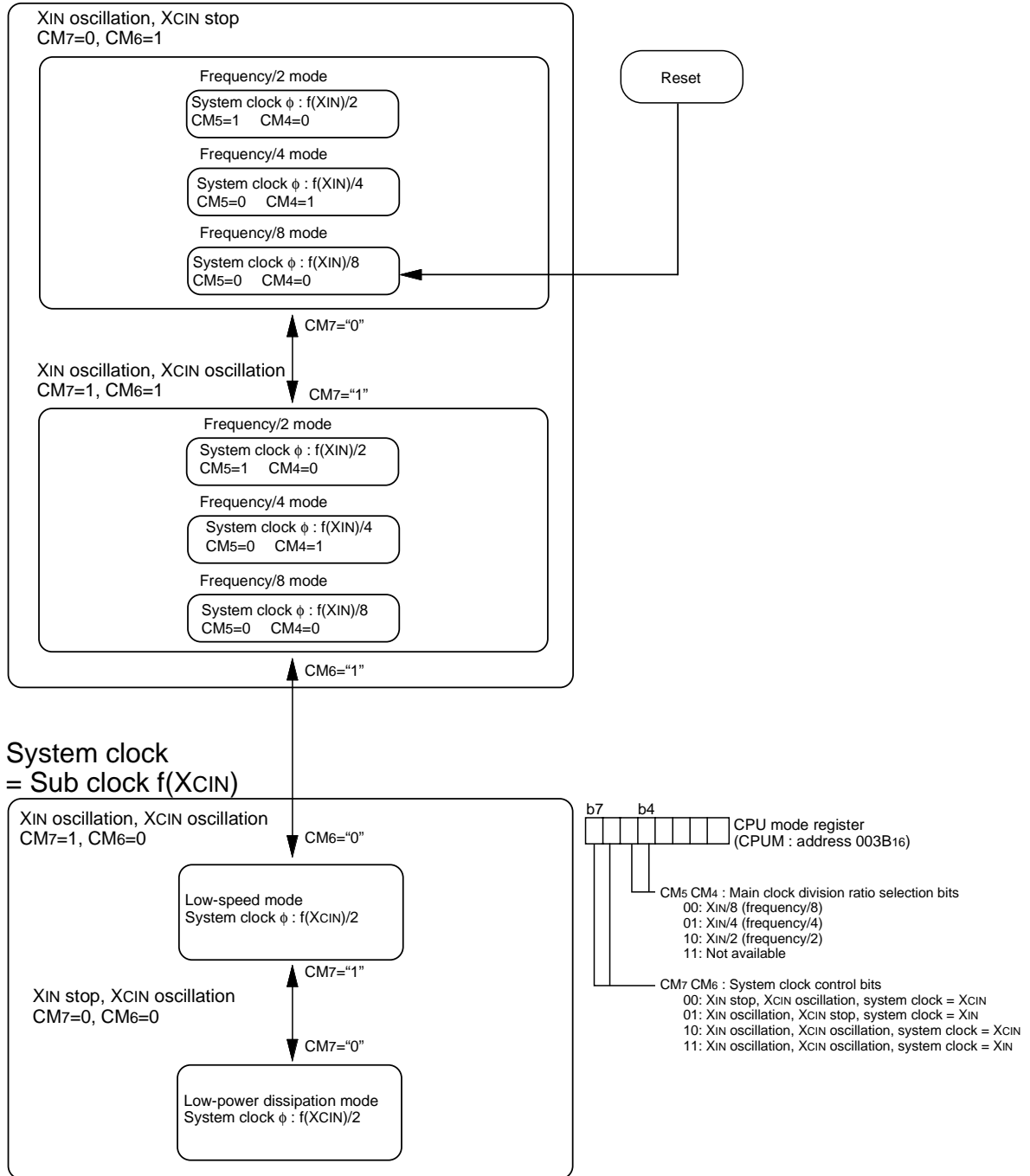

Fig. 52 Clock generating circuit block diagram

System clock = Main clock $f(XIN)$



- Notes**
- 1: When the mode is switched from frequency/2/4/8 to the low-speed mode, or the opposite is performed, change CM7 at first, and then, change CM6 after the oscillation of the changed mode is stabilized.
 - 2: The all modes can be switched to the stop mode or the wait mode and return to the source mode when the stop mode or the wait mode is ended.
 - 3: Timer and LCD operate in the wait mode.
 - 4: When the stop mode is ended, a delay time can be set by connecting timer 1 and timer 2.

Fig. 53 State transitions of system clock

Oscillation External Output Function

The 38C2 group has the oscillation external output function to output the rectangular waveform of the clock obtained by the oscillation circuits from P41 and P40.

In order to validate the oscillation external output function, set P40 or P41, or both to the output mode (set the corresponding direction register to "1").

The level of the XCOUT external output signal becomes "H" by the P40/P41 oscillation output control bits (bits 0 and 1) of the oscillation output control register (address 0FF0₁₆) in the following states;

- the function to output the signal from the XCOUT pin externally is selected
 - the sub clock (XCIN–XCOUT) is in the stop oscillating or stop mode.
- Likewise, the level of the XOUT external output signal becomes "H" by the P40/P41 oscillation output control bits (bits 0 and 1) of the oscillation output control register (address 0FF0₁₆) in the following states;
- the function to output the signal from the XOUT pin externally is selected
 - the main clock (XIN–XOUT) is in the stop oscillating or stop mode.

Note

When the signal from the XOUT pin or XCOUT pin of the oscillation circuit is input directly to the circuit except this MCU and used, the system operation may be unstabilized.

In order to share the oscillation circuit safely, use the clock output from P40 and P41 by this function for the circuits except this MCU.

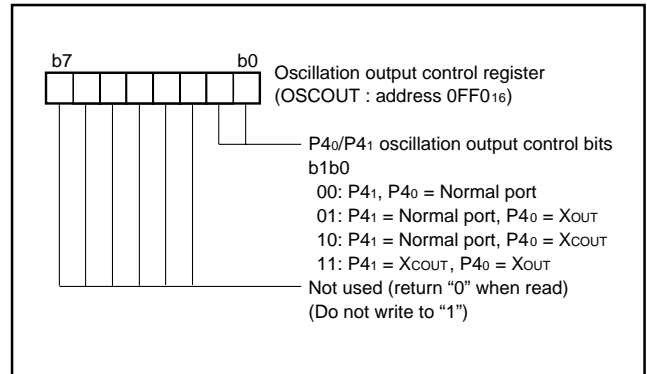

Fig. 54 Structure of oscillation output control register

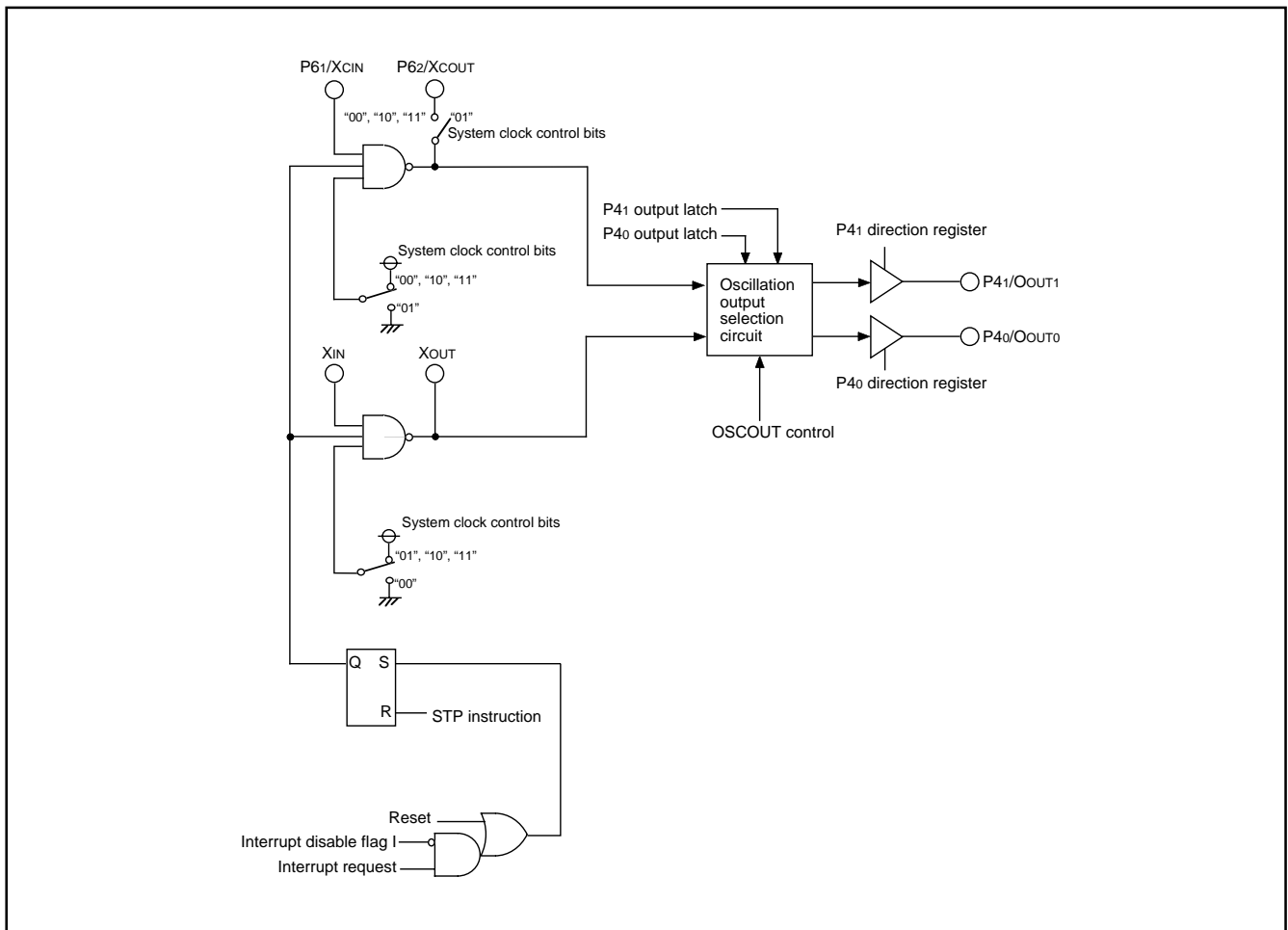

Fig. 55 Block diagram of Oscillation output function

NOTES ON PROGRAMMING

Processor Status Register

The contents of the processor status register (PS) after a reset are undefined, except for the interrupt disable flag (I) which is "1." After a reset, initialize flags which affect program execution. In particular, it is essential to initialize the index X mode (T) and the decimal mode (D) flags because of their effect on calculations.

Interrupts

The contents of the interrupt request bits do not change immediately after they have been written. After writing to an interrupt request register, execute at least one instruction before performing a BBC or BBS instruction.

Decimal Calculations

- To calculate in decimal notation, set the decimal mode flag (D) to "1," then execute an ADC or SBC instruction. After executing an ADC or SBC instruction, execute at least one instruction before executing an SEC, CLC, or CLD instruction.
- In decimal mode, the values of the negative (N), overflow (V), and zero (Z) flags are invalid.

Timers

- If a value n (between 0 and 255) is written to a timer latch, the frequency division ratio is $1/(n+1)$.
- The timers share the one frequency divider to generate the count source. Accordingly, when each timer starts operating, initializing the frequency divider is not executed. Therefore, when the frequency divider is selected for the count source, the delay of the maximum one cycle of the count source is generated until the timer starts counting or the waveform is output from timer starts operating. Also, the count source cannot be checked externally.

Multiplication and Division Instructions

- The index X mode (T) and the decimal mode (D) flags do not affect the MUL and DIV instruction.
- The execution of these instructions does not change the contents of the processor status register.

Ports

The contents of the port direction registers cannot be read. The following cannot be used:

- The data transfer instruction (LDA, etc.)
- The operation instruction when the index X mode flag (T) is "1"
- The addressing mode which uses the value of a direction register as an index
- The bit-test instruction (BBC or BBS, etc.) to a direction register
- The read-modify-write instructions (ROR, CLB, or SEB, etc.) to a direction register.

Use instructions such as LDM and STA, etc., to set the port direction registers.

Serial I/O

In clock synchronous serial I/O, if the receive side is using an external clock and it is to output the $\overline{\text{SRDY}}$ signal, set the transmit enable bit, the receive enable bit, and the $\overline{\text{SRDY}}$ output enable bit to "1."

Serial I/O continues to output the final bit from the TXD pin after transmission is completed.

A-D Converter

The comparator uses internal capacitors whose charge will be lost if the clock frequency is too low.

Therefore, set the A-D clock frequency to 250 kHz or more.

Also, when the STP instruction is executed during the A-D conversion, the A-D conversion is stopped immediately, the A-D conversion completion bit is set to "1", and the interrupt request is generated.

Instruction Execution Time

The instruction execution time is obtained by multiplying the number of cycles shown in the list of machine instructions by the period of the internal clock ϕ .

NOTES ON USE

VL3 pin

When LCD drive control circuit is not used, connect VL3 to VCC.

Countermeasures against noise

(1) Shortest wiring length

① Wiring for $\overline{\text{RESET}}$ pin

Make the length of wiring which is connected to the $\overline{\text{RESET}}$ pin as short as possible. Especially, connect a capacitor across the $\overline{\text{RESET}}$ pin and the Vss pin with the shortest possible wiring (within 20mm).

● Reason

The width of a pulse input into the $\overline{\text{RESET}}$ pin is determined by the timing necessary conditions. If noise having a shorter pulse width than the standard is input to the $\overline{\text{RESET}}$ pin, the reset is released before the internal state of the microcomputer is completely initialized. This may cause a program runaway.

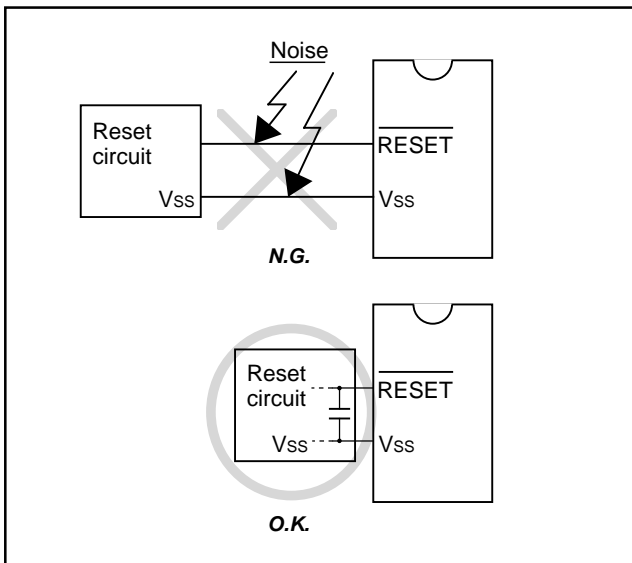

Fig. 56 Wiring for the RESET pin

② Wiring for clock input/output pins

- Make the length of wiring which is connected to clock I/O pins as short as possible.
- Make the length of wiring (within 20 mm) across the grounding lead of a capacitor which is connected to an oscillator and the Vss pin of a microcomputer as short as possible.
- Separate the Vss pattern only for oscillation from other Vss patterns.

● Reason

If noise enters clock I/O pins, clock waveforms may be deformed. This may cause a program failure or program runaway. Also, if a potential difference is caused by the noise between the Vss level of a microcomputer and the Vss level of an oscillator, the correct clock will not be input in the microcomputer.

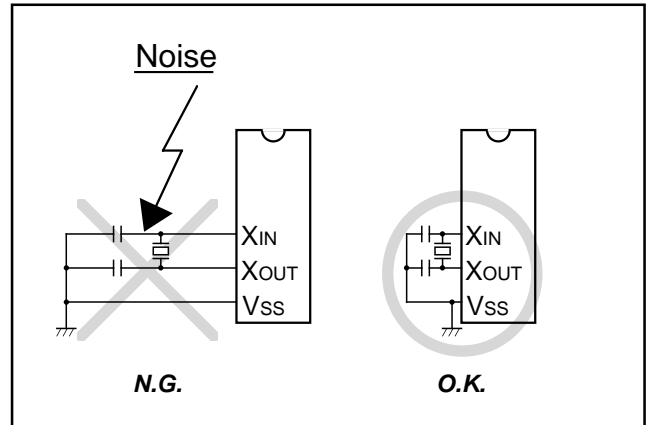

Fig. 57 Wiring for clock I/O pins

(2) Connection of bypass capacitor across Vss line and Vcc line
 Connect an approximately 0.1 μF bypass capacitor across the Vss line and the Vcc line as follows:

- Connect a bypass capacitor across the Vss pin and the Vcc pin at equal length.
- Connect a bypass capacitor across the Vss pin and the Vcc pin with the shortest possible wiring.
- Use lines with a larger diameter than other signal lines for Vss line and Vcc line.
- Connect the power source wiring via a bypass capacitor to the Vss pin and the Vcc pin.

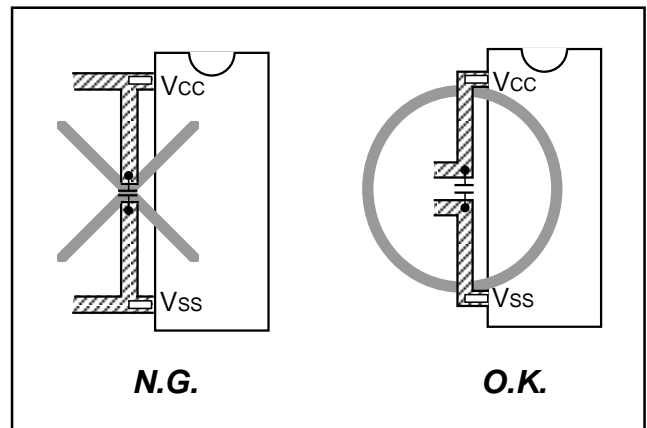

Fig. 58 Bypass capacitor across the Vss line and the Vcc line

(3) Oscillator concerns

Take care to prevent an oscillator that generates clocks for a microcomputer operation from being affected by other signals.

- ① Keeping oscillator away from large current signal lines
 Install a microcomputer (and especially an oscillator) as far as possible from signal lines where a current larger than the tolerance of current value flows.

● Reason

In the system using a microcomputer, there are signal lines for controlling motors, LEDs, and thermal heads or others. When a large current flows through those signal lines, strong noise occurs because of mutual inductance.

- ② Installing oscillator away from signal lines where potential levels change frequently

Install an oscillator and a connecting pattern of an oscillator away from signal lines where potential levels change frequently. Also, do not cross such signal lines over the clock lines or the signal lines which are sensitive to noise.

● Reason

Signal lines where potential levels change frequently (such as the CNTR pin signal line) may affect other lines at signal rising edge or falling edge. If such lines cross over a clock line, clock waveforms may be deformed, which causes a microcomputer failure or a program runaway.

(4) Wiring to VPP pin of flash memory version

Connect an approximately 10 kΩ resistor to the VPP pin the shortest possible in series and also to the VSS pin.

Note: Even when a circuit which included an approximately 10 kΩ resistor is used in the Mask ROM version, the microcomputer operates correctly.

● Reason

The VPP pin of the flash memory version is the power source input pin for the built-in flash memory. When programming/erasing in the built-in flash memory, the impedance of the VPP pin is low to allow the electric current for writing/erasing flow into the flash memory. Because of this, noise can enter easily. If noise enters the VPP pin, abnormal instruction codes or data are read from the built-in flash memory, which may cause a program runaway.

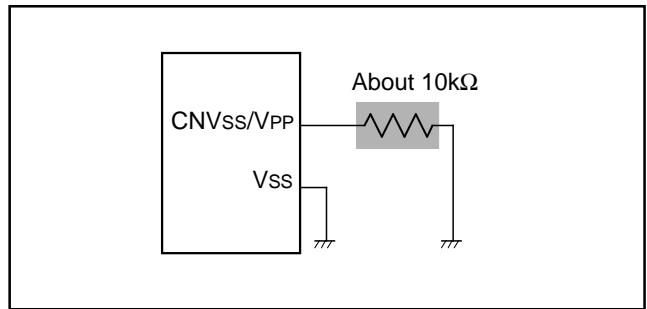

Fig. 60 Wiring for the VPP pin of flash memory

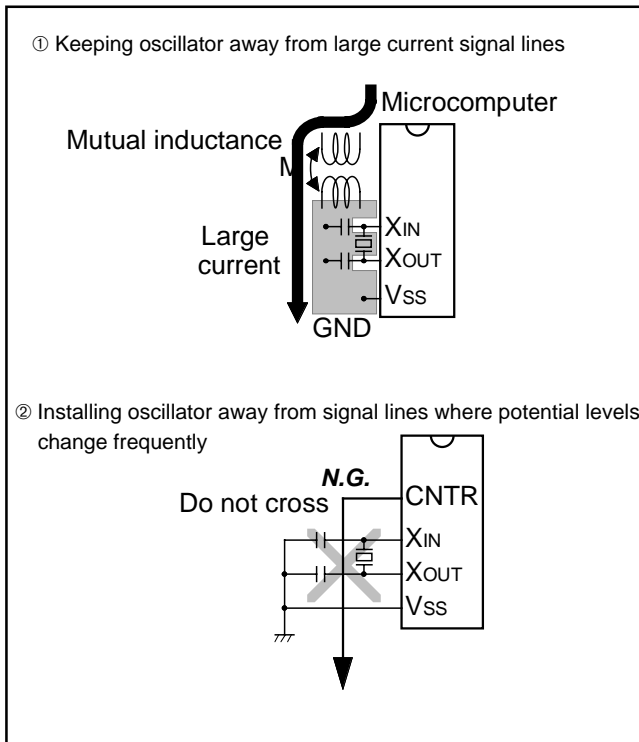

Fig. 59 Wiring for a large current signal line/Writing of signal lines where potential levels change frequently

Electric Characteristic Differences Between Mask ROM and Flash memory Version MCUs

There are differences in electric characteristics, operation margin, noise immunity, and noise radiation between the mask ROM and flash memory version MCUs due to the difference in the manufacturing processes.

When manufacturing an application system with the flash memory version and then switching to use of the mask ROM version, please perform sufficient evaluations for the commercial samples of the Mask ROM version.

Oscillation Circuit Constant

- (1) Determine an oscillation circuit constant after consulting the oscillator manufacturer about the matching characteristic evaluation.
- (2) Since oscillation circuit constants may be differences between the flash memory version and the mask ROM version, evaluate them, respectively.

FLASH MEMORY MODE

The 38C2 group (A version)'s flash memory version has an internal new DINOR (Divided bit line NOR) flash memory that can be rewritten with a single power source when Vcc is 4.5 to 5.5 V, and 2 power sources when Vcc is 3.0 to 4.5 V.

For this flash memory, three flash memory modes are available in which to read, program, and erase: the parallel I/O and standard serial I/O modes in which the flash memory can be manipulated using a programmer and the CPU rewrite mode in which the flash memory can be manipulated by the Central Processing Unit (CPU).

Summary

Table 11 lists the summary of the 38C2 group (A version)'s flash memory version.

This flash memory version has some blocks on the flash memory as shown in Figure 61 and each block can be erased.

In addition to the ordinary User ROM area to store the MCU operation control program, the flash memory has a Boot ROM area that is used to store a program to control rewriting in CPU rewrite and standard serial I/O modes. This Boot ROM area has had a standard serial I/O mode control program stored in it when shipped from the factory. However, the user can write a rewrite control program in this area that suits the user's application system. This Boot ROM area can be rewritten in only parallel I/O mode.

Table 11 Summary of 38C2 group (A version)'s flash memory version

Item		Specifications
Power source voltage (Vcc)		Vcc = 2.5 to 5.5 V (Note 1) Vcc = 2.5 to (Vcc at program/erase) + 0.5 V (Note 2)
Program/Erase VPP voltage (VPP)		VPP = 4.5 to 5.5 V, Vcc = 3.0 to 5.5 V
Flash memory mode		3 modes; Parallel I/O mode, Standard serial I/O mode, CPU rewrite mode
Erase block division	User ROM area	Refer to Fig. 61.
	Boot ROM area	Not divided (4K bytes) (Note 3)
Program method		In units of bytes
Erase method		Block erase
Program/Erase control method		Program/Erase control by software command
Number of commands		5 commands
Number of program/Erase times		100 times
ROM code protection		Available in parallel I/O mode and standard serial I/O mode

Notes 1: It is the rating value when Vcc = 5.0 to 5.5 V at program/erase.

2: It is the rating value when Vcc = 3.0 to 5.0 V at program/erase.

3: The Boot ROM area has had a standard serial I/O mode control program stored in it when shipped from the factory. This Boot ROM area can be erased and written in only parallel I/O mode.

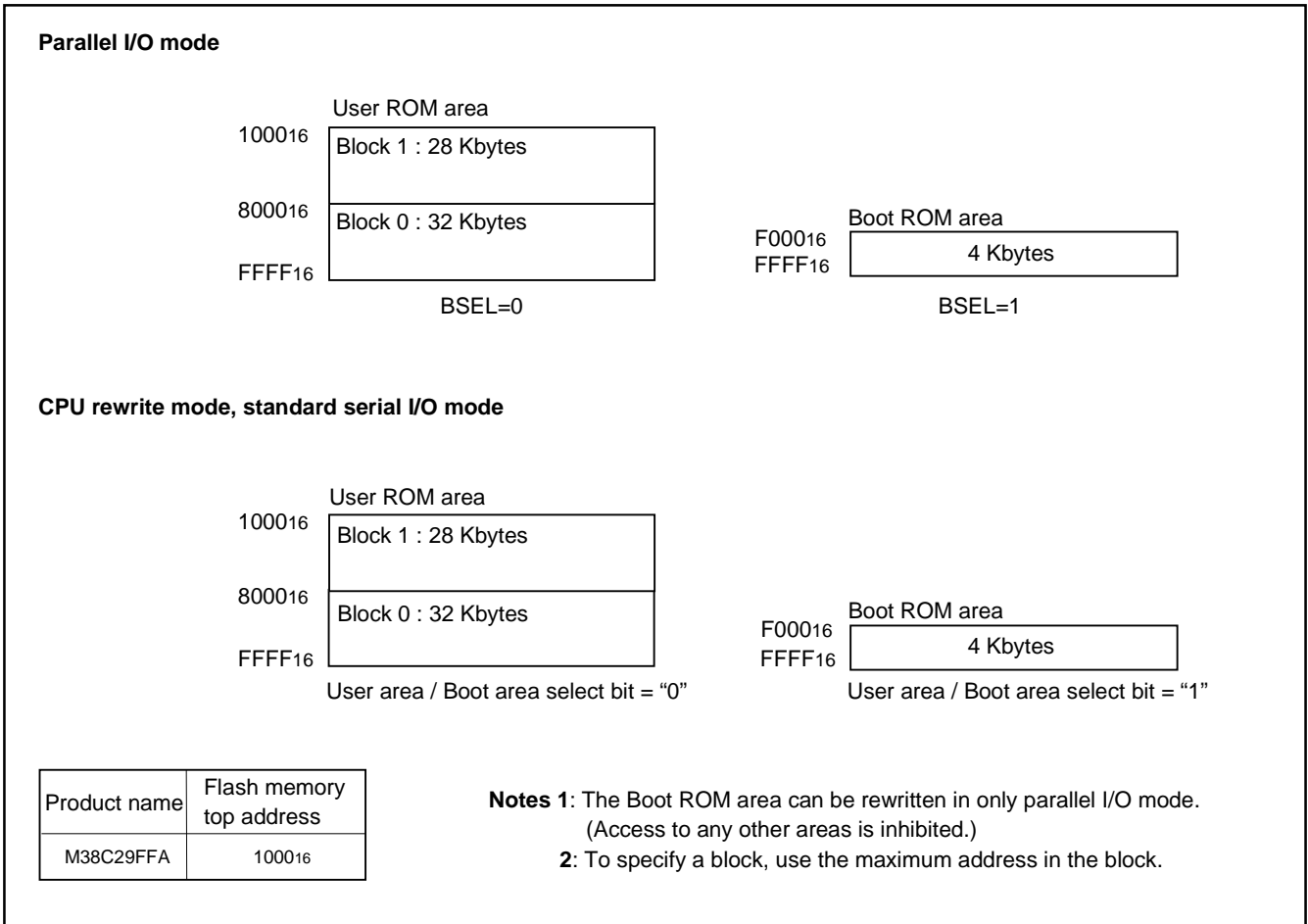

Fig. 61 Block diagram of built-in flash memory

(1) CPU Rewrite Mode

In CPU rewrite mode, the internal flash memory can be operated on (read, program, or erase) under control of the Central Processing Unit (CPU).

In CPU rewrite mode, only the User ROM area shown in Figure 61 can be rewritten; the Boot ROM area cannot be rewritten. Make sure the program and block erase commands are issued for only the User ROM area and each block area.

The control program for CPU rewrite mode can be stored in either User ROM or Boot ROM area. In the CPU rewrite mode, because the flash memory cannot be read from the CPU, the rewrite control program must be transferred to internal RAM area before it can be executed.

Boot Mode

The control program for CPU rewrite mode must be written into the User ROM or Boot ROM area in parallel I/O mode beforehand. (If the control program is written into the Boot ROM area, the standard serial I/O mode becomes unusable.)

See Figure 61 for details about the Boot ROM area.

Normal microcomputer mode is entered when the microcomputer is reset with pulling CNV_{SS} pin low. In this case, the CPU starts operating using the control program in the User ROM area.

When the microcomputer is reset by pulling the P4₁(\overline{CE}) pin high, the CNV_{SS} pin high, the CPU starts operating (start address of program is stored into addresses FFFC₁₆ and FFFD₁₆) using the control program in the Boot ROM area. This mode is called the "Boot mode". Also, User ROM area can be rewritten using the control program in the Boot ROM area.

Block Address

Block addresses refer to the maximum address of each block. These addresses are used in the block erase command.

Outline Performance (CPU Rewrite Mode)

CPU rewrite mode is usable in the single-chip or Boot mode. The only User ROM area can be rewritten.

In CPU rewrite mode, the CPU erases, programs and reads the internal flash memory as instructed by software commands. This rewrite control program must be transferred to internal RAM area before it can be executed.

The MCU enters CPU rewrite mode by applying 4.5 V to 5.5 V to the CNVSS pin and setting "1" to the CPU rewrite mode select bit (bit 1 of address 0FFE₁₆). Then, software commands can be accepted.

Use software commands to control program and erase operations. Whether a program or erase operation has terminated normally or in error can be verified by reading the status register.

Figure 62 shows the flash memory control register.

Bit 0 of the flash memory control register is the RY/ $\overline{\text{BY}}$ status flag used exclusively to read the operating status of the flash memory. During programming and erase operations, it is "0" (busy). Otherwise, it is "1" (ready).

Bit 1 of the flash memory control register is the CPU rewrite mode select bit. When this bit is set to "1", the MCU enters CPU rewrite mode. And then, software commands can be accepted. In CPU re-

write mode, the CPU becomes unable to access the internal flash memory directly. Therefore, use the control program in the internal RAM for write to bit 1. To set this bit 1 to "1", it is necessary to write "0" and then write "1" in succession to bit 1. The bit can be set to "0" by only writing "0".

Bit 2 of the flash memory control register is the CPU rewrite mode entry flag. This flag indicates "1" in CPU rewrite mode, so that reading this flag can check whether CPU rewrite mode has been entered or not.

Bit 3 of the flash memory control register is the flash memory reset bit used to reset the control circuit of internal flash memory. This bit is used when exiting CPU rewrite mode and when flash memory access has failed. When the CPU rewrite mode select bit is "1", setting "1" for this bit resets the control circuit. To release the reset, it is necessary to set this bit to "0".

Bit 4 of the flash memory control register is the User area/Boot area select bit. When this bit is set to "1", Boot ROM area is accessed, and CPU rewrite mode in Boot ROM area is available. In Boot mode, this bit is set to "1" automatically. Programming of this bit must be executed on program of the internal RAM.

Figure 63 shows a flowchart for setting/releasing CPU rewrite mode.

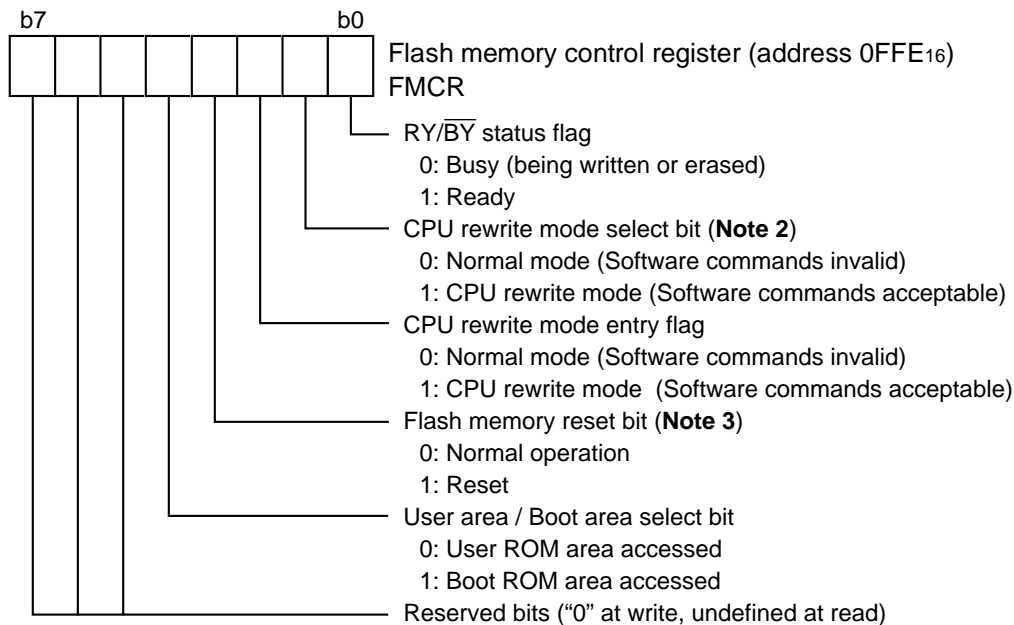

- Notes**
- 1:** The contents of flash memory control register are "XXX00001" just after reset release.
 - 2:** For this bit to be set to "1", the user needs to write "0" and then "1" to it in succession. Use the control program in the RAM for write to this bit.
 - 3:** This bit is valid when the CPU rewrite mode select bit is "1". Set this bit 3 to "0" subsequently after setting bit 3 to "1".

Fig. 62 Structure of flash memory control register

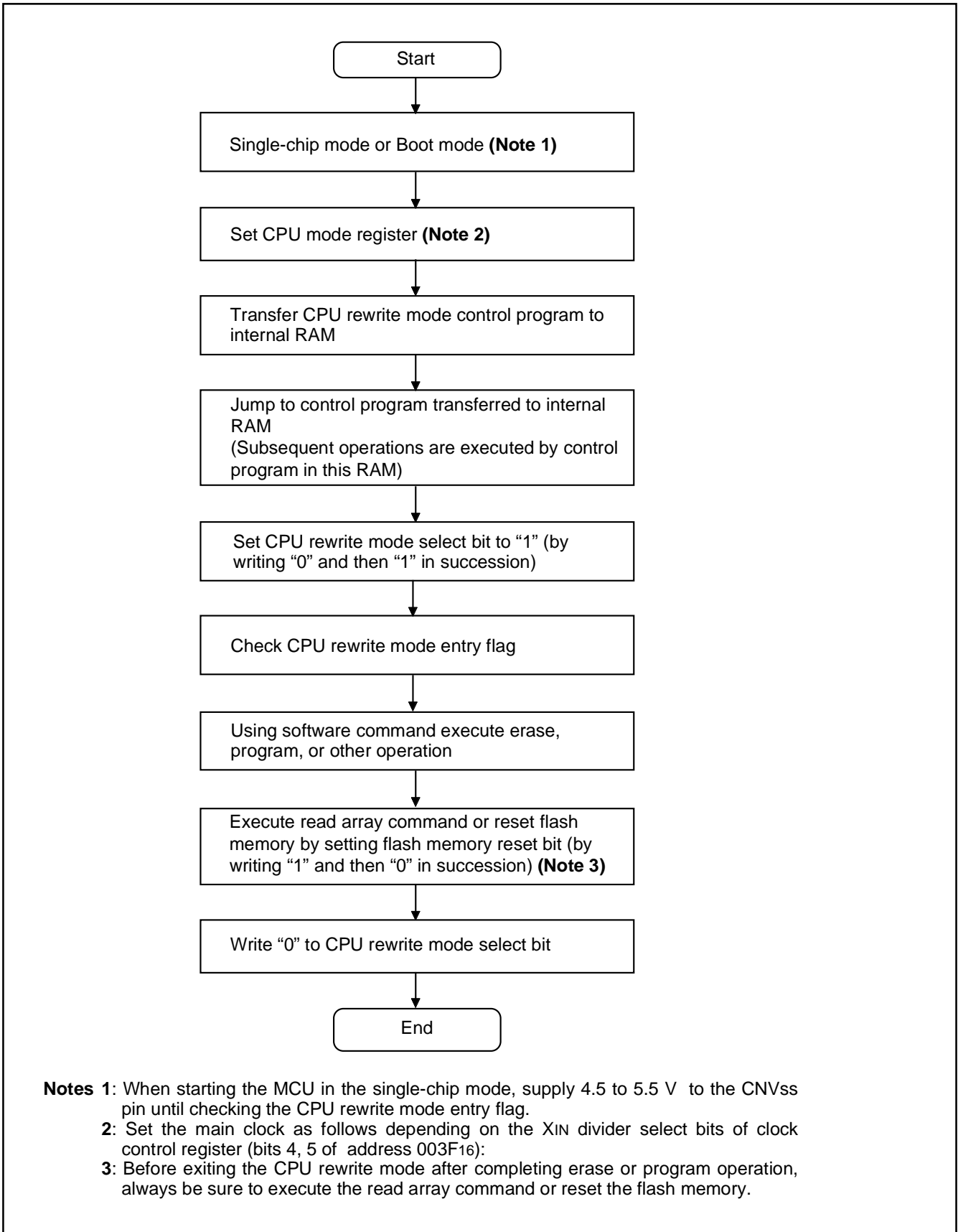

- Notes 1:** When starting the MCU in the single-chip mode, supply 4.5 to 5.5 V to the CNVss pin until checking the CPU rewrite mode entry flag.
- 2:** Set the main clock as follows depending on the X1N divider select bits of clock control register (bits 4, 5 of address 003F16):
- 3:** Before exiting the CPU rewrite mode after completing erase or program operation, always be sure to execute the read array command or reset the flash memory.

Fig. 63 CPU rewrite mode set/release flowchart

Notes on CPU Rewrite Mode

Take the notes described below when rewriting the flash memory in CPU rewrite mode.

●Operation speed

During CPU rewrite mode, set the system clock ϕ to 4.0 MHz or less using the main clock division ratio selection bits (bits 4 and 5 of address 003B16).

●Instructions inhibited against use

The instructions which refer to the internal data of the flash memory cannot be used during CPU rewrite mode.

●Interrupts inhibited against use

The interrupts cannot be used during CPU rewrite mode because they refer to the internal data of the flash memory.

●Watchdog timer

If the watchdog timer has been already activated, internal reset due to an underflow will not occur because the watchdog timer is surely cleared during program or erase.

●Reset

Reset is always valid. The MCU is activated using the boot mode at release of reset in the condition of CNVss = "H", so that the program will begin at the address which is stored in addresses FFFC16 and FFFD16 of the boot ROM area.

Software Commands

Table 12 lists the software commands.

After setting the CPU rewrite mode select bit to "1", execute a software command to specify an erase or program operation.

Each software command is explained below.

●Read Array Command (FF16)

The read array mode is entered by writing the command code "FF16" in the first bus cycle. When an address to be read is input in one of the bus cycles that follow, the contents of the specified address are read out at the data bus (D0 to D7). The read array mode is retained until another command is written.

●Read Status Register Command (7016)

When the command code "7016" is written in the first bus cycle, the contents of the status register are read out at the data bus (D0 to D7) by a read in the second bus cycle.

The status register is explained in the next section.

●Clear Status Register Command (5016)

This command is used to clear the bits SR4 and SR5 of the status register after they have been set. These bits indicate that operation has ended in an error. To use this command, write the command code "5016" in the first bus cycle.

●Program Command (4016)

Program operation starts when the command code "4016" is written in the first bus cycle. Then, if the address and data to program are written in the 2nd bus cycle, program operation (data programming and verification) will start.

Whether the write operation is completed can be confirmed by read status register or the RY/B \bar{Y} status flag. When the program starts, the read status register mode is entered automatically and the contents of the status register is read at the data bus (D0 to D7). The status register bit 7 (SR7) is set to "0" at the same time the write operation starts and is returned to "1" upon completion of the write operation. In this case, the read status register mode remains active until the read array command (FF16) is written.

The RY/B \bar{Y} status flag of the flash memory control register is "0" during write operation and "1" when the write operation is completed as is the status register bit 7.

At program end, program results can be checked by reading the status register.

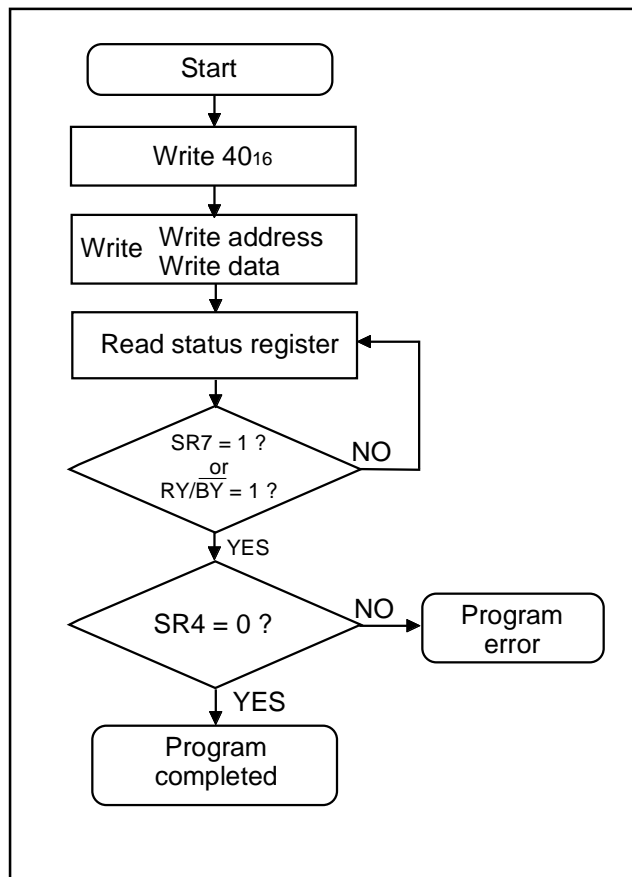

Fig. 64 Program flowchart

Table 12 List of software commands (CPU rewrite mode)

Command	Cycle number	First bus cycle			Second bus cycle		
		Mode	Address	Data (D0 to D7)	Mode	Address	Data (D0 to D7)
Read array	1	Write	X (Note 4)	FF16			
Read status register	2	Write	X	7016	Read	X	SRD (Note 1)
Clear status register	1	Write	X	5016			
Program	2	Write	X	4016	Write	WA (Note 2)	WD (Note 2)
Block erase	2	Write	X	2016	Write	BA (Note 3)	D016

Notes 1: SRD = Status Register Data

2: WA = Write Address, WD = Write Data

3: BA = Block Address to be erased (Input the maximum address of each block.)

4: X denotes a given address in the User ROM area.

●**Block Erase Command (20₁₆/D0₁₆)**

By writing the command code "20₁₆" in the first bus cycle and the confirmation command code "D0₁₆" and the block address in the second bus cycle that follows, the block erase (erase and erase verify) operation starts for the block address of the flash memory to be specified.

Whether the block erase operation is completed can be confirmed by read status register or the RY/ $\overline{\text{BY}}$ status flag of flash memory control register. At the same time the block erase operation starts, the read status register mode is automatically entered, so that the contents of the status register can be read out. The status register bit 7 (SR7) is set to "0" at the same time the block erase operation starts and is returned to "1" upon completion of the block erase operation. In this case, the read status register mode remains active until the read array command (FF₁₆) is written.

The RY/ $\overline{\text{BY}}$ status flag is "0" during block erase operation and "1" when the block erase operation is completed as is the status register bit 7.

After the block erase ends, erase results can be checked by reading the status register. For details, refer to the section where the status register is detailed.

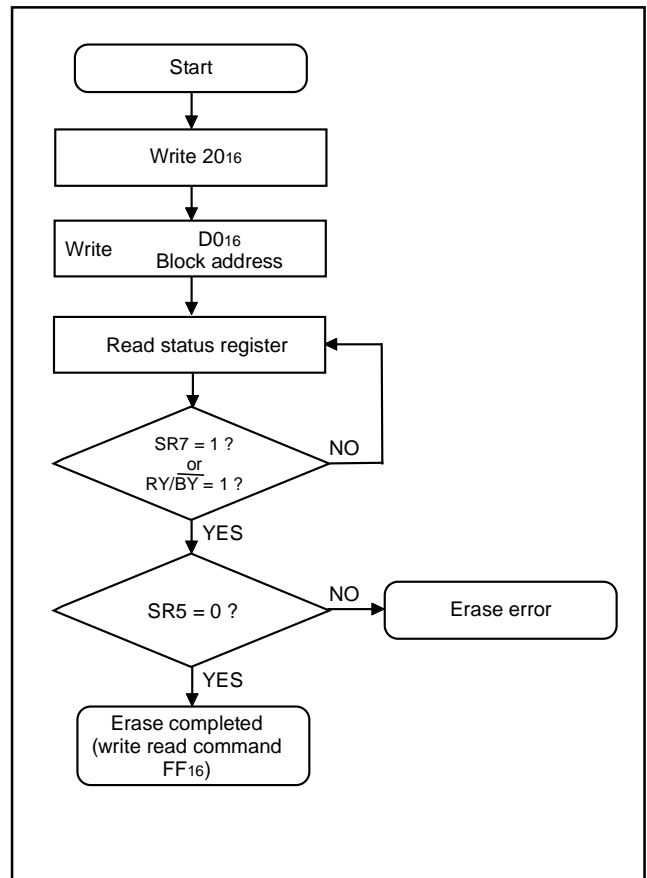

Fig. 65 Erase flowchart

Status Register

The status register shows the operating status of the flash memory and whether erase operations and programs ended successfully or in error. It can be read in the following ways:

- (1) By reading an arbitrary address from the User ROM area after writing the read status register command (70₁₆)
- (2) By reading an arbitrary address from the User ROM area in the period from when the program starts or erase operation starts to when the read array command (FF₁₆) is input.

Also, the status register can be cleared by writing the clear status register command (50₁₆).

After reset, the status register is set to "80₁₆".

Table 13 shows the status register. Each bit in this register is explained below.

•Sequencer status (SR7)

The sequencer status indicates the operating status of the flash memory. This bit is set to "0" (busy) during write or erase operation and is set to "1" when these operations ends.

After power-on, the sequencer status is set to "1" (ready).

•Erase status (SR5)

The erase status indicates the operating status of erase operation. If an erase error occurs, it is set to "1". When the erase status is cleared, it is reset to "0".

•Program status (SR4)

The program status indicates the operating status of write operation. When a write error occurs, it is set to "1". The program status is reset to "0" when it is cleared.

If "1" is written for any of the SR5 and SR4 bits, the read array, program, and block erase commands are not accepted. Before executing these commands, execute the clear status register command (50₁₆) and clear the status register.

Also, if any commands are not correct, both SR5 and SR4 are set to "1".

Table 13 Definition of each bit in status register

Each bit of SRD bits	Status name	Definition	
		"1"	"0"
SR7 (bit7)	Sequencer status	Ready	Busy
SR6 (bit6)	Reserved	-	-
SR5 (bit5)	Erase status	Terminated normally	Terminated normally
SR4 (bit4)	Program status	Terminated normally	Terminated normally
SR3 (bit3)	Reserved	-	-
SR2 (bit2)	Reserved	-	-
SR1 (bit1)	Reserved	-	-
SR0 (bit0)	Reserved	-	-

Full Status Check

By performing full status check, it is possible to know the execution results of erase and program operations. Figure 66 shows a full status check flowchart and the action to be taken when each error occurs.

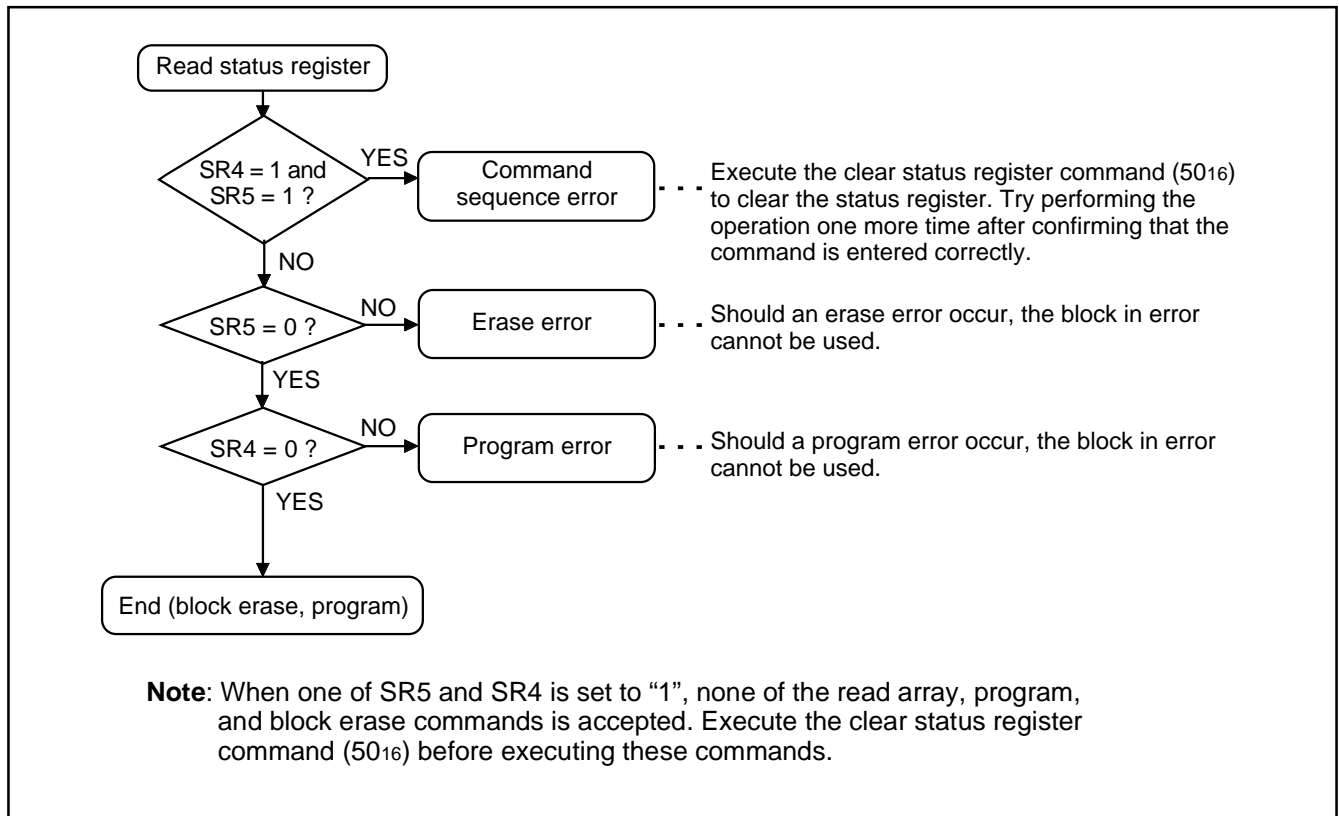

Fig. 66 Full status check flowchart and remedial procedure for errors

Functions To Inhibit Rewriting Flash Memory Version

To prevent the contents of internal flash memory from being read out or rewritten easily, this MCU incorporates a ROM code protect function for use in parallel I/O mode and an ID code check function for use in standard serial I/O mode.

●ROM Code Protect Function

The ROM code protect function is the function to inhibit reading out or modifying the contents of internal flash memory by using the ROM code protect control address (address FFDB₁₆) in parallel I/O mode. Figure 67 shows the ROM code protect control address (address FFDB₁₆). (This address exists in the User ROM area.)

If one or both of the pair of ROM code protect bits is set to “0”, the ROM code protect is turned on, so that the contents of internal flash memory are protected against readout and modification. The ROM code protect is implemented in two levels. If level 2 is selected, the flash memory is protected even against readout by a shipment inspection LSI tester, etc. When an attempt is made to select both level 1 and level 2, level 2 is selected by default. If both of the two ROM code protect reset bits are set to “00”, the ROM code protect is turned off, so that the contents of internal flash memory can be readout or modified. Once the ROM code protect is turned on, the contents of the ROM code protect reset bits cannot be modified in parallel I/O mode. Use the serial I/O or CPU rewrite mode to rewrite the contents of the ROM code protect reset bits.

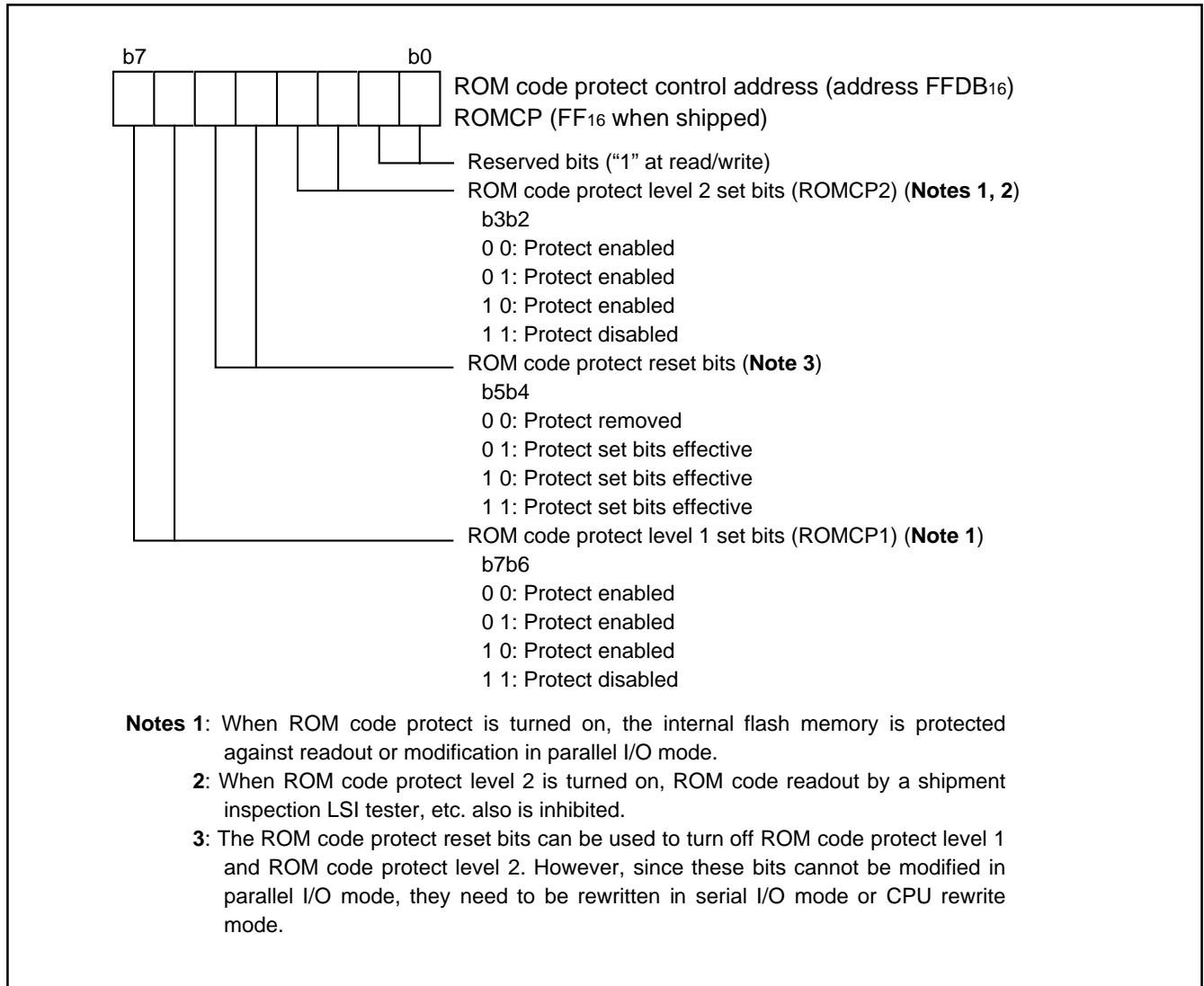

Fig. 67 Structure of ROM code protect control address

ID Code Check Function

Use this function in standard serial I/O mode. When the contents of the flash memory are not blank, the ID code sent from the programmer is compared with the ID code written in the flash memory to see if they match. If the ID codes do not match, the commands sent from the programmer are not accepted. The ID code consists of 8-bit data, and its areas are FFD4₁₆ to FFDA₁₆. Write a program which has had the ID code preset at these addresses to the flash memory.

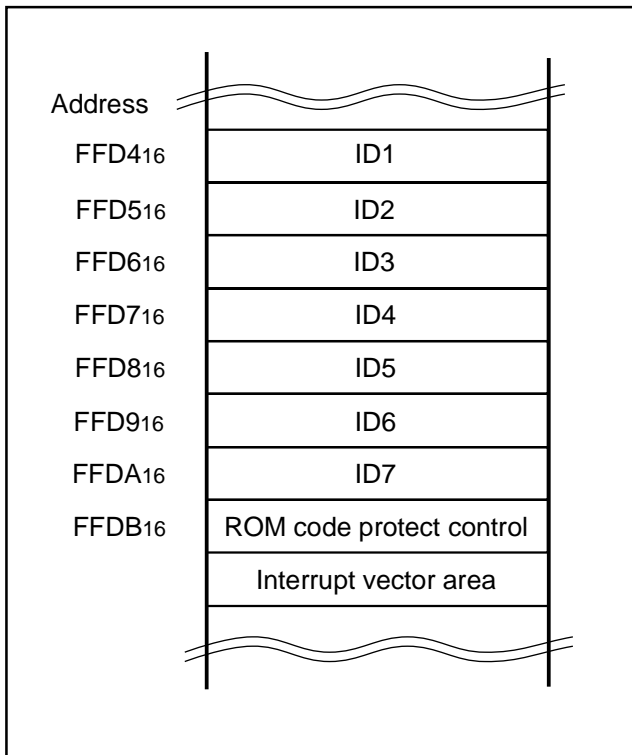

Fig. 68 ID code store addresses

(2) Parallel I/O Mode

The parallel I/O mode is used to input/output software commands, address and data in parallel for operation (read, program and erase) to internal flash memory.

Use the external device (writer) only for 38C2 Group group (A version)'s flash memory version. For details, refer to the user's manual of each writer manufacturer.

User ROM and Boot ROM Areas

In parallel I/O mode, the User ROM and Boot ROM areas shown in Figure 61 can be rewritten. Both areas of flash memory can be operated on in the same way.

Program and block erase operations can be performed only in the User ROM area.

The Boot ROM area is 4 Kbytes in size and located at addresses F000₁₆ through FFFF₁₆. Make sure program and block erase operations are always performed within this address range. (Access to any location outside this address range is prohibited.)

In the Boot ROM area, an erase block operation is applied to only one 4 Kbyte block. The boot ROM area has had a standard serial I/O mode control program stored in it when shipped from the Mitsubishi factory. Therefore, using the MCU in standard serial I/O mode, do not rewrite to the Boot ROM area.

(3) Standard serial I/O Mode

The standard serial I/O mode inputs and outputs the software commands, addresses and data needed to operate (read, program, erase, etc.) the internal flash memory. This I/O is clock synchronized serial. This mode requires a purpose-specific peripheral unit.

The standard serial I/O mode is different from the parallel I/O mode in that the CPU controls flash memory rewrite (uses the CPU rewrite mode), rewrite data input and so forth. The standard serial I/O mode is started by connecting "H" to the P41 (\overline{CE}) pin and "H" to the CNVSS pin (when $V_{CC} = 4.5$ to 5.5 V, connect to V_{CC} , and when $V_{CC} = 3.0$ to 4.5 V, apply 4.5 V to 5.5 V to V_{pp} from an external source), and releasing the reset operation. (In the ordinary microcomputer mode, set CNVSS pin to "L" level.)

This control program is written in the Boot ROM area when the product is shipped from Mitsubishi. Accordingly, make note of the fact that the standard serial I/O mode cannot be used if the Boot ROM area is rewritten in parallel I/O mode. Figure 69 shows the pin connections for the standard serial I/O mode.

In standard serial I/O mode, serial data I/O uses the four UART2 pins SCLK2, RxD2, TxD2 and $\overline{SRDY2}$ (BUSY). The SCLK2 pin is the transfer clock input pin through which an external transfer clock is input. The TxD2 pin is for CMOS output. The $\overline{SRDY2}$ (BUSY) pin outputs "L" level when ready for reception and "H" level when reception starts.

Serial data I/O is transferred serially in 8-bit units.

In standard serial I/O mode, only the User ROM area shown in Figure 61 can be rewritten. The Boot ROM area cannot.

In standard serial I/O mode, a 7-byte ID code is used. When there is data in the flash memory, commands sent from the peripheral unit (programmer) are not accepted unless the ID code matches.

Outline Performance (Standard Serial I/O Mode)

In standard serial I/O mode, software commands, addresses and data are input and output between the MCU and peripheral units (serial programmer, etc.) using 4-wire clock-synchronized serial I/O (UART2).

In reception, software commands, addresses and program data are synchronized with the rise of the transfer clock that is input to the SCLK2 pin, and are then input to the MCU via the RxD2 pin. In transmission, the read data and status are synchronized with the fall of the transfer clock, and output from the TxD2 pin.

The TxD2 pin is for CMOS output. Transfer is in 8-bit units with LSB first.

When busy, such as during transmission, reception, erasing or program execution, the $\overline{SRDY2}$ (BUSY) pin is "H" level. Accordingly, always start the next transfer after the $\overline{SRDY2}$ (BUSY) pin is "L" level.

Also, data and status registers in a memory can be read after inputting software commands. Status, such as the operating state of the flash memory or whether a program or erase operation ended successfully or not, can be checked by reading the status register. Here following explains software commands, status registers, etc.

Table 14 Description of pin function (Flash Memory Serial I/O Mode)

Pin name	Signal name	I/O	Function
VCC,VSS	Power supply		Apply guaranteed voltage of program/erase to the Vcc pin and 0 V to the Vss pin.
CNVSS	CNVSS	I	Connect this pin to Vcc at Vcc = 4.5 to 5.5 V. Connect this pin to VPP at Vcc = 3.0 to 4.5 V.
RESET	Reset input	I	Reset input pin. When XIN oscillation is stable, input "L" level for 2 μs or more.
XIN	Clock input	I	Connect a ceramic resonator or crystal oscillator between the XIN and XOUT pins. When entering an externally driven clock, enter it from XIN and input the inverted signal of XIN pin to XOUT pin.
XOUT	Clock output	O	
AVSS	Analog power supply		Connect to Vss.
VREF	Analog reference voltage	I	Apply reference voltage of A-D to this pin.
P00–P07	I/O port P0	I/O	Input "L" or "H" level, or keep open.
P10–P17	I/O port P1	I/O	Input "L" or "H" level, or keep open.
P20–P27	I/O port P2	I/O	Input "L" or "H" level, or keep open.
P30	BUSY output	O	BUSY signal output pin.
P31	SCLK input	I	Serial clock input pin.
P32	TXD output	O	Serial data output pin.
P33	RXD input	I	Serial data input pin.
P34–P37	I/O port P3	I/O	Input "L" or "H" level, or keep open.
P40	I/O port P4	I/O	Input "L" or "H" level, or keep open.
P41	\overline{CE} input	I	Input "H" level.
P42–P47	I/O port P4	I/O	Input "L" or "H" level, or keep open.
P50–P57	I/O port P5	I/O	Input "L" or "H" level, or keep open.
P60	I/O port P6	I/O	Input "L" or "H" level, or keep open.
P61/XCIN	I/O port P6/Sub clock input	I/O	When these pins are used for sub-clock, connect a quartz-crystal oscillator between the XCIN and XOUT pins.
P62/XCOUT	I/O port P6/Sub clock output	I/O	When entering an externally driven clock, enter it from XCIN and leave XOUT open. When these pins are used as port, input "L" or "H" level, or keep open.
COM0–COM3	Common output	O	When the LCD control circuit is not used, keep open.
VL3	Power supply for LCD		Apply LCD power source to this pin. When the LCD drive control circuit is not used, connect this pin to Vcc.

PRELIMINARY
 Notice: This is not a final specification.
 Some parametric limits are subject to
 change.

MITSUBISHI MICROCOMPUTERS 38C2 Group (A Version)

SINGLE-CHIP 8-BIT CMOS MICROCOMPUTER

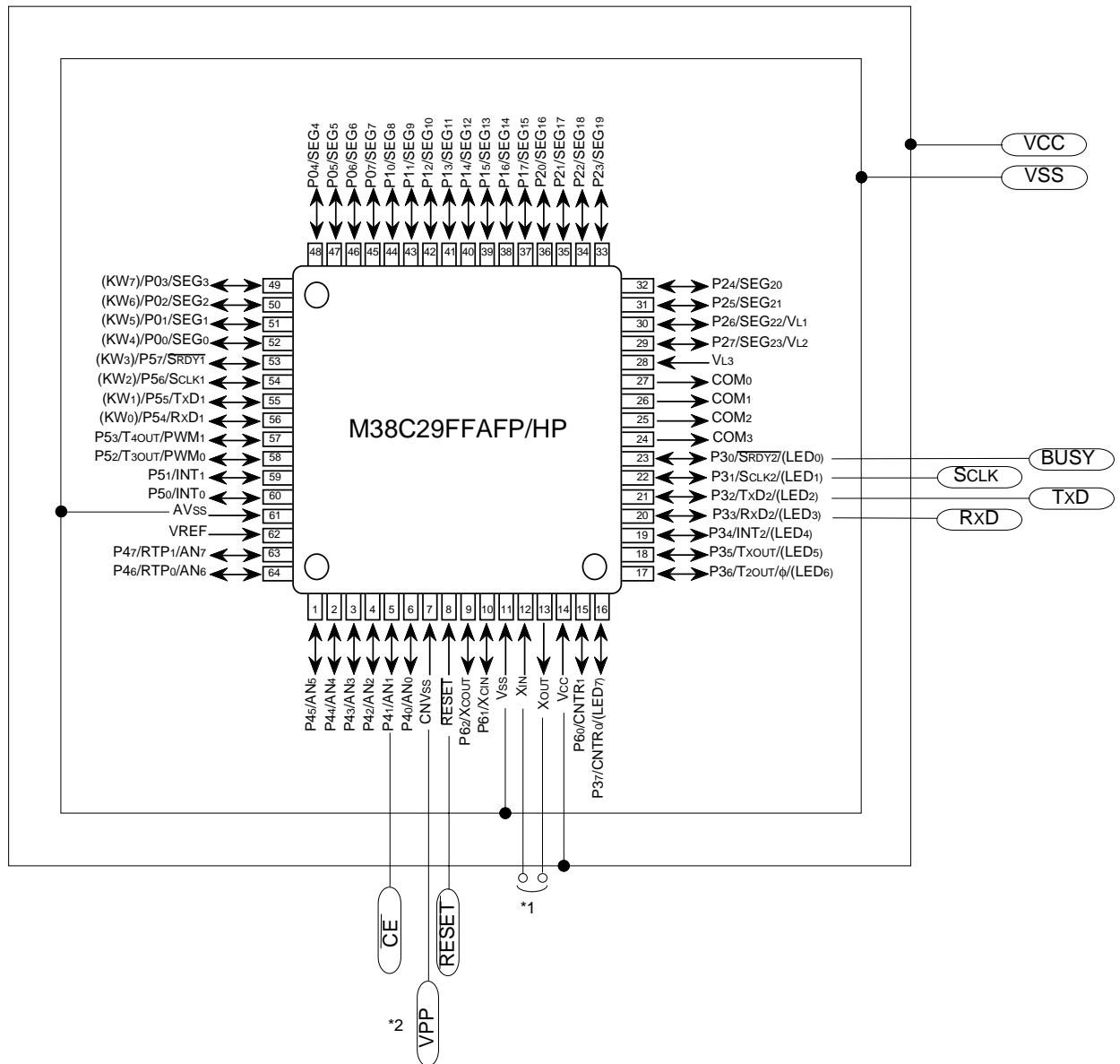

Mode setup method

Signal	Value
CNVss	4.5 to 5.5 V
CE	Vcc
RESET	Vss → Vcc

64P6U-A/64P6Q-A

- *1. Connect to oscillation circuit.
- *2. Connect to Vcc when Vcc=4.5 to 5.5V.
 Connect to VPP (=4.5 to 5.5V) when Vcc=3.0 to 4.5V.

Fig. 69 Pin connection diagram in serial I/O mode

Software Commands

Table 15 lists software commands. In standard serial I/O mode, erase, program and read are controlled by transferring software commands via the Rx/D pin. Software commands are explained

here below. Basically, the software commands of the standard serial I/O mode are the same as that of the parallel I/O mode, but 4 commands are added: ID check, download, version data output and Boot ROM area output functions.

Table 15 Software commands (Standard serial I/O mode)

Control command	1st byte transfer	2nd byte	3rd byte	4th byte	5th byte	6th byte	When ID is not verified
1 Page read	FF ₁₆	Address (middle)	Address (high)	Data output	Data output	Data output	Data output to 259th byte	Not acceptable
2 Page program	41 ₁₆	Address (middle)	Address (high)	Data input	Data input	Data input	Data input to 259th byte	Not acceptable
3 Block erase	20 ₁₆	Address (middle)	Address (high)	D0 ₁₆				Not acceptable
4 Erase all blocks	A7 ₁₆	D0 ₁₆						Not acceptable
5 Read status register	70 ₁₆	SRD output	SRD1 output					Acceptable
6 Clear status register	50 ₁₆							Not acceptable
7 ID check	F5 ₁₆	Address (low)	Address (middle)	Address (high)	ID size	ID1	To ID7	Acceptable
8 Download function	FA ₁₆	Size (low)	Size (high)	Check-sum	Data input	To required number of times		Not acceptable
9 Version data output function	FB ₁₆	Version data output	Version data output	Version data output	Version data output	Version data output	Version data output to 9th byte	Acceptable
10 Boot ROM area output function	FC ₁₆	Address (middle)	Address (high)	Data output	Data output	Data output	Data output to 259th byte	Not acceptable

Notes 1: Shading indicates transfer from the internal flash memory microcomputer to a programmer. All other data is transferred from a programmer to the internal flash memory microcomputer.

2: SRD refers to status register data. SRD1 refers to status register 1 data.

3: All commands can be accepted when the flash memory is totally blank.

4: "Address (high)" means A₁₆ to A₂₃ and are always set to "00₁₆".

"Address (middle)" means A₈ to A₁₅.

"Address (low)" means A₀ to A₇.

●Page Read Command

This command reads the specified page (256 bytes) in the flash memory sequentially one byte at a time. Execute the page read command as explained here following.

- (1) Transfer the "FF16" command code with the 1st byte.
- (2) Transfer addresses A8 to A15 and A16 to A23 with the 2nd and 3rd bytes respectively.
- (3) From the 4th byte onward, data (D0 to D7) for the page (256 bytes) specified with addresses A8 to A23 will be output sequentially from the smallest address first synchronized with the fall of the clock.

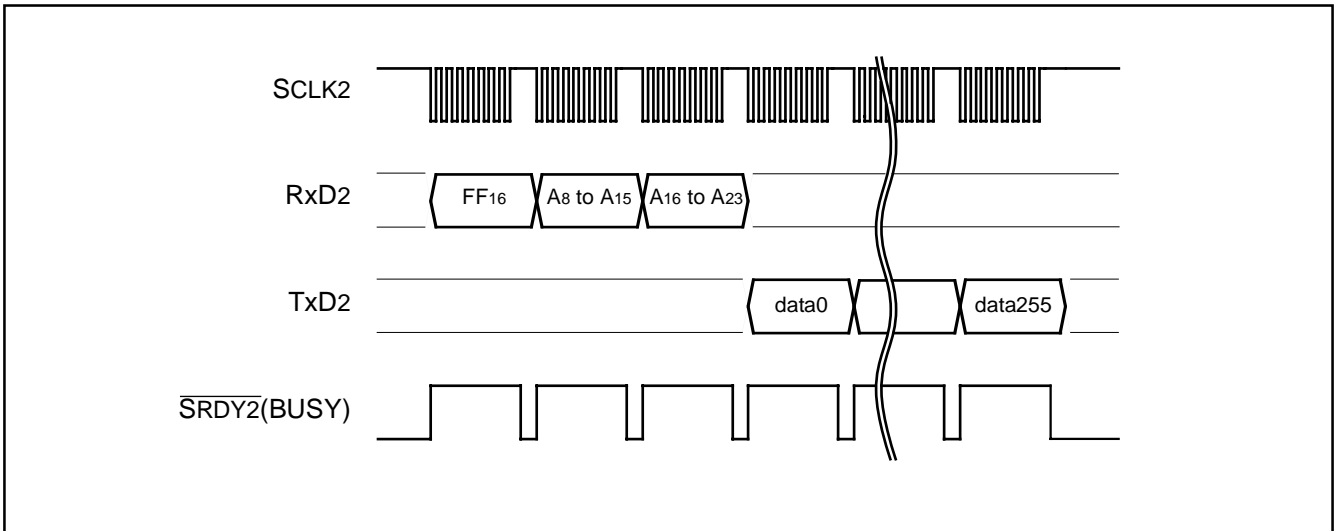

Fig. 70 Timing for page read

●Read Status Register Command

This command reads status information. When the "7016" command code is transferred with the 1st byte, the contents of the status register (SRD) with the 2nd byte and the contents of status register 1 (SRD1) with the 3rd byte are read.

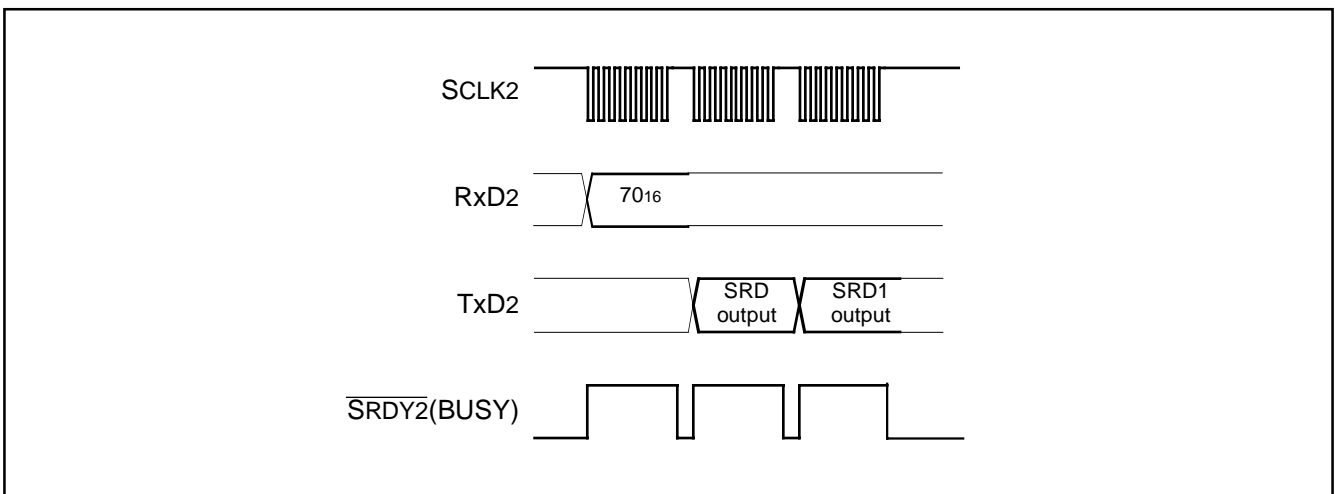

Fig. 71 Timing for reading status register

●Clear Status Register Command

This command clears the bits (SR3 to SR5) which are set when the status register operation ends in error. When the "5016" command code is sent with the 1st byte, the aforementioned bits are cleared. When the clear status register operation ends, the $\overline{\text{SRDY2}}$ (BUSY) signal changes from "H" to "L" level.

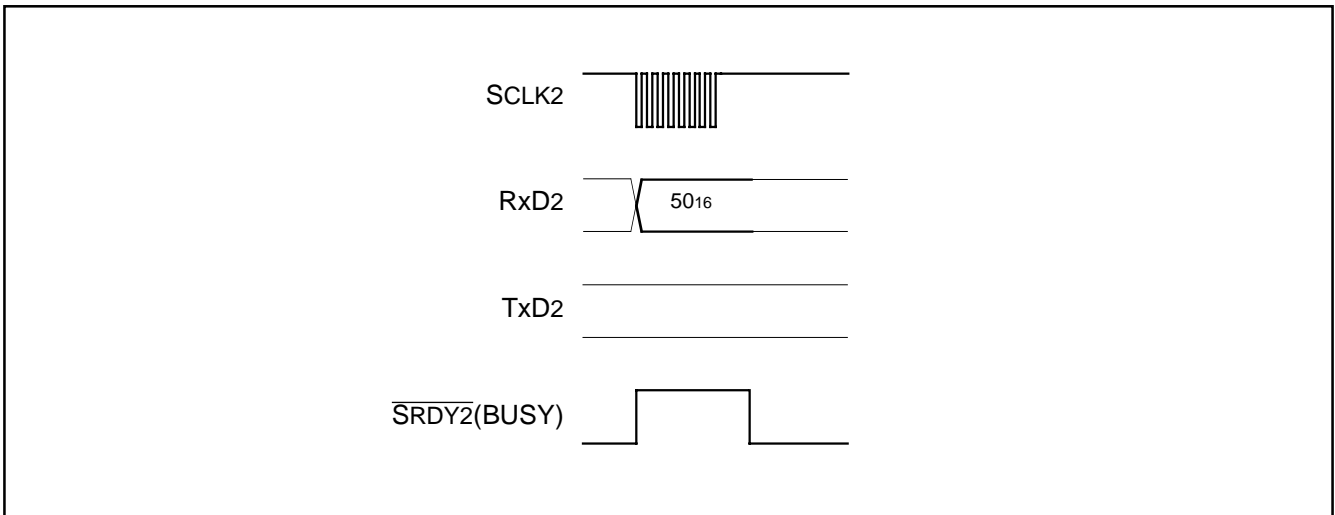

Fig. 72 Timing for clear status register

●Page Program Command

This command writes the specified page (256 bytes) in the flash memory sequentially one byte at a time. Execute the page program command as explained here following.

- (1) Transfer the "4116" command code with the 1st byte.
- (2) Transfer addresses A8 to A15 and A16 to A23 with the 2nd and 3rd bytes respectively.
- (3) From the 4th byte onward, as write data (D0 to D7) for the page (256 bytes) specified with addresses A8 to A23 is input sequentially from the smallest address first, that page is automatically written.

When reception setup for the next 256 bytes ends, the $\overline{\text{SRDY2}}$ (BUSY) signal changes from "H" to "L" level. The result of the page program can be known by reading the status register. For more information, see the section on the status register.

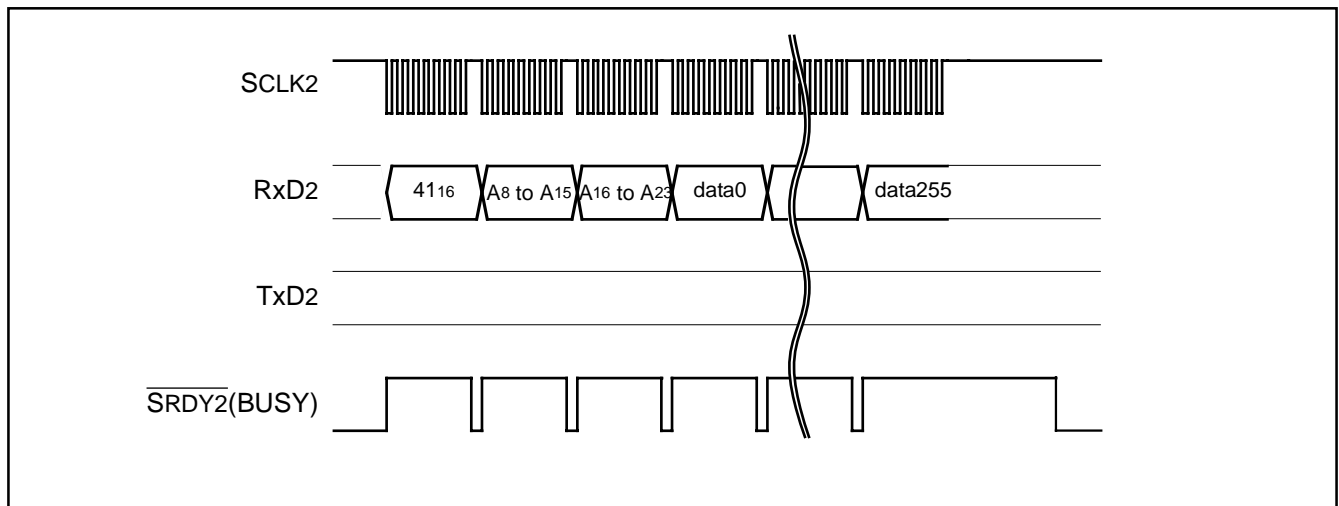

Fig. 73 Timing for page program

● **Block Erase Command**

This command erases the contents of specified block. Execute the block erase command as explained here following.

- (1) Transfer the "20₁₆" command code with the 1st byte.
- (2) Transfer addresses A₈ to A₁₅ with the 2nd bytes and addresses A₁₆ to A₂₃ with the 3rd bytes in serial.
- (3) Transfer the verify command code "D0₁₆" with the 4th byte.
 Then, the erase operation for the specified block of flash memory will start. Set the addresses A₈ to A₂₃ to the maximum address of the specified block.

When block erase ends, the $\overline{\text{SRDY2}}$ (BUSY) signal changes from "H" to "L" level. The result of the erase operation can be known by reading the status register. For details, refer to the status register.

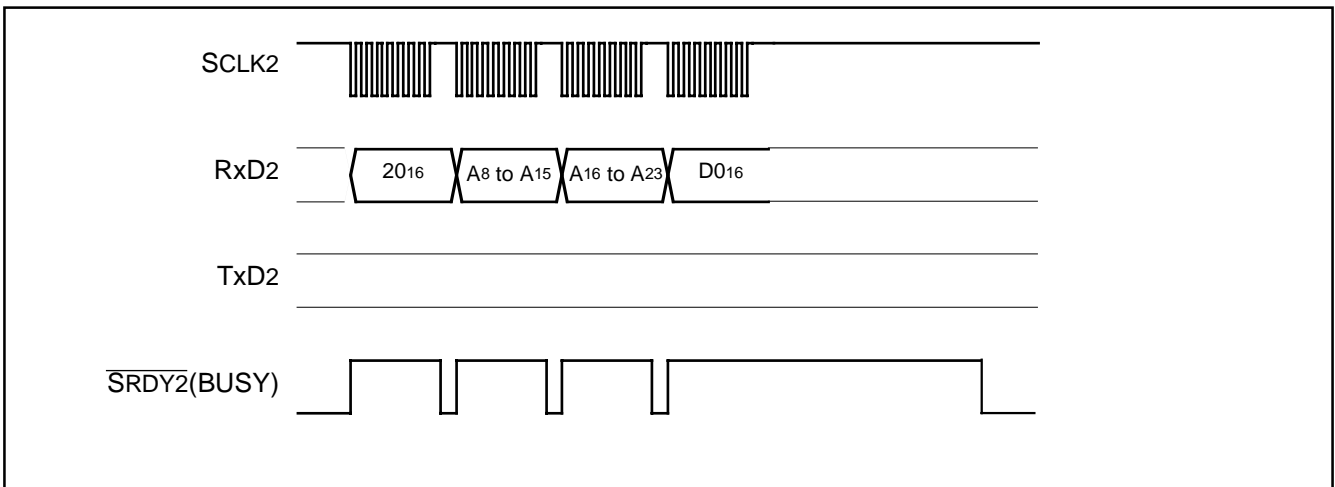

Fig. 74 Timing for block erase command

● **Erase All Blocks Command**

This command erases the contents of all blocks. Execute the erase all blocks command as explained here following.

- (1) Transfer the "A7₁₆" command code with the 1st byte.
- (2) Transfer the verify command code "D0₁₆" with the 2nd byte.
 With the verify command code, the erase operation will start and continue for all blocks in the flash memory.

When erase all blocks end, the $\overline{\text{SRDY2}}$ (BUSY) signal changes from "H" to "L" level. The result of the erase operation can be known by reading the status register.

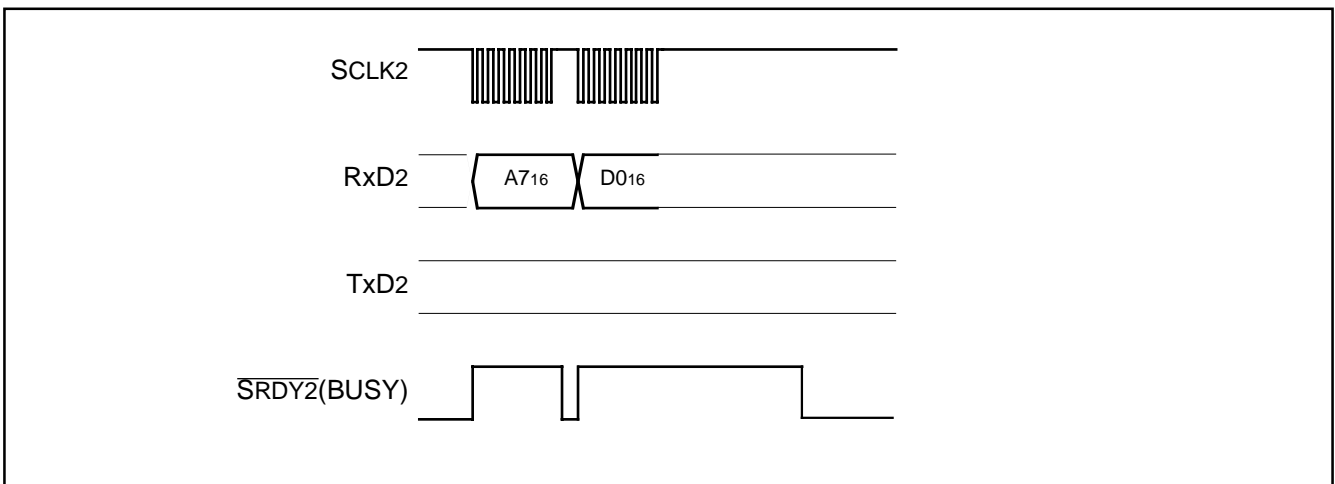

Fig. 75 Timing for erase all blocks

●Download Command

This command downloads a program to the RAM for execution. Execute the download command as explained here following.

- (1) Transfer the "FA16" command code with the 1st byte.
- (2) Transfer the program size with the 2nd and 3rd bytes.
- (3) Transfer the check sum with the 4th byte. The check sum is added to all data sent with the 5th byte onward.
- (4) The program to execute is sent with the 5th byte onward.

When all data has been transmitted, if the check sum matches, the downloaded program is executed. The size of the program will vary according to the internal RAM.

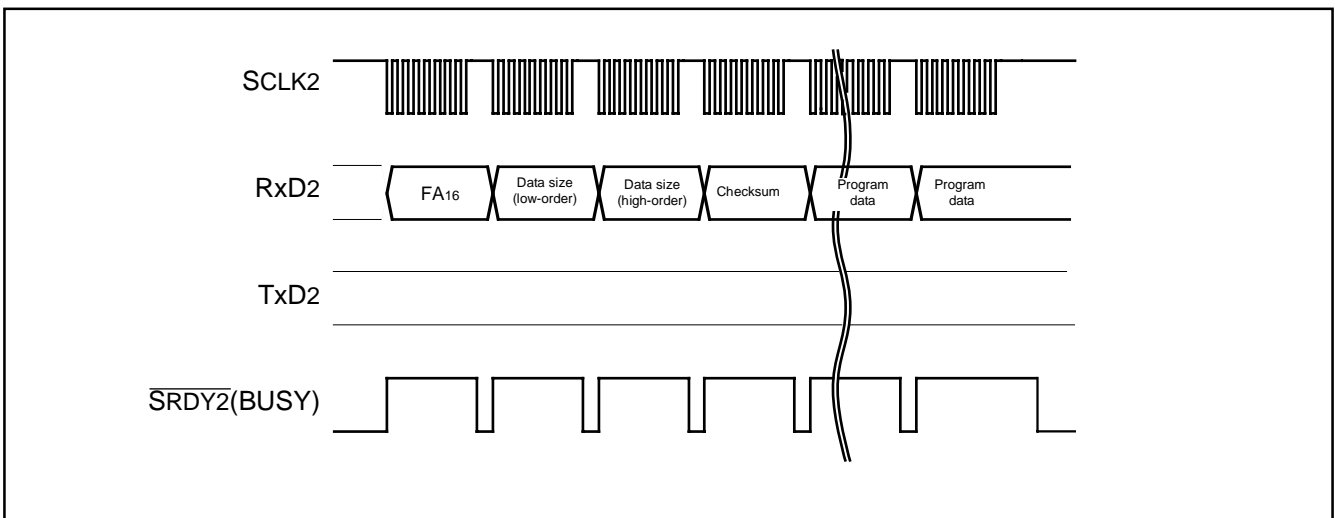

Fig. 76 Timing for download

●Version Data Output Command

This command outputs the version data of the control program stored in the Boot ROM area. Execute the version data output command as explained here following.

- (1) Transfer the "FB16" command code with the 1st byte.
- (2) The version data will be output from the 2nd byte onward. This data is composed of 8 ASCII code characters.

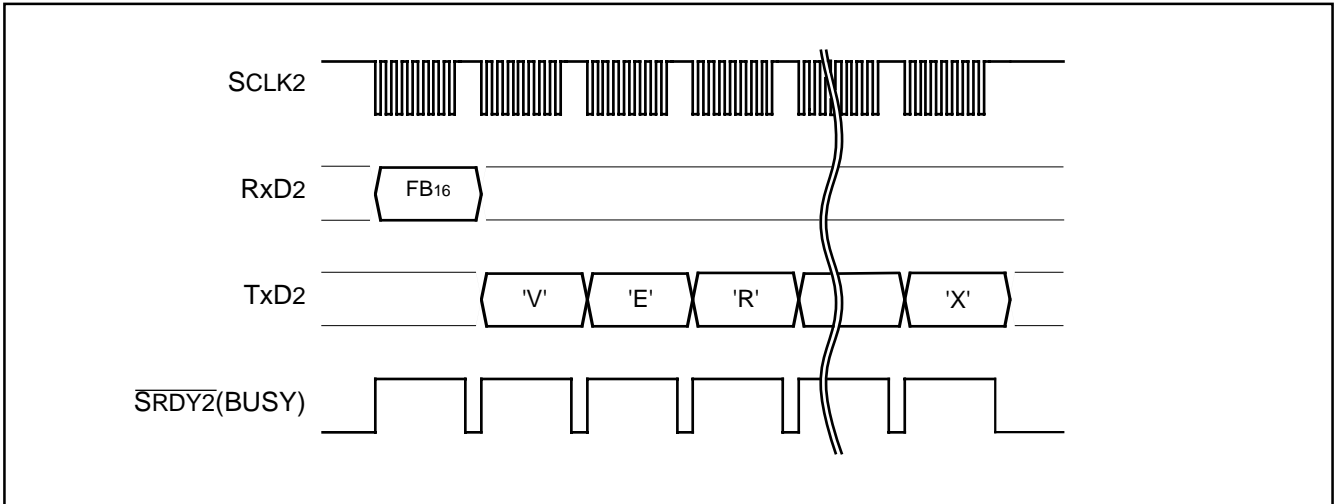

Fig. 77 Timing for version data output

●Boot ROM Area Output Command

This command reads the control program stored in the Boot ROM area in page (256 bytes) unit. Execute the Boot ROM area output command as explained here following.

- (1) Transfer the "FC16" command code with the 1st byte.
- (2) Transfer addresses A8 to A15 and A16 to A23 with the 2nd and 3rd bytes respectively.
- (3) From the 4th byte onward, data (D0 to D7) for the page (256 bytes) specified with addresses A8 to A23 will be output sequentially from the smallest address first synchronized with the fall of the clock.

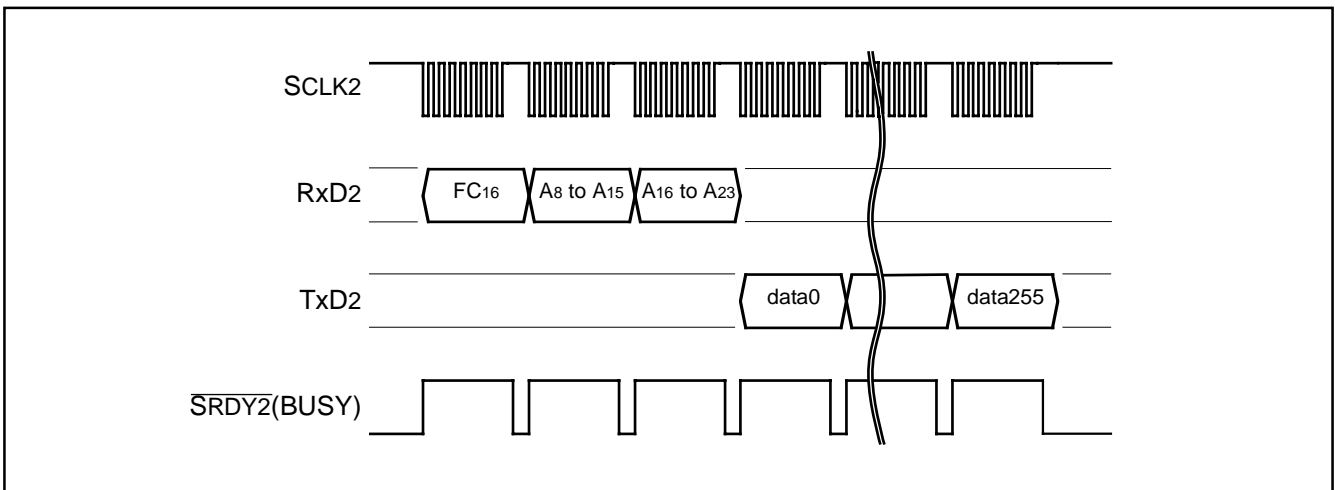

Fig. 78 Timing for Boot ROM area output

●ID Check

This command checks the ID code. Execute the boot ID check command as explained here following.

- (1) Transfer the "F5₁₆" command code with the 1st byte.
- (2) Transfer addresses A0 to A7, A8 to A15 and A16 to A23 of the 1st byte of the ID code with the 2nd, 3rd and 4th respectively.
- (3) Transfer the number of data sets of the ID code with the 5th byte.
- (4) Transfer the ID code with the 6th byte onward, starting with the 1st byte of the code.

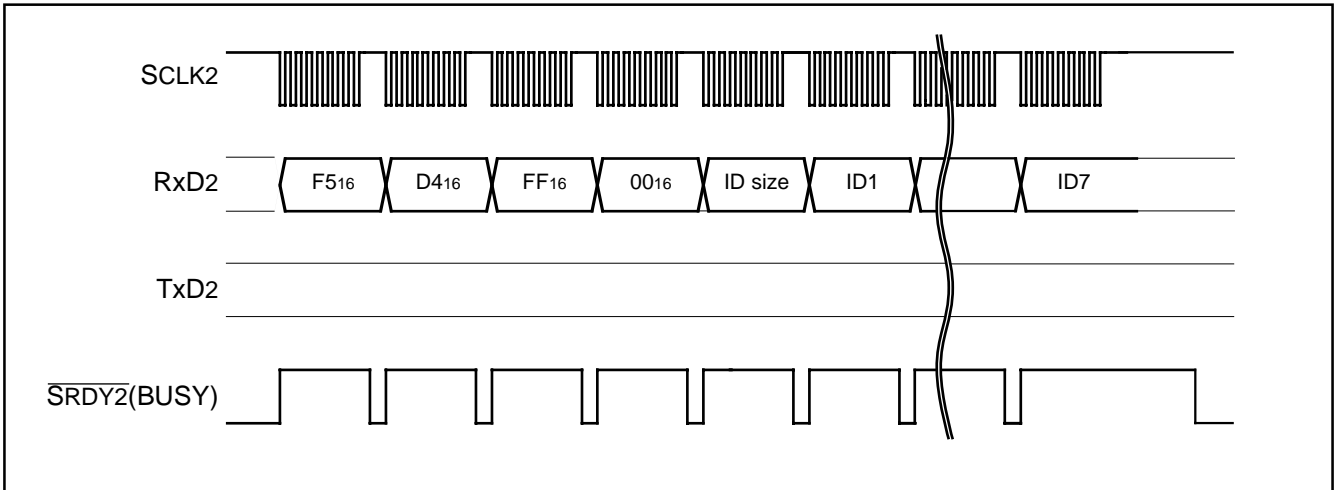

Fig. 79 Timing for ID check

●ID Code

When the flash memory is not blank, the ID code sent from the serial programmer and the ID code written in the flash memory are compared to see if they match. If the codes do not match, the command sent from the serial programmer is not accepted. An ID code contains 8 bits of data. Area is, from the 1st byte, addresses FFD4₁₆ to FFDA₁₆. Write a program into the flash memory, which already has the ID code set for these addresses.

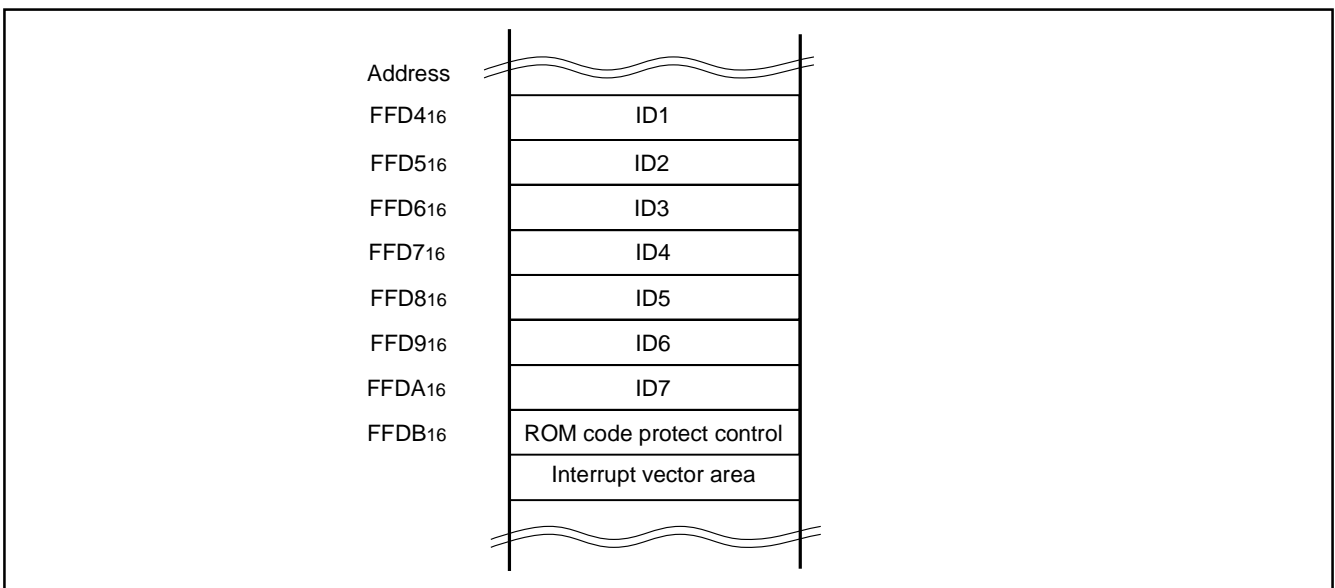

Fig. 80 ID code storage addresses

●**Status Register (SRD)**

The status register indicates operating status of the flash memory and status such as whether an erase operation or a program ended successfully or in error. It can be read by writing the read status register command (7016). Also, the status register is cleared by writing the clear status register command (5016).

Table 16 lists the definition of each status register bit. After releasing the reset, the status register becomes "8016".

•**Sequencer status (SR7)**

The sequencer status indicates the operating status of the flash memory.

After power-on and recover from deep power down mode, the sequencer status is set to "1" (ready).

This status bit is set to "0" (busy) during write or erase operation and is set to "1" upon completion of these operations.

•**Erase status (SR5)**

The erase status indicates the operating status of erase operation. If an erase error occurs, it is set to "1". When the erase status is cleared, it is set to "0".

•**Program status (SR4)**

The program status indicates the operating status of write operation. If a write error occurs, it is set to "1". When the program status is cleared, it is set to "0".

Table 16 Status register (SRD)

SRD bits	Status name	Definition	
		"1"	"0"
SR7 (bit7)	Sequencer status	Ready	Busy
SR6 (bit6)	Reserved	-	-
SR5 (bit5)	Erase status	Terminated in error	Terminated normally
SR4 (bit4)	Program status	Terminated in error	Terminated normally
SR3 (bit3)	Reserved	-	-
SR2 (bit2)	Reserved	-	-
SR1 (bit1)	Reserved	-	-
SR0 (bit0)	Reserved	-	-

●**Status Register 1 (SRD1)**

The status register 1 indicates the status of serial communications, results from ID checks and results from check sum comparisons. It can be read after the SRD by writing the read status register command (70₁₆). Also, status register 1 is cleared by writing the clear status register command (50₁₆).

Table 17 lists the definition of each status register 1 bit. At power-on, when user ROM area is blank, this register becomes "0C₁₆", and when writing to the area is completed, the register becomes "00₁₆", and the flag status is maintained even after the reset.

•**Boot update completed bit (SR15)**

This flag indicates whether the control program was downloaded to the RAM or not, using the download function.

•**Check sum consistency bit (SR12)**

This flag indicates whether the check sum matches or not when a program, is downloaded for execution using the download function.

•**ID check completed bits (SR11 and SR10)**

These flags indicate the result of ID checks. Some commands cannot be accepted without an ID check.

•**Data reception time out (SR9)**

This flag indicates when a time out error is generated during data reception. If this flag is attached during data reception, the received data is discarded and the MCU returns to the command wait state.

Table 17 Status register 1 (SRD1)

SRD1 bits	Status name	Definition	
		"1"	"0"
SR15 (bit7)	Boot update completed bit	Update completed	Not Update
SR14 (bit6)	Reserved	-	-
SR13 (bit5)	Reserved	-	-
SR12 (bit4)	Checksum match bit	Match	Mismatch
SR11 (bit3) SR10 (bit2)	ID check completed bits	00 01 10 11	Not verified Verification mismatch Reserved Verified
SR9 (bit1)	Data reception time out	Time out	Normal operation
SR8 (bit0)	Reserved	-	-

Full Status Check

Results from executed erase and program operations can be known by running a full status check. Figure 81 shows a flowchart of the full status check and explains how to remedy errors which occur.

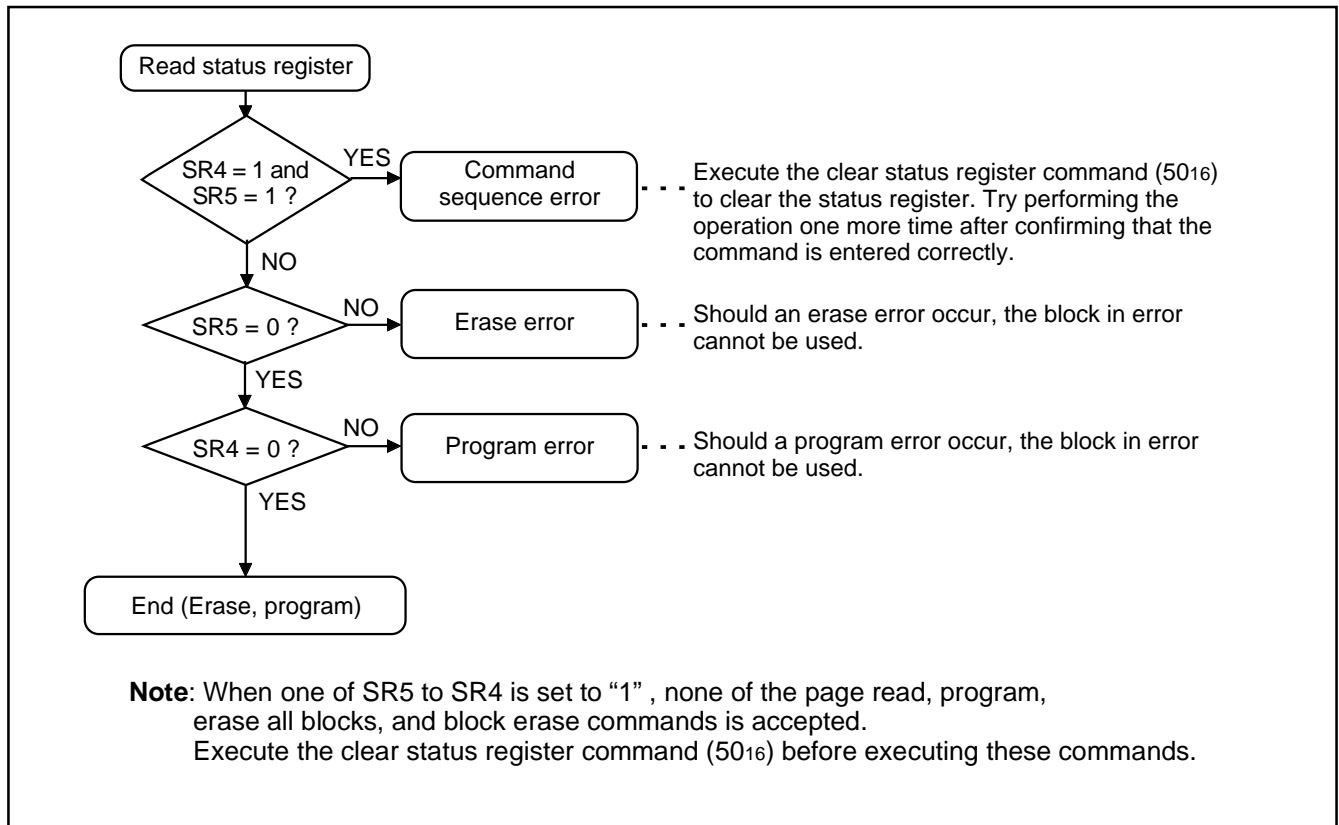

Fig. 81 Full status check flowchart and remedial procedure for errors

Example Circuit Application for Standard Serial I/O Mode

Figure 82 shows a circuit application for the standard serial I/O mode. Control pins will vary according to a programmer, therefore see a programmer manual for more information.

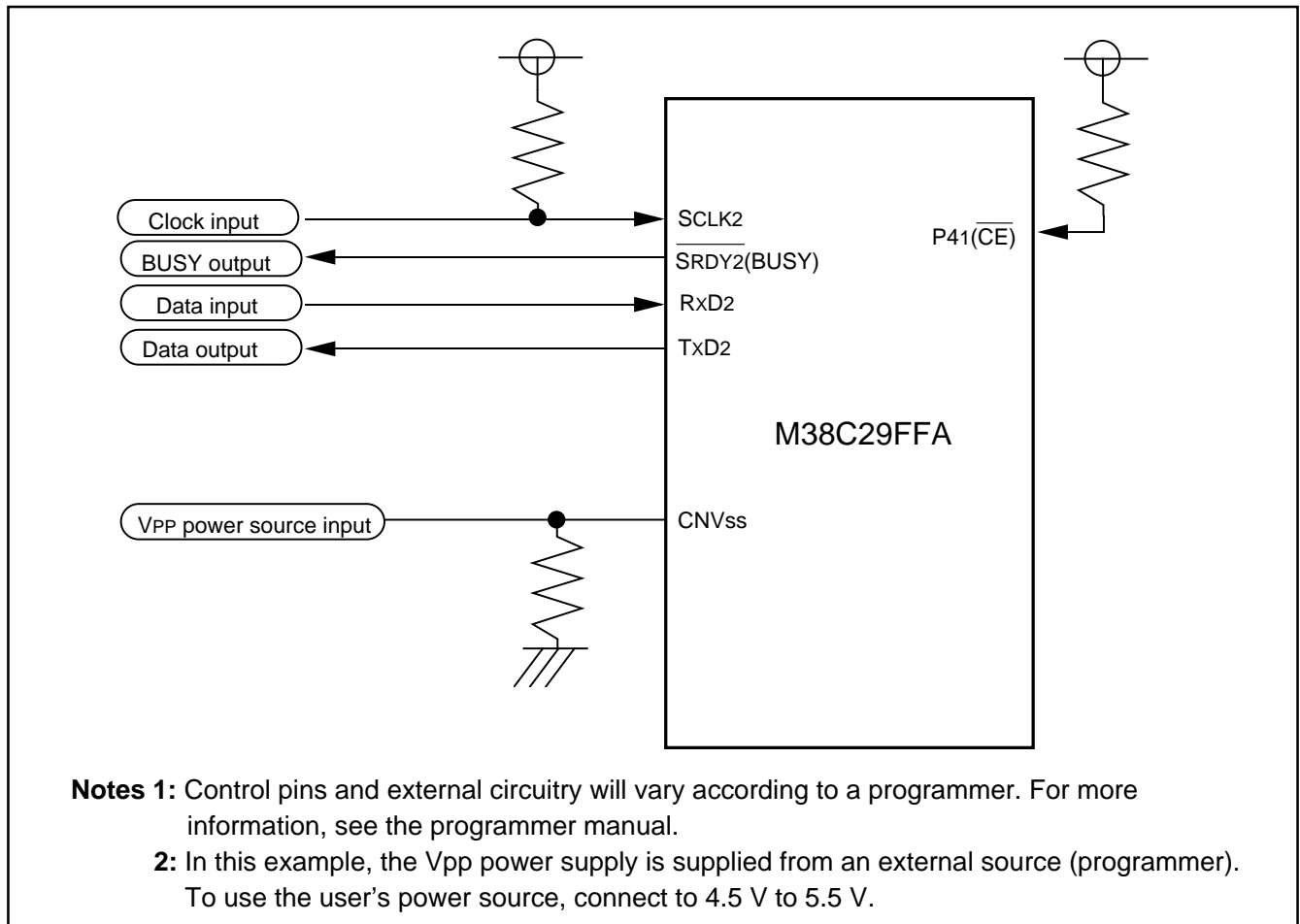

Fig. 82 Example circuit application for standard serial I/O mode

PRELIMINARY
Notice: This is not a final specification.
Some parametric limits are subject to change.

ELECTRICAL CHARACTERISTICS (Flash memory version)
Absolute Maximum Ratings

Table 18 Absolute maximum ratings (Flash memory version)

Symbol	Parameter	Conditions	Ratings	Unit
VCC	Power source voltage	All voltages are based on Vss. Output transistors are cut off.	-0.3 to 6.5	V
Vi	Input voltage P00-P07, P10-P17, P20-P27, P30-P37, P40-P47, P50-P57, P60-P62		-0.3 to VCC+0.3	V
Vi	Input voltage VL1		-0.3 to VL2	V
Vi	Input voltage VL2		VL1 to VL3	V
Vi	Input voltage VL3		VL2 to 6.5	V
Vi	Input voltage RESET, XIN		-0.3 to VCC+0.3	V
Vi	Input voltage CNVSS		-0.3 to 6.5	V
Vo	Output voltage P00-P07, P10-P17, P20-P27	At output port	-0.3 to VCC+0.3	V
		At segment output	-0.3 to VL3+0.3	V
Vo	Output voltage COM0-COM3		-0.3 to VL3+0.3	V
Vo	Output voltage P30-P37, P40-P47, P50-P57, P60-P62		-0.3 to VCC+0.3	V
Vo	Output voltage XOUT		-0.3 to VCC+0.3	V
Pd	Power dissipation	Ta = 25°C	300	mW
Topr	Operating temperature	At MCU operation	-20 to 85	°C
		At flash memory mode	25 ± 5	°C
Tstg	Storage temperature		-40 to 125	°C

Recommended Operating Conditions

Table 19 Recommended operating conditions (Flash memory version)

(VCC = 2.5 to 5.5 V, Ta = -20 to 85 °C, unless otherwise noted)

Symbol	Parameter		Limits			Unit
			Min.	Typ.	Max.	
VCC	Power source voltage (Note 1)	f(φ) = 5 MHz	4.5	5.0	5.5 (Note 3)	V
		f(φ) = 4 MHz	4.0	5.0	5.5 (Note 3)	V
		f(φ) = 2 MHz	2.5	5.0	5.5 (Note 3)	V
		Low-speed mode	2.5	5.0	5.5 (Note 3)	V
		Oscillation start voltage (Note 2)	0.15 X f + 1.3			V
VSS	Power source voltage		0		V	
VL3	Power source voltage for LCD		2.5	5.5	V	
VREF	A-D converter reference voltage		2.0	VCC	V	
AVSS	Analog power source voltage			0	V	
VIA	Analog input voltage AN0-AN7		AVSS	VCC	V	
VIH	"H" input voltage P04-P07, P10-P17, P20-P27, P30, P32, P35, P36, P40-P47, P52, P53, P62		0.7VCC	VCC	V	
VIH	"H" input voltage P00-P03, P31, P33, P34, P37, P50, P51, P54-P57, P60, P61		0.8VCC	VCC	V	
VIH	"H" input voltage RESET		0.8VCC	VCC	V	
VIH	"H" input voltage XIN		0.8VCC	VCC	V	
VIH	"H" input voltage XCIN (Note 4)		1.5	VCC	V	
VIL	"L" input voltage P04-P07, P10-P17, P20-P27, P30, P32, P35, P36, P40-P47, P52, P53, P62		0	0.3VCC	V	
VIL	"L" input voltage P00-P03, P31, P33, P34, P37, P50, P51, P54-P57, P60, P61, CNVSS		0	0.2VCC	V	
VIL	"L" input voltage RESET		0	0.2VCC	V	
VIL	"L" input voltage XIN		0	0.2VCC	V	
VIL	"L" input voltage XCIN (Note 5)		0	0.4	V	

Notes 1: When using the A-D converter, refer to "A-D Converter Characteristics".

2: The oscillation start voltage and the oscillation start time differ in accordance with an oscillator, a circuit constant, or temperature, etc. When power supply voltage is low and the high frequency oscillator is used, an oscillation start will require sufficient conditions.

f: This is an oscillator's oscillation frequency. For example, when oscillation frequency is 8 MHz, substitute "8".

3: It is the rating value when VCC = 5.0 to 5.5 V at program/erase. The value is (VCC at program/erase) + 0.5 V when VCC = 3.0 to 5.0 V at program/erase.

4: When the XCIN/P61 pin is not connected to an oscillator, refer to VIH for P61.

5: When the XCIN/P61 pin is not connected to an oscillator, refer to VIL for P61.

Table 20 Recommended operating conditions (Flash memory version)

(V_{CC} = 2.5 to 5.5 V, T_a = -20 to 85 °C, unless otherwise noted)

Symbol	Parameter	Limits			Unit
		Min.	Typ.	Max.	
ΣIOH(peak)	"H" total peak output current (Note 1) P00-P07, P10-P17, P20-P27, P30-P37			-20	mA
ΣIOH(peak)	"H" total peak output current (Note 1) P40-P47, P50-P57, P60-P62			-20	mA
ΣIOL(peak)	"L" total peak output current (Note 1) P00-P07, P10-P17, P20-P27			20	mA
ΣIOL(peak)	"L" total peak output current (Note 1) P40-P47, P50, P51, P54-P57, P60-P62			20	mA
ΣIOL(peak)	"L" total peak output current (Note 1) P30-P37, P52, P53			110	mA
ΣIOH(avg)	"H" total average output current (Note 1) P00-P07, P10-P17, P20-P27, P30-P37			-10	mA
ΣIOH(avg)	"H" total average output current (Note 1) P40-P47, P50-P57, P60-P62			-10	mA
ΣIOL(avg)	"L" total average output current (Note 1) P00-P07, P10-P17, P20-P27			10	mA
ΣIOL(avg)	"L" total average output current (Note 1) P40-P47, P50, P51, P54-P57, P60-P62			10	mA
ΣIOL(avg)	"L" total average output current (Note 1) P30-P37, P52, P53			90	mA
IOH(peak)	"H" peak output current (Note 2) P00-P07, P10-P17, P20-P27			-1.0	mA
IOH(peak)	"H" peak output current (Note 2) P30-P37, P40-P47, P50-P57, P60-P62			-5.0	mA
IOL(peak)	"L" peak output current (Note 2) P00-P07, P10-P17, P20-P27			10	mA
IOL(peak)	"L" peak output current (Note 2) P40-P47, P50, P51, P54-P57, P60-P62			10	mA
IOL(peak)	"L" peak output current (Note 2) P30-P37, P52, P53			30	mA
IOH(avg)	"H" average output current (Note 3) P00-P07, P10-P17, P20-P27			-0.5	mA
IOH(avg)	"H" average output current (Note 3) P30-P37, P40-P47, P50-P57, P60-P62			-2.5	mA
IOL(avg)	"L" average output current (Note 3) P00-P07, P10-P17, P20-P27			5.0	mA
IOL(avg)	"L" average output current (Note 3) P40-P47, P50, P51, P54-P57, P60-P62			5.0	mA
IOL(avg)	"L" average output current (Note 3) P30-P37, P52, P53			15	mA

Notes 1: The total output current is the sum of all the currents flowing through all the applicable ports. The total average current is an average value measured over 100 ms. The total peak current is the peak value of all the currents.

2: The peak output current is the peak current flowing in each port.

3: The average output current is average value measured over 100 ms.

Table 21 Recommended operating conditions (Flash memory version)

($V_{CC} = 2.5$ to 5.5 V, $T_a = -20$ to 85 °C, unless otherwise noted)

Symbol	Parameter	Test conditions	Limits			Unit
			Min.	Typ.	Max.	
f(CNTR0)	Timer X and Timer Y	($4.5 \text{ V} \leq V_{CC} \leq 5.5 \text{ V}$)			5.0	MHz
f(CNTR1)	Input frequency (duty cycle 50%)	($4.0 \text{ V} \leq V_{CC} < 4.5 \text{ V}$)			$2 \times V_{CC} - 4$	MHz
		($V_{CC} < 4.0 \text{ V}$)			V_{CC}	MHz
f(Tclk)	Timer X, Timer Y, Timer 1, Timer 2, Timer 3 and Timer 4 Clock input frequency (Count source frequency of each timer)	($4.5 \text{ V} \leq V_{CC} \leq 5.5 \text{ V}$)			10.0	MHz
		($4.0 \text{ V} \leq V_{CC} < 4.5 \text{ V}$)			$4 \times V_{CC} - 8$	MHz
		($V_{CC} < 4.0 \text{ V}$)			$2 \times V_{CC}$	MHz
f(ϕ)	System clock ϕ frequency	($4.5 \text{ V} \leq V_{CC} \leq 5.5 \text{ V}$)			5.0	MHz
		($4.0 \text{ V} \leq V_{CC} < 4.5 \text{ V}$)			$2 \times V_{CC} - 4$	MHz
		($V_{CC} < 4.0 \text{ V}$)			V_{CC}	MHz
f(XIN)	Main clock input oscillation frequency (Notes 1, 3)	($4.5 \text{ V} \leq V_{CC} \leq 5.5 \text{ V}$)	1.0		10.0	MHz
		($2.5 \text{ V} \leq V_{CC} < 4.5 \text{ V}$)	1.0		8.0	MHz
f(XCIN)	Sub-clock input oscillation frequency (Notes 1, 2, 3)			32.768	50	kHz

Notes 1: When the oscillation frequency has a duty cycle of 50%.

2: When using the microcomputer in low-speed mode, set the clock input oscillation frequency on condition that $f(XCIN) < f(XIN)/3$.

3: The oscillation start voltage and the oscillation start time differ in accordance with an oscillator, a circuit constant, or temperature, etc. When power supply voltage is low and the high frequency oscillator is used, an oscillation start will require sufficient conditions.

Electrical Characteristics

Table 22 Electrical characteristics (Flash memory version)

(V_{CC} = 4.0 to 5.5 V, T_a = -20 to 85 °C, unless otherwise noted)

Symbol	Parameter	Test conditions	Limits			Unit
			Min.	Typ.	Max.	
VOH	“H” output voltage P00–P07, P10–P17, P20–P27	IOH = -1 mA	V _{CC} -2.0			V
		IOH = -0.25 mA	V _{CC} -0.8			V
		V _{CC} = 2.5 V				
VOH	“H” output voltage P30–P37, P40–P47, P50–P57, P60–P62	IOH = -5 mA	V _{CC} -2.0			V
		IOH = -1.5 mA	V _{CC} -0.5			V
		IOH = -1.25 mA	V _{CC} -0.8			V
VOL	“L” output voltage P00–P07, P10–P17, P20–P27, P40–P47, P50, P51, P54–P57, P60–P62	IOL = 10 mA			2.0	V
		IOL = 3 mA			0.5	V
		IOL = 2.5 mA			0.8	V
		V _{CC} = 2.5 V				
VOL	“L” output voltage P30–P37, P52, P53	IOL = 15 mA			2.0	V
		IOL = 4 mA			0.8	V
		V _{CC} = 2.5 V				
VT+–VT-	Hysteresis INT0–INT2, CNTR0, CNTR1, P00–P03, P54–P57			0.5		V
VT+–VT-	Hysteresis SCLK1, SCLK2, RxD1, RxD2			0.5		V
VT+–VT-	Hysteresis $\overline{\text{RESET}}$			0.5		V
I _{IH}	“H” input current P00–P07, P10–P17, P20–P27, P30–P37, P40–P47, P50–P57, P60–P62	V _I = V _{CC}			5.0	μA
I _{IH}	“H” input current $\overline{\text{RESET}}$	V _I = V _{CC}			5.0	μA
I _{IH}	“H” input current X _{IN}	V _I = V _{CC}		4.0		μA
I _{IL}	“L” input current P00–P07, P10–P17, P20–P27, P30–P37, P40–P47, P50–P57, P60–P62	V _I = V _{SS} Pull-up “OFF”			-5.0	μA
		V _{CC} = 5.0 V, V _I = V _{SS} Pull-up “ON”	-60	-120	-240	μA
		V _{CC} = 3.0 V, V _I = V _{SS} Pull-up “ON”	-25	-40	-100	μA
I _{IL}	“L” input current $\overline{\text{RESET}}$	V _I = V _{SS}			-5.0	μA
I _{IL}	“L” input current X _{IN}	V _I = V _{SS}		-4.0		μA

Table 23 Electrical characteristics (Flash memory version)

(V_{CC} = 2.5 to 5.5 V, T_a = -20 to 85 °C, unless otherwise noted)

Symbol	Parameter	Test conditions	Limits			Unit
			Min.	Typ.	Max.	
VRAM	RAM hold voltage	When clock is stopped	1.8		5.5	V
ICC	Power source current	Frequency/2 mode, V _{CC} = 5 V f(XIN) = 10 MHz f(XCIN) = 32.768 kHz Output transistors "OFF", A-D converter in operating		6.0	8.6	mA
		Frequency/2 mode, V _{CC} = 5 V f(XIN) = 8 MHz f(XCIN) = 32.768 kHz Output transistors "OFF", A-D converter in operating		5.0	7.2	mA
		Frequency/2 mode, V _{CC} = 5 V f(XIN) = 8 MHz (in WIT state) f(XCIN) = 32.768 kHz Output transistors "OFF", A-D converter stopped		1.0	2.0	mA
		Low-speed mode, V _{CC} = 5 V, T _a ≤ 55 °C f(XIN) = stopped f(XCIN) = 32.768 kHz Output transistors "OFF"		150	200	μA
		Low-speed mode, V _{CC} = 5 V, T _a = 25 °C f(XIN) = stopped f(XCIN) = 32.768 kHz (in WIT state) Output transistors "OFF"		6	10	μA
		Low-speed mode, V _{CC} = 3 V, T _a ≤ 55 °C f(XIN) = stopped f(XCIN) = 32.768 kHz Output transistors "OFF"		125	165	μA
		Low-speed mode, V _{CC} = 3 V, T _a = 25 °C f(XIN) = stopped f(XCIN) = 32.768 kHz (in WIT state) Output transistors "OFF"		4	8	μA
		All oscillation stopped (in STP state) Output transistors "OFF"	T _a = 25 °C		0.1	1.0
	T _a = 85 °C			10	μA	

Table 24 Direct-electrical characteristics (Flash memory version)

(V_{CC} = 4.5 to 5.5 V, T_a = 25 °C, unless otherwise noted)

Symbol	Parameter	Test conditions	Limits			Unit
			Min.	Typ.	Max.	
I _{PP1}	V _{PP} Power source current (at read)	V _{PP} = V _{CC} , at flash memory mode			100	μA
I _{PP2}	V _{PP} Power source current (at programming)				60	mA
I _{PP3}	V _{PP} Power source current (at erase)				30	mA
V _{PP}	V _{PP} Power source voltage	At flash memory mode	4.5		5.5	V

A-D Converter Characteristics

Table 25 A-D converter characteristics (Flash memory version)

(V_{CC} = 2.5 to 5.5 V, V_{SS} = AV_{SS} = 0 V, T_a = -20 to 85 °C, Port state = stopped, unless otherwise noted)

Symbol	Parameter	Test conditions	Limits			Unit
			Min.	Typ.	Max.	
—	Resolution				10	Bits
—	Absolute accuracy (quantification error excluded)	V _{CC} = V _{REF} = 5 V AD clock frequency = 5 MHz 10bitAD mode			±6	LSB
		V _{CC} = V _{REF} = 4 V AD clock frequency = 4 MHz 10bitAD mode				
		V _{CC} = V _{REF} = 2.5 V AD clock frequency = 500 kHz 10bitAD mode, booster effective			±5	
		V _{CC} = V _{REF} = 5 V AD clock frequency = 4 MHz 8bitAD mode			±2	
		V _{CC} = V _{REF} = 2.5 V AD clock frequency = 1 MHz				
T _{conv}	Conversion time	8bitAD mode, booster effective AD conversion clock selection bit :XIN/2,			t _c (XIN)X121 (Note)	μs
RLADDER	Ladder resistor	10bitAD mode	12	35	100	kΩ
IVREF	Reference input current		50	150	200	μA
I _A	Analog input current	V _{REF} = 5 V			5.0	μA

Note: When "Frequency/4, 8 or 16" is selected by the AD conversion clock selection bit, the above conversion time is multiplied by 2, 4 or 8.

LCD Power Supply Characteristics

Table 26 LCD power supply characteristics (when connecting division resistors for LCD power supply) (Flash memory version)

(V_{CC} = 2.5 to 5.5 V, T_a = -20 to 85 °C, unless otherwise noted)

Symbol	Parameter	Test conditions	Limits			Unit		
			Min.	Typ.	Max.			
RLCD	Division resistor for LCD power supply (Note)	RSEL = "10"		200		kΩ		
		RSEL = "11"		5				
		LCD drive timing A	LCD circuit division ratio = divided by 1	RSEL = "01"			120	
				RSEL = "00"			90	
			LCD circuit division ratio = divided by 2	RSEL = "01"			150	
				RSEL = "00"			120	
			LCD circuit division ratio = divided by 4	RSEL = "01"			170	
				RSEL = "00"			150	
			LCD circuit division ratio = divided by 8	RSEL = "01"			190	
				RSEL = "00"			170	
		LCD drive timing B	LCD circuit division ratio = divided by 1	RSEL = "01"			150	
				RSEL = "00"			120	
			LCD circuit division ratio = divided by 2	RSEL = "01"			170	
				RSEL = "00"			150	
			LCD circuit division ratio = divided by 4	RSEL = "01"			190	
				RSEL = "00"			170	
LCD circuit division ratio = divided by 8	RSEL = "01"			190				
	RSEL = "00"			190				

Note: The value is the average of each one division resistor.

Timing Requirements And Switching Characteristics

Table 27 Timing requirements 1 (Flash memory version)

(V_{CC} = 4.0 to 5.5 V, V_{SS} = 0 V, T_a = -20 to 85 °C, unless otherwise noted)

Symbol	Parameter	Limits			Unit	
		Min.	Typ.	Max.		
tw(RESET)	Reset input "L" pulse width	2			μs	
tc(XIN)	Main clock input cycle time (XIN input)	(4.5 V ≤ V _{CC} ≤ 5.5 V)	100		1000	ns
		(4.0 V ≤ V _{CC} < 4.5 V)	1000(4 × V _{CC} - 8)		1000	ns
twH(XIN)	Main clock input "H" pulse width	(4.5 V ≤ V _{CC} ≤ 5.5 V)	40		500	ns
		(4.0 V ≤ V _{CC} < 4.5 V)	45		500	ns
twL(XIN)	Main clock input "L" pulse width	(4.5 V ≤ V _{CC} ≤ 5.5 V)	40		500	ns
		(4.0 V ≤ V _{CC} < 4.5 V)	45		500	ns
tc(XCIN)	Sub clock input cycle time	20			μs	
twH(XCIN)	Sub clock input "H" pulse width	9			μs	
twL(XCIN)	Sub clock input "L" pulse width	9			μs	
tc(CNTR)	CNTR0, CNTR1 input cycle time	(4.5 V ≤ V _{CC} ≤ 5.5 V)	200			ns
		(4.0 V ≤ V _{CC} < 4.5 V)	1000(2 × V _{CC} - 4)			ns
twH(CNTR)	CNTR0, CNTR1 input "H" pulse width	(4.5 V ≤ V _{CC} ≤ 5.5 V)	85			ns
		(4.0 V ≤ V _{CC} < 4.5 V)	105			ns
twL(CNTR)	CNTR0, CNTR1 input "L" pulse width	(4.5 V ≤ V _{CC} ≤ 5.5 V)	85			ns
		(4.0 V ≤ V _{CC} < 4.5 V)	105			ns
twH(INT)	INT0-INT2 input "H" pulse width	80			ns	
twL(INT)	INT0-INT2 input "L" pulse width	80			ns	
tc(SCLK)	Serial I/O1, 2 clock input cycle time (Note)	800			ns	
twH(SCLK)	Serial I/O1, 2 clock input "H" pulse width (Note)	370			ns	
twL(SCLK)	Serial I/O1, 2 clock input "L" pulse width (Note)	370			ns	
tsu(RxD-SCLK)	Serial I/O1, 2 input setup time	220			ns	
th(SCLK-RxD)	Serial I/O1, 2 input hold time	100			ns	

Note : When bit 6 of address 0FE016 or 0FE316 is "1" (clock synchronous).
 Divide this value by four when bit 6 of address 0FE016 or 0FE316 is "0" (UART).

Table 28 Timing requirements 2 (Flash memory version)

(V_{CC} = 2.5 to 4.0 V, V_{SS} = 0 V, T_a = -20 to 85 °C, unless otherwise noted)

Symbol	Parameter	Limits			Unit
		Min.	Typ.	Max.	
tw(RESET)	Reset input "L" pulse width	2			μs
tc(XIN)	Main clock input cycle time (XIN input)	125		1000	ns
twH(XIN)	Main clock input "H" pulse width	50		500	ns
twL(XIN)	Main clock input "L" pulse width	50		500	ns
tc(XCIN)	Sub clock input cycle time	20			μs
twH(XCIN)	Sub clock input "H" pulse width	9			μs
twL(XCIN)	Sub clock input "L" pulse width	9			μs
tc(CNTR)	CNTR0, CNTR1 input cycle time	750/(V _{CC} -1)			ns
twH(CNTR)	CNTR0, CNTR1 input "H" pulse width	tc(CNTR)/2-20			ns
twL(CNTR)	CNTR0, CNTR1 input "L" pulse width	tc(CNTR)/2-20			ns
twH(INT)	INT0-INT2 input "H" pulse width	230			ns
twL(INT)	INT0-INT2 input "L" pulse width	230			ns
tc(SCLK)	Serial I/O1, 2 clock input cycle time (Note)	2000			ns
twH(SCLK)	Serial I/O1, 2 clock input "H" pulse width (Note)	950			ns
twL(SCLK)	Serial I/O1, 2 clock input "L" pulse width (Note)	950			ns
tsu(RxD-SCLK)	Serial I/O1, 2 input setup time	400			ns
th(SCLK-RxD)	Serial I/O1, 2 input hold time	200			ns

Note : When bit 6 of address 0FE016 or 0FE316 is "1" (clock synchronous).
 Divide this value by four when bit 6 of address 0FE016 or 0FE316 is "0" (UART).

Table 29 Switching characteristics 1 (Flash memory version)

(Vcc = 4.0 to 5.5 V, Vss = 0 V, Ta = -20 to 85 °C, unless otherwise noted)

Symbol	Parameter	Limits			Unit
		Min.	Typ.	Max.	
twH(SCLK)	Serial I/O1, 2 clock output "H" pulse width	tc(SCLK)/2-30			ns
twL(SCLK)	Serial I/O1, 2 clock output "L" pulse width	tc(SCLK)/2-30			ns
td(SCLK-TxD)	Serial I/O1, 2 output delay time (Note 1)			140	ns
tV(SCLK-TxD)	Serial I/O1, 2 output valid time (Note 1)	-30			ns
tr(SCLK)	Serial I/O1, 2 clock output rising time			30	ns
tf(SCLK)	Serial I/O1, 2 clock output falling time			30	ns
tr(CMOS)	CMOS output rising time	P00-P07, P10-P17, P20-P27 (Note 2)	25	40	ns
		P30-P37, P40-P47, P50-P57, P60-P62 (Note 2)	15	30	ns
tf(CMOS)	CMOS output falling time	P00-P07, P10-P17, P20-P27 (Note 2)	15	30	ns
		P30-P37, P40-P47, P50-P57, P60-P62 (Note 2)			

Notes 1: When the P-channel output disable bit (bit 4 of address 0FE116 or 0FE416) is "0."

2: The XOUT, XCOUNT pins are excluded.

Table 30 Switching characteristics 2 (Flash memory version)

(Vcc = 2.5 to 4.0 V, Vss = 0 V, Ta = -20 to 85 °C, unless otherwise noted)

Symbol	Parameter	Limits			Unit
		Min.	Typ.	Max.	
twH(SCLK)	Serial I/O1, 2 clock output "H" pulse width	tc(SCLK)/2-80			ns
twL(SCLK)	Serial I/O1, 2 clock output "L" pulse width	tc(SCLK)/2-80			ns
td(SCLK-TxD)	Serial I/O1, 2 output delay time (Note 1)			400	ns
tV(SCLK-TxD)	Serial I/O1, 2 output valid time (Note 1)	-30			ns
tr(SCLK)	Serial I/O1, 2 clock output rising time			80	ns
tf(SCLK)	Serial I/O1, 2 clock output falling time			80	ns
tr(CMOS)	CMOS output rising time	P00-P07, P10-P17, P20-P27 (Note 2)	60	120	ns
		P30-P37, P40-P47, P50-P57, P60-P62 (Note 2)	40	80	ns
tf(CMOS)	CMOS output falling time	P00-P07, P10-P17, P20-P27 (Note 2)	40	80	ns
		P30-P37, P40-P47, P50-P57, P60-P62 (Note 2)			

Notes 1: When the P-channel output disable bit (bit 4 of address 0FE116 or 0FE416) is "0."

2: The XOUT, XCOUNT pins are excluded.

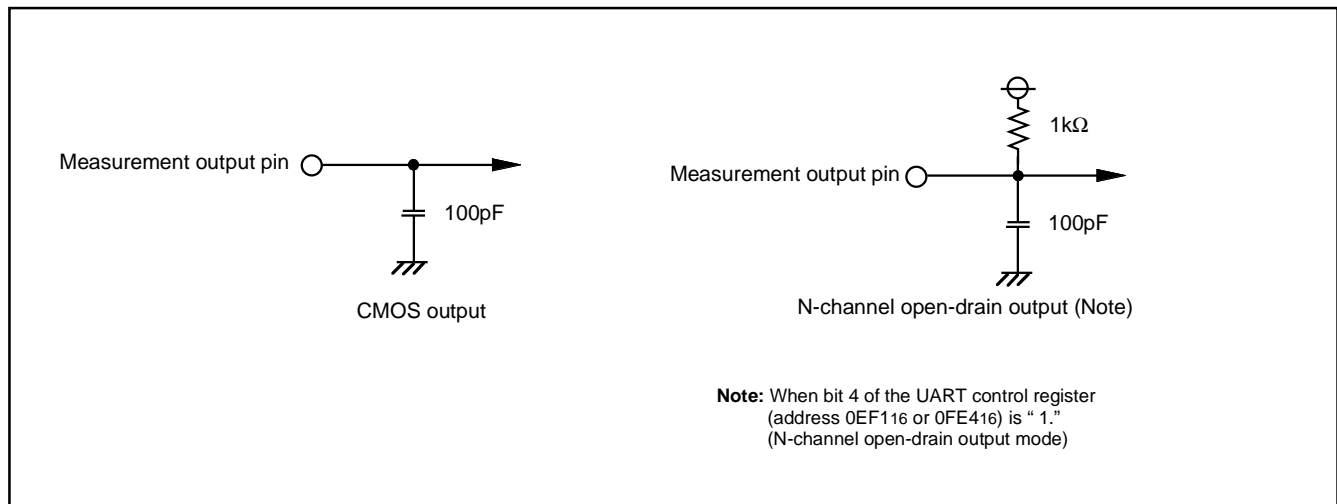

Fig. 83 Circuit for measuring output switching characteristics

PRELIMINARY
 Notice: This is not a final specification.
 Some parametric limits are subject to change.

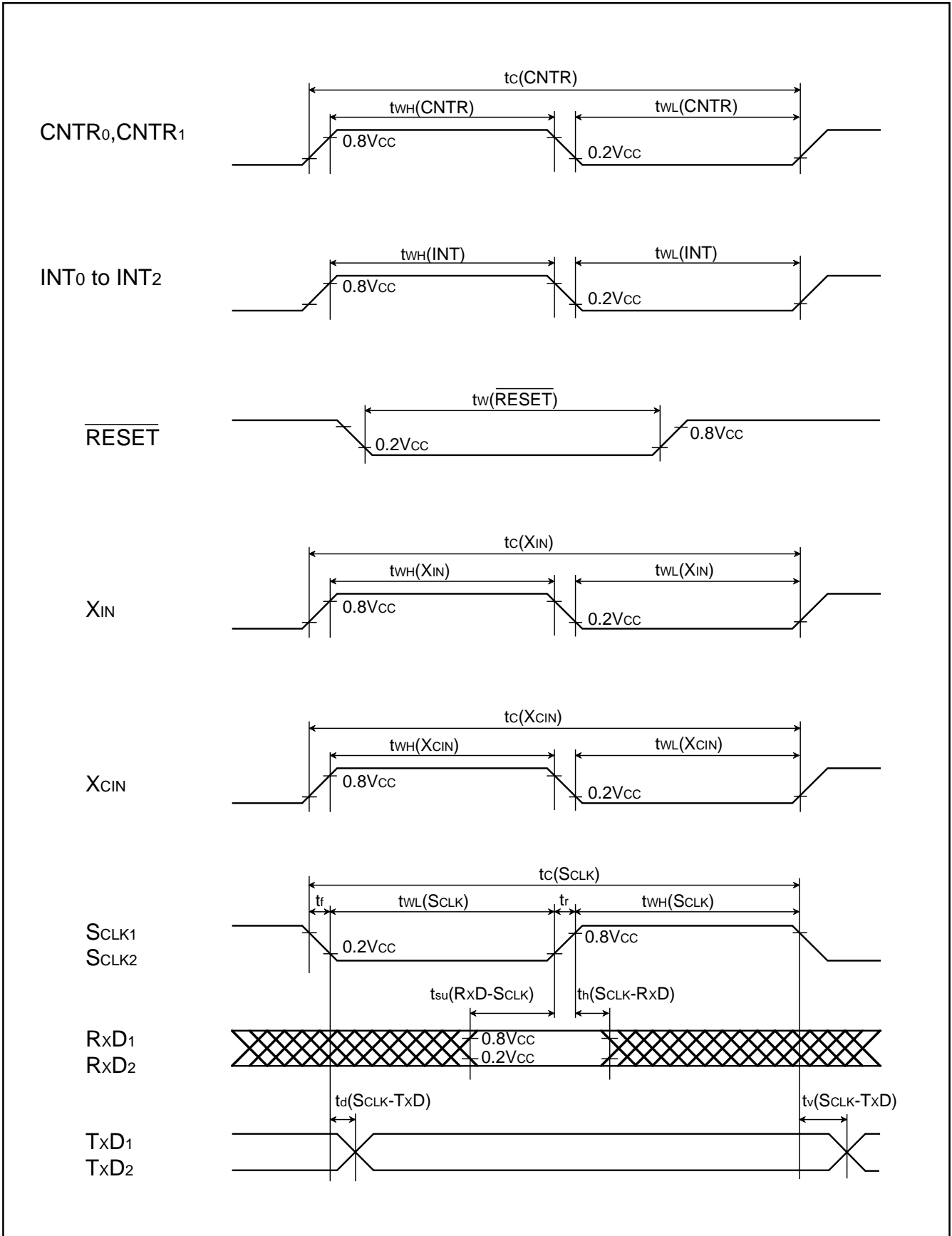

Fig. 84 Timing chart

PRELIMINARY
 Notice: This is not a final specification.
 Some parametric limits are subject to change.

ELECTRICAL CHARACTERISTICS

Absolute Maximum Ratings

Table 31 Absolute maximum ratings (Mask ROM version)

Symbol	Parameter	Conditions	Ratings	Unit
VCC	Power source voltage	All voltages are based on Vss. Output transistors are cut off.	-0.3 to 6.5	V
Vi	Input voltage P00-P07, P10-P17, P20-P27, P30-P37, P40-P47, P50-P57, P60-P62		-0.3 to VCC+0.3	V
Vi	Input voltage VL1		-0.3 to VL2	V
Vi	Input voltage VL2		VL1 to VL3	V
Vi	Input voltage VL3		VL2 to 6.5	V
Vi	Input voltage RESET, XIN, CNVss		-0.3 to VCC+0.3	V
Vo	Output voltage P00-P07, P10-P17, P20-P27		At output port	-0.3 to VCC+0.3
		At segment output	-0.3 to VL3+0.3	V
Vo	Output voltage COM0-COM3		-0.3 to VL3+0.3	V
Vo	Output voltage P30-P37, P40-P47, P50-P57, P60-P62		-0.3 to VCC+0.3	V
Vo	Output voltage XOUT		-0.3 to VCC+0.3	V
Pd	Power dissipation	Ta = 25°C	300	mW
Topr	Operating temperature		-20 to 85	°C
Tstg	Storage temperature		-40 to 125	°C

Recommended Operating Conditions

Table 32 Recommended operating conditions (Mask ROM version)

(Vcc = 1.8 to 5.5 V, Ta = -20 to 85°C, unless otherwise noted)

Symbol	Parameter		Limits			Unit	
			Min.	Typ.	Max.		
Vcc	Power source voltage (Note 1)	f(φ) = 5 MHz	4.5	5.0	5.5	V	
		f(φ) = 4 MHz	4.0	5.0	5.5	V	
		f(φ) = 2 MHz	2.0	5.0	5.5	V	
		f(φ) = 1 MHz	1.8	5.0	5.5	V	
		Low-speed mode	1.8	5.0	5.5	V	
		Oscillation start voltage (Note 2)	0.15 X f + 1.3			V	
Vss	Power source voltage			0		V	
VL3	Power source voltage for LCD		2.5		5.5	V	
VREF	A-D converter reference voltage		2.0		Vcc	V	
AVSS	Analog power source voltage			0		V	
VIA	Analog input voltage AN0-AN7		AVSS		Vcc	V	
VIH	"H" input voltage	P04-P07, P10-P17, P20-P27, P30, P32, P35, P36, P40-P47, P52, P53, P62	0.7Vcc		Vcc	V	
VIH	"H" input voltage	P00-P03, P31, P33, P34, P37, P50, P51, P54-P57, P60, P61	0.8Vcc		Vcc	V	
VIH	"H" input voltage	RESET	2.2 V ≤ Vcc ≤ 5.5 V	0.8Vcc		Vcc	V
			Vcc ≤ 2.2 V	$V_{cc} - \frac{65 \times V_{cc} - 99}{100}$		Vcc	
VIH	"H" input voltage	XIN	0.8Vcc		Vcc	V	
VIH	"H" input voltage	XCIN (Note 3)	1.5		Vcc	V	
VIL	"L" input voltage	P04-P07, P10-P17, P20-P27, P30, P32, P35, P36, P40-P47, P52, P53, P62	0		0.3Vcc	V	
VIL	"L" input voltage	P00-P03, P31, P33, P34, P37, P50, P51, P54-P57, P60, P61, CNVss	0		0.2Vcc	V	
VIL	"L" input voltage	RESET	2.2 V ≤ Vcc ≤ 5.5 V	0		0.2Vcc	V
			Vcc ≤ 2.2 V	0		$\frac{65 \times V_{cc} - 99}{100}$	
VIL	"L" input voltage	XIN	0		0.2Vcc	V	
VIL	"L" input voltage	XCIN (Note 4)	0		0.4	V	

Notes 1: When using the A-D converter, refer to "A-D Converter Characteristics".

2: The oscillation start voltage and the oscillation start time differ in accordance with an oscillator, a circuit constant, or temperature, etc. When power supply voltage is low and the high frequency oscillator is used, an oscillation start will require sufficient conditions.

f: This is an oscillator's oscillation frequency. For example, when oscillation frequency is 8 MHz, substitute "8".

3: When the XCIN/P61 pin is not connected to an oscillator, refer to VIH for P61.

4: When the XCIN/P61 pin is not connected to an oscillator, refer to VIL for P61.

Table 33 Recommended operating conditions (Mask ROM version)

(V_{CC} = 1.8 to 5.5 V, T_a = -20 to 85°C, unless otherwise noted)

Symbol	Parameter	Limits			Unit
		Min.	Typ.	Max.	
ΣIOH(peak)	"H" total peak output current (Note 1) P00-P07, P10-P17, P20-P27, P30-P37			-20	mA
ΣIOH(peak)	"H" total peak output current (Note 1) P40-P47, P50-P57, P60-P62			-20	mA
ΣIOL(peak)	"L" total peak output current (Note 1) P00-P07, P10-P17, P20-P27			20	mA
ΣIOL(peak)	"L" total peak output current (Note 1) P40-P47, P50, P51, P54-P57, P60-P62			20	mA
ΣIOL(peak)	"L" total peak output current (Note 1) P30-P37, P52, P53			110	mA
ΣIOH(avg)	"H" total average output current (Note 1) P00-P07, P10-P17, P20-P27, P30-P37			-10	mA
ΣIOH(avg)	"H" total average output current (Note 1) P40-P47, P50-P57, P60-P62			-10	mA
ΣIOL(avg)	"L" total average output current (Note 1) P00-P07, P10-P17, P20-P27			10	mA
ΣIOL(avg)	"L" total average output current (Note 1) P40-P47, P50, P51, P54-P57, P60-P62			10	mA
ΣIOL(avg)	"L" total average output current (Note 1) P30-P37, P52, P53			90	mA
IOH(peak)	"H" peak output current (Note 2) P00-P07, P10-P17, P20-P27			-1.0	mA
IOH(peak)	"H" peak output current (Note 2) P30-P37, P40-P47, P50-P57, P60-P62			-5.0	mA
IOL(peak)	"L" peak output current (Note 2) P00-P07, P10-P17, P20-P27			10	mA
IOL(peak)	"L" peak output current (Note 2) P40-P47, P50, P51, P54-P57, P60-P62			10	mA
IOL(peak)	"L" peak output current (Note 2) P30-P37, P52, P53			30	mA
IOH(avg)	"H" average output current (Note 3) P00-P07, P10-P17, P20-P27			-0.5	mA
IOH(avg)	"H" average output current (Note 3) P30-P37, P40-P47, P50-P57, P60-P62			-2.5	mA
IOL(avg)	"L" average output current (Note 3) P00-P07, P10-P17, P20-P27			5.0	mA
IOL(avg)	"L" average output current (Note 3) P40-P47, P50, P51, P54-P57, P60-P62			5.0	mA
IOL(avg)	"L" average output current (Note 3) P30-P37, P52, P53			15	mA

Notes 1: The total output current is the sum of all the currents flowing through all the applicable ports. The total average current is an average value measured over 100 ms. The total peak current is the peak value of all the currents.

2: The peak output current is the peak current flowing in each port.

3: The average output current is average value measured over 100 ms.

Table 34 Recommended operating conditions (Mask ROM version)

($V_{CC} = 1.8$ to 5.5 V, $T_a = -20$ to 85°C , unless otherwise noted)

Symbol	Parameter	Limits			Unit
		Min.	Typ.	Max.	
f(CNTR0)	Timer X and Timer Y	($4.5 \text{ V} \leq V_{CC} \leq 5.5 \text{ V}$)		5.0	MHz
f(CNTR1)	Input frequency (duty cycle 50%)	($4.0 \text{ V} \leq V_{CC} < 4.5 \text{ V}$)		$2 \times V_{CC} - 4$	MHz
		($2.0 \text{ V} \leq V_{CC} < 4.0 \text{ V}$)		V_{CC}	MHz
		($V_{CC} < 2.0 \text{ V}$)		$5 \times V_{CC} - 8$	MHz
f(Tclk)	Timer X, Timer Y, Timer 1, Timer 2, Timer 3 and Timer 4 Clock input frequency (Count source frequency of each timer)	($4.5 \text{ V} \leq V_{CC} \leq 5.5 \text{ V}$)		10.0	MHz
		($4.0 \text{ V} \leq V_{CC} < 4.5 \text{ V}$)		$4 \times V_{CC} - 8$	MHz
		($2.0 \text{ V} \leq V_{CC} < 4.0 \text{ V}$)		$2 \times V_{CC}$	MHz
		($V_{CC} < 2.0 \text{ V}$)		$10 \times V_{CC} - 16$	MHz
f(ϕ)	System clock ϕ frequency	($4.5 \text{ V} \leq V_{CC} \leq 5.5 \text{ V}$)		5.0	MHz
		($4.0 \text{ V} \leq V_{CC} < 4.5 \text{ V}$)		$2 \times V_{CC} - 4$	MHz
		($2.0 \text{ V} \leq V_{CC} < 4.0 \text{ V}$)		V_{CC}	MHz
		($V_{CC} < 2.0 \text{ V}$)		$5 \times V_{CC} - 8$	MHz
f(XIN)	Main clock input oscillation frequency (Notes 1, 3)	($4.5 \text{ V} \leq V_{CC} \leq 5.5 \text{ V}$)	1.0	10.0	MHz
		($2.0 \text{ V} \leq V_{CC} < 4.5 \text{ V}$)	1.0	8.0	MHz
		($V_{CC} < 2.0 \text{ V}$)	1.0	$20 \times V_{CC} - 32$	MHz
f(XCIN)	Sub-clock input oscillation frequency (Notes 1, 2, 3)		32.768	50	kHz

Notes 1: When the oscillation frequency has a duty cycle of 50%.

2: When using the microcomputer in low-speed mode, set the clock input oscillation frequency on condition that $f(XCIN) < f(XIN)/3$.

3: The oscillation start voltage and the oscillation start time differ in accordance with an oscillator, a circuit constant, or temperature, etc. When power supply voltage is low and the high frequency oscillator is used, an oscillation start will require sufficient conditions.

Electrical Characteristics

Table 35 Electrical characteristics (Mask ROM version)

(V_{CC} = 4.0 to 5.5 V, T_a = -20 to 85°C, unless otherwise noted)

Symbol	Parameter	Test conditions	Limits			Unit
			Min.	Typ.	Max.	
VOH	"H" output voltage P00-P07, P10-P17, P20-P27	IOH = -1 mA	V _{CC} -2.0			V
		IOH = -0.25 mA	V _{CC} -0.8			V
		V _{CC} = 1.8 V				
VOH	"H" output voltage P30-P37, P40-P47, P50-P57, P60-P62	IOH = -5 mA	V _{CC} -2.0			V
		IOH = -1.5 mA	V _{CC} -0.5			V
		IOH = -1.25 mA	V _{CC} -0.8			V
VOL	"L" output voltage P00-P07, P10-P17, P20-P27, P40-P47, P50, P51, P54-P57, P60-P62	IOL = 10 mA			2.0	V
		IOL = 3 mA			0.5	V
		IOL = 2.5 mA			0.8	V
		V _{CC} = 1.8 V				
VOL	"L" output voltage P30-P37, P52, P53	IOL = 15 mA			2.0	V
		IOL = 4 mA			0.8	V
		V _{CC} = 1.8 V				
VT+~VT-	Hysteresis INT0-INT2, CNTR0, CNTR1, P00-P03, P54-P57		0.5			V
VT+~VT-	Hysteresis SCLK1, SCLK2, RxD1, RxD2		0.5			V
VT+~VT-	Hysteresis $\overline{\text{RESET}}$		0.5			V
I _{IH}	"H" input current P00-P07, P10-P17, P20-P27, P30-P37, P40-P47, P50-P57, P60-P62	V _I = V _{CC}			5.0	μA
I _{IH}	"H" input current $\overline{\text{RESET}}$	V _I = V _{CC}			5.0	μA
I _{IH}	"H" input current X _{IN}	V _I = V _{CC}		4.0		μA
I _{IL}	"L" input current P00-P07, P10-P17, P20-P27, P30-P37, P40-P47, P50-P57, P60-P62	V _I = V _{SS} Pull-up "OFF"			-5.0	μA
		V _{CC} = 5.0 V, V _I = V _{SS} Pull-up "ON"	-60	-120	-240	μA
		V _{CC} = 1.8 V, V _I = V _{SS} Pull-up "ON"	-5.0	-20	-40	μA
I _{IL}	"L" input current $\overline{\text{RESET}}$	V _I = V _{SS}			-5.0	μA
I _{IL}	"L" input current X _{IN}	V _I = V _{SS}		-4.0		μA

Table 36 Electrical characteristics (Mask ROM version)

(V_{CC} = 1.8 to 5.5 V, T_a = -20 to 85°C, unless otherwise noted)

Symbol	Parameter	Test conditions	Limits			Unit
			Min.	Typ.	Max.	
VRAM	RAM hold voltage	When clock is stopped	1.8		5.5	V
ICC	Power source current	Frequency/2 mode, V _{CC} = 5 V f(XIN) = 10 MHz f(XCIN) = 32.768 kHz Output transistors "OFF", A-D converter in operating		3.4	5.1	mA
		Frequency/2 mode, V _{CC} = 5 V f(XIN) = 8 MHz f(XCIN) = 32.768 kHz Output transistors "OFF", A-D converter in operating		2.7	4.2	mA
		Frequency/2 mode, V _{CC} = 5 V f(XIN) = 8 MHz (in WIT state) f(XCIN) = 32.768 kHz Output transistors "OFF", A-D converter stopped		1.0	2.0	mA
		Low-speed mode, V _{CC} = 5 V, T _a ≤ 55 °C f(XIN) = stopped f(XCIN) = 32.768 kHz Output transistors "OFF"		14	21	μA
		Low-speed mode, V _{CC} = 5 V, T _a = 25 °C f(XIN) = stopped f(XCIN) = 32.768 kHz (in WIT state) Output transistors "OFF"		6	10	μA
		Low-speed mode, V _{CC} = 3 V, T _a ≤ 55 °C f(XIN) = stopped f(XCIN) = 32.768 kHz Output transistors "OFF"		8	13	μA
		Low-speed mode, V _{CC} = 3 V, T _a = 25 °C f(XIN) = stopped f(XCIN) = 32.768 kHz (in WIT state) Output transistors "OFF"		4	8	μA
		All oscillation stopped (in STP state) Output transistors "OFF"	T _a = 25 °C		0.1	1.0
	T _a = 85 °C			10	μA	

A-D Converter Characteristics

Table 37 A-D converter characteristics (Mask ROM version)

(V_{CC} = 2.2 to 5.5 V, V_{SS} = AV_{SS} = 0 V, T_a = -20 to 85°C, Port state = stopped, unless otherwise noted)

Symbol	Parameter	Test conditions	Limits			Unit
			Min.	Typ.	Max.	
—	Resolution				10	Bits
—	Absolute accuracy (quantification error excluded)	V _{CC} = V _{REF} = 5 V AD clock frequency = 5 MHz 10bitAD mode			±5	LSB
		V _{CC} = V _{REF} = 4 V AD clock frequency = 4 MHz 10bitAD mode				
		V _{CC} = V _{REF} = 2.2 V AD clock frequency = 500 kHz 10bitAD mode, booster effective			±4	
		V _{CC} = V _{REF} = 5 V AD clock frequency = 4 MHz 8bitAD mode			±2	
		V _{CC} = V _{REF} = 2.2 V AD clock frequency = 1 MHz 8bitAD mode, booster effective				
T _{conv}	Conversion time	AD conversion clock selection bit :XIN/2, 10bitAD mode			t _c (XIN)X121 (Note)	μs
RLADDER	Ladder resistor		12	35	100	kΩ
IVREF	Reference input current	V _{REF} = 5 V	50	150	200	μA
I _{IA}	Analog input current				5.0	μA

Note: When "Frequency/4, 8 or 16" is selected by the AD conversion clock selection bit, the above conversion time is multiplied by 2, 4 or 8.

LCD Power Supply Characteristics

Table 38 LCD power supply characteristics (when connecting division resistors for LCD power supply) (Mask ROM version)

(V_{CC} = 1.8 to 5.5 V, T_a = -20 to 85°C, unless otherwise noted)

Symbol	Parameter	Test conditions	Limits			Unit		
			Min.	Typ.	Max.			
RLCD	Division resistor for LCD power supply (Note)	RSEL = "10"		200		kΩ		
		RSEL = "11"		5				
		LCD drive timing A	LCD circuit division ratio = divided by 1	RSEL = "01"			120	
				RSEL = "00"			90	
			LCD circuit division ratio = divided by 2	RSEL = "01"			150	
				RSEL = "00"			120	
			LCD circuit division ratio = divided by 4	RSEL = "01"			170	
				RSEL = "00"			150	
			LCD circuit division ratio = divided by 8	RSEL = "01"			190	
				RSEL = "00"			170	
		LCD drive timing B	LCD circuit division ratio = divided by 1	RSEL = "01"			150	
				RSEL = "00"			120	
			LCD circuit division ratio = divided by 2	RSEL = "01"			170	
				RSEL = "00"			150	
			LCD circuit division ratio = divided by 4	RSEL = "01"			190	
				RSEL = "00"			170	
LCD circuit division ratio = divided by 8	RSEL = "01"			190				
	RSEL = "00"			190				

Note: The value is the average of each one division resistor.

Timing Requirements And Switching Characteristics

Table 39 Timing requirements 1 (Mask ROM version)

(Vcc = 4.0 to 5.5 V, Vss = 0 V, Ta = -20 to 85°C, unless otherwise noted)

Symbol	Parameter		Limits			Unit
			Min.	Typ.	Max.	
tw(RESET)	Reset input "L" pulse width		2			μs
tc(XIN)	Main clock input cycle time (XIN input)	(4.5 V ≤ Vcc ≤ 5.5 V)	100		1000	ns
		(4.0 V ≤ Vcc < 4.5 V)	1000/(4 × Vcc - 8)		1000	ns
twH(XIN)	Main clock input "H" pulse width	(4.5 V ≤ Vcc ≤ 5.5 V)	40		500	ns
		(4.0 V ≤ Vcc < 4.5 V)	45		500	ns
twL(XIN)	Main clock input "L" pulse width	(4.5 V ≤ Vcc ≤ 5.5 V)	40		500	ns
		(4.0 V ≤ Vcc < 4.5 V)	45		500	ns
tc(XCIN)	Sub clock input cycle time		20			μs
twH(XCIN)	Sub clock input "H" pulse width		9			μs
twL(XCIN)	Sub clock input "L" pulse width		9			μs
tc(CNTR)	CNTR0, CNTR1 input cycle time	(4.5 V ≤ Vcc ≤ 5.5 V)	200			ns
		(4.0 V ≤ Vcc < 4.5 V)	1000/(2 × Vcc - 4)			ns
twH(CNTR)	CNTR0, CNTR1 input "H" pulse width	(4.5 V ≤ Vcc ≤ 5.5 V)	85			ns
		(4.0 V ≤ Vcc < 4.5 V)	105			ns
twL(CNTR)	CNTR0, CNTR1 input "L" pulse width	(4.5 V ≤ Vcc ≤ 5.5 V)	85			ns
		(4.0 V ≤ Vcc < 4.5 V)	105			ns
twH(INT)	INT0-INT2 input "H" pulse width		80			ns
twL(INT)	INT0-INT2 input "L" pulse width		80			ns
tc(SCLK)	Serial I/O1, 2 clock input cycle time (Note)		800			ns
twH(SCLK)	Serial I/O1, 2 clock input "H" pulse width (Note)		370			ns
twL(SCLK)	Serial I/O1, 2 clock input "L" pulse width (Note)		370			ns
tsu(RxD-SCLK)	Serial I/O1, 2 input setup time		220			ns
th(SCLK-RxD)	Serial I/O1, 2 input hold time		100			ns

Note : When bit 6 of address 0FE016 or 0FE316 is "1" (clock synchronous).
 Divide this value by four when bit 6 of address 0FE016 or 0FE316 is "0" (UART).

PRELIMINARY
 Notice: This is not a final specification.
 Some parametric limits are subject to change.

MITSUBISHI MICROCOMPUTERS
38C2 Group (A Version)

SINGLE-CHIP 8-BIT CMOS MICROCOMPUTER

Table 40 Timing requirements 2 (Mask ROM version)

(Vcc = 1.8 to 4.0 V, Vss = 0 V, Ta = -20 to 85°C, unless otherwise noted)

Symbol	Parameter		Limits			Unit
			Min.	Typ.	Max.	
tw(RESET)	Reset input "L" pulse width		2			μs
tc(XIN)	Main clock input cycle time (XIN input)	2.0 V ≤ Vcc ≤ 4.0 V	125		1000	ns
		Vcc < 2.0 V	250/(5×Vcc-8)		1000	ns
twH(XIN)	Main clock input "H" pulse width	2.0 V ≤ Vcc ≤ 4.0 V	50		500	ns
		Vcc < 2.0 V	tc(XIN)/2-12.5		500	ns
twL(XIN)	Main clock input "L" pulse width	2.0 V ≤ Vcc ≤ 4.0 V	50		500	ns
		Vcc < 2.0 V	tc(XIN)/2-12.5		500	ns
tc(XCIN)	Sub clock input cycle time		20			μs
twH(XCIN)	Sub clock input "H" pulse width		9			μs
twL(XCIN)	Sub clock input "L" pulse width		9			μs
tc(CNTR)	CNTR0, CNTR1 input cycle time	2.0 V ≤ Vcc ≤ 4.0 V	1000/Vcc			ns
		Vcc < 2.0 V	1000/(5×Vcc-8)			ns
twH(CNTR)	CNTR0, CNTR1 input "H" pulse width		tc(CNTR)/2-20			ns
twL(CNTR)	CNTR0, CNTR1 input "L" pulse width		tc(CNTR)/2-20			ns
twH(INT)	INT0-INT2 input "H" pulse width		230			ns
twL(INT)	INT0-INT2 input "L" pulse width		230			ns
tc(SCLK)	Serial I/O1, 2 clock input cycle time (Note)		2000			ns
twH(SCLK)	Serial I/O1, 2 clock input "H" pulse width (Note)		950			ns
twL(SCLK)	Serial I/O1, 2 clock input "L" pulse width (Note)		950			ns
tsu(RxD-SCLK)	Serial I/O1, 2 input setup time		400			ns
th(SCLK-RxD)	Serial I/O1, 2 input hold time		200			ns

Note : When bit 6 of address 0FE016 or 0FE316 is "1" (clock synchronous).
 Divide this value by four when bit 6 of address 0FE016 or 0FE316 is "0" (UART).

Table 41 Switching characteristics 1 (Mask ROM version)

(V_{CC} = 4.0 to 5.5 V, V_{SS} = 0 V, T_a = -20 to 85°C, unless otherwise noted)

Symbol	Parameter	Limits			Unit
		Min.	Typ.	Max.	
t _{wH} (SCLK)	Serial I/O1, 2 clock output "H" pulse width	t _c (SCLK)/2-30			ns
t _{wL} (SCLK)	Serial I/O1, 2 clock output "L" pulse width	t _c (SCLK)/2-30			ns
t _d (SCLK-TxD)	Serial I/O1, 2 output delay time (Note 1)			140	ns
t _v (SCLK-TxD)	Serial I/O1, 2 output valid time (Note 1)	-30			ns
t _r (SCLK)	Serial I/O1, 2 clock output rising time			30	ns
t _f (SCLK)	Serial I/O1, 2 clock output falling time			30	ns
t _r (CMOS)	CMOS output rising time	P00-P07, P10-P17, P20-P27 (Note 2)	25	40	ns
		P30-P37, P40-P47, P50-P57, P60-P62 (Note 2)	15	30	ns
t _f (CMOS)	CMOS output falling time	P00-P07, P10-P17, P20-P27 (Note 2)	15	30	ns
		P30-P37, P40-P47, P50-P57, P60-P62 (Note 2)			

Notes 1: When the P-channel output disable bit (bit 4 of address 0FE116 or 0FE416) is "0."

2: The XOUT, XCOUNT pins are excluded.

Table 42 Switching characteristics 2 (Mask ROM version)

(V_{CC} = 1.8 to 4.0 V, V_{SS} = 0 V, T_a = -20 to 85°C, unless otherwise noted)

Symbol	Parameter	Limits			Unit
		Min.	Typ.	Max.	
t _{wH} (SCLK)	Serial I/O1, 2 clock output "H" pulse width	t _c (SCLK)/2-80			ns
t _{wL} (SCLK)	Serial I/O1, 2 clock output "L" pulse width	t _c (SCLK)/2-80			ns
t _d (SCLK-TxD)	Serial I/O1, 2 output delay time (Note 1)			400	ns
t _v (SCLK-TxD)	Serial I/O1, 2 output valid time (Note 1)	-30			ns
t _r (SCLK)	Serial I/O1, 2 clock output rising time			80	ns
t _f (SCLK)	Serial I/O1, 2 clock output falling time			80	ns
t _r (CMOS)	CMOS output rising time	P00-P07, P10-P17, P20-P27 (Note 2)	60	120	ns
		P30-P37, P40-P47, P50-P57, P60-P62 (Note 2)	40	80	ns
t _f (CMOS)	CMOS output falling time	P00-P07, P10-P17, P20-P27 (Note 2)	40	80	ns
		P30-P37, P40-P47, P50-P57, P60-P62 (Note 2)			

Notes 1: When the P-channel output disable bit (bit 4 of address 0FE116 or 0FE416) is "0."

2: The XOUT, XCOUNT pins are excluded.

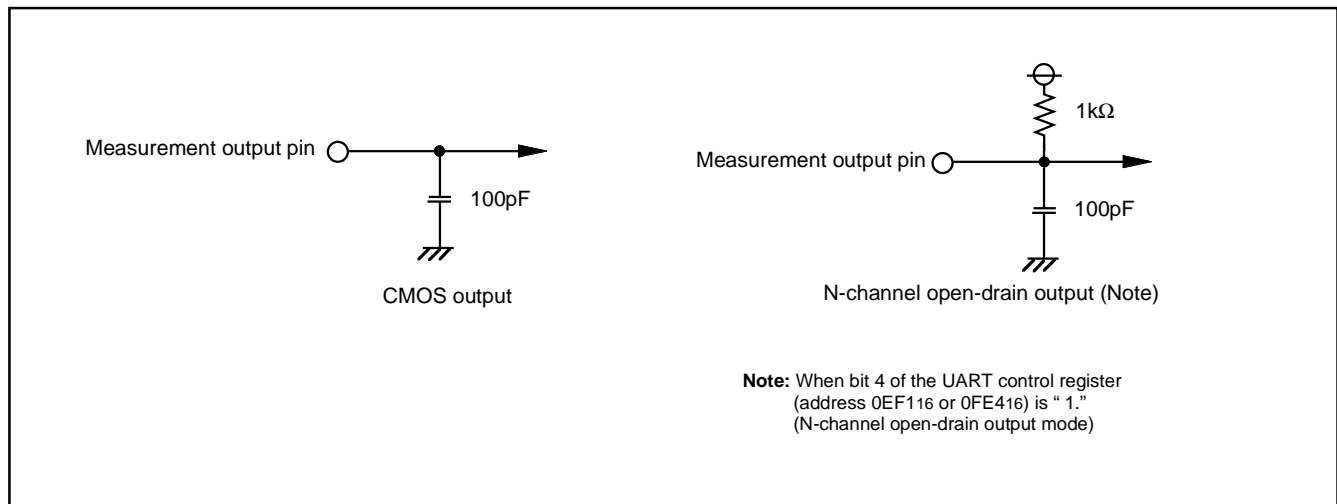

Fig. 85 Circuit for measuring output switching characteristics

PRELIMINARY
 Notice: This is not a final specification.
 Some parametric limits are subject to change.

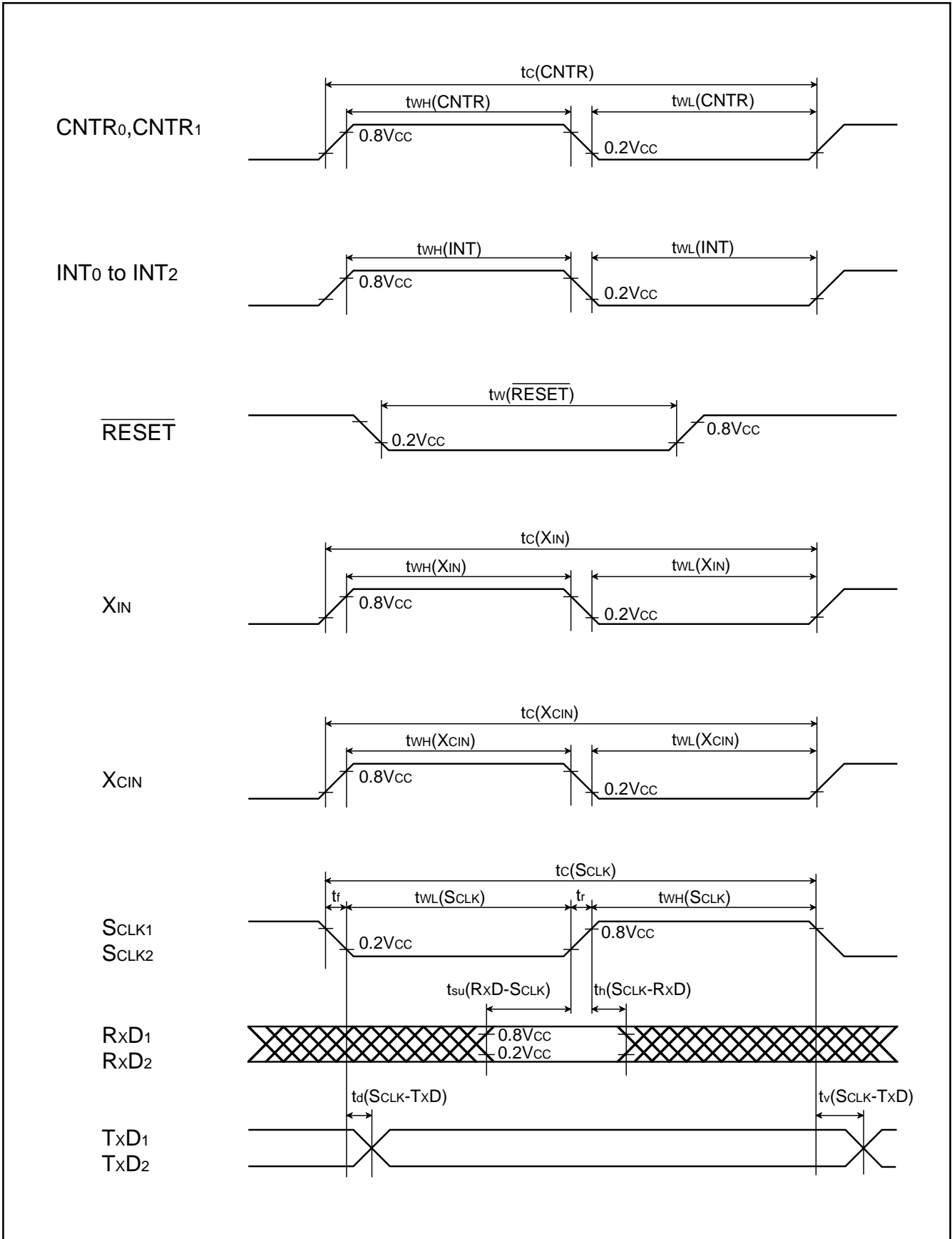

Fig. 86 Timing chart

PRELIMINARY
 Notice: This is not a final specification.
 Some parametric limits are subject to change.

MITSUBISHI MICROCOMPUTERS
38C2 Group (A Version)

SINGLE-CHIP 8-BIT CMOS MICROCOMPUTER

PACKAGE OUTLINE

64P6U-A

(MMP)

Plastic 64pin 14X14mm body LQFP

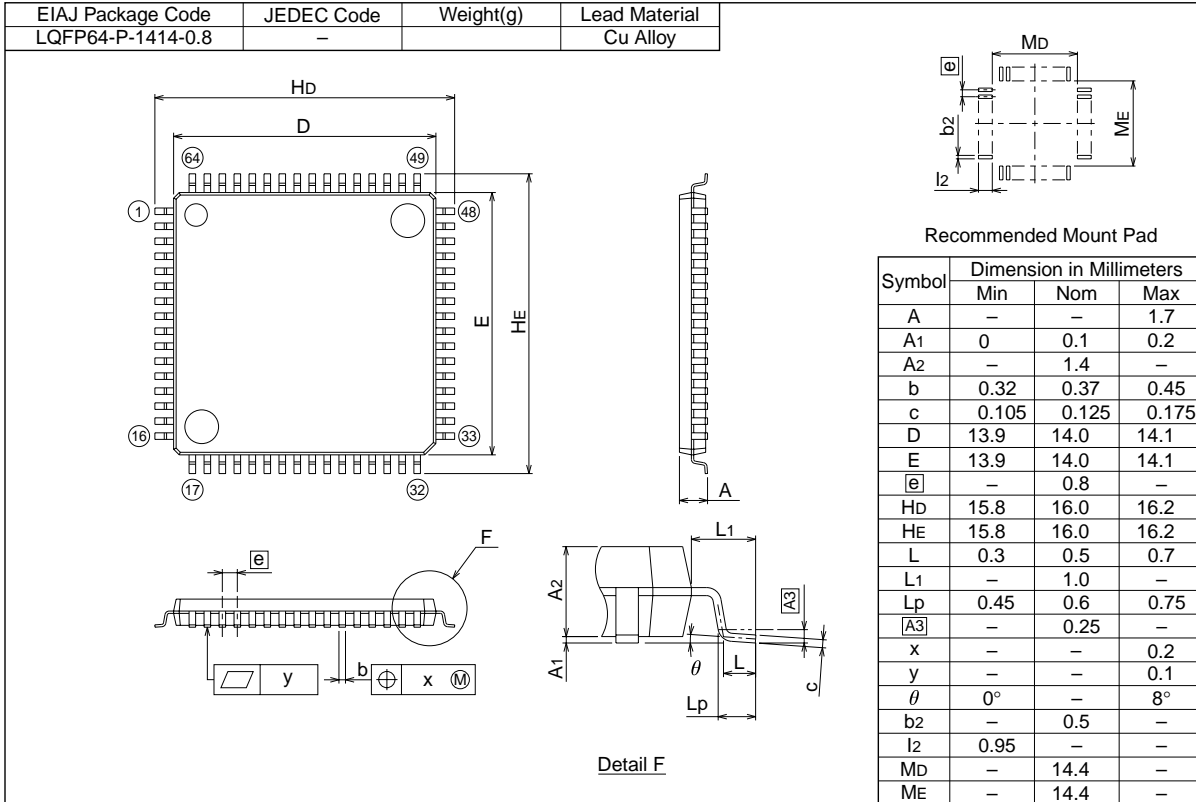

64P6Q-A

Plastic 64pin 10X10mm body LQFP

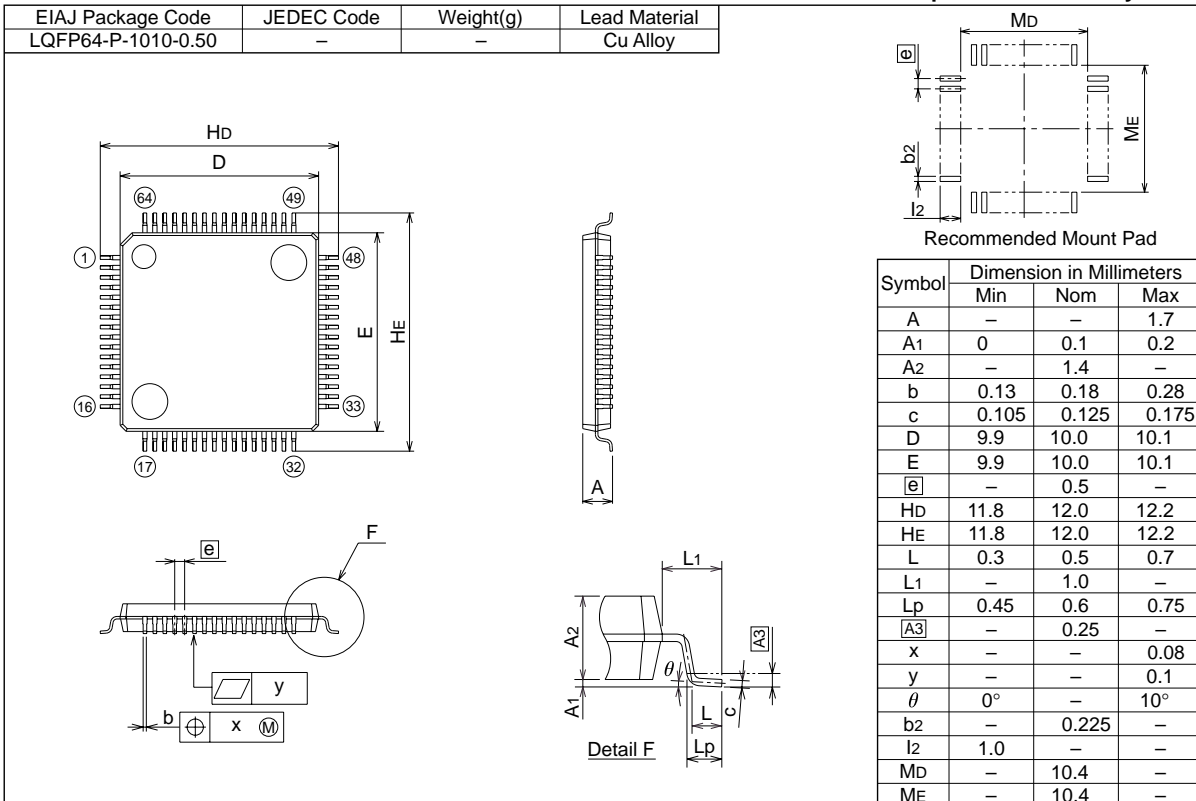

PRELIMINARY
Notice: This is not a final specification.
Some parametric limits are subject to change.

MITSUBISHI MICROCOMPUTERS

38C2 Group (A Version)

SINGLE-CHIP 8-BIT CMOS MICROCOMPUTER

Renesas Technology Corp.

Nippon Bldg., 6-2, Otemachi 2-chome, Chiyoda-ku, Tokyo, 100-0004 Japan

Keep safety first in your circuit designs!

- Mitsubishi Electric Corporation puts the maximum effort into making semiconductor products better and more reliable, but there is always the possibility that trouble may occur with them. Trouble with semiconductors may lead to personal injury, fire or property damage. Remember to give due consideration to safety when making your circuit designs, with appropriate measures such as (i) placement of substitutive, auxiliary circuits, (ii) use of non-flammable material or (iii) prevention against any malfunction or mishap.

Notes regarding these materials

- These materials are intended as a reference to assist our customers in the selection of the Mitsubishi semiconductor product best suited to the customer's application; they do not convey any license under any intellectual property rights, or any other rights, belonging to Mitsubishi Electric Corporation or a third party.
- Mitsubishi Electric Corporation assumes no responsibility for any damage, or infringement of any third-party's rights, originating in the use of any product data, diagrams, charts, programs, algorithms, or circuit application examples contained in these materials.
- All information contained in these materials, including product data, diagrams, charts, programs and algorithms represents information on products at the time of publication of these materials, and are subject to change by Mitsubishi Electric Corporation without notice due to product improvements or other reasons. It is therefore recommended that customers contact Mitsubishi Electric Corporation or an authorized Mitsubishi Semiconductor product distributor for the latest product information before purchasing a product listed herein. The information described here may contain technical inaccuracies or typographical errors. Mitsubishi Electric Corporation assumes no responsibility for any damage, liability, or other loss arising from these inaccuracies or errors. Please also pay attention to information published by Mitsubishi Electric Corporation by various means, including the Mitsubishi Semiconductor home page (<http://www.mitsubishichips.com>).
- When using any or all of the information contained in these materials, including product data, diagrams, charts, programs, and algorithms, please be sure to evaluate all information as a total system before making a final decision on the applicability of the information and products. Mitsubishi Electric Corporation assumes no responsibility for any damage, liability or other loss resulting from the information contained herein.
- Mitsubishi Electric Corporation semiconductors are not designed or manufactured for use in a device or system that is used under circumstances in which human life is potentially at stake. Please contact Mitsubishi Electric Corporation or an authorized Mitsubishi Semiconductor product distributor when considering the use of a product contained herein for any specific purposes, such as apparatus or systems for transportation, vehicular, medical, aerospace, nuclear, or undersea repeater use.
- The prior written approval of Mitsubishi Electric Corporation is necessary to reprint or reproduce in whole or in part these materials.
- If these products or technologies are subject to the Japanese export control restrictions, they must be exported under a license from the Japanese government and cannot be imported into a country other than the approved destination. Any diversion or reexport contrary to the export control laws and regulations of Japan and/or the country of destination is prohibited.
- Please contact Mitsubishi Electric Corporation or an authorized Mitsubishi Semiconductor product distributor for further details on these materials or the products contained therein.

