

RF Directional Couplers and 3dB Hybrids

Overview

M560

V2.00

Directional Couplers

- For providing a sample of the power propagating in one direction on a transmission line.

3dB Hybrids

- For dividing a signal into two signals of equal amplitude and a constant 90° or 180° phase differential.
- For quadrature combining or performing summation/differential combining.

Introduction

Couplers and hybrids are devices in which two transmission lines pass close enough to each other for energy propagating on one line to couple to the other line. A 3dB 90° or 180° hybrid splits an input signal into two equal amplitude outputs. A directional coupler normally splits an input signal into two unequal amplitude outputs. This terminology “directional

coupler”, “90° hybrid”, and “180° hybrid” is based on convention. However, the 90° and 180° hybrids could be thought of as 3 dB directional couplers. Despite these similarities, the parameters used to describe signal flow in directional couplers and the application, in actual use, is sufficiently different to warrant separate considerations.

180° Hybrids Functional Description

A 180° hybrid is a reciprocal four-port device which provides two equal amplitude in-phase signals when fed from its sum port (Σ) and two equal amplitude 180° out-of-phase signals when fed from its difference port (Δ). Conversely, signals input into ports C and D will add at the sum port (B) and the difference of the two signals will appear at the difference port (A). **Figure 1** is a functional diagram which will be used in this article to represent the 180° hybrid. Port B can be considered the sum port and port A is the difference port. Ports A and B and ports C and D are isolated pairs of ports.

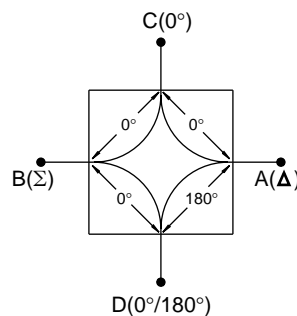

Figure 1a: RF Frequencies
(Up to 2000 MHz)

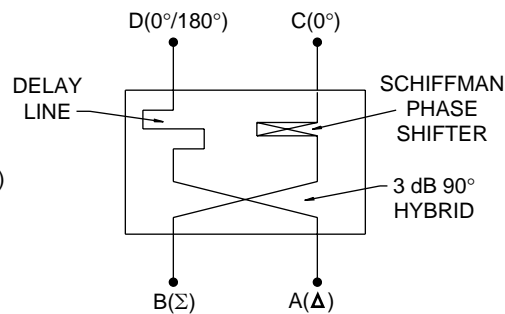

Figure 1b: Microwave Frequencies
(500 MHz and Up)

The RF and microwave frequency devices are designed and realized using different theory, techniques, and media. The RF frequency devices utilize coupled wound coils on ferrite cores. The microwave frequency devices are constructed using microstrip or stripline technology and consist of a 3 dB coupler feeding a Schiffman phase shifter and a delay line. Some ultra broadband units utilize a tandem 8.34 dB coupler “Magic T” configuration as shown below in **Figure 2**.

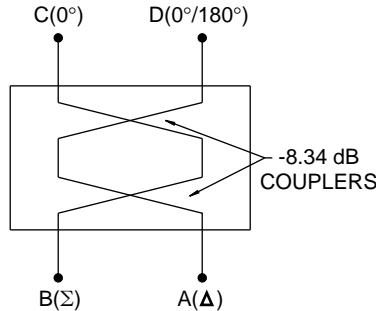

Figure 2. Magic T 180° Hybrid

These three different approaches yield nearly similar results with minor differences that will be discussed later.

Utilizing the functional diagrams of **Figure 1**, we can consider the application of signal at one or more of the ports of the hybrid. The cases that are important to consider are the following:

1. Operation as a power divider - One source operating at ports A, B, C or D.
2. Operation as a power summer - Two sources operating at ports A and B, or C and D.

For these cases, the impedances Z_A , Z_B , Z_C , and Z_D , are assumed to be Z_0 , the characteristic impedance of the 180° hybrid. Under this matched condition, the source voltage of $2E \cos(\omega t)$ will supply a voltage of $E \cos(\omega t)$ to the input of the hybrid.

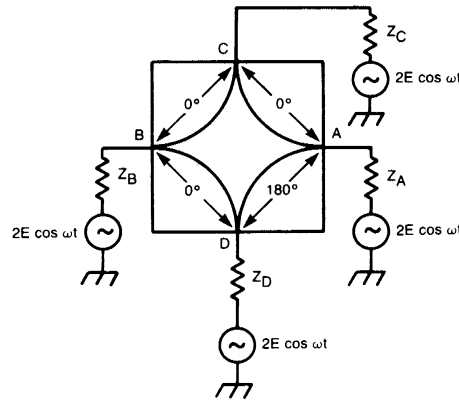

Figure 3. Signal Source Configurations for 180° Hybrid (Reference Tables I, II, III)

As a power divider, the hybrid will equally split the input signal and deliver one half the power to each load. Since all ports are considered to be at Z_0 impedance, the voltages at the outputs will be proportional to the square root of the output power and will be phase shifted by the amount indicated for that path of the hybrid, since $P_{out} = 1/2 P_{in}$, $V_{out} = 0.707 V_{in}$. For example, if an input signal at Port A of $E \cos(\omega t)$ is injected, the resultant output at Port C is $0.707 E \cos(\omega t)$ and the output at Port D is $0.707 E \cos(\omega t - 180^\circ)$. No signal will appear at Port B because it is isolated from A. The various power divider relationships are summarized in **Table 1**.

Table 1 - Power Divider Relationships for 180° Hybrids

Input Signal	Input Port	Output Signals			
		Port A	Port B	Port C	Port D
$E \cos(\omega t)$	A	–	0	$0.707 E \cos(\omega t)$	–
	B	0	–	$0.707 E \cos(\omega t)$	$0.707 E \cos(\omega t)$
	C	$0.707 E \cos(\omega t)$	$0.707 E \cos(\omega t)$	–	0
	D	$0.707 E \cos(\omega t - 180^\circ)$	$0.707 E \cos(\omega t)$	0	–

- 1) This chart assumes only one generator at a time is operating.
- 2) Infinite isolation is assumed in the hybrid junction.
- 3) This is only applicable to RF and Magic T configurations. (Figures 1a and 2) for Microwave frequency Schiffman - type 180° hybrids, use Table 1A.

Table 1A - Power Divider Relationships for Schiffman style 180° hybrids assuming one input only.

Input Signal	Input Port	Output Signals			
		Port A	Port B	Port C	Port D
E cos(ωt)	A	–	0	0.707 E cos(ωt)	0.707 E cos(ωt-180°)
	B	0	–	0.707 E cos(ωt)	0.707 E cos(ωt)
	C	0.707 E cos(ωt)	0.707 E cos(ωt-90°)	–	0
	D	0.707 E cos(ωt-90°)	0.707 E cos(ωt)	0	–

The microwave frequency “Schiffman style” device has slightly different power dividing characteristics when fed with one input only into port C or D. This performance is outline in **Table 1A**.

This difference in performance from **Table 1** is a direct result of the non-symmetrical design of the Schiffman style device. This changes the performance for the one input condition only. When two signals are input for a summing/difference operation as described below, this device behaves the same as the RF or magic tee device shown in **Figure 1a** and **2**.

When used as a power summer, the function of the 180° hybrid is somewhat less obvious due to the vector addition of the two signals. **Figure 4** shows the signal flow and resultant outputs for the general case of two equal amplitude, equal frequency signals of arbitrary phase. The vector representation of the input signals as well as the resultant output signals is shown graphically below in **Figure 4**. In general terms, the two signals input into ports C and D of a 180° hybrid vectorally add at port B (the sum port) and vectorally subtract at port A (the delta port).

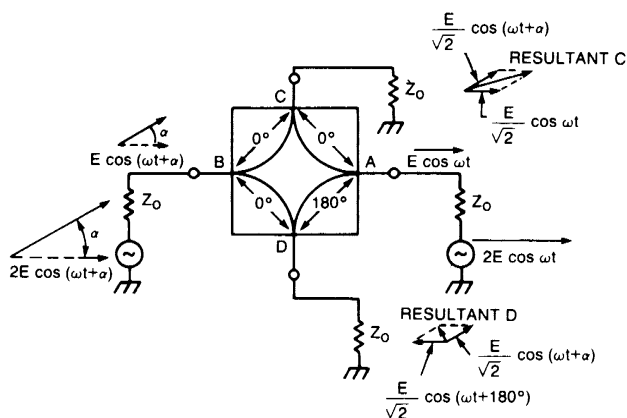

Figure 4: Graphical representation of sum and difference operation of 180° hybrid

So, if identical (coherent) signals are inputted into ports C and D, they will add and appear at port B while no signal will appear at port A. Conversely, if the same input signals are 180° out of phase with each other, all of the power will appear at port A.

Table II and **III** provide useful relations for determining isolation and VSWR under varying loading conditions. One point to note from the expressions in these tables is that equal mismatches on opposite ports of the hybrid do not affect isolation because the reflected signal will cancel at the isolated port while they will add at the port where the signal is injected. For example, if we inject a signal at Port A with equal mismatches at Ports C and D ($P_C = P_D$), then no signal will appear at Port B because the reflected components are 180° out-of-phase. The VSWR at Port A will be degraded because the reflections add in at this port. In general, equal mismatches may not be present. The relations in **Tables II** and **III** may be used to calculate VSWR and isolation for any known combination of load impedance.

Terminations				Isolation (dB)	
A	B	C	D	A to B	C to D
Z_0	Z_0	Z_C	Z_D	$6+20 \log \frac{1}{ P_C \cdot P_D }$	∞
Z_0	Z_0	Z_0	Z_D	$6+20 \log \frac{1}{ P_D }$ = 6+ Return Loss of Z_D	∞
Z_A	Z_B	Z_0	Z_0	∞	$6+20 \log \frac{1}{ P_B \cdot P_A }$
Z_0	Z_B	Z_0	Z_0	∞	$6+20 \log \frac{1}{ P_B }$ = 6+ Return Loss of Z_B

Table II -- Isolation Between Ports of 180° Hybrids

- 1) Assumes only one generator is operating at a time.
- 2) $P = \frac{Z - Z_0}{Z + Z_0}$



Port Terminations				VSWR	
A	B	C	D	A to B	C to D
Z_0	Z_0	Z_0	Z_0	1:1	1:1
Z_0	Z_0	Z_0	Z_0	1:1	$1 + \frac{ P_A + P_B }{2}$
Z_0	Z_0	Z_0	Z_0	$\frac{1 + \frac{ P_C + P_B }{2}}{1 + \frac{ P_C + P_B }{2}}$	1:1

Table III – VSWR with Various Terminations for 180° Hybrids

Applications of 180° hybrids include monopulse comparitors (in monopulse radar systems), mixers, power combiners, power dividers, modulators and phased array radar antenna systems.

90° Hybrids

90° Hybrids or hybrid couplers are basically 3 dB directional couplers in which the phase of the coupled output signal and the output signal are 90° apart.

Since -3 dB represents half power, a 3 dB coupler divides the power equally (within a certain tolerance) between the output and coupled output ports. The 90° phase difference between the outputs makes hybrids useful in the design of electronically variable attenuators, microwave mixers, modulators and many other microwave components and systems.

Figure 5 shows the circuit diagram and truth table that will be used in explaining the operation of the RF frequency 90° hybrid. As can be seen from this diagram, a signal applied to any input will result in two equal amplitude signals that are quadrature, or 90°, out of phase with each other. Ports A and B and Ports C and D are isolated.

As previously stated in the 180° hybrid section, the RF and microwave frequency devices employ different construction methods. Although the theoretical responses are identical, the port location and convention is different. Below, in **Figure 6** are “cross-over” and “non-crossover” versions offered for microwave frequencies (500 MHz and up) and the resulting truth table.

Ninety degree hybrids are also called quadrature hybrids because the phase of the two outputs are a quadrant (90°) apart. Note also that it does not make any difference which port is the input port as long as the relationship between ports remains. This is because the 90° hybrids are electrically and mechanically symmetrical about both the X and Y axes.

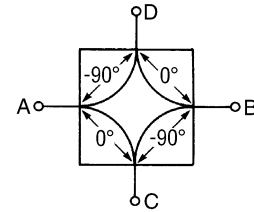

	A	B	C	D
A	ISO.	ISO.	0	-90
B	ISO.	ISO.	-90	0
C	0	-90	ISO.	ISO.
D	-90	0	ISO.	ISO.

ISO. = ISOLATION

Figure 5. RF Frequency 90° Hybrid Schematic and Phase Truth Table

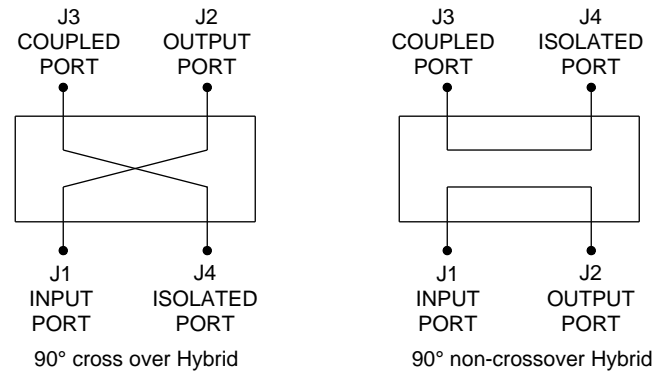

	J1	J2	J3	J4
J1	X	-90°	0°	ISO
J2	-90°	X	ISO	0°
J3	0°	ISO	X	-90°
J4	ISO	0°	-90°	X

Figure 6. Microwave Frequency 90° Hybrid Schematics and Phase Truth Table

Following an analysis similar to that applied to the 180° hybrid, we can apply signal sources in various combinations to ports of the 90° hybrid and determine the resultant outputs. **Figure 7** shows the arrangement used for this analysis, and once again we will consider the operation of the hybrid as a power divider and power summer, with all terminating impedances assumed equal to Z_0 .

The analysis of the 90° hybrid as a power divider is straightforward and as previously mentioned, two equal amplitude outputs result when any one of the ports is fed by a signal source. These outputs are in quadrature as indicated in **Table IV**.

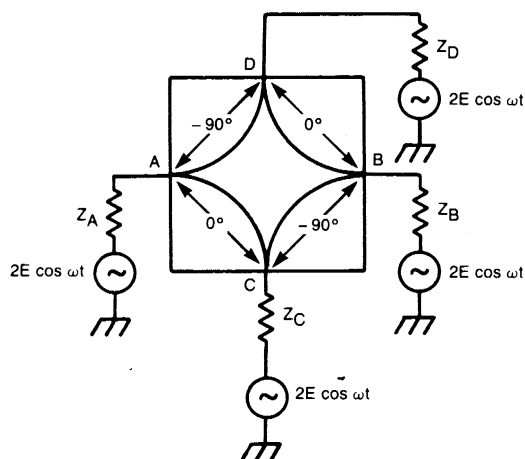

Figure 7. Signal Source Configuration for 90° Hybrid (Reference Tables IV, V, VI, VII)

Input Signal	Input Port	Output Signals			
		Port A	Port D	Port C	Port B
Ecosωt	A		$\frac{E \cos(\omega t - 90^\circ)}{\sqrt{2}}$	$\frac{E \cos \omega t}{\sqrt{2}}$	0
	B	$\frac{E \cos(\omega t - 90^\circ)}{\sqrt{2}}$		0	$\frac{E \cos \omega t}{\sqrt{2}}$
	C	$\frac{E \cos \omega t}{\sqrt{2}}$	0		$\frac{E \cos(\omega t - 90^\circ)}{\sqrt{2}}$
	D	0	$\frac{E \cos \omega t}{\sqrt{2}}$	$\frac{E \cos(\omega t - 90^\circ)}{\sqrt{2}}$	

Table IV - 90° Hybrid as a Power Divider

- 1) Only one generator is operating at a time
- 2) For microwave frequency 3 dB 90° hybrids, Port A = J1, Port B = J4, Port C = J2, Port D = J3

To analyze the 90° hybrid as a power summer, we will once again make use of a diagram showing the vector relationships of the signals at all ports when two equal amplitude, equal frequency, arbitrary phase signals are applied.

In **Figure 8**, these two signals are shown applied to Ports A and B of the 90° hybrid. The amplitudes of the resultant outputs at Ports C and D vary based on the phase of the inputs, while the phase of the outputs are always equal. This can be a useful property in certain applications since the relative phase of the input signals can be determined by measuring the relative amplitudes of the outputs. The relationships for a 90° hybrid with signals applied to Ports A and B or C and D are shown in **Table V**.

Tables VI and VII provide the relations for analysis of VSWR and Isolation in 90° hybrids. If we consider the same condition described for the 180° hybrid, two equal mismatches in opposite ports of the hybrid, we get an interesting result. The reflected signal will appear at the

normally isolated port, but will not be present at the input. Thus, if we inject a signal at Port A, and apply equal mismatches at Ports C and D with a Z_0 termination at Port B, the reflected components from the mismatches will be in phase at Port B and will be 180° out of phase at Port A. The isolation between Ports A and B is reduced, but the VSWR at Port A is unchanged by the presence of the mismatches. This property allows 90° hybrids to be used in applications such as balanced amplifiers, where two equal impedance but mismatched amplifier stages are combined at inputs and outputs with 90° hybrids to achieve a low VSWR. VSWR and Isolation can be determined based on the relationships in **Tables VI and VII**.

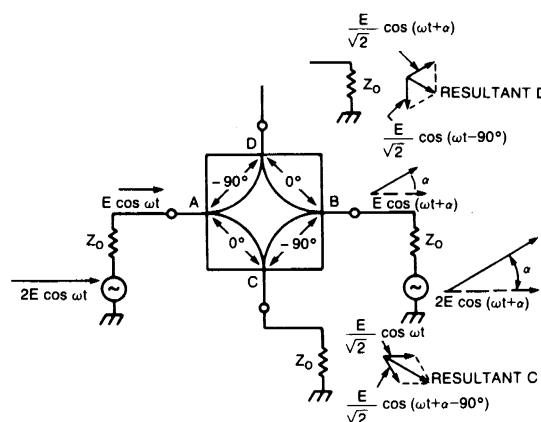

Figure 8. 90° Hybrid

Input Signal	Input Port	Port A	Output Ports		Port B
			Port D	Port C	
E cos ωt	A		$\sqrt{2} E \cos(-45^\circ - a/2)$	$\sqrt{2} E \cos(45^\circ - a/2)$	
E cos(ωt+a)	B		$ \cos(\omega t + a/2 - 45^\circ) $	$ \cos(\omega t + a/2 - 45^\circ) $	
E cos ωt	A		0	$\sqrt{2} E \cos \omega t$	
E cos ωt	B				
E cos(ωt+90°)	A		$\sqrt{2} E \cos \omega$		0
E cos ωt	D				$\sqrt{2} E \cos \omega t$
E cos(ωt+90°)	C	0			
E cos ωt	D	$\sqrt{2} E \cos \omega t$			0
E cos(ωt+90°)	C				
E cos ω ₁ t	B		$\frac{E}{\sqrt{2}} \left[\begin{matrix} \cos \omega_1 t + \\ \cos(\omega_2 t - 90^\circ) \end{matrix} \right]$	$\frac{E}{\sqrt{2}} \left[\begin{matrix} \cos(\omega_1 t + 90^\circ) + \\ \cos(\omega_2 t) \end{matrix} \right]$	
E cos ω ₁ t	A				

Table V - 90° Hybrid as a Power Summer

- 1) Two generators are operating simultaneously
- 2) For microwave frequency devices, Port A = J1, Port B = J4, Port C = J2, Port D = J3

Port Terminations				Port VSWR's			
A	B	C	D	Port A	Port D	Port C	Port B
Z ₀	Z ₀	Z ₀	Z ₀	1:1	1:1	1:1	1:1
Z ₀	Z _D	Z _C	Z ₀	$1 + \frac{ P_D - P_C }{2}$ $1 - \frac{ P_D - P_C }{2}$	1:1	1:1	$1 + \frac{ P_D - P_C }{2}$ $1 - \frac{ P_D - P_C }{2}$
Z _A	Z ₀	Z ₀	Z _B	1:1	$1 + \frac{ P_A - P_B }{2}$ $1 - \frac{ P_A - P_B }{2}$	$1 + \frac{ P_A - P_B }{2}$ $1 - \frac{ P_A - P_B }{2}$	

Table VI - VSWR of 90° Hybrids

$$P = \frac{Z - Z_0}{Z + Z_0}$$

Terminations				Isolation (dB)	
A	B	C	D	Ports A to B	Ports C to D
Z ₀	Z ₀	Z ₀	Z ₀	∞	∞
Z ₀	Z ₀	Z _C	Z _D	$6 + 20 \log \frac{1}{ P_D + P_C }$	∞
Z ₀	Z _D	Z ₀	Z ₀	$6 + 20 \log \frac{1}{ P_D } = 6 + \text{return loss of } Z_D$	∞
Z _A	Z ₀	Z ₀	Z _B	∞	$6 + 20 \log \frac{1}{ P_B + P_A }$
Z ₀	Z ₀	Z ₀	Z _B	∞	$6 + 20 \log \frac{1}{ P_B } = 6 + \text{return loss of } Z_B$

Table VII - Isolation for 90° Hybrids

1. Only one generator at a time is operating.

$$2. P = \frac{Z - Z_0}{Z + Z_0}$$

$$3. \text{Return Loss} = 20 \log \frac{1}{|P|}$$

Performance Parameters for - 3 dB 90° and 180° Hybrid Couplers

The 180° or 90° hybrid electrical parameters of principal importance to the designer or components engineer and commonly specified by manufacturers are the following:

Frequency Range

This is the range over which specifications are guaranteed for the particular device.

Insertion Loss

The amount of attenuation, in excess of signal splitting losses, of an an input signal from a source of characteristic impedance Z₀ measured at an output port terminated in Z₀.

Isolation

Isolation between two ports of a passive device is the amount of attenuation that a signal from a source of characteristic impedance Z₀ applied to one port undergoes when measured at the other port terminated in Z₀.

Impedance

This is the nominal characteristic impedance (Z₀) for the device.

VSWR

Voltage Standing Wave Ratio (VSWR) is a measure of the impedance of a device relative to Z₀.

$$\text{It can be expressed as } \text{VSWR} = \frac{1 + |P|}{1 - |P|}$$

where |P| is the magnitude of the reflection coefficient at the frequency of interest.

Amplitude Balance

The difference in attenuation between two or more output signals fed from a common input generally expressed as a maximum variation.

Phase Balance

The difference in phase between two or more output signals fed from a common input generally expressed as a maximum variation relative to the nominal phase difference between the paths. This nominal phase difference may be 0, 90, or 180°.

Some performance tradeoffs may be made between certain of these parameters. The principal tradeoff is between frequency range, insertion loss and amplitude balance for 90° hybrids. Several different design approaches are used for quadrature hybrids. These can generally be separated into narrow band and broadband designs. For single frequency applications the 10% bandwidth design can achieve very low insertion loss (0.1 to 0.2 dB), but the amplitude balance will degrade rapidly away from the center frequency. Octave bandwidth designs have more loss, but the amplitude balance is maintained over the octave range. For this design, two crossover points occur where the output signals are equal. The broadband design is normally used only where frequency ranges of a decade or more are required. It is a more complex design generally consisting of a pair of 180° hybrids interconnected with a pair of phase tracking 90° all pass lattice filter networks, and will usually have higher insertion loss because of this complexity. As a general rule, the device will become larger as the bandwidth is increased or the operating frequency is lowered.



Directional Couplers Functional Description

A directional coupler is a 4 port device in which two transmission lines pass close enough to each other for energy propagating on one line to couple to the other line. Unlike the 3 dB 90° and 180° hybrids previously discussed, the result of a directional coupler is two unequal amplitude outputs. Directional couplers are usually described by indicating the coupling ratio which is the ratio of the power appearing at the coupled port to the input power. For instance, a 10 dB coupler is shown below in **Figure 9**.

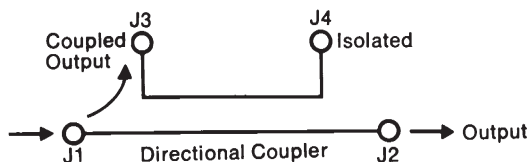

Figure 9. Directional Coupler

Power incident upon port 1 is partially coupled to port 3. In a 10 dB coupler the power at port 3, referenced to the input, will be -10 dB (1/10 the power). The remaining 9/10 of the power (.46 dB loss) will pass through the coupler to the output port (port 2). Port 4, the “isolated” port, will receive no power in an ideal coupler. Similarly, power incident to port 2 would couple to port 4 with port 3 being isolated and J1 would become the low-loss output.

If we assume a lossless condition, then the signal splitting losses are easily determined knowing only the coupling ratio. Using the equations below, a calculation of the losses can be easily performed for any given coupling ratio, with **Table VIII** providing the power splitting losses for several common coupling ratios.

$$\text{Coupling Ratio (dB)} = 10 \log \frac{P_{\text{out}} (\text{coupled path})}{P_{\text{in}}}$$

$$\text{Main line loss} = 10 \log \frac{P_{\text{out}} (\text{Main Line})}{P_{\text{in}}}$$

Table VIII

This main line loss vs. coupling is represented graphically

Coupling Ratio	Coupled Path Output (dB)	Coupled Path Power Ratio	Main Line Power Ratio	Main Line Loss
3 dB	-3 dB	0.50 P _{IN}	0.50 P _{IN}	3.0 dB
6 dB	-6 dB	0.25 P _{IN}	0.75 P _{IN}	1.25 dB
10 dB	-10 dB	0.10 P _{IN}	0.90 P _{IN}	0.46 dB
20 dB	-20 dB	0.01 P _{IN}	0.99 P _{IN}	0.04 dB
30 dB	-30 dB	0.001 P _{IN}	0.999 P _{IN}	0.004 dB

below:

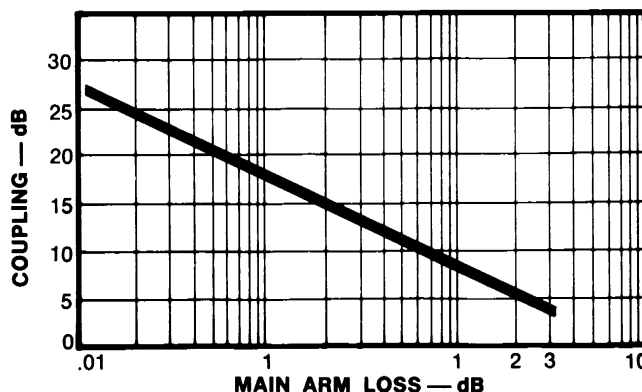

A “Directional Coupler” has the ability to separate and sample signal components based on the direction of signal flow. Referring to **Figure 10**, the diagram shows a 20 dB directional coupler with a signal source at Port A. Ports B and D are terminated in Z₀ while Port C is terminated in an unknown impedance, Z_c. As we observed in **Table VIII**, a 20 dB directional coupler splits a signal into two unequal components with the coupled output attenuated by 20 dB and the main line output attenuated by 0.04 dB. Thus the incident signal at Port A, V_{in}, is split into two components, V_{in} -20dB which is delivered to the Z₀ load at Port D and V_{in} -0.04 dB which appears at the unknown load Z_c at Port C. If Z_c is any value other than Z₀ part of the incident signal is reflected and appears back at Port C as V_{refl}. The magnitude of the return loss of Z_c can be determined knowing either Z_c or P_c (reflection coefficient) as follows:

$$P_c = \frac{Z_c - Z_0}{Z_c + Z_0}$$

$$\text{Return loss of } Z_c = 20 \log \frac{1}{|P_c|}$$

$$20 \log \left| \frac{Z_c + Z_0}{Z_c - Z_0} \right|$$

$$V_{\text{REFL}} = V_{\text{in}} - 0.04 \text{ dB} - \text{Return Loss of } Z_c$$

$$= V_{\text{in}} - 0.04 \text{ dB} - \log \left| \frac{Z_c + Z_0}{Z_c - Z_0} \right|$$

The signal V_{REFL} , which enters Port C, is in turn split with ($V_{REFL} - 20$ dB) appearing at the Z_o termination on Port B and ($V_{REFL} - 0.04$ dB) being dissipated in the source impedance, Z_o at Port A. If we compare signal levels at Ports D and B, we find the following:

$$V_D = V_{in} - 20 \text{ dB}$$

$$V_B = V_{REFL} - 20 \text{ dB}$$

or otherwise: $V_B = V_{in} - 20.04 \text{ dB} -$

Return Loss of Z_c

Thus we find that a comparison of signal levels at Ports B and D gives us a direct measure of the return loss or complex impedance of Z_c . In fact, the signal levels are offset only by the return loss and the small main line loss.

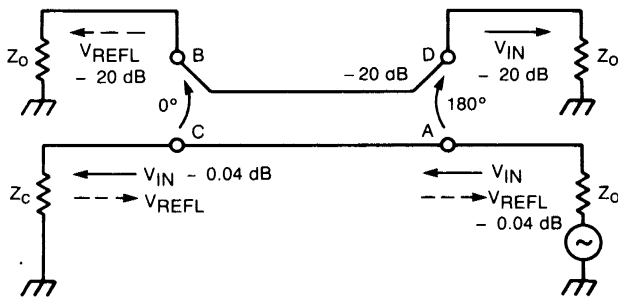

Figure 10. Incident and Reflected Signal Flow

We can also see that if $Z_c = Z_o$ that the return loss of Z_c becomes infinite and no signal will reach Port B. This, of course, should follow from the consideration that Ports A and B and ports C and D are isolated when the directional coupler is terminated in Z_o impedance loads. Practical directional couplers have finite isolation and this introduces an error in the comparative levels at Ports B and D.

Directional couplers are often used for measurements where an unknown mismatch is expected at one port as was illustrated in **Figure 10**. The directivity of the coupler is a limiting parameter in the ability to accurately measure the return loss of this unknown.

As an example, consider the coupler shown in **Figure 10**. We will assume the following parameters:

Isolation, A to B = 40 dB

Coupling, A to D or C to B = 20 dB

If we connect an unknown impedance which has an actual return loss of 20 dB, we observe that two equal amplitude signal components are present at Port B, the first, V_{INT} , due to internal mismatches and unbalance in the coupler as measured by the directivity and the second, V_{EXT} , due to reflection from the external unknown. For stated conditions:

$$|V_{INT}| = |V_{EXT}|$$

Since the relative phase of the complex voltages V_{INT} and V_{EXT} is unknown, the resultant voltage can vary over a wide range. Two extremes exist: in-phase and 180° out-of-phase.

1. In-Phase

$$V_{INT} = V_{EXT} = V$$

$$V_{RESULTANT} = V_{INT} + V_{EXT}$$

$$\text{Apparent Return Loss} =$$

$$\text{Actual Return Loss} - 6 \text{ dB}$$

2. 180° Out-Of-Phase

$$V_{INT} = V_{EXT}$$

$$V_{RESULTANT} = V_{INT} + (-V_{EXT}) = 0$$

$$\text{Apparent Return Loss} = \infty \text{ (infinity)}$$

The apparent return loss of the unknown can vary from 6 dB worse than the actual return loss to infinity or an apparent perfect match. As a rule-of-thumb the directivity of the coupler should be 20 dB greater than the return loss of the unknown load. This will keep directivity errors below 1 dB.

Performance Parameters

The parameters of frequency range, impedance and VSWR previously defined in the 3 dB hybrid section also apply to directional couplers. In addition, four new parameters are defined.

Coupling

This is the attenuation of a signal at the coupled port relative to the input signal level.

Coupling Flatness

This is the variation in coupling over the frequency range specified.

Directivity

This is the signal level at an isolated port relative to the signal level at a coupled port when the signal is injected at an input or to state it as S-parameters: $S_{BC} - S_{BA}$.

Main Line Loss

This is the total insertion loss in the main line.

Coupler Circuits

There are a variety of ways to construct directional couplers. As previously stated, the RF frequency devices are often constructed using wire wound ferrite cores to provide coupling. Many of M/A-COM's standard couplers, especially the microwave frequency devices, are constructed using stripline printed circuit techniques.

Single Section Couplers -- The simplest type of coupler circuit is the single section directional coupler. This type of coupler may be either the offset or overlap configurations shown in **Figure 11**.

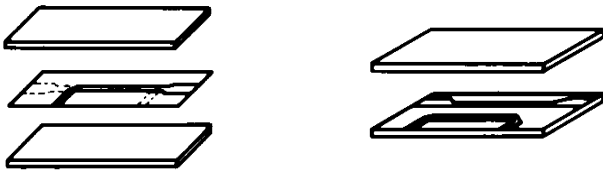

Figure 11

The offset coupler circuit is typically etched on a printed circuit board, over which is placed a blank dielectric board. The overlap coupler is usually etched on both sides of a thin sheet of dielectric material and sandwiched between sections of dielectric. Loosely coupled devices can also be realized with microstrip circuitry. The construction used is based on coupling, frequency and other requirements.

Generally, overlap couplers are used for coupling values from 3 to 10 dB; a 3 dB coupler is almost a complete overlap.

Multi Section Couplers -- Most octave bandwidth low frequency couplers up to 4 GHz are single section couplers. Multi-section couplers are used in place of single section couplers to increase the bandwidth and flatten out the frequency response. Some of the sections may be overlap couplers and some may be offset. Multi-section couplers may be either symmetric or asymmetric.

Asymmetric couplers may have any number of sections. For a given overall length they result in greater bandwidth and/or flatter frequency response than corresponding symmetric couplers. Two, three and four section asymmetric couplers are used in most mini and internally loaded couplers from 4 to 18 GHz.

Symmetric couplers must be an odd number of sections and usually are 1,3, or 5 sections (note that a single section coupler is symmetric). Symmetric couplers are quadrature and thus must be used for all 90° hybrids. Low frequency octave band hybrids up to 4 or 8 GHz are single section symmetric couplers. Three section symmetric couplers are used on higher frequency models.

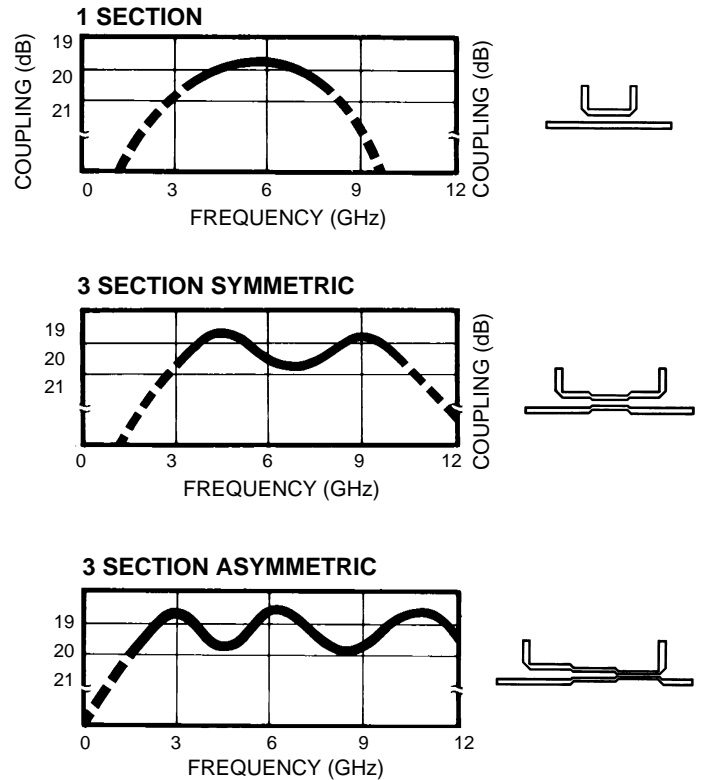

Figure 12: Single Section and Multi-section Directional Couplers

Shown, for comparison, are coupler circuits for single section, three section symmetric and three section asymmetric couplers together with their theoretical coupling curves. All couplers have their operating frequencies centered at 6 GHz (see **Figure 12**).

Tapered Line Couplers -- A tapered line coupler is a coupler in which the coupling varies continuously along the coupling region. Tapered line couplers usually are either symmetric or asymmetric as shown in **Figure 13**.

Symmetric tapered line couplers have theoretical coupling curves similar to the multi-section symmetric couplers after which they are patterned. They also have quadrature coupling like other symmetric couplers. They usually have better VSWR and directivity, but are most difficult to construct and require more room than symmetric stepped couplers. The (2032-6370-00) utilizes two symmetric tapered line couplers connected in tandem.

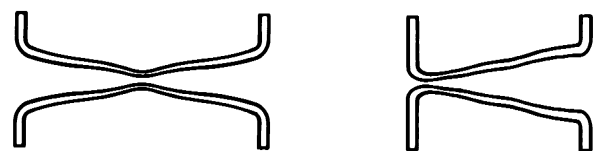

Figure 13 Tapered Line Couplers

Asymmetric tapered line couplers represent the ultimate for broad bandwidth. Since they are high pass coupler circuits, there is no theoretical limit to the upper frequency at which any asymmetrical coupler will function properly. Practical limits to the upper operational frequency include losses in the stripline circuit, moding in the coupler cavity and the VSWR of discontinuities in the circuit.

Tandem Couplers -- In many instances, especially in the design of very broadband 3 dB couplers, the previously mentioned couplers have some deficiencies. In such instances, these deficiencies may be overcome by using a tandem interconnection of couplers as shown in **Figure 14**.

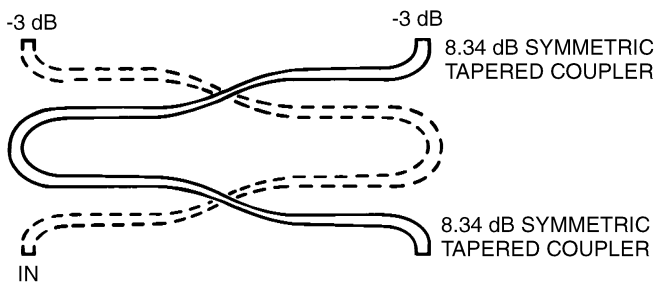
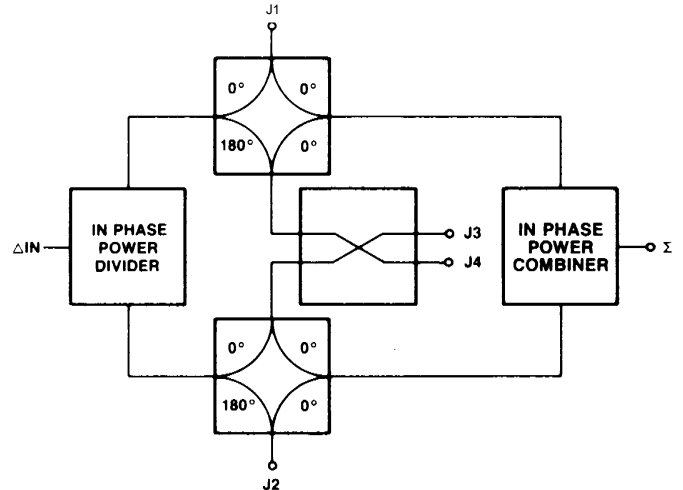

Figure 14 Tandem Coupler

Such a configuration was used in the design of the (2032-6370-00) 2 to 12.4 GHz hybrid. The hybrid consists of two tandemly connected 8.34 dB symmetric tapered line couplers. The end result is a 3 dB hybrid with ± 0.5 dB frequency sensitivity and typically 20 dB isolation from 2 to 12 GHz.

Integrated Hybrid Networks — M/A-COM offers a number of interconnected hybrid/coupler networks for beam forming networks, monopulse comparators, and other applications. Please see our product listings or consult the factory.



Navigation Guidance Beamformer

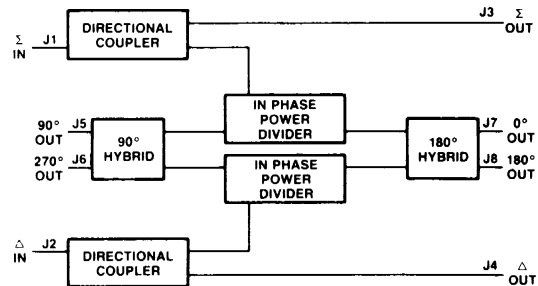

Airborne / Seeker Beamformer

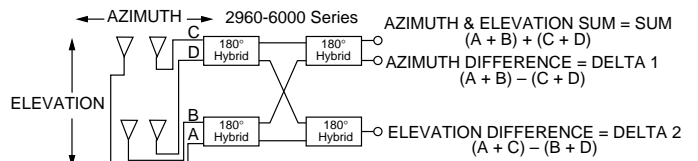

Monopulse Comparator Network

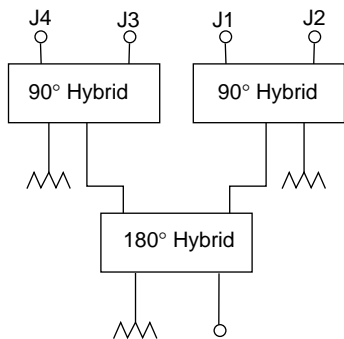

Quadrature Power Divider/Combiner