

APPLICATION NOTE

**Combining units for a 1 kW
wideband HF amplifier**

AN98032

Combining units for a 1 kW wideband HF amplifier

Application Note
AN98032

CONTENTS

- 1 SUMMARY
- 2 INTRODUCTION
- 3 CIRCUIT DESCRIPTION
 - 3.1 The input power divider
 - 3.2 The output power combiner
- 4 MEASURED RESULTS
- 5 PARTS LIST

1 SUMMARY

Based on Philips 4C6 ferrite toroids, input and output combining units are described for combining four 300 W PEP linear wideband amplifiers to produce at least 1 kW PEP in the HF band (1.6 – 30 MHz) with an intermodulation distortion of less than –30 dB.

2 INTRODUCTION

For long-range communication, the HF band from 1.6 – 30 MHz is used. As the modulation method is mainly SSB, linear amplifiers are required with output powers of 1 kW PEP in many cases. However, the best power amplifiers obtainable only have output powers of 300 to 400 W PEP. For example, Report AN98030 describes a push-pull amplifier using two BLW96 bipolar transistors delivering 400 W PEP, while Report NCO8703 describes a push-pull amplifier using two BLF177 MOS transistors delivering 300 W PEP. So four of these amplifiers are required to achieve powers of 1 kW PEP.

This report describes suitable combining units for both the input and output of such amplifiers to achieve the power mentioned above.

3 CIRCUIT DESCRIPTION

All transformers and hybrids used in the combiners are transmission line types as described in report ECO6907. Extensive use is made of Ferroxcube toroids, size: $36 \times 23 \times 15 \text{ mm}^3$, material: 4C6. Part no.: 4322 020 91090.

3.1 The input power divider

Figs 1 and 2 show the block diagram and circuit diagram of the divider. It consists of four transformers wound on ferrite toroids, each transformer using one 4C6 toroid.

The input transformer provides a 4:1 impedance transformation from 50 Ω unbalanced input to 12.5 Ω unbalanced output. It consists of 7 turns of two parallel 50 Ω cables (3 mm ext. dia.) wound on the toroid.

The second transformer consists of 7 turns of two parallel 50 Ω cables (3 mm ext. dia.) wound on one toroid with the connections arranged as a hybrid to give a transformation from 12.5 Ω to two 25 Ω unbalanced in-phase outputs.

The third and fourth transformers are identical and consist of 8 turns of 50 Ω coaxial cable (3 mm ext. dia.) wound on the toroid with the connections arranged as a hybrid to give a transformation from 25 Ω to two 50 Ω unbalanced in-phase outputs.

Out-of-balance (or power dumping) resistors of 100 Ω are connected across the two 50 Ω output ports of each output transformer, and a 50 Ω resistor is connected across the two 25 Ω output ports of the intermediate hybrid transformer.

Although ideal transmission line transformers operate over a very wide band, in practice, there are inevitable performance degradations due to stray capacitance, stray leakage inductances etc. caused by the construction of such a system. In addition, the relatively large ballast resistors and their connecting leads (stray inductances) must be compensated by capacitors to obtain a near constant impedance throughout the band (1.6 – 30 MHz).

It was found experimentally, using a Hewlett Packard vector impedance meter, that satisfactory impedance compensation could be obtained by using three capacitors (120 pF, 80 pF and 80 pF) connected between the 12.5 Ω terminal and earth and each of the two 25 Ω impedance terminals to earth. The final result gave a maximum VSWR of 1.3 at the input port with all other ports terminated with 50 Ω wideband loads. Figure 3 shows the measured VSWR throughout the band.

The rating of the hybrid resistors is sufficient for fail-safe operation of the system under the worst fault conditions for continuous CW operation without forced air cooling of the resistors.

3.2 The output power combiner

Figs 4 and 5 show the block diagram and a circuit diagram of the combiner. Like the input power divider, it consists of four transformers wound on ferrite toroids.

One pair of amplifiers is coupled through 50 Ω ports to a common 25 Ω port (as is the other pair). Each transformer is wound with 5 turns of PTFE dielectric coaxial cable (2.5 mm ext. dia.) on a stacked core of two toroids, the connections arranged as a hybrid transformer from 50 Ω plus 50 Ω to 25 Ω . Out-of-balance (or power dumping) resistors of 100 Ω are connected across the two 50 Ω ports of each hybrid transformer.

A third hybrid transformer couples the two 25 Ω outputs to combine the power from these two sources to an impedance of 12.5 Ω . This transformer is wound with 3 turns of two 50 Ω PTFE dielectric coaxial cables (4.0 mm ext. dia.) on a stack of four toroids, the connections being arranged as a hybrid transformer from 25 Ω plus 25 Ω to 12.5 Ω . An out-of-balance (or power dumping) resistor of 50 Ω is connected across the two 25 Ω inputs.

The fourth transformer is a 1:4 impedance transformer which transforms the combined output at 12.5 Ω impedance to the 50 Ω load impedance. This transformer is wound with 4 turns of two parallel 50 Ω PTFE dielectric coaxial cables (4.0 mm ext. dia.) on a stack of five toroids, the connections are arranged for a 1:4 impedance transformer (unbalanced).

To compensate the stray influences (leakage inductance and capacitance etc.) it was found experimentally, using a vector impedance meter, that satisfactory compensation could be obtained using five capacitors connected at the points shown in the circuit of Fig.5. The final result (Fig.6) shows a maximum VSWR of 1.16 on any input port with all other ports terminated with 50 Ω wideband loads.

The rating of the hybrid resistors is sufficient for short-term fault conditions with two-tone signals without forced air cooling. With suitable forced air cooling, continuous CW operation under the most severe fault condition (two units inoperative) is possible.

A parts list for the input and output combiner units is given in Chapter 5.

4 MEASURED RESULTS

The practical performance of the units described was tested with four push-pull amplifiers each using two BLX15 bipolar transistors. The results concerning intermodulation are shown in the graphs of Fig.7 for a total output power of 1 kW PEP. All intermodulation products remained below -30 dB. Note, the BLX15 is no longer in Philips' product program and has been superseded by the BLW96 which has a maximum output power of 200 W PEP (at $d_3 \leq -30$ dB).

To keep the power loss in the hybrid resistors as low as possible, it is desirable to use amplifiers having roughly the same power gain. In the case of bipolar transistors, eight devices should be chosen from the same h_{FE} group, while for MOS transistors, devices should be chosen from the same $V_{GS(th)}$ group.

Combining units for a 1 kW wideband HF amplifier

Application Note
AN98032

5 PARTS LIST

Table 1 Input power divider

4	4C6 Ferroxcube toroids (Philips); 36 × 23 × 15 mm; part no.: 4322 020 91090
1	50 Ω resistor, Electrosil type H35, 30 W
2	100 Ω resistor, Electrosil type H33, 15 W
	Miniature 50 Ω coaxial cable windings; external dia. approx. 3 mm (from any suitable manufacturer)
2	82 pF tubular ceramic (or ceramic plate) capacitors (low ε _r)
1	120 pF tubular ceramic (or ceramic plate) capacitor (low ε _r)

Table 2 Output power combiner

13	4C6 Ferroxcube toroids (Philips); 36 × 23 × 15 mm; part no.: 4322 020 91090
2	100 Ω resistors in parallel, Electrosil type H37
2	100 Ω resistors, Electrosil type H37
	50 Ω PTFE dielectric insulated coaxial cable; external dia. approx. 4 mm (from any suitable manufacturer)
2	33 pF ceramic block capacitors (ATC)
2	68 pF ceramic block capacitors (ATC)
1	120 pF ceramic block capacitors (ATC)

Combining units for a 1 kW wideband
HF amplifier

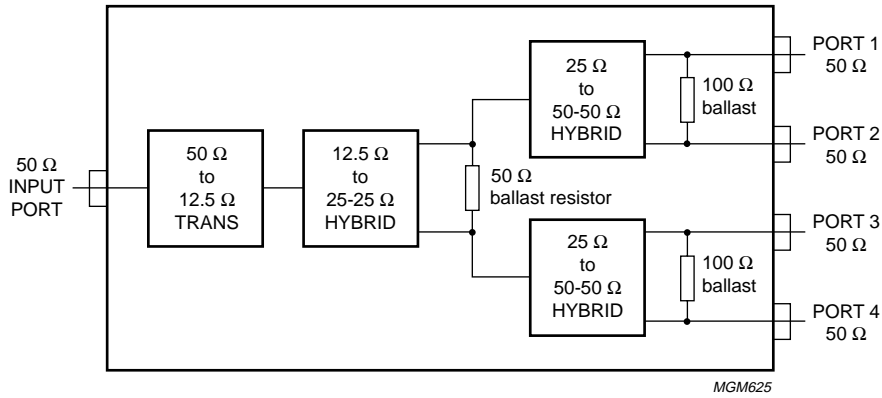

Fig.1 Block schematic of the input power divider.

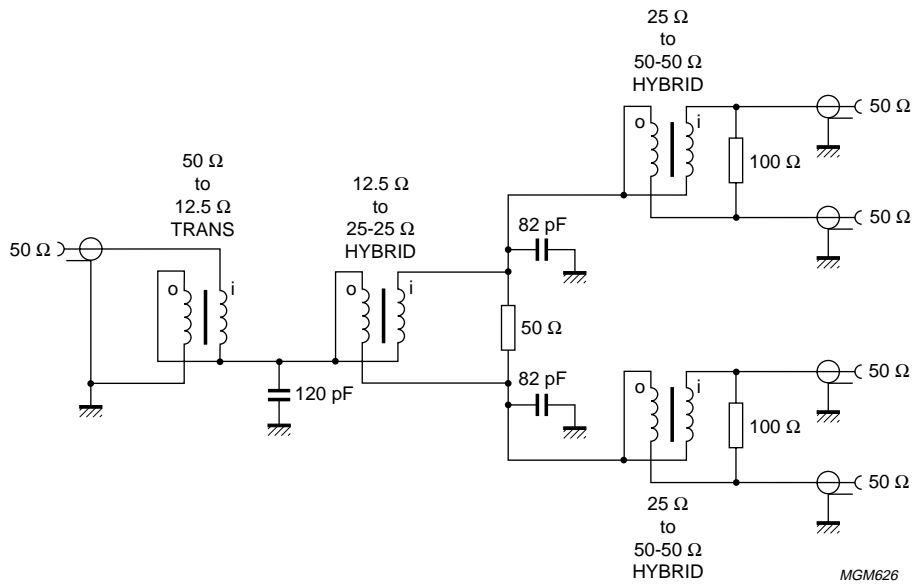

Fig.2 Circuit diagram of the input power divider.

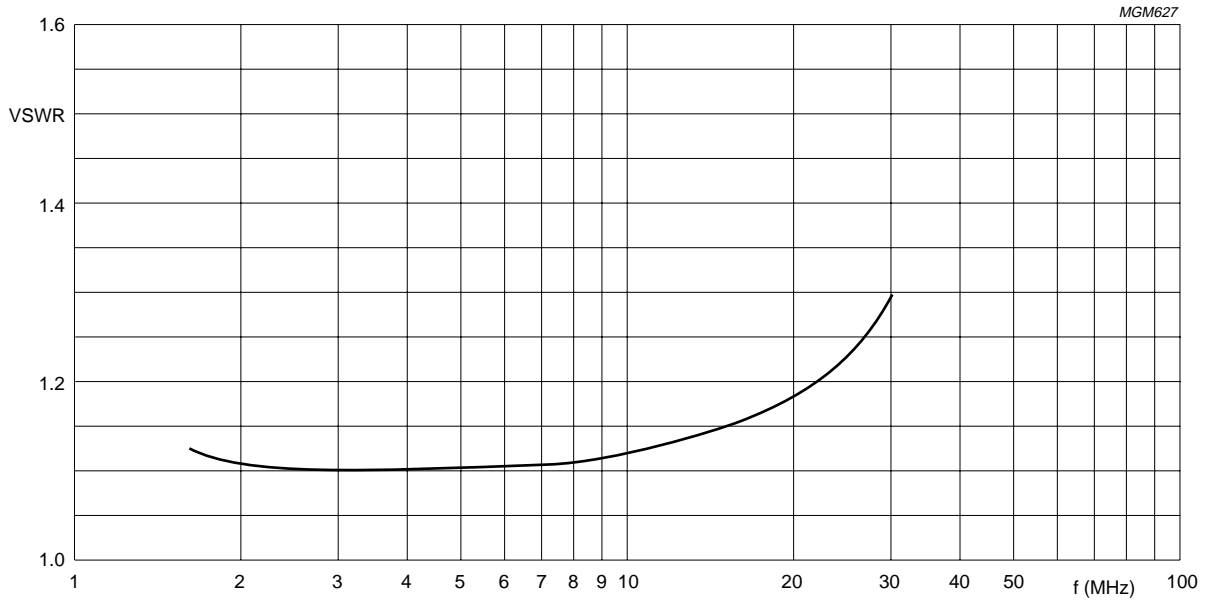

Fig.3 Input VSWR of the hybrid coupler with all output ports loaded by 50 Ω .

Combining units for a 1 kW wideband HF amplifier

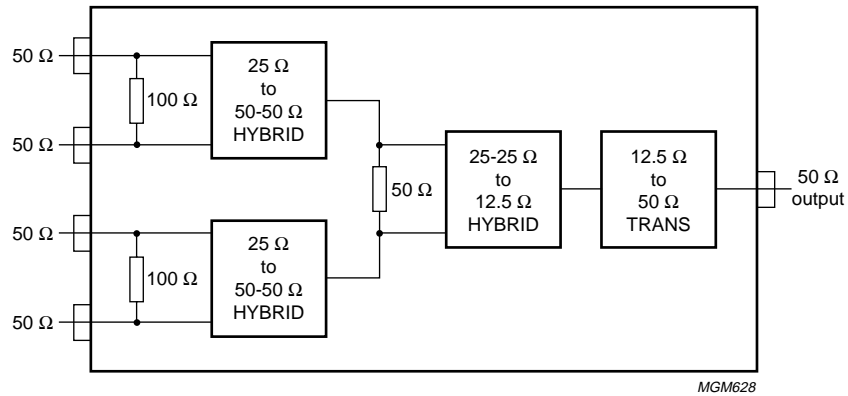

Fig.4 Block schematic of the output power combiner.

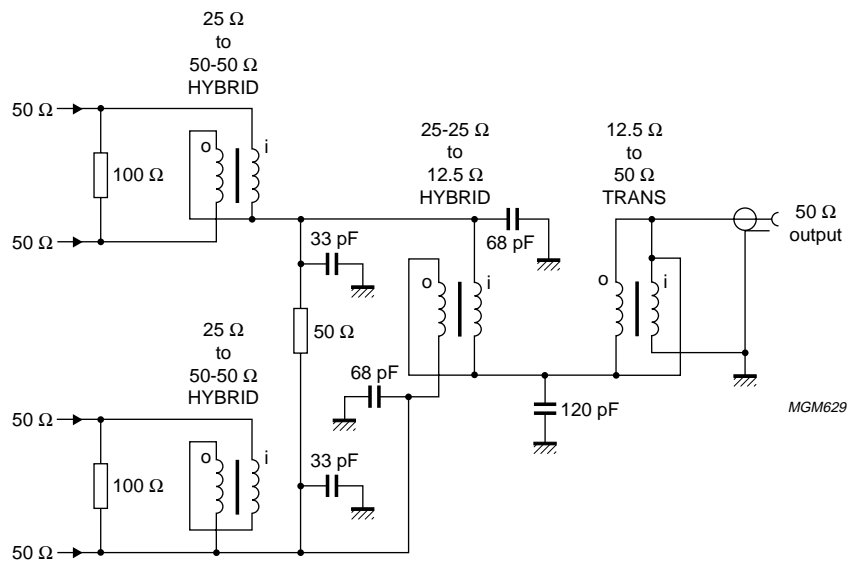

Fig.5 Circuit diagram of the output power combiner.

Combining units for a 1 kW wideband
HF amplifier

Application Note
AN98032

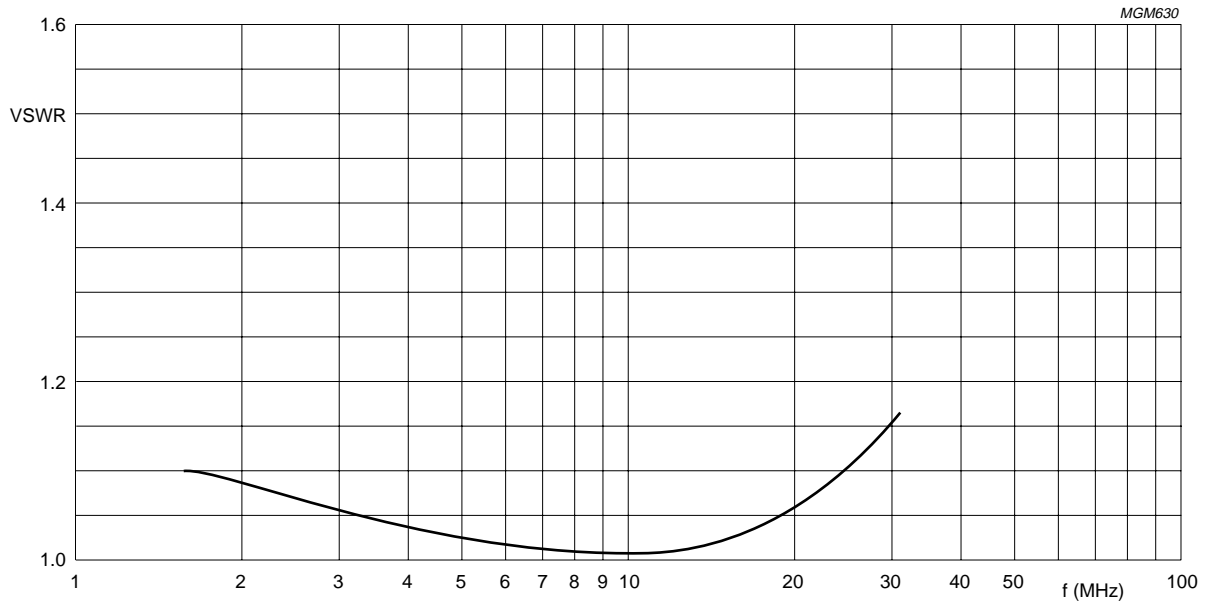

Fig.6 VSWR of any 50 Ω input port with all other ports terminated by 50 Ω .

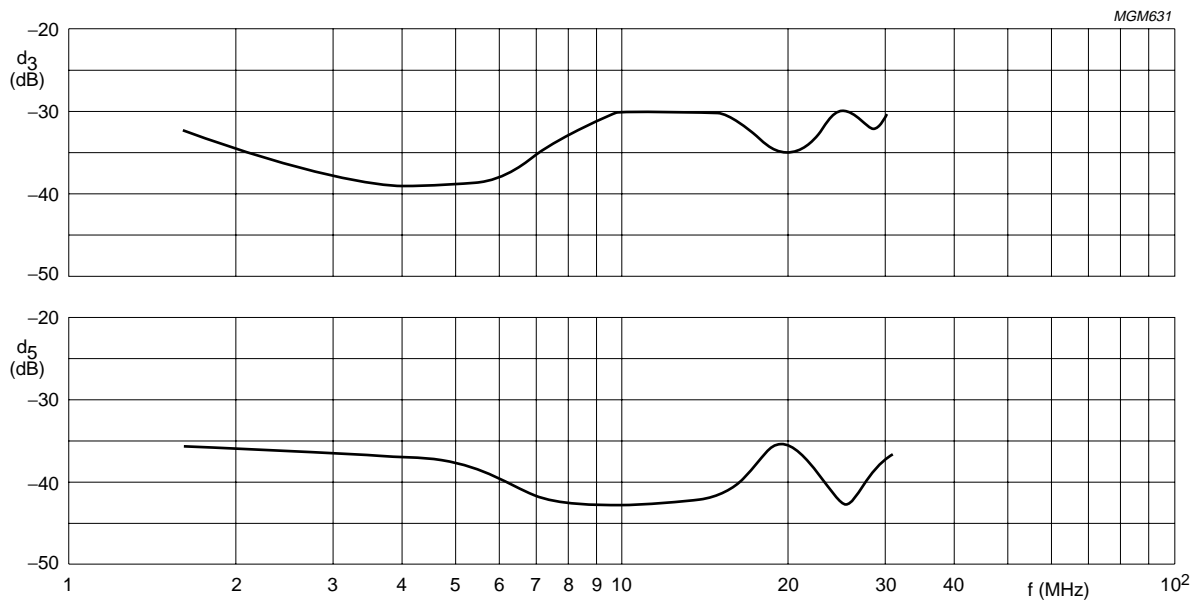

Fig.7 Intermodulation distortion (d_3 and d_5) of the four 300 W amplifiers coupled with hybrid couplers and driven to 1 kW PEP.

Philips Semiconductors – a worldwide company

Argentina: see South America

Australia: 34 Waterloo Road, NORTH RYDE, NSW 2113,
Tel. +61 2 9805 4455, Fax. +61 2 9805 4466

Austria: Computerstr. 6, A-1101 WIEN, P.O. Box 213, Tel. +43 160 1010,
Fax. +43 160 101 1210

Belarus: Hotel Minsk Business Center, Bld. 3, r. 1211, Volodarski Str. 6,
220050 MINSK, Tel. +375 172 200 733, Fax. +375 172 200 773

Belgium: see The Netherlands

Brazil: see South America

Bulgaria: Philips Bulgaria Ltd., Energoproject, 15th floor,
51 James Bourchier Blvd., 1407 SOFIA,
Tel. +359 2 689 211, Fax. +359 2 689 102

Canada: PHILIPS SEMICONDUCTORS/COMPONENTS,
Tel. +1 800 234 7381

China/Hong Kong: 501 Hong Kong Industrial Technology Centre,
72 Tat Chee Avenue, Kowloon Tong, HONG KONG,
Tel. +852 2319 7888, Fax. +852 2319 7700

Colombia: see South America

Czech Republic: see Austria

Denmark: Prags Boulevard 80, PB 1919, DK-2300 COPENHAGEN S,
Tel. +45 32 88 2636, Fax. +45 31 57 0044

Finland: Sinikalliontie 3, FIN-02630 ESPOO,
Tel. +358 9 615800, Fax. +358 9 61580920

France: 51 Rue Carnot, BP317, 92156 SURESNES Cedex,
Tel. +33 1 40 99 6161, Fax. +33 1 40 99 6427

Germany: Hammerbrookstraße 69, D-20097 HAMBURG,
Tel. +49 40 23 53 60, Fax. +49 40 23 536 300

Greece: No. 15, 25th March Street, GR 17778 TAVROS/ATHENS,
Tel. +30 1 4894 339/239, Fax. +30 1 4814 240

Hungary: see Austria

India: Philips INDIA Ltd, Band Box Building, 2nd floor,
254-D, Dr. Annie Besant Road, Worli, MUMBAI 400 025,
Tel. +91 22 493 8541, Fax. +91 22 493 0966

Indonesia: see Singapore

Ireland: Newstead, Clonskeagh, DUBLIN 14,
Tel. +353 1 7640 000, Fax. +353 1 7640 200

Israel: RAPAC Electronics, 7 Kehilat Saloniki St, PO Box 18053,
TEL AVIV 61180, Tel. +972 3 645 0444, Fax. +972 3 649 1007

Italy: PHILIPS SEMICONDUCTORS, Piazza IV Novembre 3,
20124 MILANO, Tel. +39 2 6752 2531, Fax. +39 2 6752 2557

Japan: Philips Bldg 13-37, Kohnan 2-chome, Minato-ku, TOKYO 108,
Tel. +81 3 3740 5130, Fax. +81 3 3740 5077

Korea: Philips House, 260-199 Itaewon-dong, Yongsan-ku, SEOUL,
Tel. +82 2 709 1412, Fax. +82 2 709 1415

Malaysia: No. 76 Jalan Universiti, 46200 PETALING JAYA, SELANGOR,
Tel. +60 3 750 5214, Fax. +60 3 757 4880

Mexico: 5900 Gateway East, Suite 200, EL PASO, TEXAS 79905,
Tel. +9-5 800 234 7381

Middle East: see Italy

Netherlands: Postbus 90050, 5600 PB EINDHOVEN, Bldg. VB,
Tel. +31 40 27 82785, Fax. +31 40 27 88399

New Zealand: 2 Wagener Place, C.P.O. Box 1041, AUCKLAND,
Tel. +64 9 849 4160, Fax. +64 9 849 7811

Norway: Box 1, Manglerud 0612, OSLO,
Tel. +47 22 74 8000, Fax. +47 22 74 8341

Philippines: Philips Semiconductors Philippines Inc.,
106 Valero St. Salcedo Village, P.O. Box 2108 MCC, MAKATI,
Metro MANILA, Tel. +63 2 816 6380, Fax. +63 2 817 3474

Poland: Ul. Lukiska 10, PL 04-123 WARSZAWA,
Tel. +48 22 612 2831, Fax. +48 22 612 2327

Portugal: see Spain

Romania: see Italy

Russia: Philips Russia, Ul. Usatcheva 35A, 119048 MOSCOW,
Tel. +7 095 755 6918, Fax. +7 095 755 6919

Singapore: Lorong 1, Toa Payoh, SINGAPORE 1231,
Tel. +65 350 2538, Fax. +65 251 6500

Slovakia: see Austria

Slovenia: see Italy

South Africa: S.A. PHILIPS Pty Ltd., 195-215 Main Road Martindale,
2092 JOHANNESBURG, P.O. Box 7430 Johannesburg 2000,
Tel. +27 11 470 5911, Fax. +27 11 470 5494

South America: Al. Vicente Pinzon, 173, 6th floor,
04547-130 SÃO PAULO, SP, Brazil,
Tel. +55 11 821 2333, Fax. +55 11 821 2382

Spain: Balmes 22, 08007 BARCELONA,
Tel. +34 3 301 6312, Fax. +34 3 301 4107

Sweden: Kottbygatan 7, Akalla, S-16485 STOCKHOLM,
Tel. +46 8 632 2000, Fax. +46 8 632 2745

Switzerland: Allmendstrasse 140, CH-8027 ZÜRICH,
Tel. +41 1 488 2686, Fax. +41 1 488 3263

Taiwan: Philips Semiconductors, 6F, No. 96, Chien Kuo N. Rd., Sec. 1,
TAIPEI, Taiwan Tel. +886 2 2134 2865, Fax. +886 2 2134 2874

Thailand: PHILIPS ELECTRONICS (THAILAND) Ltd.,
209/2 Sanpavuth-Bangna Road Prakanong, BANGKOK 10260,
Tel. +66 2 745 4090, Fax. +66 2 398 0793

Turkey: Talatpasa Cad. No. 5, 80640 GÜLTEPE/ISTANBUL,
Tel. +90 212 279 2770, Fax. +90 212 282 6707

Ukraine: PHILIPS UKRAINE, 4 Patrice Lumumba str., Building B, Floor 7,
252042 KIEV, Tel. +380 44 264 2776, Fax. +380 44 268 0461

United Kingdom: Philips Semiconductors Ltd., 276 Bath Road, Hayes,
MIDDLESEX UB3 5BX, Tel. +44 181 730 5000, Fax. +44 181 754 8421

United States: 811 East Arques Avenue, SUNNYVALE, CA 94088-3409,
Tel. +1 800 234 7381

Uruguay: see South America

Vietnam: see Singapore

Yugoslavia: PHILIPS, Trg N. Pasica 5/v, 11000 BEOGRAD,
Tel. +381 11 625 344, Fax. +381 11 635 777

For all other countries apply to: Philips Semiconductors,
International Marketing & Sales Communications, Building BE-p, P.O. Box 218,
5600 MD EINDHOVEN, The Netherlands, Fax. +31 40 27 24825

Internet: <http://www.semiconductors.philips.com>

© Philips Electronics N.V. 1998

SCA57

All rights are reserved. Reproduction in whole or in part is prohibited without the prior written consent of the copyright owner.

The information presented in this document does not form part of any quotation or contract, is believed to be accurate and reliable and may be changed without notice. No liability will be accepted by the publisher for any consequence of its use. Publication thereof does not convey nor imply any license under patent- or other industrial or intellectual property rights.

Printed in The Netherlands

Date of release: 1998 Mar 23

Let's make things better.

**Philips
Semiconductors**



PHILIPS

SUNSTAR 商斯达实业集团是集研发、生产、工程、销售、代理经销、技术咨询、信息服务等为一体的高科技企业，是专业高科技电子产品生产厂家，是具有 10 多年历史的专业电子元器件供应商，是中国最早和最大的仓储式连锁规模经营大型综合电子零部件代理分销商之一，是一家专业代理和分销世界各大品牌 IC 芯片和电子元器件的连锁经营综合性国际公司，专业经营进口、国产名厂名牌电子元件，型号、种类齐全。在香港、北京、深圳、上海、西安、成都等全国主要电子市场设有直属分公司和产品展示展销窗口门市部专卖店及代理分销商，已在全国范围内建成强大统一的供货和代理分销网络。我们专业代理经销、开发生产电子元器件、集成电路、传感器、微波光电元器件、工控机/DOC/DOM 电子盘、专用电路、单片机开发、MCU/DSP/ARM/FPGA 软件硬件、二极管、三极管、模块等，是您可靠的一站式现货配套供应商、方案提供商、部件功能模块开发配套商。商斯达实业公司拥有庞大的资料库，有数位毕业于著名高校——有中国电子工业摇篮之称的西安电子科技大学（西军电）并长期从事国防尖端科技研究的高级工程师为您精挑细选、量身订做各种高科技电子元器件，并解决各种技术问题。

微波光电部专业代理经销高频、微波、光纤、光电元器件、组件、部件、模块、整机；电磁兼容元器件、材料、设备；微波 CAD、EDA 软件、开发测试仿真工具；微波、光纤仪器仪表。欢迎国外高科技微波、光纤厂商将优秀产品介绍到中国、共同开拓市场。长期大量现货专业批发高频、微波、卫星、光纤、电视、CATV 器件：晶振、VCO、连接器、PIN 开关、变容二极管、开关二极管、低噪晶体管、功率电阻及电容、放大器、功率管、MMIC、混频器、耦合器、功分器、振荡器、合成器、衰减器、滤波器、隔离器、环行器、移相器、调制解调器；光电子元件和组件：红外发射管、红外接收管、光电开关、光敏管、发光二极管和发光二极管组件、半导体激光二极管和激光器组件、光电探测器和光接收组件、光发射接收模块、光纤激光器和光放大器、光调制器、光开关、DWDM 用光发射和接收器件、用户接入系统光收发器件与模块、光纤连接器、光纤跳线/尾纤、光衰减器、光纤适配器、光隔离器、光耦合器、光环行器、光复用器/转换器；无线收发芯片和模组、蓝牙芯片和模组。

更多产品请看本公司产品专用销售网站：

商斯达中国传感器科技信息网：<http://www.sensor-ic.com/>

商斯达工控安防网：<http://www.pc-ps.net/>

商斯达电子元器件网：<http://www.sunstare.com/>

商斯达微波光电产品网：[HTTP://www.rfoe.net/](http://www.rfoe.net/)

商斯达消费电子产品网：<http://www.icasic.com/>

商斯达实业科技产品网：<http://www.sunstars.cn/> 微波元器件销售热线：

地址：深圳市福田区福华路福庆街鸿图大厦 1602 室

电话：0755-82884100 83397033 83396822 83398585

传真：0755-83376182 (0) 13823648918 MSN: SUNS8888@hotmail.com

邮编：518033 E-mail:szss20@163.com QQ: 195847376

深圳赛格展销部：深圳华强北路赛格电子市场 2583 号 电话：0755-83665529 25059422

技术支持：0755-83394033 13501568376

欢迎索取免费详细资料、设计指南和光盘；产品凡多，未能尽录，欢迎来电查询。

北京分公司：北京海淀区知春路 132 号中发电子大厦 3097 号

TEL: 010-81159046 82615020 13501189838 FAX: 010-62543996

上海分公司：上海市北京东路 668 号上海赛格电子市场 D125 号

TEL: 021-28311762 56703037 13701955389 FAX: 021-56703037

西安分公司：西安高新开发区 20 所(中国电子科技集团导航技术研究所)

西安劳动南路 88 号电子商城二楼 D23 号

TEL: 029-81022619 13072977981 FAX:029-88789382