



PCD3316

Caller-ID on Call Waiting (CIDCW) receiver

11 March 1999

Product specification

1. General description

The PCD3316 is a low power mixed signal CMOS integrated circuit for receiving physical layer signals like Bellcore's 'CPE¹ Alerting Signal (CAS)' and the signals used in similar services. The device is capable of a very high precision detection of the dual tone (2130 and 2750 Hz) by using a patented digital algorithm. The PCD3316 can be used for on-hook and off-hook Caller-ID (CID), Caller-ID on Call Waiting (CIDCW) and Caller-Name (CNAM) applications.

For timing purposes the PCD3316 can be programmed to generate an interrupt signal to the microcontroller every second or every minute. These timings are derived from an on-chip 32.768 kHz oscillator.

Also incorporated in the device are a Frequency Shift Keying (FSK) receiver/demodulator and a 'Ring or polarity change detector'. The status of the PCD3316, the received FSK data bytes and the ringer period can be read and many options can be selected via the I²C-bus serial interface. Two on-chip oscillators are available. One 3.58 MHz oscillator for all internal functions and a low frequency 32.768 kHz oscillator for the 1 second or 1 minute timing.

In Power-down mode only the polarity comparators and the 32.768 kHz oscillator are active. The CAS detection, the FSK receiver and the 3.58 MHz oscillator can be enabled separately. Detection of a polarity change on the inputs POL0 or POL1, the reception of an FSK data byte, the detection of a CAS tone or a timebase interrupt is signalled to the microcontroller by an interrupt request signal (IRQ). The microcontroller can communicate with the PCD3316 device via the serial interface.

The PCD3316 is designed for use in a microcontroller controlled system. The device is available in a SO16 package.

A demonstration board OM5843 and an application note AN98071 are available.

1. CPE = Customer Premises Equipment.



PHILIPS

2. Features

- Bellcore's 'CPE Alerting Signal (CAS)' and British Telecom's (BT) 'Loop State Tone Alert Signal' detection
- BT's 'Idle State Tone Alert Signal' by means of monitoring the input signal level
- 1200 baud FSK demodulator conform Bell 202 and CCITT V23 standards
- Ring or polarity change detector
- Ring period measurement
- Low battery comparator
- Signal level detector
- On-hook and off-hook applications according to *Bellcore TR-NWT-000030* and *SR-TSV-002476* specifications
- Receive sensitivity of -37.8 dBm (in 600Ω) for CAS
- 2.5 to 3.6 V supply; low power standby mode
- Selectable 1 second or 1 minute timebase interrupt
- 3.58 MHz and 32.768 kHz crystal oscillators
- SO16 package.

3. Applications

- Analog Display Services Interface (ADSI) phones
- Feature phones and adjunct boxes with Bellcore CID, CIDCW and CNAM systems
- Computer Telephony Integrated (CTI) systems.

4. Ordering information

Table 1: Ordering information

Type number	Package		
	Name	Description	Version
PCD3316T	SO16	plastic small outline package; 16 leads; body width 7.5 mm	SOT162-1

5. Block diagram

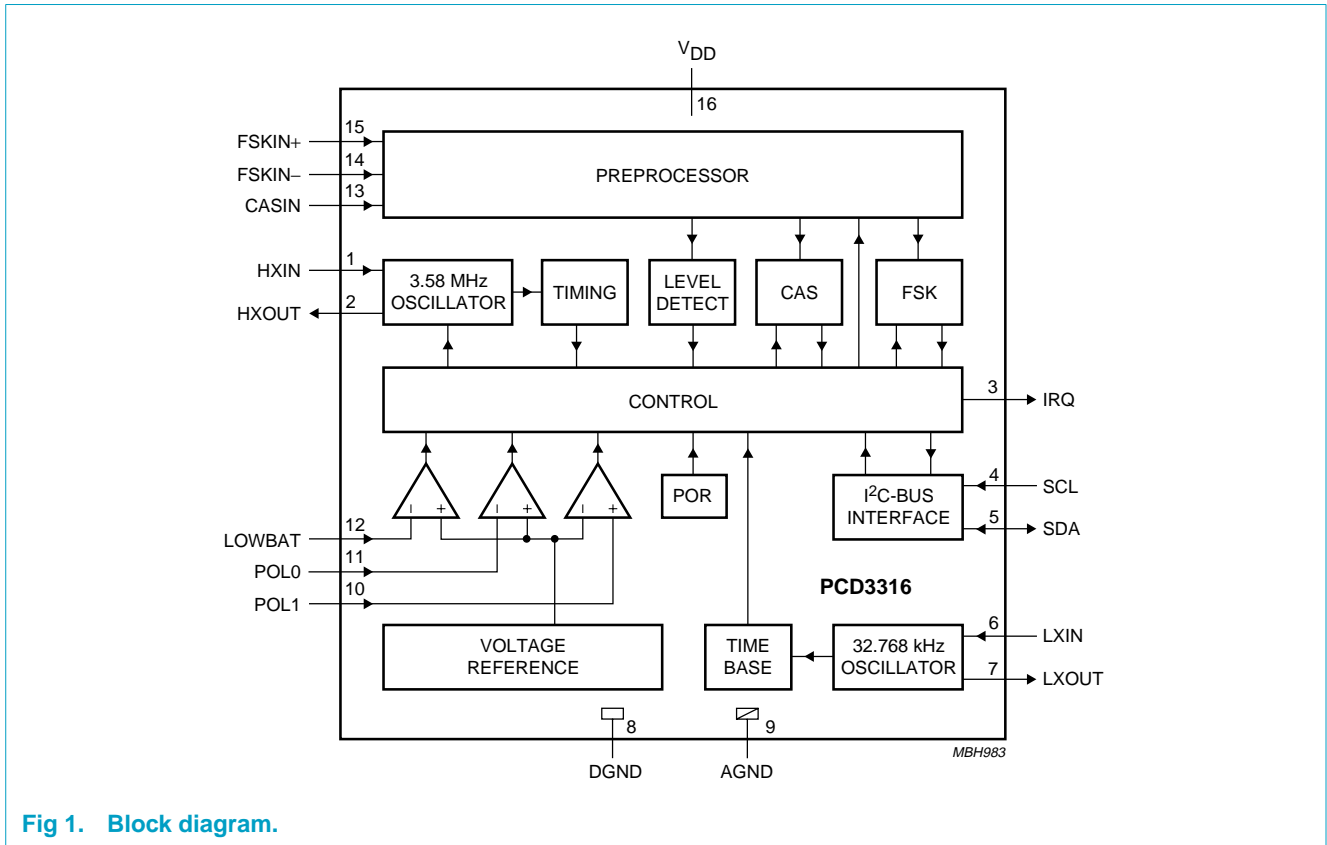

Fig 1. Block diagram.

6. Pinning information

6.1 Pinning

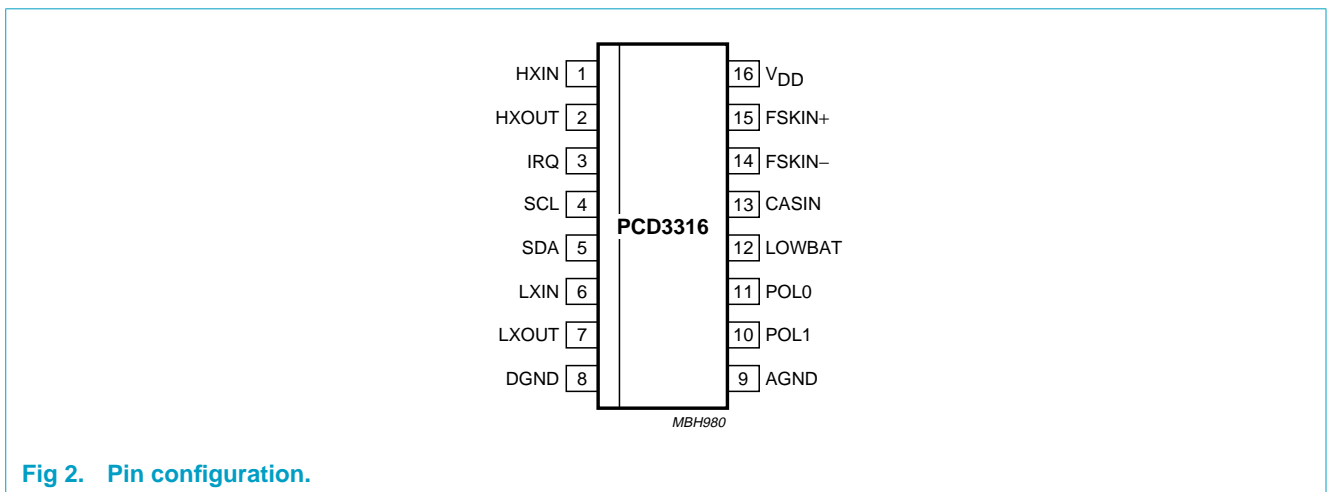

Fig 2. Pin configuration.

6.2 Pin description

Table 2: Pin description

Symbol	Pin	I/O	Description
HXIN	1	I	3.58 MHz crystal oscillator input
HXOUT	2	O	3.58 MHz crystal oscillator output
IRQ	3	O	interrupt output; programmable active HIGH or active LOW
SCL	4	I	serial clock line of I ² C-bus
SDA	5	I/O	serial data line of I ² C-bus
LXIN	6	I	32.768 kHz crystal oscillator input
LXOUT	7	O	32.768 kHz crystal oscillator output
DGND	8	–	digital ground
AGND	9	–	analog ground
POL1	10	I	polarity detector input 1
POL0	11	I	polarity detector input 0
LOWBAT	12	I	low battery detector input
CASIN	13	I	input pin for CAS signal
FSKIN–	14	I	negative input for FSK signal
FSKIN+	15	I	positive input for FSK signal
V _{DD}	16	–	supply

7. Functional description

7.1 Preprocessor and analog inputs

The preprocessor for the CAS detection and the FSK receiver incorporates an Analog-to-Digital Converter (ADC) and a digital bandpass filter.

The LOWBAT input of the PCD3316 can be used for low battery detection. The voltage on the LOWBAT pin is compared with an internal voltage reference circuit. When the LOWBAT voltage drops below the reference voltage, the Status register, bit 5 is set to logic 1.

The PCD3316 can be forced in a Power-down state by switching off the 3.58 MHz system clock and the ADC. This is done by setting Mode register 2, bit 7 (CIDMD2.7) to logic 0. To guarantee correct operation the following order of actions must be performed (see also [Section 7.8](#) about interrupts):

1. Switch off CAS and FSK detection (if turned on)
2. Read the interrupt register (thus clearing pending interrupts generated by the CAS and FSK detector)
3. Switch off the 3.58 MHz oscillator by clearing bit 7 of Mode register 2.

The two low power comparators (inputs POL0 and POL1) and the 32.768 kHz clock are always active.

They can be used for ring or line polarity reversal detection. The POL on/off bit (Mode register 1, bit 4) must be set to enable generation of an interrupt when a polarity change occurs. The result of the two comparators can be read in bits 7 and 6 (POL0 and POL1) of the Status register (see [Section 7.4](#)). The 3.58 MHz clock is not needed for the generation of a polarity interrupt.

7.2 CAS detection

After a power-on reset or after enabling the CAS detector the internal registers of the CAS detection function are initialized. The initialization takes a maximum of 100 periods of the 3.58 MHz clock.

If the CAS detection is enabled the PCD3316 will generate an interrupt (Interrupt register, bit 1 is set) when a correct dual tone (2130 and 2750 Hz) is detected. Interrupts will be blocked when the signal level on the CAS input is below the threshold in the level detector.

7.3 FSK reception

The FSK receiver function can be enabled by setting the FSK on/off bit (Mode register 1, bit 7).

In the FSK transmission specification of BT and Bellcore a channel seizure is transmitted first (sequence of 1010..). After the channel seizure a block of marks and finally the data pattern are sent (see [Figure 3](#)). These mark bits are detected by the PCD3316 which sets the FSK-BOM Indication bit (Status register, bit 4). The FSK-BOM Indication bit is reset when the FSK receiver is disabled.

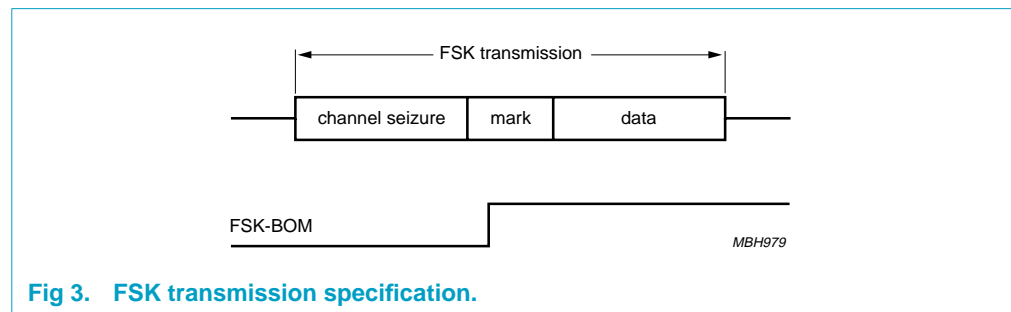

Fig 3. FSK transmission specification.

If the FSK-BOM Indication bit is set, the FSK receiver will generate an interrupt after it has received a complete data word. An FSK data word consists of one start bit (space), followed by eight data bits and one stop bit (mark). Interrupts will therefore not be generated during the channel seizure and during the block of marks. When a valid data word has been received, FSK data is available in the FSK data register.

By clearing the FSK-BOM-mask on/off bit (Mode register 1, bit 6), the FSK receiver will not wait with the generation of interrupts until a Begin Of Mark (BOM) has been detected but will handle the channel seizure as normal data. The block of marks which is a string of logic 1 will still not generate interrupts because there are no start bits.

After the generation of an interrupt the IRQ pin will become active (see [Figure 4](#)), and the FSK Interrupt bit is set (Interrupt register, bit 5). The received data is available in the FSK data register.

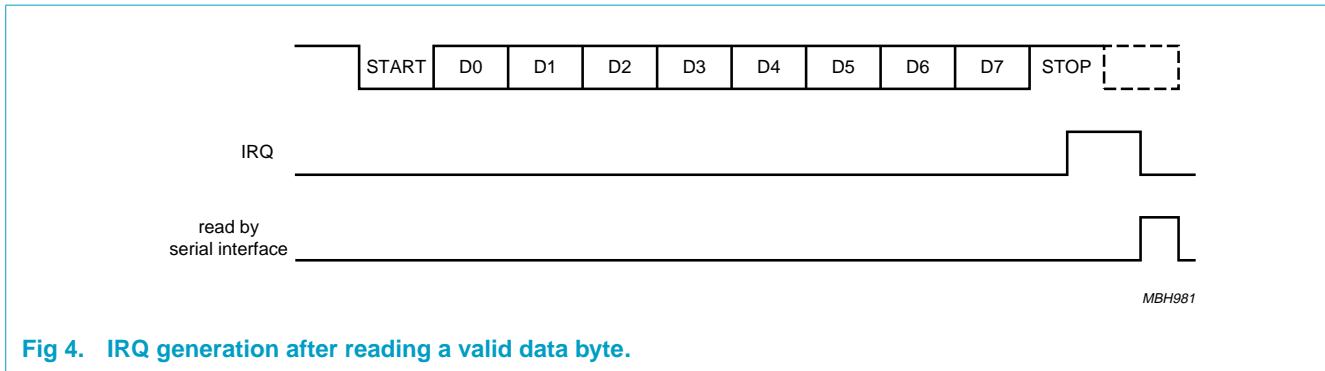

Fig 4. IRQ generation after reading a valid data byte.

The FSK-OVR Error bit (Status register, bit 3) indicates that a previous byte is lost due to an overrun. The FSK-FRM Error bit (Status register, bit 2) indicates an incorrect start- or stop-bit. These frame errors indicate that there are synchronization problems. The on-chip level detector can be used to detect a carrier loss during FSK transmission. FSK data can be rejected when the signal level is below the reference level, this to avoid that noise is interpreted as data (Interrupt register, bit 4 is logic 1).

7.4 Ring or polarity change detector

For ring and polarity change detection two comparators are available in the PCD3316. The reference level of the comparators is set internally by the reference voltage generator. The voltage levels on the two polarity comparator inputs, POL0 and POL1, are compared with the reference voltage V_{ref} . If $POL0 < V_{ref}$ or $POL1 > V_{ref}$, POL0 and POL1 (Status register, bit 7 and 6) are set respectively and reset if $POL0 > V_{ref}$ and $POL1 < V_{ref}$. Every time the POL0 status bit changes from logic 1 to logic 0, a POL0 interrupt is generated. Every time the POL1 status bit changes from logic 0 to logic 1, a POL1 interrupt is generated.

The period time of a POL1-POL0-POL1 sequence is available in the Ringer period register. It is preset to 255 on power-on and updated every time a POL1 interrupt is generated. The sequence is:

1. Power-on: Ringer period register = 255
2. First POL1 interrupt: Ringer period register = 255
3. First POL1 interrupt after a POL0 interrupt: Ringer period register = new time
4. First POL1 interrupt after more than $\frac{255}{2048}$ s: Ringer period register = 255.

The period is given in multiples of $\frac{1}{2048}$ s. The maximum value is 255.

The POL1-POL0-POL1 sequence is recognized when one or more POL1 interrupts are generated followed by one or more POL0 interrupts, followed by a POL1 interrupt. The 32.768 kHz clock is needed for the generation of a polarity interrupt.

7.5 Low battery detection

The low battery voltage detection input (pin LOWBAT) is connected to the positive input of a comparator. The negative input is connected to the internal reference voltage. If the voltage on the LOWBAT input pin is less than the reference voltage V_{ref} , the LOW-BAT Indication (Status register, bit 5) is set. If the LOWBAT input rises above V_{ref} again, the LOW-BAT Indication is cleared.

The 32.768 kHz clock signal must be available. The LOW-BAT Indication bit does not generate interrupts, thus the bit should be polled.

7.6 Level detect

When the input signal level on the FSK or the CAS input (the one that is selected) is below a threshold of typically -40 dBm, the Low Level Status bit will be set (Interrupt register, bit 4). The level detector can be used to observe a carrier loss during FSK transmission and to detect the 'Idle State Tone Alert Signal' for British Telecom. The signal power on the input can be monitored by polling the register bit since it will not generate an interrupt. Signal power is measured in a frequency band corresponding to the selected operation mode, FSK (1000 to 2200 Hz) or CAS (2000 to 2800 Hz).

The Low Level Status bit will be updated every 8 ms. When FSK and CAS are both disabled the signal level on the FSK input is measured. The 32.768 kHz clock signal must be available.

7.7 Time base

The 32.768 kHz oscillator is used to generate either a 1 second or a 1 minute interrupt signal. If the TB on/off bit is set (Mode register 2, bit 6) every second or minute an interrupt is generated and MIN Interrupt and/or SEC Interrupt bits (Interrupt register, bit 7 and 6) are set. After reading the Interrupt register the interrupt is cleared.

The SEC/MIN (Mode register 2, bit 5) selects whether every second (SEC/MIN is set) or every minute (SEC/MIN is cleared) an interrupt is generated. All possible selections are shown in Table 3. Resetting bit TB on/off in Mode register 2 (bit 6) will only disable time base interrupts, and the 32.768 kHz oscillator will continue to run.

7.8 Interrupt

The interrupt request output (IRQ) is active HIGH by default. The polarity of the IRQ output can be made active LOW by the INT Polarity HIGH/LOW bit (Mode register 1, bit 3). The IRQ pin is in 3-state when not active, so an external pull-up or pull-down resistor is required. The interrupt cause is indicated by the flags in the Interrupt register. Interrupt flags are set by hardware but must be reset by software. All flags of the Interrupt register are reset when the register is read via I²C-bus interface.

The IRQ pin is deactivated at the positive edge of SCL which reads the first data bit of the Interrupt register. The IRQ pin will stay inactive for one SCL cycle. IRQ can handle a next interrupt after the next positive edge of SCL.

Table 3: Selection of interrupt modes

Mode register 2 (CIDMD2)		Interrupt register (CIDINT)		Interrupt
TB on/off (CIDMD2.6)	SEC/MIN (CIDMD2.5)	MIN Interrupt (CIDINT.7)	SEC Interrupt (CIDINT.6)	
0	X ^[1]	0	0	no time base interrupt (time base is reset)
1	0	1	0	every minute an interrupt is generated; no second interrupt
1	1	1	1	every second an interrupt is generated; every minute an interrupt is generated

[1] X = don't care.

7.9 The internal Power-on reset (POR)

The device contains an on-chip Power-on reset circuitry which activates a reset as long as V_{DD} is below a predefined level $V_{POR(H)}$. If V_{DD} exceeds $V_{POR(H)}$, the 3.58 MHz oscillator will start. The PCD3316 is initialized and the internal registers are set to the default value (see [Section 7.13](#)). It takes a maximum of 100 cycles of the 3.58 MHz clock to initialize all internal functions. The POR circuitry also ensures, that the chip will be switched off as soon as a falling V_{DD} reaches a predefined level ($V_{POR(L)}$).

7.10 3.58 MHz oscillator circuitry

The 3.58 MHz oscillator is needed for the FSK receiver and the CAS detection. This on-chip Amplitude Controlled Oscillator (ACO) circuitry is a single-stage inverting amplifier biased by an internal feedback resistor R_{fb} . The oscillator circuit is shown in [Figure 5](#). When using a quartz resonator to drive the oscillator, normally no external components are needed.

When using ceramic resonators to drive the oscillator, in some cases external components are needed; refer to the ceramic resonator product specifications. Two different configurations are shown in [Figure 6a](#) and [Figure 6b](#).

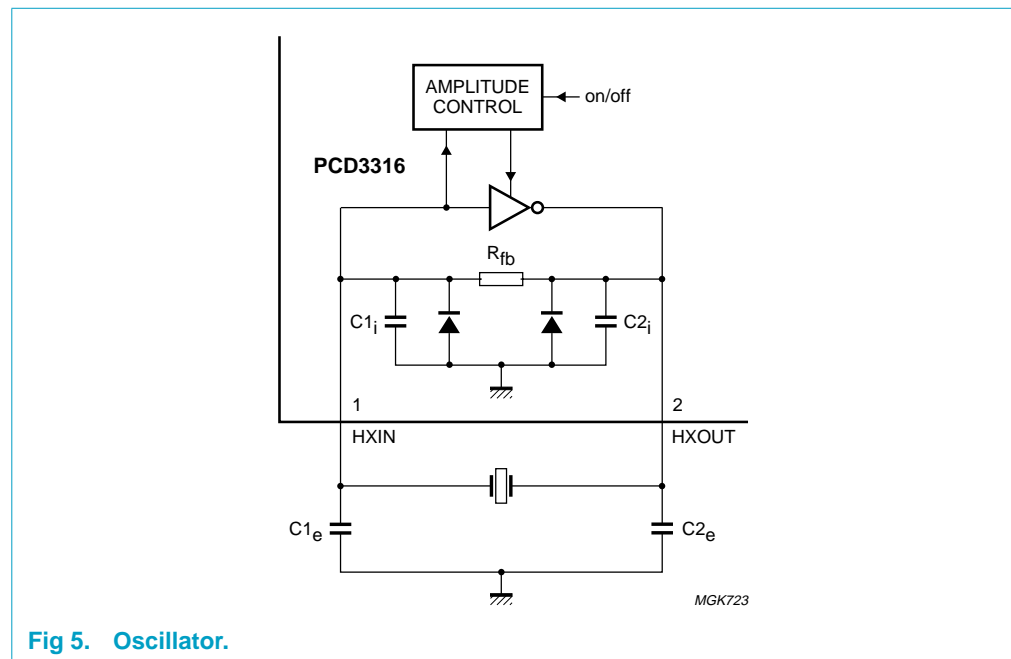

Fig 5. Oscillator.

To drive the device with an external clock source, apply the external clock signal to HXIN, and leave HXOUT to float, as shown in [Figure 6c](#). If the amplitude of the input signal is less than V_{DD} to DGND or a sine wave is applied, capacitive decoupling is needed as shown in [Figure 6d](#).

In the Power-down mode (Mode register 2, bit 7 = 0), the oscillator is stopped and HXIN and HXOUT are internally pulled LOW. The current of the whole oscillator is switched off.

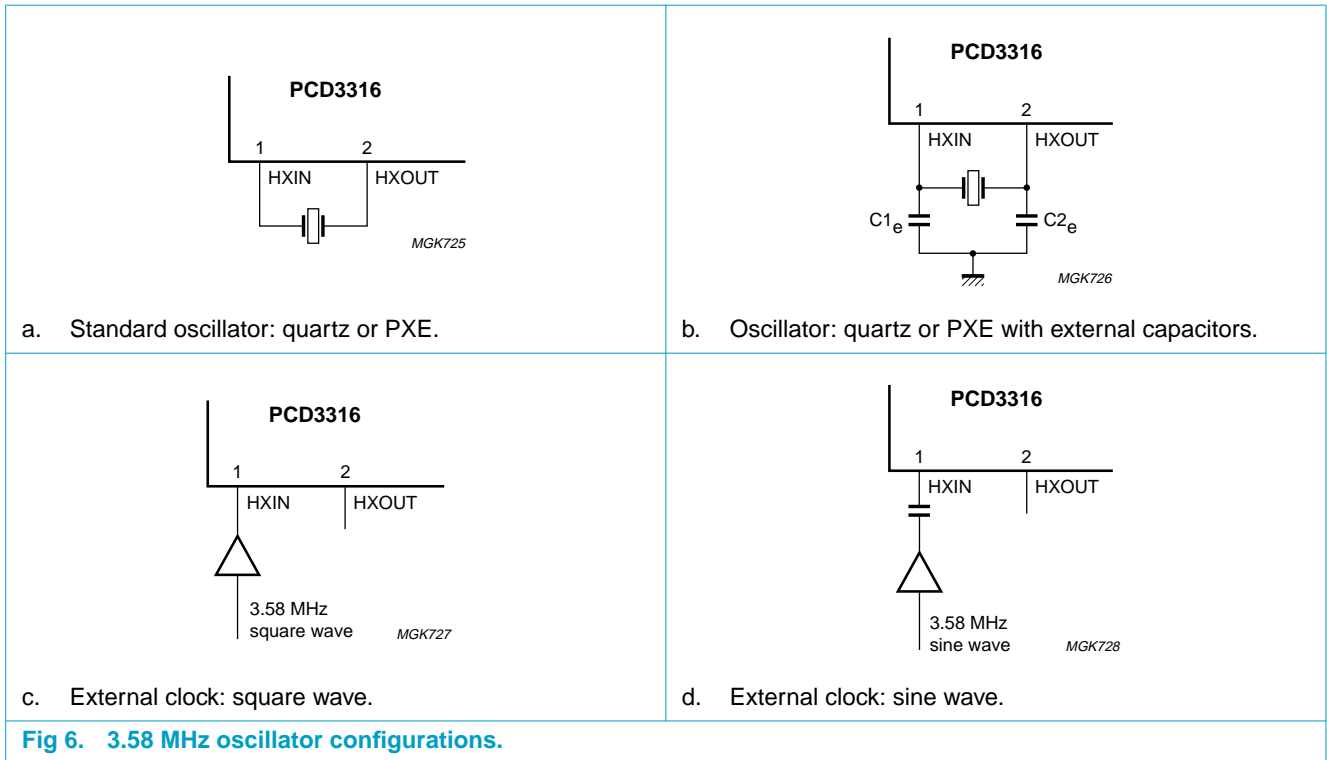

Fig 6. 3.58 MHz oscillator configurations.

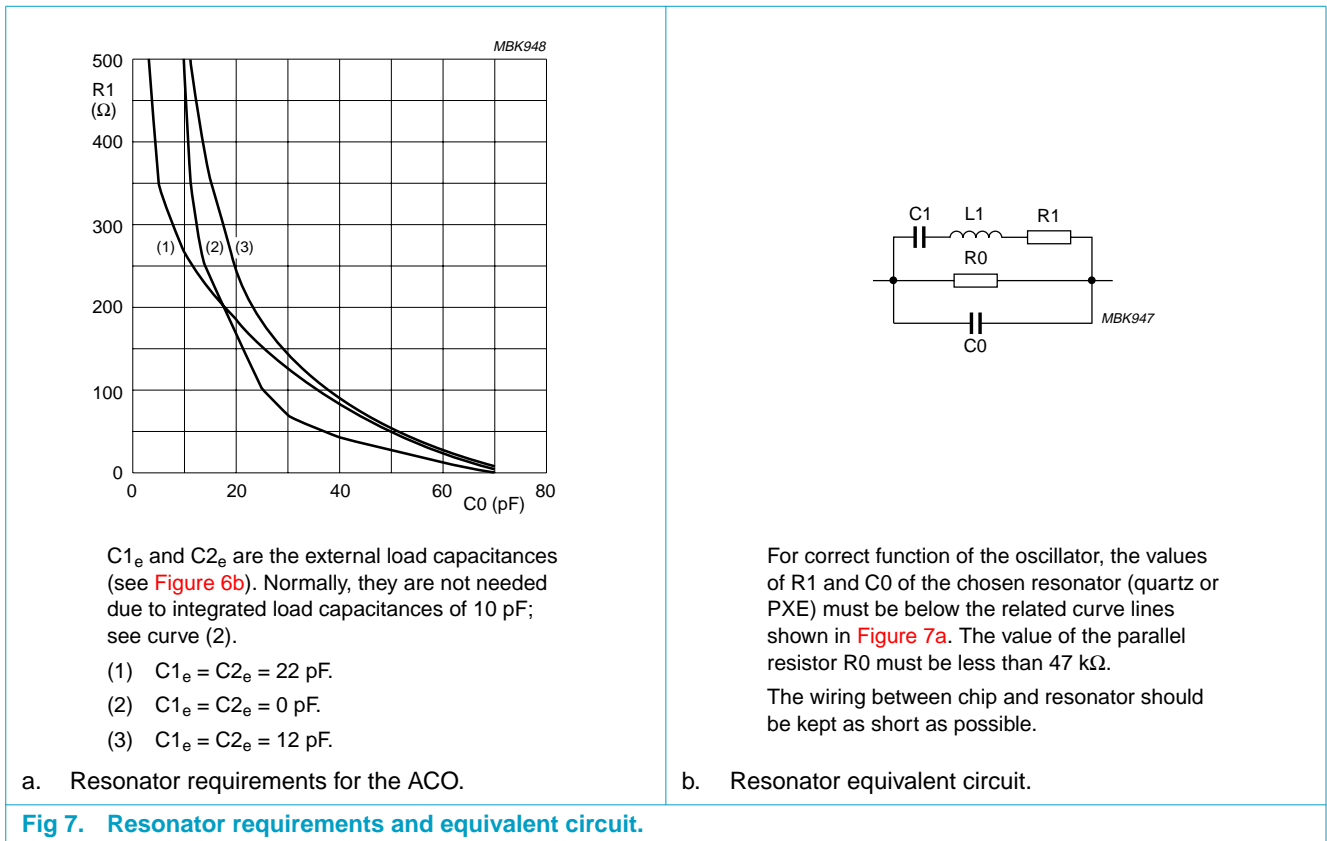

Fig 7. Resonator requirements and equivalent circuit.

7.11 32 kHz oscillator

The 32.768 kHz oscillator is enabled permanently and is used to generate either a 1 second or 1 minute interrupt. The 32.768 kHz clock is also used for the 'Ring or polarity change detector', the 'Low battery detection' and the 'Level detect' function.

An external 32.768 kHz signal may be applied to pin LXIN while leaving pin LXOUT not connected.

The 32 kHz oscillator requires an external 32.768 kHz quartz crystal and an external feedback resistor (4.7 M Ω) between the LXIN and LXOUT pins (see [Figure 8](#)).

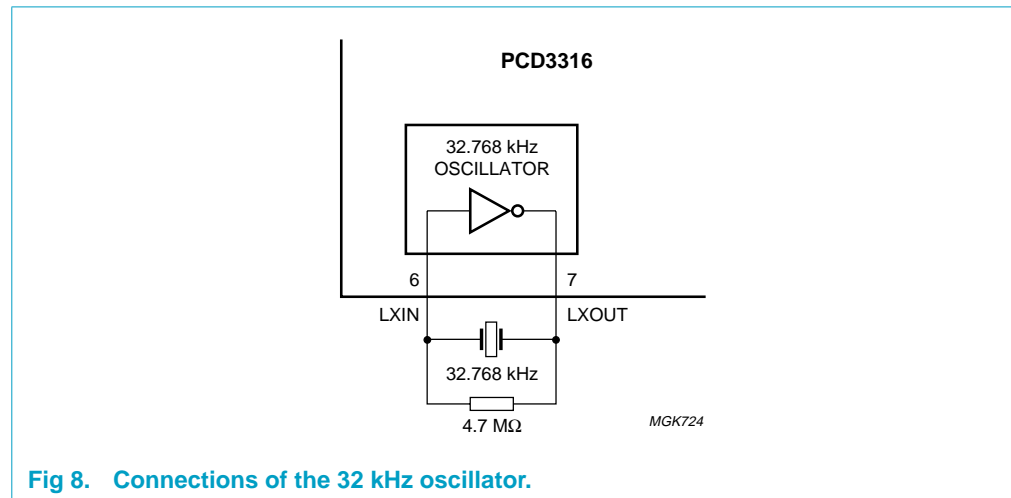

Fig 8. Connections of the 32 kHz oscillator.

7.12 Serial interface

The serial interface of the PCD3316 is the I²C-bus. A detailed description of the I²C-bus specification, including applications, is given in the brochure: *The I²C-bus and how to use it*, order no. 9398 393 40011 or *I²C Peripherals Data Handbook IC12*.

7.12.1 Characteristics of the I²C-bus

For the I²C-bus configuration see [Figure 9](#). A device generating a message is a 'transmitter', a device receiving a message is the 'receiver'. The device that controls the message is the 'master' and the devices which are controlled by the master are called the 'slaves'. The PCD3316 operates in the slave transmitter/receiver mode only.

The I²C-bus is for bidirectional, two-line communication between different ICs or modules. The two lines are a serial data line (SDA) and a serial clock line (SCL). Both lines must be connected to a positive supply via a pull-up resistor. Data transfer may be initiated only when the bus is not busy.

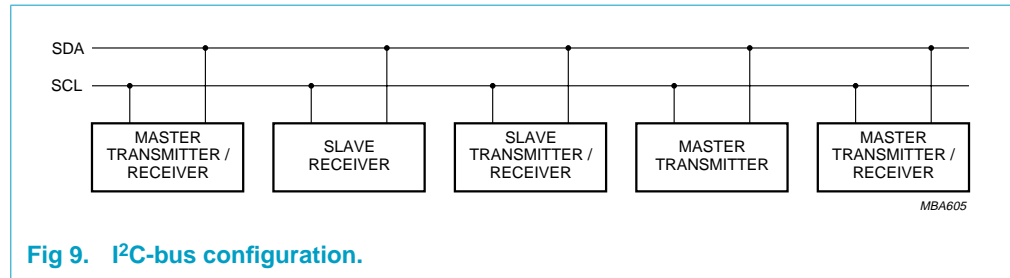

Fig 9. I²C-bus configuration.

7.12.2 START and STOP conditions

Both data and clock lines remain HIGH when the bus is not busy. A HIGH-to-LOW transition of the data line, while the clock is HIGH is defined as the START condition (S). A LOW-to-HIGH transition of the data line while the clock is HIGH is defined as a STOP condition (P); see Figure 10.

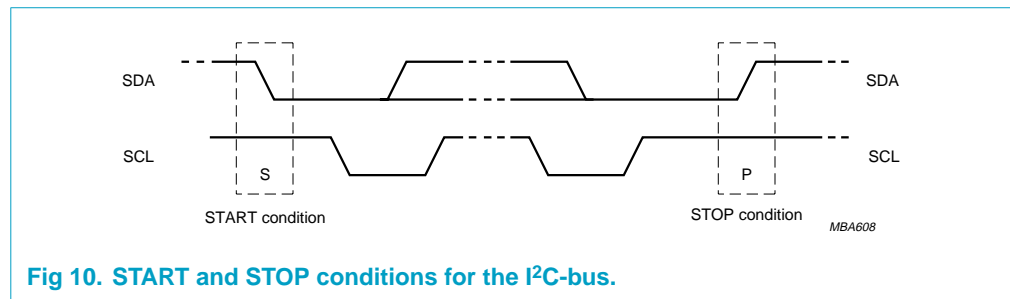

Fig 10. START and STOP conditions for the I²C-bus.

7.12.3 Bit transfer

One data bit is transferred during each clock pulse. The data on the SDA line must remain stable during the HIGH period of the clock pulse as changes in the data line at this time will be interpreted as a control signal; see Figure 11.

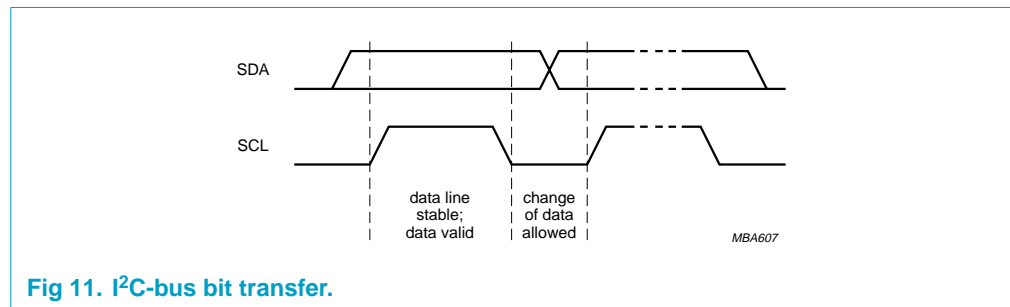

Fig 11. I²C-bus bit transfer.

7.12.4 Acknowledge

The number of data bytes transferred between the START and the STOP conditions from the transmitter to the receiver is unlimited. Each byte of eight bits is followed by an acknowledge bit. The acknowledge bit is a HIGH level signal put on the bus by the transmitter during which time the master generates an extra acknowledge-related clock pulse.

A slave receiver which is addressed must generate an acknowledge after the reception of each byte. Also a master receiver must generate an acknowledge after the reception of each byte that has been clocked out of the slave transmitter.

The device that acknowledges must pull down the SDA line during the acknowledge clock period immediately after the 8th SCL pulse, so that the SDA line is stable LOW during the HIGH period of the acknowledge related clock pulse (set-up and hold times must be taken into consideration).

A master receiver must signal an end of data to the transmitter by not generating an acknowledge on the last byte that has been clocked out of the slave. In this event the transmitter must leave the data line HIGH to enable the master to generate a STOP condition.

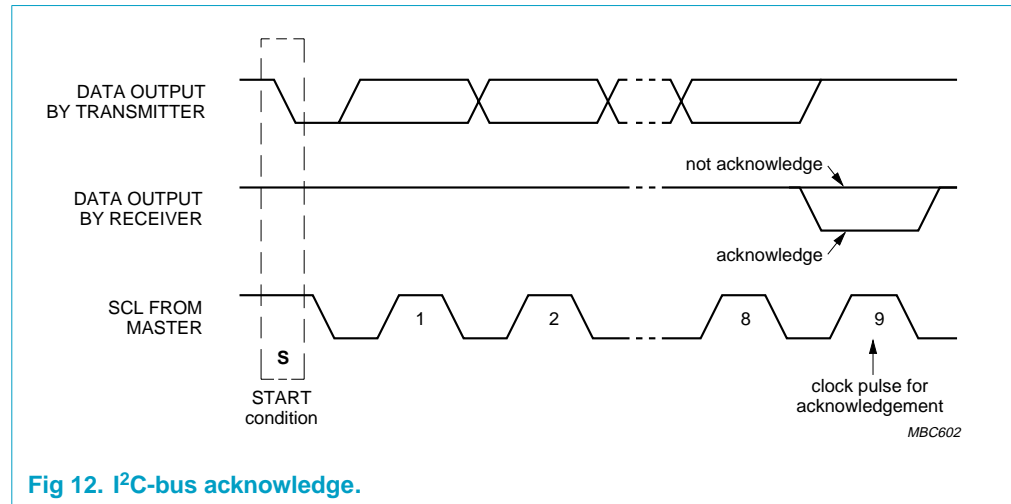

Fig 12. I²C-bus acknowledge.

7.12.5 I²C-bus protocol

Before any data is transmitted on the I²C-bus, the device which should respond is addressed first. The addressing is always carried out with first byte transmitted after the START procedure. One I²C-bus slave address is reserved for the PCD3316, E0H (1110 0000 for write and 1110 0001 for read).

The I²C-bus protocol is shown in Figure 13. Two different sequences are considered, the write sequence and the read sequence. Both sequences are initiated with a START condition (S) from the I²C-bus master which is followed by the PCD3316 slave address with the read bit cleared. The first byte after the I²C-bus address is interpreted as the address of a PCD3316 register. During the write sequence the register address of the PCD3316 is auto-incremented on each acknowledge. The write sequence is ended with a STOP condition from the master. If the addressed register is read-only or non-existent, nothing will be changed.

For the read sequence the bus master issues a repeated START condition followed by the PCD3316 slave address with the read bit set. Then data is read from previously set address and sent out. When the master responds with an acknowledge the address of the register is auto incremented and the slave will put the data from the next register on the bus. The read sequence is stopped when the master stops giving an acknowledge and generates a STOP condition.

When a non-existing register is addressed the PCD3316 will return FFH. Existing register addresses are shown in Section 7.13. An additional register address (73H) is reserved for test purposes. This address cannot be reached with the auto-increment function of the I²C-bus interface.

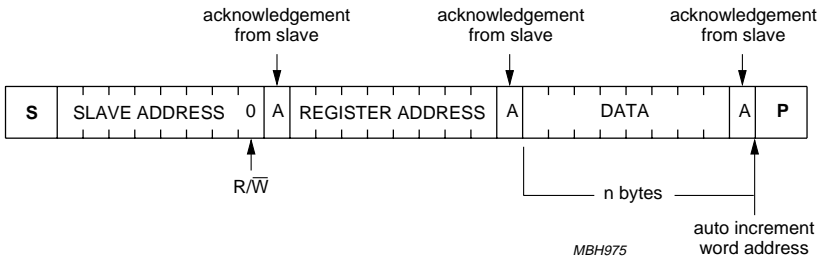

a. I²C-bus write sequence.

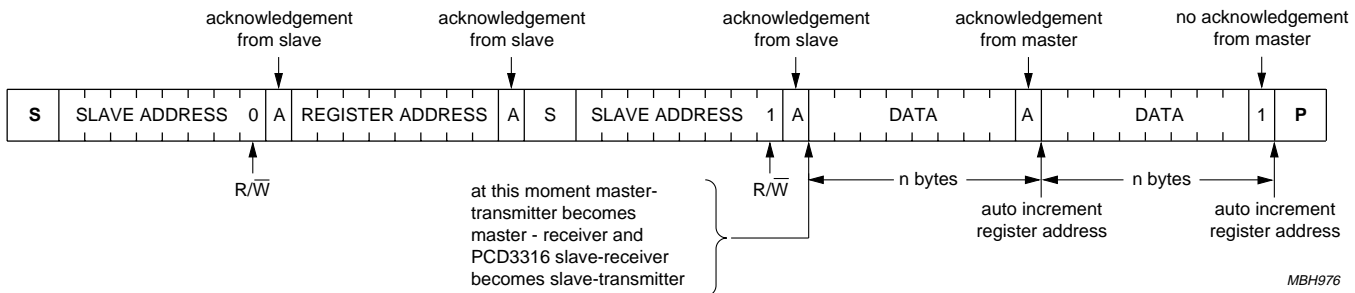

b. I²C-bus read sequence.

Fig 13. I²C-bus write and read sequence.

7.12.6 I²C-bus bit rate

When a microcontroller is used that implements an I²C-bus in software, the bit rate of the I²C-bus can be critical during reception of FSK. The collection of the interrupt data and FSK-data from the PCD3316 takes 48 bits on the I²C-bus. With an FSK baud rate of 1200 (corresponds to 1200 bits per second) the minimal speed of the I²C-bus should be 5.76 kbits/s. Additional interrupts generated by the time base of the PCD3316 will cause the processor to collect extra information from the PCD3316.

As a consequence, the FSK-data can be overrun in the PCD3316 and one data byte will be lost. In this case, the time base interrupt should be suppressed while FSK is active. This can be done by setting the 'INT-SUP on/off' bit (bit 4 in Mode register 2). The 'TB on/off' bit (bit 6 in Mode register 2) will still be set but the IRQ output will not be activated by the time base interrupt. Any time base interrupt can be detected by the microcontroller when an FSK interrupt is processed by reading the Interrupt register.

7.13 Registers

Table 4: Register overview

Address	Name	Function	Read/Write	Default value
00H	CIDINT	Interrupt register	read only	0000 0000
01H	CIDFSK	FSK data register	read only	–
02H	CIDSTA	Status register	read only	–
03H	CIDRNG	Ringer period register	read only	–
04H	CIDMD1	Mode register 1	read/write	0101 1000
05H	CIDMD2	Mode register 2	read/write	1101 0000

7.13.1 Interrupt register (CIDINT)

Table 5: Interrupt register

Address: 00H; read only.

7	6	5	4	3	2	1	0
MIN Interrupt	SEC Interrupt	FSK Interrupt	Low Level Status	POL1 Interrupt	POL0 Interrupt	CAS Interrupt	–

Table 6: Description of CIDINT bits

Bit	Symbol	Description
CIDINT.7	MIN Interrupt	MIN Interrupt = 0: no interrupt request; MIN Interrupt = 1: one minute interrupt request
CIDINT.6	SEC Interrupt	SEC Interrupt = 0: no interrupt request; SEC Interrupt = 1: one second interrupt request
CIDINT.5	FSK Interrupt	FSK Interrupt = 0: no FSK interrupt or FSK disabled; FSK Interrupt = 1: FSK interrupt, one byte received
CIDINT.4	Low Level Status	Low Level Status = 0: signal level on selected input above power reference (no interrupt); Low Level Status = 1: signal level on selected input below power reference (no interrupt)
CIDINT.3	POL1 Interrupt	POL1 Interrupt = 0: no zero to one changes on POL1 input or polarity interrupt disabled; POL1 Interrupt = 1: a one to zero input change on the POL1 input is detected
CIDINT.2	POL0 Interrupt	POL0 Interrupt = 0: no one to zero changes on POL0 input or polarity interrupt disabled; POL0 Interrupt = 1: a zero to one input change on the POL0 input is detected
CIDINT.1	CAS Interrupt	CAS Interrupt = 0: no CAS signal detected or CAS disabled; CAS Interrupt = 1: CAS signal detected
CIDINT.0	–	reserved bit

7.13.2 FSK data register (CDFS)K

Table 7: Interrupt register

Address: 01H; read only.

7	6	5	4	3	2	1	0
D7	D6	D5	D4	D3	D2	D1	D0

Table 8: Description of CDFS)K bits

Bit	Symbol	Description
CDFS)K.7 to CDFS)K.0	D7 to D0	If an FSK interrupt has occurred and no FSK error is detected, the FSK data register contains valid data.

7.13.3 Status register (CIDSTA)

Table 9: Status register

Address: 02H; read only.

7	6	5	4	3	2	1	0
POL1	POL0	LOW-BAT Indication	FSK-BOM Indication	FSK-OVR Error	FSK-FRM Error	–	–

Table 10: Description of CIDSTA bits

Bit	Symbol	Description
CIDSTA.7	POL1	POL1 = 0: voltage on input POL1 < V _{ref} ; POL1 = 1: voltage on input POL1 > V _{ref}
CIDSTA.6	POL0	POL0 = 0: voltage on input POL0 > V _{ref} ; POL0 = 1: voltage on input POL0 < V _{ref}
CIDSTA.5	LOW-BAT Indication	LOW-BAT Indication = 0: voltage on input LOWBAT > V _{ref} ; LOW-BAT Indication = 1: voltage on input LOWBAT < V _{ref}
CIDSTA.4	FSK-BOM Indication	FSK-BOM Indication = 0: begin of mark period not yet detected; FSK-BOM Indication = 1: begin of mark period detected
CIDSTA.3	FSK-OVR Error	FSK-OVR Error = 0: no FSK overrun error; FSK-OVR Error = 1: FSK overrun error, data byte(s) lost
CIDSTA.2	FSK-FRM Error	FSK-FRM Error = 0: no FSK frame error; FSK-FRM Error = 1: FSK frame error, stop bit was wrong
CIDSTA.1 and CIDSTA.0	–	reserved bits

7.13.4 Ringer period register (CIDRNG)

Table 11: Register format

Address: 03H; read only.

7	6	5	4	3	2	1	0
D7	D6	D5	D4	D3	D2	D1	D0

Table 12: Description of CIDRNG bits

Bit	Symbol	Description
CIDRNG.7 to CIDRNG.0	D7 to D0	The value held in this byte denotes the time between two positive edges of the POL1 comparator output (between two positive edges of POL1 one positive edge of POL0 must have been detected).

7.13.5 Mode register 1 (CIDMD1)

Table 13: Mode register 1

Address: 04H; read/write.

7	6	5	4	3	2	1	0
FSK on/off	FSK-BOM-mask on/off	CAS on/off	POL on/off	INT polarity HIGH/LOW	–	–	–

Table 14: Description of CIDMD1 bits

Bit	Symbol	Description
CIDMD1.7	FSK on/off	FSK on/off = 0: FSK receiver disabled; FSK on/off = 1: FSK receiver enabled
CIDMD1.6	FSK-BOM-mask on/off	FSK-BOM-mask on/off = 0: FSK interrupts will be generated when a data word was received even before mark period (data from channel seizure); FSK-BOM-mask on/off = 1: FSK interrupts will only be generated after the mark period was detected (no interrupts from channel seizure)
CIDMD1.5	CAS on/off	CAS on/off = 0: CAS detector disabled; CAS on/off = 1: CAS detector enabled
CIDMD1.4	POL on/off	POL on/off = 0: disable interrupts due to polarity change; POL on/off = 1: enable interrupts due to polarity change
CIDMD1.3	INT polarity HIGH/LOW	INT polarity HIGH/LOW = 0: interrupt pin active LOW; INT polarity HIGH/LOW = 1: interrupt pin active HIGH
CIDMD1.2 to CIDMD1.0	–	reserved bits

7.13.6 Mode register 2 (CIDMD2)

Table 15: Mode register 2

Address: 05H; read/write.

7	6	5	4	3	2	1	0
XTAL on/off	TB on/off	SEC/MIN	INT-SUP on/off	–	–	–	–

Table 16: Description of CIDMD2 bits

Bit	Symbol	Description
CIDMD2.7	XTAL on/off	XTAL on/off = 0: disable 3.58 MHz oscillator; XTAL on/off = 1: enable 3.58 MHz oscillator
CIDMD2.6	TB on/off	TB on/off = 0: disable 32.768 kHz timebase; TB on/off = 1: enable 32.768 kHz timebase
CIDMD2.5	SEC/MIN	SEC/MIN = 0: every minute a timebase interrupt; SEC/MIN = 1: every second a timebase interrupt
CIDMD2.4	INT-SUP on/off	INT-SUP on/off = 0: enable SEC/MIN interrupts during FSK reception; INT-SUP on/off = 1: disable SEC/MIN interrupts during FSK reception
CIDMD2.3 to CIDMD2.0	–	reserved bits

8. Limiting values

Table 17: Limiting values

In accordance with the Absolute Maximum Rating System (IEC 60134).

Symbol	Parameter	Conditions	Min	Max	Unit
V _{DD}	supply voltage		-0.5	+5.0	V
I _{DD}	supply current		-	50	mA
I _I	DC input current at any input		-10	+10	mA
I _O	DC output current at any output		-10	+10	mA
V _I	input voltage on all inputs		-0.5	V _{DD} + 0.5 [1]	V
P _{tot}	total power dissipation		-	300	mW
P _O	power dissipation per output		-	10	mW
T _{amb}	operating ambient temperature		-25	+70	°C
T _{stg}	storage temperature		-65	+150	°C

[1] V_{I(max)} = 5.0 V.

9. Characteristics

Table 18: Characteristics

V_{DD} = 2.5 to 3.6 V; T_{amb} = -25 to +70 °C; HXIN = 3.579545 MHz ±0.05%; LXIN = 32.768 kHz ±0.1%; unless otherwise specified.

Symbol	Parameter	Conditions	Min	Typ	Max	Unit
V _{DD}	supply voltage		[1] 2.5	3.3	3.6	V
V _{POR(H)}	power-on reset HIGH voltage		1.85	2.05	2.25	V
V _{hys(POR)}	power-on reset hysteresis voltage		[2] 50	100	150	mV
I _{DD}	supply currents	V _{DD} = 2.5 V				
	Power-down mode		[3] -	30	70	µA
	operating		[3][4] -	2.0	2.3	mA

Low voltage and polarity comparators (pins LOWBAT, POL0 and POL1)

V _{hys}	hysteresis voltage		-	20	-	mV
I _{LI}	input leakage current		[5] -	-	1	µA

Internal reference

V _{ref}	reference voltage level		1.125	1.25	1.375	V
P _{i(ref)}	input signal reference power for Low Level Status bit	in 600 Ω load	[6] -43.8	-	-37.8	dBm
t _{r(level)}	input signal to Low Level Status bit rise time	input signal power < P _{i(ref)}	-	-	8	ms
t _{f(level)}	input signal to Low Level Status bit fall time	input signal power > P _{i(ref)}	-	-	8	ms

Logical output (pin IRQ) [7]

I _{OL}	LOW-level output current	V _{IRQ} = 0.4 V	2	-	-	mA
I _{OH}	HIGH-level output current	V _{IRQ} = V _{DD} - 0.4 V	2	-	-	mA

Table 18: Characteristics...continued

$V_{DD} = 2.5$ to 3.6 V; $T_{amb} = -25$ to $+70$ °C; $HXIN = 3.579545$ MHz $\pm 0.05\%$; $LXIN = 32.768$ kHz $\pm 0.1\%$; unless otherwise specified.

Symbol	Parameter	Conditions	Min	Typ	Max	Unit
FSK receiver (pins FSKIN+ and FSKIN-)						
Z_i	input impedance FSKIN+ to FSKIN-		–	1.4	–	M Ω
$Z_{source(max)}$	maximum source impedance		–	–	200	k Ω
$P_{i(FSKIN)}$	input signal power	in 600 Ω load	[8] –50	–	0	dBm
S/N_{FSK}	signal-to-noise ratio	200 to 3400 Hz	20	–	–	dB
$ V_{dif} $	differential voltage between mark and space (twist)		–	–	10	dB
$f_{(D)}$	data transmission rate frequency		1 180	1 200	1 212	bits/s
f_s	space frequency		2 068	–	2 222	Hz
f_m	mark frequency		1 188	–	1 320	Hz
CAS detector (pin CASIN)						
Z_i	input impedance CASIN to V_{ref}		–	1.4	–	M Ω
$Z_{source(max)}$	maximum source impedance		–	–	200	k Ω
P_i	input signal power	in 600 Ω load	[8] –37.8	–	0	dBm
$TH_{ns(CAS)}$	no signal threshold (CAS)	in 600 Ω load	–43.8	–	–37.8	dBm
f_l	low tone frequency		–	2 130	–	Hz
f_h	high tone frequency		–	2 750	–	Hz
Δf_{max}	maximum frequency deviation		[9] –0.5	–	+0.5	%
V_{dif}	differential voltage level (twist)		[9] –	–	6	dB
t_{dt}	dual tone detection time		60	–	–	ms
I²C-bus interface (pins SCL and SDA) [10]; see Figure 14						
V_{IL}	LOW-level input voltage		[11] 0	–	$0.3V_{DD}$	V
V_{IH}	HIGH-level input voltage		[11] $0.7V_{DD}$	–	V_{DD}	V
I_{OL1}	LOW-level output current for pin SDA	$V_{O(SDA)} = 0.4$ V	2	–	–	mA
C_i	input capacitance for each I/O pin		–	–	10	pF
f_{SCL}	SCL clock frequency		–	–	100	kHz
t_{BUF}	bus free time		4.7	–	–	μ s
$t_{SU:STA}$	START condition set-up time		4.7	–	–	μ s
$t_{HD:STA}$	START condition hold time		4.0	–	–	μ s
t_{LOW}	SCL LOW time		4.7	–	–	μ s
t_{HIGH}	SCL HIGH time		4.0	–	–	μ s
t_r	maximum SCL and SDA rise time		[12] –	–	1 000	ns
t_f	maximum SCL and SDA fall time		[12] –	–	300	ns
$t_{SU:DAT}$	data set-up time		250	–	–	ns
$t_{HD:DAT}$	data hold time		0	–	–	ns
$t_{VD:DAT}$	SCL LOW to data out valid time		–	–	3.4	μ s
$t_{SU:STO}$	STOP condition set-up time		4.0	–	–	μ s

Table 18: Characteristics...continued

$V_{DD} = 2.5$ to 3.6 V; $T_{amb} = -25$ to $+70$ °C; $HXIN = 3.579545$ MHz $\pm 0.05\%$; $LXIN = 32.768$ kHz $\pm 0.1\%$; unless otherwise specified.

Symbol	Parameter	Conditions	Min	Typ	Max	Unit
3.58 MHz oscillator (pins HXIN and HXOUT)						
$V_{HXIN(p-p)}$	external clock signal amplitude (peak-to-peak value) on pin HXIN		0.5	–	V_{DD}	V
$Z_{i(HXIN)}$	input impedance on pin HXIN		300	1000	–	k Ω
C_{1i} ; C_{2i}	input capacitance on pins HXIN and HXOUT [13]		–	10	–	pF
32 kHz oscillator (pins LXIN and LXOUT)						
g_m	transconductance	$V_{i(p-p)} < 50$ mV	2	4	10	μ S
$C_{i(LXIN)}$	LXIN input capacitance		–	13	–	pF
$C_{o(LXOUT)}$	LXOUT output capacitance		–	10	–	pF

- [1] Except for FSK and CAS detection, all circuitry works already when $V_{DD} > V_{POR(H)}$. Since the I²C-bus interface will work (starts to acknowledge), the application can start reading the LOW-BAT Indication bit (Status register, bit 5) to check whether the supply voltage has reached the operating voltage level. A voltage divider network can be connected to pins V_{DD} , LOWBAT and AGND/DGND such that $V_{LOWBAT} = V_{ref}$ if $V_{DD} = V_{DD(min)}$.
- [2] The power-on reset LOW level is defined as $V_{POR(L)} = V_{POR(H)} - V_{hys(POR)}$. By design $V_{POR(L)}$ is always lower than $V_{POR(H)}$.
- [3] 32 kHz oscillator on (MIN Interrupt, SEC Interrupt, Polarity change, Low battery and Level detect available).
- [4] 3.58 MHz oscillator on (device fully operational).
- [5] $GND < V_i < V_{DD}$. The leakage currents are generally very small, < 1 nA. The value given here, 1 μ A, is a maximum that can occur after an Electrostatic Stress on the pin.
- [6] When FSK is selected the signal power is measured between 1000 and 2200 Hz. When CAS is selected signal levels are measured between 2000 and 2800 Hz.
- [7] The IRQ pin is implemented as a 3-state pin which is only active (either HIGH or LOW) when an interrupt occurs. A pull-up or pull-down has to be connected to define the line when no interrupt is generated.
- [8] Verified on sampling basis.
- [9] According to Bellcore specification: near end speech level ≤ -7 dBm ASL (ASL = Active Speech Level), referenced to 600 Ω , according to method B of recommendation P.56.
- [10] Pins SCL and SDA are equipped with an open-drain output buffer. The pins have no clamp diode to V_{DD} .
- [11] The input threshold voltage of SCL and SDA meet the I²C-bus specification. Therefore, an input voltage below $0.3V_{DD}$ will be recognized as a logic 0 and an input voltage above $0.7V_{DD}$ will be recognized as a logic 1
- [12] Maximum capacitive load for each bus line is 400 pF.
- [13] C_{1i} and C_{2i} are the total internal capacitances (including gate capacitance and leadframe capacitance).

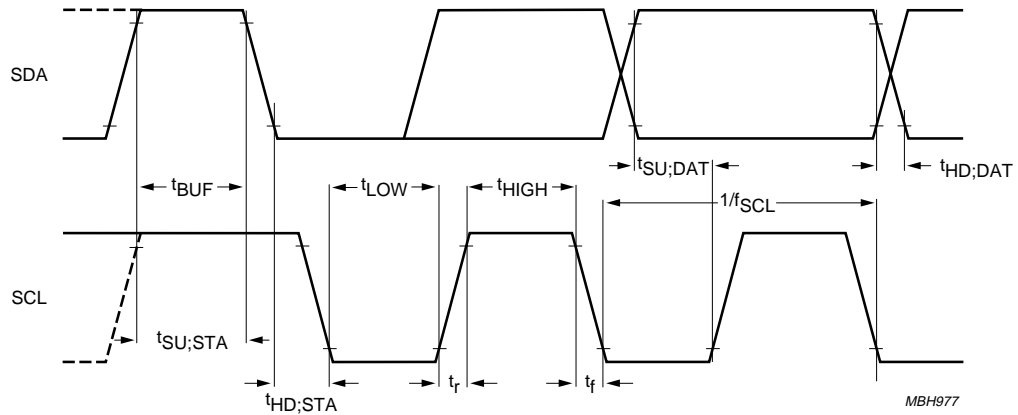

a. Timing diagram 1.

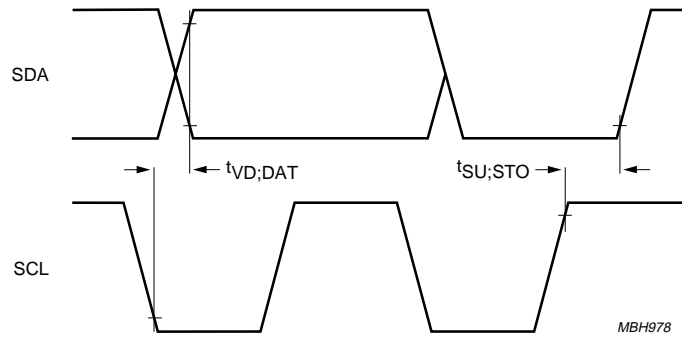

b. Timing diagram 2.

Fig 14. I²C-bus timing.

10. Application information

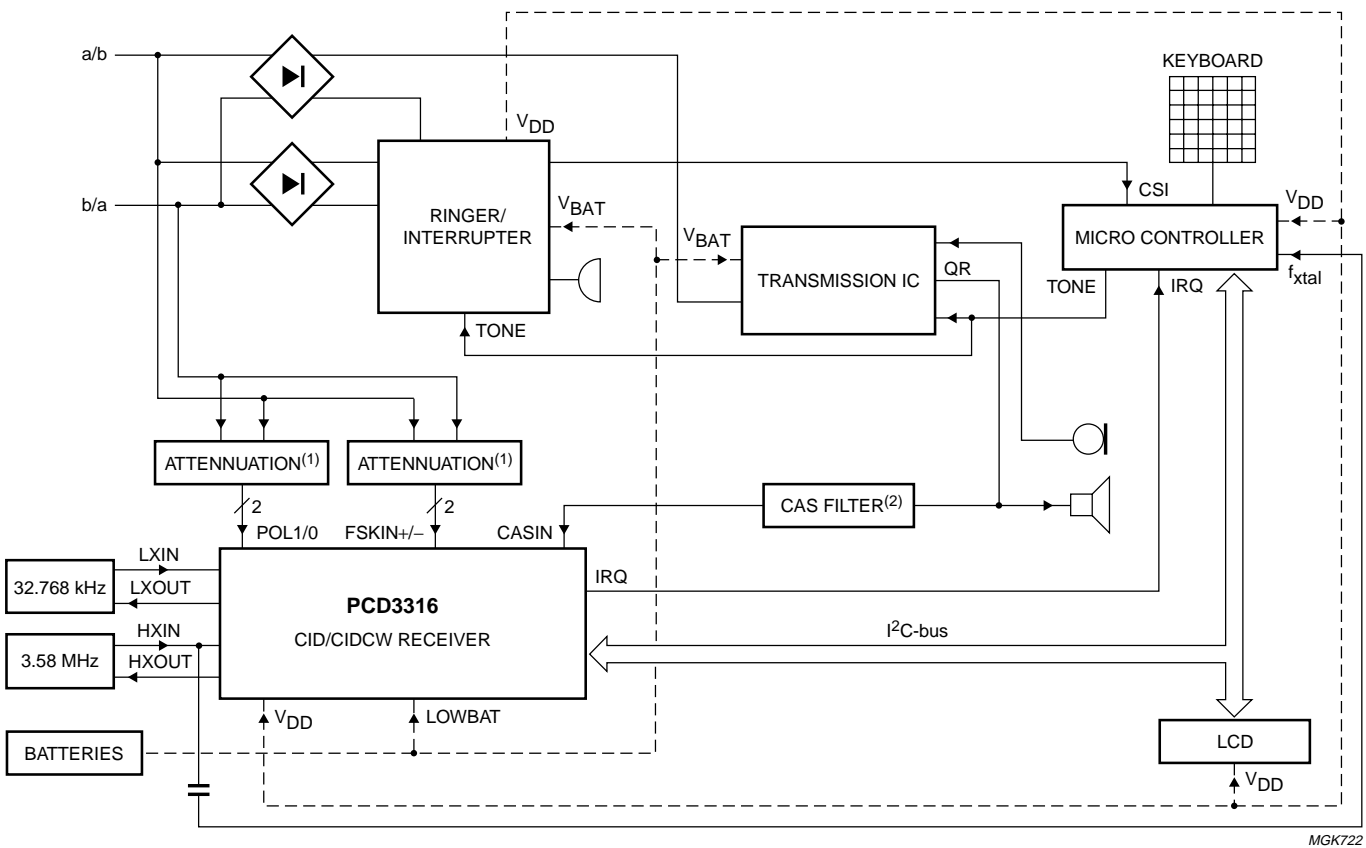

A demo-board (OM5843) of this configuration is available. Please contact your Philips sales office.

- (1) See [Figure 16a](#).
- (2) See [Figure 16b](#).

Fig 15. Application diagram for a telephone with CID/CIDCW functionality.

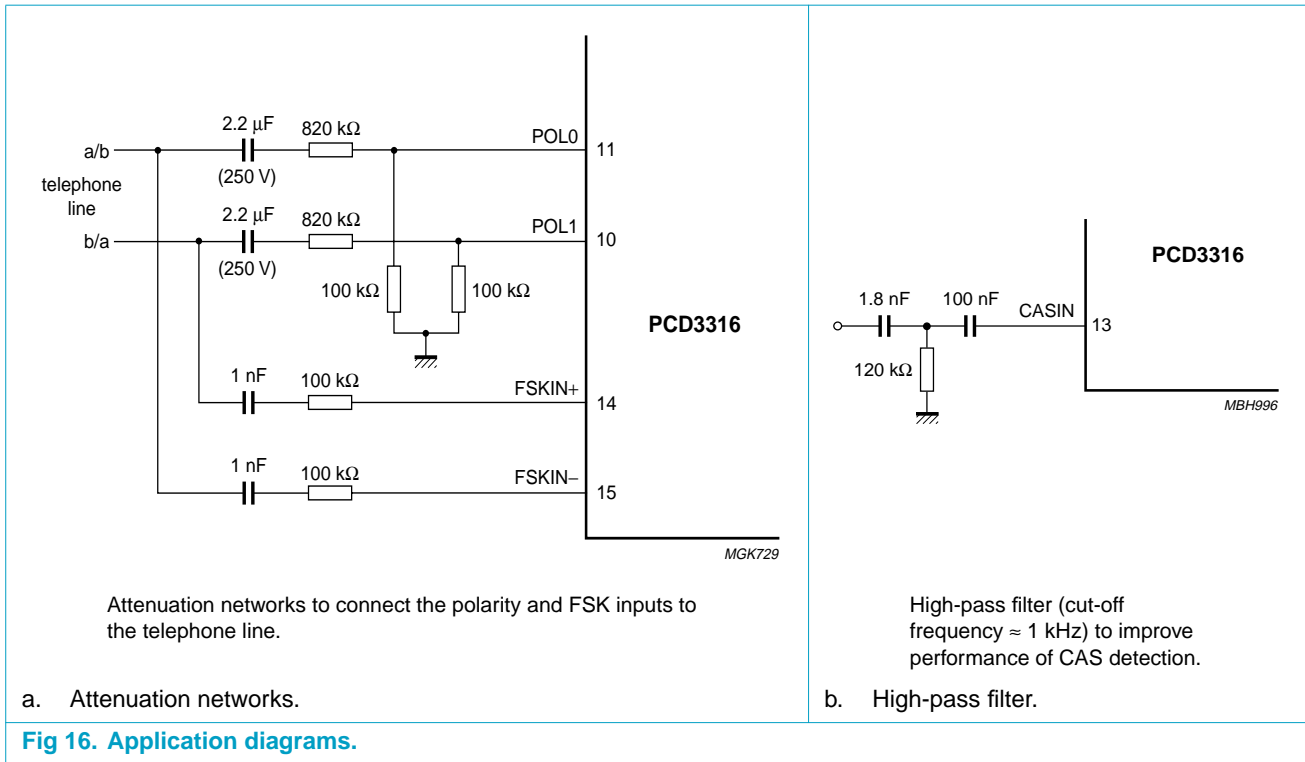

11. Test information

11.1 Application note on Customer Premises Equipment (CPE) testing

Under certain circumstances, some external CIDCW test equipment may generate incorrect pulses after the ringing signal becomes inactive. These pulses may cause the FSK detector of the PCD3316 to respond. Note that this is by no means an incorrect behaviour of the PCD3316 chip, but a correct detection of incorrect test stimuli. However, if not known, it may lead to confusing results during testing of the CPE.

To avoid the issue described above, following work-around can be used:

1. Disable the FSK detection of PCD3316, before and during the ringing signal detection.
2. Switch on the FSK detection only after a certain period, e.g. 100 ms after the ringing signal goes inactive.
3. When the first FSK data is detected, e.g '55H' (possible part of channel seizure), switch off the FSK detection and on again. This will force the FSK detector to resynchronize and detect the normal FSK data correctly. It may be necessary to repeat this sequence a number of times to ensure that the data detected really comes from the channel seizure. Thus, it is recommended to wait for a multiple number of bytes '55H' to be detected to validate a correct channel seizure.

12. Package outline

SO16: plastic small outline package; 16 leads; body width 7.5 mm

SOT162-1

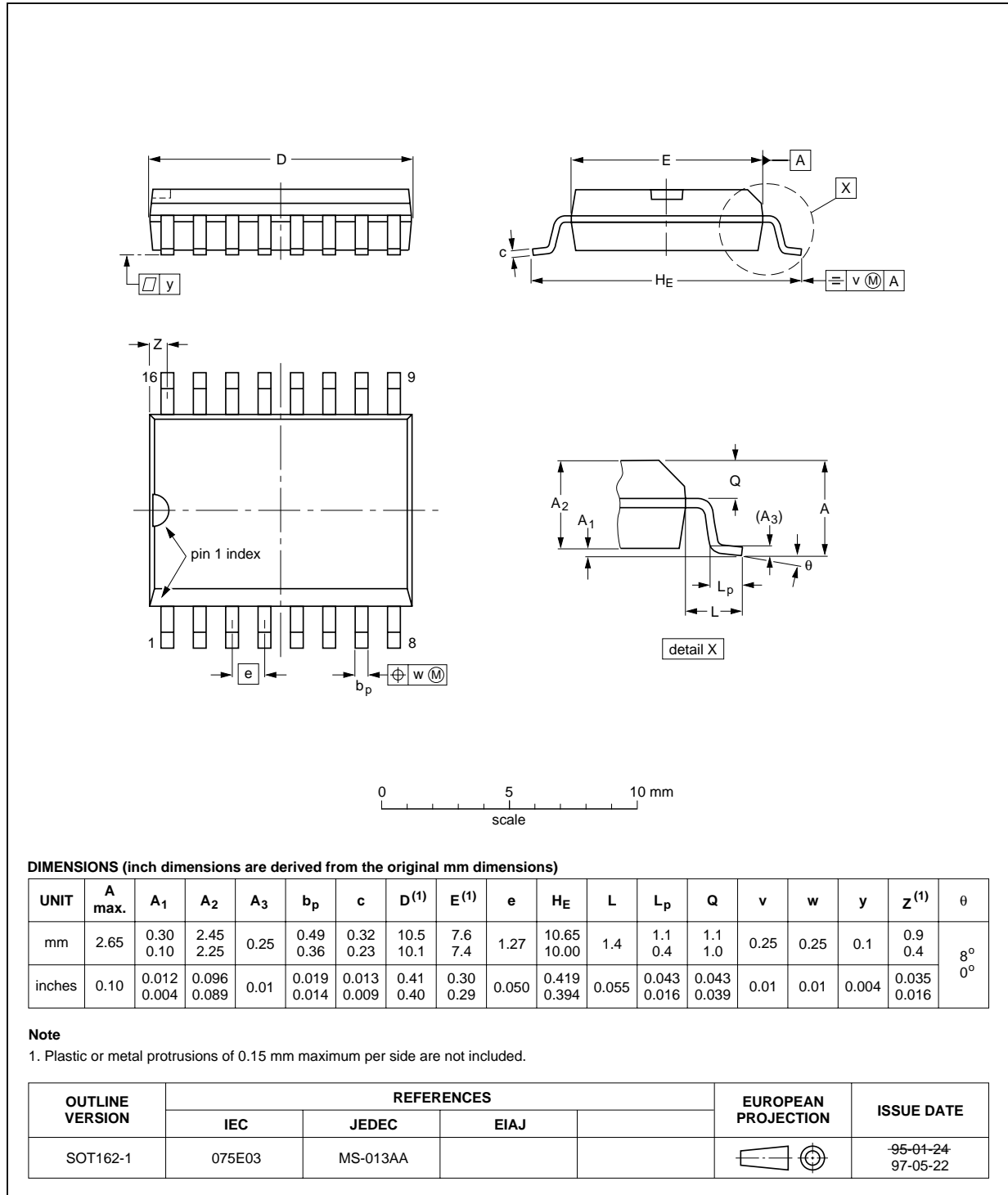

Fig 17. SOT162-1.

13. Soldering

13.1 Introduction to soldering surface mount packages

This text gives a very brief insight to a complex technology. A more in-depth account of soldering ICs can be found in our *Data Handbook IC26; Integrated Circuit Packages* (document order number 9398 652 90011).

There is no soldering method that is ideal for all surface mount IC packages. Wave soldering is not always suitable for surface mount ICs, or for printed-circuit boards with high population densities. In these situations reflow soldering is often used.

13.2 Reflow soldering

Reflow soldering requires solder paste (a suspension of fine solder particles, flux and binding agent) to be applied to the printed-circuit board by screen printing, stencilling or pressure-syringe dispensing before package placement.

Several methods exist for reflowing; for example, infrared/convection heating in a conveyor type oven. Throughput times (preheating, soldering and cooling) vary between 100 and 200 seconds depending on heating method.

Typical reflow peak temperatures range from 215 to 250 °C. The top-surface temperature of the packages should preferably be kept below 230 °C.

13.3 Wave soldering

Conventional single wave soldering is not recommended for surface mount devices (SMDs) or printed-circuit boards with a high component density, as solder bridging and non-wetting can present major problems.

To overcome these problems the double-wave soldering method was specifically developed.

If wave soldering is used the following conditions must be observed for optimal results:

- Use a double-wave soldering method comprising a turbulent wave with high upward pressure followed by a smooth laminar wave.
- For packages with leads on two sides and a pitch (e):
 - larger than or equal to 1.27 mm, the footprint longitudinal axis is **preferred** to be parallel to the transport direction of the printed-circuit board;
 - smaller than 1.27 mm, the footprint longitudinal axis **must** be parallel to the transport direction of the printed-circuit board.

The footprint must incorporate solder thieves at the downstream end.

- For packages with leads on four sides, the footprint must be placed at a 45° angle to the transport direction of the printed-circuit board. The footprint must incorporate solder thieves downstream and at the side corners.

During placement and before soldering, the package must be fixed with a droplet of adhesive. The adhesive can be applied by screen printing, pin transfer or syringe dispensing. The package can be soldered after the adhesive is cured.

Typical dwell time is 4 seconds at 250 °C. A mildly-activated flux will eliminate the need for removal of corrosive residues in most applications.

13.4 Manual soldering

Fix the component by first soldering two diagonally-opposite end leads. Use a low voltage (24 V or less) soldering iron applied to the flat part of the lead. Contact time must be limited to 10 seconds at up to 300 °C.

When using a dedicated tool, all other leads can be soldered in one operation within 2 to 5 seconds between 270 and 320 °C.

13.5 Package related soldering information

Table 19: Suitability of surface mount IC packages for wave and reflow soldering methods

Package	Soldering method	
	Wave	Reflow ^[1]
BGA, SQFP	not suitable	suitable
HLQFP, HSQFP, HSOP, HTSSOP, SMS	not suitable ^[2]	suitable
PLCC, SO, SOJ	suitable	suitable
LQFP, QFP, TQFP	not recommended ^{[3] [4]}	suitable
SSOP, TSSOP, VSO	not recommended ^[5]	suitable

- [1] All surface mount (SMD) packages are moisture sensitive. Depending upon the moisture content, the maximum temperature (with respect to time) and body size of the package, there is a risk that internal or external package cracks may occur due to vaporization of the moisture in them (the so called popcorn effect). For details, refer to the Drypack information in the *Data Handbook IC26; Integrated Circuit Packages; Section: Packing Methods*.
- [2] These packages are not suitable for wave soldering as a solder joint between the printed-circuit board and heatsink (at bottom version) can not be achieved, and as solder may stick to the heatsink (on top version).
- [3] If wave soldering is considered, then the package must be placed at a 45° angle to the solder wave direction. The package footprint must incorporate solder thieves downstream and at the side corners.
- [4] Wave soldering is only suitable for LQFP, QFP and TQFP packages with a pitch (e) equal to or larger than 0.8 mm; it is definitely not suitable for packages with a pitch (e) equal to or smaller than 0.65 mm.
- [5] Wave soldering is only suitable for SSOP and TSSOP packages with a pitch (e) equal to or larger than 0.65 mm; it is definitely not suitable for packages with a pitch (e) equal to or smaller than 0.5 mm.

14. Revision history

Rev	Date	CPCN	Description
01	990311	-	<p>This data sheet supersedes the version of 1998 May 14 (9397 750 03525):</p> <ul style="list-style-type: none">• The format of this specification has been redesigned to comply with Philips Semiconductors' new presentation and information standard• Section 1 "General description" on page 1: reference to application note AN98701 added• Section 7.6 "Level detect" on page 7: Added text regarding the frequency band for signal power measurement• Section 7.10 "3.58 MHz oscillator circuitry" on page 8: recommended resonator indication removed• Section 7.13 "Registers" on page 15: new register presentation in this section• Table 14 "Description of CIDMD1 bits" on page 17: Description of bit CIDMD1.6 and CIDMD1.5 adjusted• Application diagram Figure 16a on page 23: diodes removed• Added Section 11.1 "Application note on Customer Premises Equipment (CPE) testing" on page 23.

Data sheet status

Datasheet status	Product status	Definition ^[1]
Objective specification	Development	This data sheet contains the design target or goal specifications for product development. Specification may change in any manner without notice.
Preliminary specification	Qualification	This data sheet contains preliminary data, and supplementary data will be published at a later date. Philips Semiconductors reserves the right to make changes at any time without notice in order to improve design and supply the best possible product.
Product specification	Production	This data sheet contains final specifications. Philips Semiconductors reserves the right to make changes at any time without notice in order to improve design and supply the best possible product.

[1] Please consult the most recently issued data sheet before initiating or completing a design.

Definitions

Short-form specification — The data in a short-form specification is extracted from a full data sheet with the same type number and title. For detailed information see the relevant data sheet or data handbook.

Limiting values definition — Limiting values given are in accordance with the Absolute Maximum Rating System (IEC 60134). Stress above one or more of the limiting values may cause permanent damage to the device. These are stress ratings only and operation of the device at these or at any other conditions above those given in the Characteristics sections of the specification is not implied. Exposure to limiting values for extended periods may affect device reliability.

Application information — Applications that are described herein for any of these products are for illustrative purposes only. Philips Semiconductors make no representation or warranty that such applications will be suitable for the specified use without further testing or modification.

Disclaimers

Life support — These products are not designed for use in life support appliances, devices, or systems where malfunction of these products can reasonably be expected to result in personal injury. Philips Semiconductors customers using or selling these products for use in such applications do so at their own risk and agree to fully indemnify Philips Semiconductors for any damages resulting from such application.

Right to make changes — Philips Semiconductors reserves the right to make changes, without notice, in the products, including circuits, standard cells, and/or software, described or contained herein in order to improve design and/or performance. Philips Semiconductors assumes no responsibility or liability for the use of any of these products, conveys no licence or title under any patent, copyright, or mask work right to these products, and makes no representations or warranties that these products are free from patent, copyright, or mask work right infringement, unless otherwise specified.

Licenses

Purchase of Philips I²C components



Purchase of Philips I²C components conveys a license under the Philips' I²C patent to use the components in the I²C system provided the system conforms to the I²C specification defined by Philips. This specification can be ordered using the code 9398 393 40011.

Philips Semiconductors - a worldwide company

Argentina: see South America

Australia: Tel. +61 29 805 4455, Fax. +61 29 805 4466

Austria: Tel. +43 160 101, Fax. +43 160 101 1210

Belarus: Tel. +375 17 220 0733, Fax. +375 17 220 0773

Belgium: see The Netherlands

Brazil: see South America

Bulgaria: Tel. +359 268 9211, Fax. +359 268 9102

Canada: Tel. +1 800 234 7381

China/Hong Kong: Tel. +852 2 319 7888, Fax. +852 2 319 7700

Colombia: see South America

Czech Republic: see Austria

Denmark: Tel. +45 3 288 2636, Fax. +45 3 157 0044

Finland: Tel. +358 961 5800, Fax. +358 96 158 0920

France: Tel. +33 14 099 6161, Fax. +33 14 099 6427

Germany: Tel. +49 40 23 5360, Fax. +49 402 353 6300

Greece: Tel. +30 1 489 4339/4239, Fax. +30 1 481 4240

Hungary: see Austria

India: Tel. +91 22 493 8541, Fax. +91 22 493 8722

Indonesia: see Singapore

Ireland: Tel. +353 17 64 0000, Fax. +353 17 64 0200

Israel: Tel. +972 36 45 0444, Fax. +972 36 49 1007

Italy: Tel. +39 26 752 2531, Fax. +39 26 752 2557

Japan: Tel. +81 33 740 5130, Fax. +81 33 740 5077

Korea: Tel. +82 27 09 1412, Fax. +82 27 09 1415

Malaysia: Tel. +60 37 50 5214, Fax. +60 37 57 4880

Mexico: Tel. +9-5 800 234 7381

Middle East: see Italy

Netherlands: Tel. +31 40 278 2785, Fax. +31 40 278 8399

New Zealand: Tel. +64 98 49 4160, Fax. +64 98 49 7811

Norway: Tel. +47 22 74 8000, Fax. +47 22 74 8341

Philippines: Tel. +63 28 16 6380, Fax. +63 28 17 3474

Poland: Tel. +48 22 612 2831, Fax. +48 22 612 2327

Portugal: see Spain

Romania: see Italy

Russia: Tel. +7 095 755 6918, Fax. +7 095 755 6919

Singapore: Tel. +65 350 2538, Fax. +65 251 6500

Slovakia: see Austria

Slovenia: see Italy

South Africa: Tel. +27 11 470 5911, Fax. +27 11 470 5494

South America: Tel. +55 11 821 2333, Fax. +55 11 829 1849

Spain: Tel. +34 33 01 6312, Fax. +34 33 01 4107

Sweden: Tel. +46 86 32 2000, Fax. +46 86 32 2745

Switzerland: Tel. +41 14 88 2686, Fax. +41 14 81 7730

Taiwan: Tel. +886 22 134 2865, Fax. +886 22 134 2874

Thailand: Tel. +66 27 45 4090, Fax. +66 23 98 0793

Turkey: Tel. +90 212 279 2770, Fax. +90 212 282 6707

Ukraine: Tel. +380 44 264 2776, Fax. +380 44 268 0461

United Kingdom: Tel. +44 181 730 5000, Fax. +44 181 754 8421

United States: Tel. +1 800 234 7381

Uruguay: see South America

Vietnam: see Singapore

Yugoslavia: Tel. +381 11 62 5344, Fax. +381 11 63 5777

For all other countries apply to: Philips Semiconductors,
Marketing & Sales Communications,
Building BE, P.O. Box 218, 5600 MD EINDHOVEN,
The Netherlands, Fax. +31 40 272 4825

Internet: <http://www.semiconductors.philips.com>

Contents

1	General description	1
2	Features	2
3	Applications	2
4	Ordering information	2
5	Block diagram	3
6	Pinning information	3
6.1	Pinning	3
6.2	Pin description	4
7	Functional description	4
7.1	Preprocessor and analog inputs	4
7.2	CAS detection	5
7.3	FSK reception	5
7.4	Ring or polarity change detector	6
7.5	Low battery detection	6
7.6	Level detect	7
7.7	Time base	7
7.8	Interrupt	7
7.9	The internal Power-on reset (POR)	8
7.10	3.58 MHz oscillator circuitry	8
7.11	32 kHz oscillator	10
7.12	Serial interface	10
7.12.1	Characteristics of the I ² C-bus	10
7.12.2	START and STOP conditions	11
7.12.3	Bit transfer	11
7.12.4	Acknowledge	11
7.12.5	I ² C-bus protocol	12
7.12.6	I ² C-bus bit rate	14
7.13	Registers	15
7.13.1	Interrupt register (CIDINT)	15
7.13.2	FSK data register (CDFS)	16
7.13.3	Status register (CIDSTA)	16
7.13.4	Ringer period register (CIDRNG)	16
7.13.5	Mode register 1 (CIDMD1)	17
7.13.6	Mode register 2 (CIDMD2)	17
8	Limiting values	18
9	Characteristics	18
10	Application information	22
11	Test information	23
11.1	Application note on Customer Premises Equipment (CPE) testing	23
12	Package outline	24
13	Soldering	25
13.1	Introduction to soldering surface mount packages	25
13.2	Reflow soldering	25
13.3	Wave soldering	25
13.4	Manual soldering	26
13.5	Package related soldering information	26
14	Revision history	27



PHILIPS

Let's make things better.

SUNSTAR 商斯达实业集团是集研发、生产、工程、销售、代理经销、技术咨询、信息服务等为一体的高科技企业，是专业高科技电子产品生产厂家，是具有 10 多年历史的专业电子元器件供应商，是中国最早和最大的仓储式连锁规模经营大型综合电子零部件代理分销商之一，是一家专业代理和分销世界各大品牌 IC 芯片和电子元器件的连锁经营综合性国际公司，专业经营进口、国产名厂名牌电子元件，型号、种类齐全。在香港、北京、深圳、上海、西安、成都等全国主要电子市场设有直属分公司和产品展示展销窗口门市部专卖店及代理分销商，已在全国范围内建成强大统一的供货和代理分销网络。我们专业代理经销、开发生产电子元器件、集成电路、传感器、微波光电元器件、工控机/DOC/DOM 电子盘、专用电路、单片机开发、MCU/DSP/ARM/FPGA 软件硬件、二极管、三极管、模块等，是您可靠的一站式现货配套供应商、方案提供商、部件功能模块开发配套商。商斯达实业公司拥有庞大的资料库，有数位毕业于著名高校——有中国电子工业摇篮之称的西安电子科技大学（西军电）并长期从事国防尖端科技研究的高级工程师为您精挑细选、量身订做各种高科技电子元器件，并解决各种技术问题。

微波光电部专业代理经销高频、微波、光纤、光电元器件、组件、部件、模块、整机；电磁兼容元器件、材料、设备；微波 CAD、EDA 软件、开发测试仿真工具；微波、光纤仪器仪表。欢迎国外高科技微波、光纤厂商将优秀产品介绍到中国、共同开拓市场。长期大量现货专业批发高频、微波、卫星、光纤、电视、CATV 器件：晶振、VCO、连接器、PIN 开关、变容二极管、开关二极管、低噪晶体管、功率电阻及电容、放大器、功率管、MMIC、混频器、耦合器、功分器、振荡器、合成器、衰减器、滤波器、隔离器、环行器、移相器、调制解调器；光电子元件和组件：红外发射管、红外接收管、光电开关、光敏管、发光二极管和发光二极管组件、半导体激光二极管和激光器组件、光电探测器和光接收组件、光发射接收模块、光纤激光器和光放大器、光调制器、光开关、DWDM 用光发射和接收器件、用户接入系统光收发器件与模块、光纤连接器、光纤跳线/尾纤、光衰减器、光纤适配器、光隔离器、光耦合器、光环行器、光复用器/转换器；无线收发芯片和模组、蓝牙芯片和模组。

更多产品请看本公司产品专用销售网站：

商斯达中国传感器科技信息网：<http://www.sensor-ic.com/>

商斯达工控安防网：<http://www.pc-ps.net/>

商斯达电子元器件网：<http://www.sunstare.com/>

商斯达微波光电产品网：[HTTP://www.rfoe.net/](http://www.rfoe.net/)

商斯达消费电子产品网：<http://www.icasic.com/>

商斯达实业科技产品网：<http://www.sunstars.cn/> 微波元器件销售热线：

地址：深圳市福田区福华路福庆街鸿图大厦 1602 室

电话：0755-82884100 83397033 83396822 83398585

传真：0755-83376182 (0) 13823648918 MSN: SUNS8888@hotmail.com

邮编：518033 E-mail:szss20@163.com QQ: 195847376

深圳赛格展销部：深圳华强北路赛格电子市场 2583 号 电话：0755-83665529 25059422

技术支持：0755-83394033 13501568376

欢迎索取免费详细资料、设计指南和光盘；产品凡多，未能尽录，欢迎来电查询。

北京分公司：北京海淀区知春路 132 号中发电子大厦 3097 号

TEL: 010-81159046 82615020 13501189838 FAX: 010-62543996

上海分公司：上海市北京东路 668 号上海赛格电子市场 D125 号

TEL: 021-28311762 56703037 13701955389 FAX: 021-56703037

西安分公司：西安高新开发区 20 所(中国电子科技集团导航技术研究所)

西安劳动南路 88 号电子商城二楼 D23 号

TEL: 029-81022619 13072977981 FAX:029-88789382