

DATA SHEET

TDA9851

**I²C-bus controlled economic BTSC
stereo decoder**

Product specification
File under Integrated Circuits, IC02

1997 Nov 12

I²C-bus controlled economic BTSC stereo decoder

TDA9851

FEATURES

- Voltage Controlled Amplifier (VCA) noise reduction circuit
- Stereo or mono selectable at the AF outputs
- Stereo pilot PLL circuit with ceramic resonator
- Automatic pilot cancellation
- Automatic Volume Level (AVL) control (+6 to –15 dB)
- I²C-bus transceiver.



GENERAL DESCRIPTION

The TDA9851 is a bipolar-integrated BTSC stereo decoder for application in TV sets, VCRs and multimedia PCs.

QUICK REFERENCE DATA

SYMBOL	PARAMETER	CONDITIONS	MIN.	TYP.	MAX.	UNIT
V _{CC}	supply voltage		8	9	9.5	V
I _{CC}	supply current		–	30	40	mA
V _{o(rms)}	output voltage (RMS value)	composite input voltage 250 mV (RMS) for 100% modulation L + R (25 kHz deviation); f _{mod} = 300 Hz	–	500	–	mV
α _{csL,R}	stereo channel separation L and R	14% modulation; f _L = 300 Hz; f _R = 3 kHz	–	20	–	dB
THD _{L,R}	total harmonic distortion L and R	100% modulation L or R; f _{mod} = 1 kHz	–	0.2	1.0	%
S/N	signal-to-noise ratio	mono mode; referenced to 500 mV output signal CCIR 468-2 weighted; quasi peak DIN noise weighting filter (RMS value)	50 –	60 73	– –	dB dBA

ORDERING INFORMATION

TYPE NUMBER	PACKAGE		
	NAME	DESCRIPTION	VERSION
TDA9851	SDIP24	plastic shrink dual in-line package; 24 leads (400 mil)	SOT234-1
TDA9851T	SO24	plastic small outline package; 24 leads; body width 7.5 mm	SOT137-1

I²C-bus controlled economic BTSC stereo decoder

TDA9851

BLOCK DIAGRAM

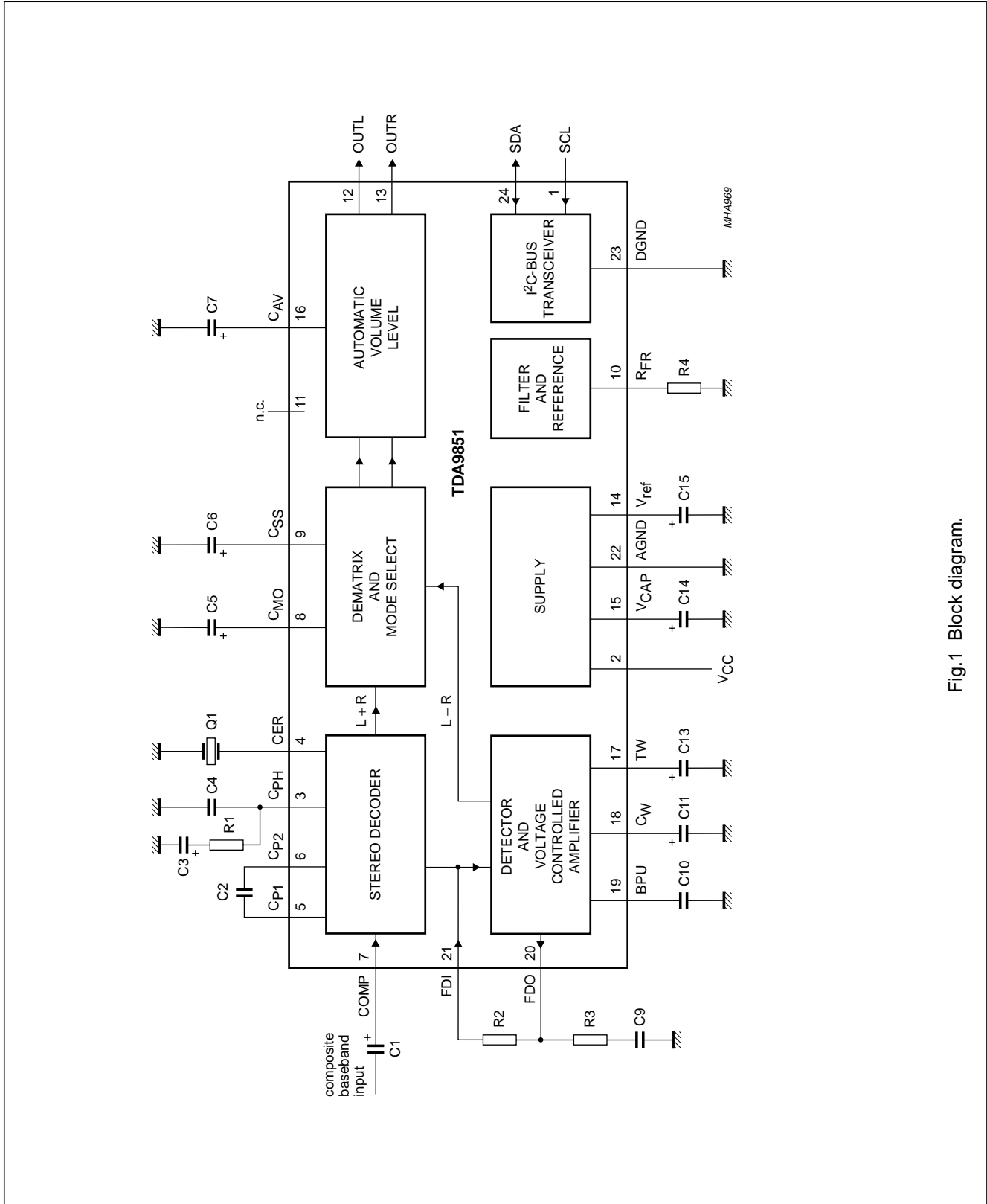

Fig.1 Block diagram.

I²C-bus controlled economic BTSC stereo decoder

TDA9851

Component list

Electrolytic capacitors $\pm 20\%$; foil capacitors $\pm 10\%$; resistors $\pm 5\%$; unless otherwise specified; see Fig.1.

COMPONENT	VALUE	TYPE	REMARK
C1	2.2 μF	electrolytic	63 V
C2	220 nF	foil	
C3	2.2 μF	electrolytic	63 V
C4	220 nF	foil	
C5	2.2 μF	electrolytic	63 V
C6	2.2 μF	electrolytic	63 V
C7	4.7 μF	electrolytic	63 V $\pm 10\%$
C9	22 nF	foil	
C10	4.7 nF	foil	
C11	1 μF	electrolytic	63 V
C13	10 μF	electrolytic	63 V
C14	100 μF	electrolytic	16 V
C15	100 μF	electrolytic	16 V
R1	3.3 k Ω		
R2	15 k Ω		
R3	1.3 k Ω		
R4	100 k Ω		
Q1		CSB503F58	radial leads
		CSB503JF958	alternative as SMD

I²C-bus controlled economic BTSC stereo decoder

TDA9851

PINNING

SYMBOL	PIN	DESCRIPTION
SCL	1	serial clock input (I ² C-bus)
V _{CC}	2	supply voltage
C _{PH}	3	capacitor for phase detector
CER	4	ceramic resonator
C _{P1}	5	capacitor for pilot detector
C _{P2}	6	capacitor for pilot detector
COMP	7	composite input signal
C _{MO}	8	capacitor DC-decoupling mono
C _{SS}	9	capacitor DC-decoupling stereo
R _{FR}	10	resistor for filter reference
n.c.	11	not connected
OUTL	12	output, left channel
OUTR	13	output, right channel
V _{ref}	14	reference voltage 0.5V _{CC}
V _{CAP}	15	capacitor for electronic filtering of supply
C _{AV}	16	automatic volume control capacitor
TW	17	capacitor timing
C _W	18	capacitor for VCA and band-pass filter lower corner frequency
BPU	19	band-pass filter upper corner frequency
FDO	20	fixed de-emphasis output
FDI	21	fixed de-emphasis input
AGND	22	analog ground
DGND	23	digital ground
SDA	24	serial data input/output (I ² C-bus)

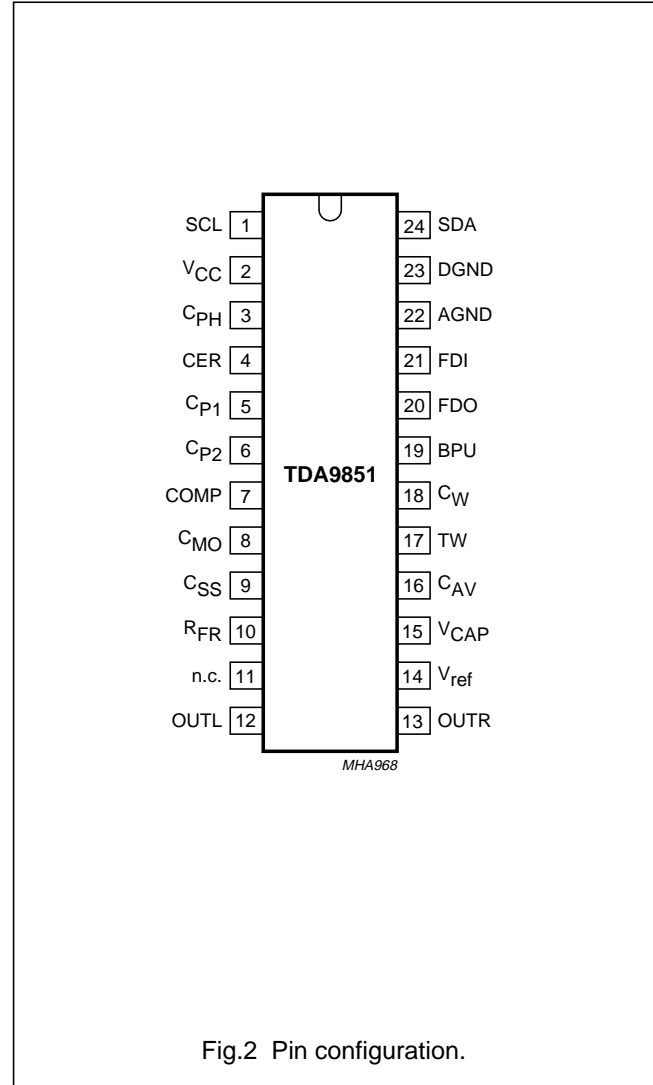

Fig.2 Pin configuration.

I²C-bus controlled economic BTSC stereo decoder

TDA9851

FUNCTIONAL DESCRIPTION

Stereo decoder

The composite signal is fed into a pilot detector/pilot cancellation circuit and into the MPX demodulator. The main L + R signal passes a 75 μ s fixed de-emphasis filter and is fed into the dematrix circuit. The decoded sub-signal L – R is sent to the VCA circuit. To generate the pilot signal the stereo demodulator uses a PLL circuit including a ceramic resonator.

Mode selection

The L – R signal is fed via the internal VCA circuit to the dematrix/switching circuit. Mode selection is achieved via the I²C-bus.

Automatic volume level control

The automatic volume level stage controls its output voltage to a constant level of typically 200 mV (RMS) from

an input voltage range between 0.1 to 1.1 V (RMS). The circuit adjusts variations in modulation during broadcasting and because of changes in the programme material. The function can be switched off. To avoid audible plops during the permanent operation of the AVL circuit a soft blending scheme has been applied between the different gain stages. A capacitor (4.7 μ F) at pin C_{AV} determines the attack and decay time constants. In addition the ratio of attack and decay times can be changed via the I²C-bus.

Integrated filters

The filter functions necessary for stereo demodulation are provided on-chip using transistor circuits. The filter frequencies are controlled by the filter reference circuit via the external resistor R4.

LIMITING VALUES

In accordance with the Absolute Maximum Rating System (IEC 134).

SYMBOL	PARAMETER	CONDITIONS	MIN.	MAX.	UNIT
V _{CC}	supply voltage		0	9.9	V
V _{SDA} , V _{SCL}	voltage of SDA and SCL to GND	V _{CC} < 9 V	0	V _{CC}	V
		V _{CC} ≥ 9 V	0	9	V
V _n	voltage of all other pins to GND		0	V _{CC}	V
T _{amb}	operating ambient temperature	T _j < 125 °C	–20	+70	°C
T _{stg}	storage temperature		–65	+150	°C
V _{es}	electrostatic handling	note 1	–	–	V

Note

- Machine model class B.

THERMAL CHARACTERISTICS

SYMBOL	PARAMETER	CONDITIONS	VALUE	UNIT
R _{th(j-a)}	thermal resistance from junction to ambient	in free air		
	TDA9851 (SOT234-1; SDIP24)		55	K/W
	TDA9851T (SOT137-1; SO24)		90	K/W

I²C-bus controlled economic BTSC stereo decoder

TDA9851

CHARACTERISTICS

All voltages are measured relative to GND; $V_{CC} = 9\text{ V}$; $R_s = 600\ \Omega$; AC-coupled; $R_L = 10\text{ k}\Omega$; $C_L = 2.5\text{ nF}$; $f_{\text{mod}} = 1\text{ kHz}$ mono signal; composite input voltage 250 mV (RMS) for 100% modulation L + R (25 kHz deviation); $T_{\text{amb}} = 25\text{ }^\circ\text{C}$; see Fig.1; unless otherwise specified.

SYMBOL	PARAMETER	CONDITIONS	MIN.	TYP.	MAX.	UNIT
Supply						
V_{CC}	supply voltage		8	9	9.5	V
I_{CC}	supply current		–	30	40	mA
Input stage						
$V_{i(\text{max})(\text{rms})}$	maximum input voltage (RMS value)		2	–	–	V
Z_i	input impedance		20	25	30	k Ω
Stereo decoder						
HR	headroom for L + R, L and R	$f_{\text{mod}} = 300\text{ Hz}$; THD < 15%	9	–	–	dB
$V_{\text{pil}(\text{rms})}$	nominal stereo pilot voltage (RMS value)		–	50	–	mV
$V_{\text{th}(\text{on})(\text{rms})}$	pilot threshold voltage stereo on (RMS value)		–	–	35	mV
$V_{\text{th}(\text{off})(\text{rms})}$	pilot threshold voltage stereo off (RMS value)		15	–	–	mV
hys	hysteresis		–	2.5	–	dB
$V_{o(\text{rms})}$	output voltage (RMS value)	100% modulation L + R; $f_{\text{mod}} = 300\text{ Hz}$	–	500	–	mV
$\alpha_{\text{csL,R}}$	stereo channel separation L and R	14% modulation; $f_L = 300\text{ Hz}$; $f_R = 3\text{ kHz}$	–	20	–	dB
THD _{L,R}	total harmonic distortion L and R	100% modulation L or R; $f_{\text{mod}} = 1\text{ kHz}$	–	0.2	1.0	%
S/N	signal-to-noise ratio	mono mode; referenced to 500 mV output signal CCIR 468-2 weighted; quasi peak DIN noise weighting filter (RMS value)	50 –	60 73	– –	dB dBA
Stereo decoder, oscillator (VCXO); note 1						
f_o	nominal VCXO output frequency ($32f_H$)	with nominal ceramic resonator	–	503.5	–	kHz
Δf_{fr}	spread of free-running frequency	with nominal ceramic resonator	500.0	–	507.0	kHz
Δf_{cr}	capture range frequency	nominal pilot	± 190	± 265	–	Hz

I²C-bus controlled economic BTSC stereo decoder

TDA9851

SYMBOL	PARAMETER	CONDITIONS	MIN.	TYP.	MAX.	UNIT
Outputs OUTL and OUTR						
Z _o	output impedance		–	80	120	Ω
V _O	DC output voltage		0.45V _{CC}	0.5V _{CC}	0.55V _{CC}	V
R _L	output load resistance (AC-coupled)		5	–	–	kΩ
C _L	output load capacitance		–	–	2.5	nF
α _{ct}	crosstalk SAP into L and R	100% modulation; f _{mod} = 1 kHz; SAP; mode selector switched to stereo	50	70	–	dB
VCA						
I _s	nominal timing current for nominal release rate of VCA detector	I _s can be measured at pin TW via current meter connected to 0.5V _{CC} + 1 V	6.5	8	9.5	μA
Rel _{rate}	nominal detector release rate	nominal timing current and external capacitor values	–	125	–	dB/s
Automatic volume level control						
G _v	voltage gain	maximum boost; note 2	5	6	7	dB
		maximum attenuation; note 2	14	15	16	dB
G _{step}	equivalent step width between the input stages (soft switching system)		–	1.5	–	dB
V _{iop(rms)}	input voltage (RMS value)	maximum boost; note 2	–	0.1	–	V
		maximum attenuation; note 2	–	1.125	–	V
V _{o(rms)}	output voltage in AVL operation (RMS value)		160	200	250	mV
V _{offset(DC)}	DC offset voltage between different gain steps	voltage at pin C _{AV} 7.0 to 6.83 V or 6.83 to 6.61 V or 6.61 to 5.83 V or 5.83 to 3.1 V; note 3	–	–	20	mV
R _{att}	discharge resistors for attack time constant	AT1 = 0; AT2 = 0; note 4	340	420	520	Ω
		AT1 = 1; AT2 = 0; note 4	590	730	910	Ω
		AT1 = 0; AT2 = 1; note 4	0.96	1.2	1.5	kΩ
		AT1 = 1; AT2 = 1; note 4	1.7	2.1	2.6	kΩ
I _{dec}	charge current for decay time	normal mode; CCD = 0; note 5	1.6	2.0	2.4	μA
		power-on speed-up; CCD = 1; note 5	–	30	–	μA
Muting at power supply voltage drop for OUTR and OUTL						
ΔV _{CC}	supply voltage drop for mute active		–	V _{CAP} – 0.7	–	V

I²C-bus controlled economic BTSC stereo decoder

TDA9851

SYMBOL	PARAMETER	CONDITIONS	MIN.	TYP.	MAX.	UNIT
Power-on reset; note 6						
V _{POR(start)}	start of reset voltage	increasing supply voltage	–	–	2.5	V
		decreasing supply voltage	4.2	5	5.8	V
V _{POR(end)}	end of reset voltage	increasing supply voltage	5.2	6	6.8	V
Digital part (I²C-bus pins); note 7						
V _{IH}	HIGH-level input voltage		3	–	V _{CC} ≤ 9	V
V _{IL}	LOW-level input voltage		–0.3	–	+1.5	V
I _{IH}	HIGH-level input current		–10	–	+10	μA
I _{IL}	LOW-level input current		–10	–	+10	μA
V _{OL}	LOW-level output voltage	I _{IL} = 3 mA	–	–	0.4	V

Notes to the characteristics

- The oscillator is designed to operate together with Murata resonator CSB503F58 or CSB503JF958 as SMD. Change of the resonator supplier is possible, but the resonator specification must be close to the specified ones.
- The AVL input voltage is internal. It corresponds to the output voltage OUTL and OUTR at AVL off.
- The listed pin voltage corresponds with typical gain steps of +6 dB, +3 dB, 0 dB, –6 dB and –15 dB.
- Attack time constant = C_{CAV} × R_{att}.

$$5. \text{ Decay time} = \frac{C_{CAV} \times 0.76 \text{ V} \left(10^{\frac{-G_1}{20}} - 10^{\frac{-G_2}{20}} \right)}{I_{dec}}$$

Example: C_{CAV} = 4.7 μF; I_{dec} = 2 μA; G₁ = –9 dB; G₂ = +6 dB → decay time results in 4.14 s.

- When reset is active the GMU bit (mute) is set and the I²C-bus receiver is in the reset position.
- The AC characteristics are in accordance with the I²C-bus specification for standard mode (clock frequency maximum 100 kHz). A higher frequency, up to 280 kHz, can be used if all clock and data times are interpolated between standard mode (100 kHz) and fast mode (400 kHz) in accordance with the I²C-bus specification. Information about the I²C-bus can be found in brochure "I²C-bus and how to use it" (order number 9398 393 40011).

I²C-bus controlled economic BTSC stereo decoder

TDA9851

I²C-BUS PROTOCOL

I²C-bus format to read (slave transmits data)

S	SLAVE ADDRESS	R/ \overline{W}	A	DATA	P
---	---------------	-------------------	---	------	---

Table 1 Explanation of I²C-bus format to read (slave transmits data)

NAME	DESCRIPTION
S	START condition; generated by the master
Standard SLAVE ADDRESS (MAD)	101 101 1
R/ \overline{W}	logic 1 (read); generated by the master
A	acknowledge; generated by the slave
DATA	slave transmits an 8-bit data word
P	STOP condition; generated by the master

Table 2 Definition of the transmitted bytes after read condition

MSB							LSB
D7	D6	D5	D4	D3	D2	D1	D0
Y	Y	Y	Y	Y	Y	Y	STP

Table 3 Function of the bits in Table 2

BITS	FUNCTION
STP	stereo pilot identification (stereo received = 1)
Y	indefinite

I²C-bus format to write (slave receives data)

S	SLAVE ADDRESS	R/ \overline{W}	A	DATA	A	P
---	---------------	-------------------	---	------	---	---

Table 4 Explanation of I²C-bus format to write (slave receives data)

NAME	DESCRIPTION
S	START condition
Standard SLAVE ADDRESS (MAD)	101 101 1
R/ \overline{W}	logic 0 (write)
A	acknowledge; generated by the slave
DATA	see Table 5
P	STOP condition

Table 5 Definition of the DATA (second byte after MAD)

MSB							LSB
D7	D6	D5	D4	D3	D2	D1	D0
0	0	AT2	AT1	CCD	AVLON	GMU	STEREO

I²C-bus controlled economic BTSC stereo decoder

TDA9851

Table 6 Function of the bits in Table 5

BITS	FUNCTION
STEREO	mode selection stereo or mono
GMU	mute control OUTL and OTR
AVLON	AVL on/off
CCD	increased AVL decay current on/off
AT1 and AT2	attack time at AVL

Table 7 Mode setting

FUNCTION MODE		READABLE BIT STP	SETTING BIT STEREO
OUTL	OTR		
Left	right	1 (stereo received)	1
Mono	mono	1 (stereo received)	0
Mono	mono	0 (no stereo received)	1
Mono	mono	0 (no stereo received)	0

Table 8 Mute setting

FUNCTION	DATA GMU
Forced mute at OTR and OUTL	1
No forced mute at OTR and OUTL	0

Table 9 AVLON bit setting

FUNCTION	DATA
Automatic volume control on	1
Automatic volume control off	0

Table 10 CCD bit setting

FUNCTION	DATA
Load current for normal AVL decay time	0
Increased load current	1

Table 11 AVL attack time

R _{att} (Ω)	DATA	
	AT1	AT2
420	0	0
730	1	0
1200	0	1
2100	1	1

I²C-bus controlled economic BTSC stereo decoder

TDA9851

INTERNAL PIN CONFIGURATIONS

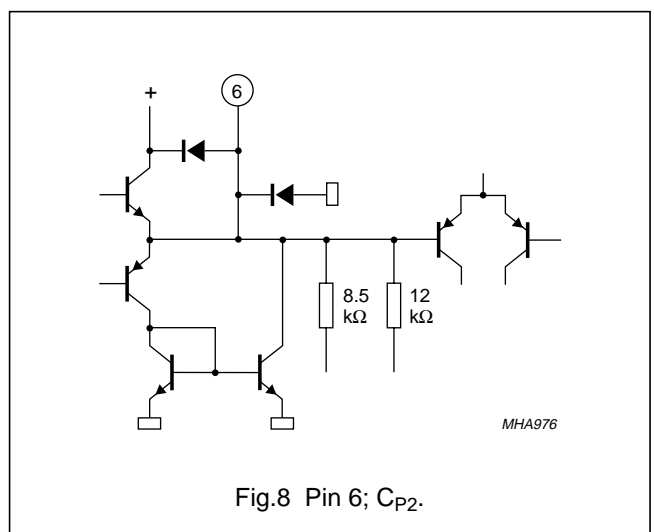
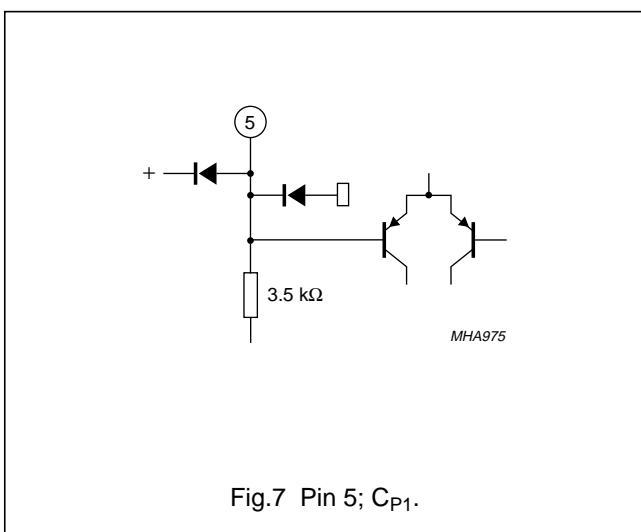
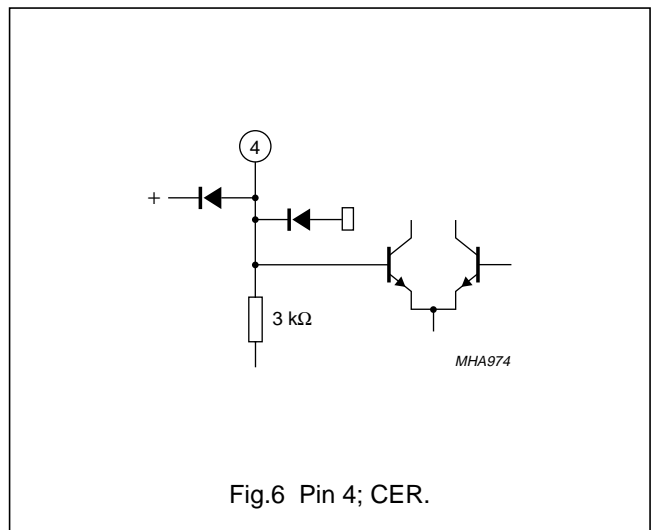
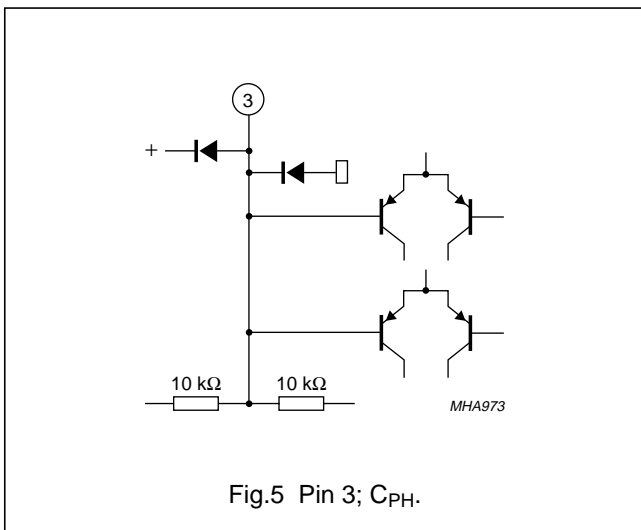
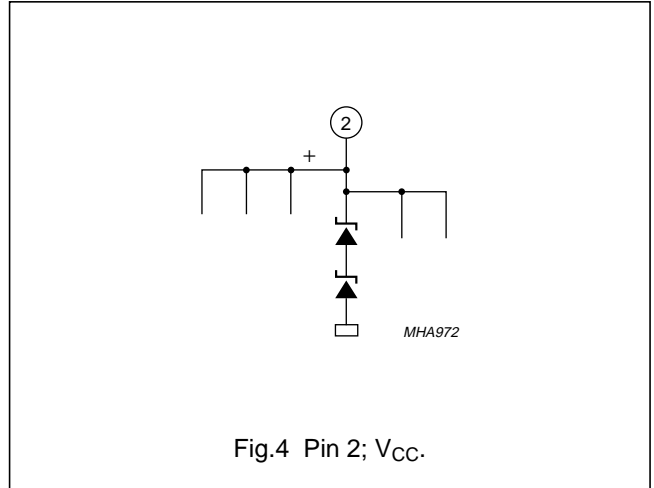
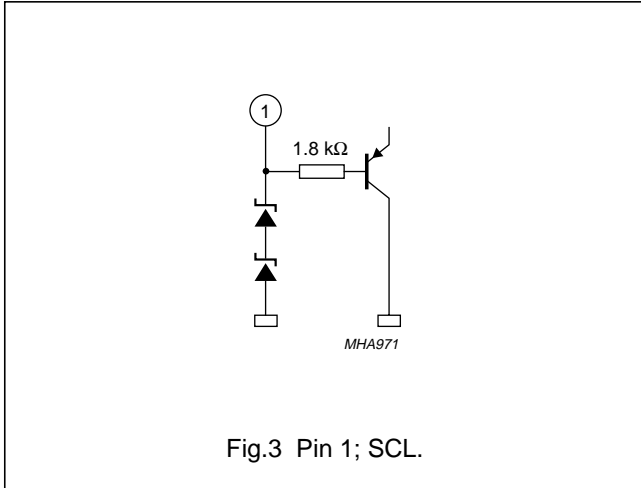

I²C-bus controlled economic BTSC stereo decoder

TDA9851

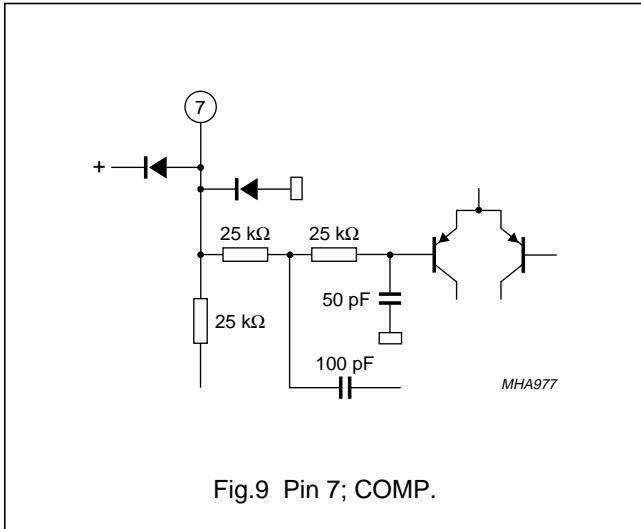

Fig.9 Pin 7; COMP.

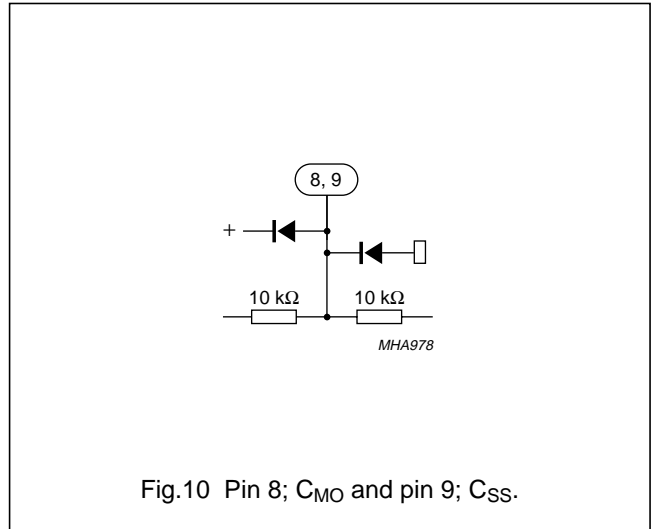

Fig.10 Pin 8; C_{MO} and pin 9; C_{SS}.

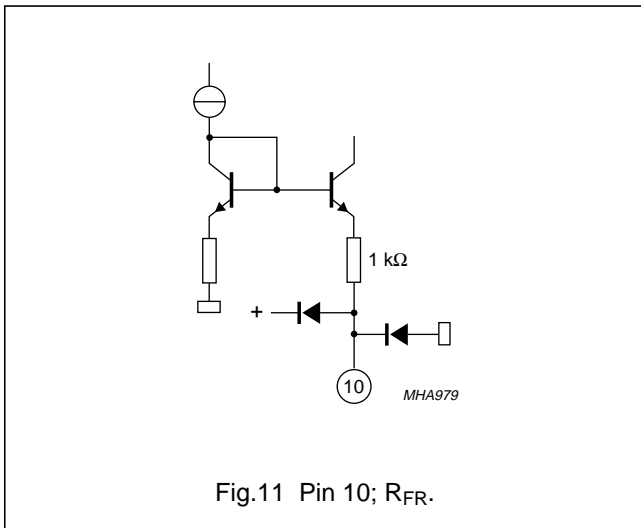

Fig.11 Pin 10; R_{FR}.

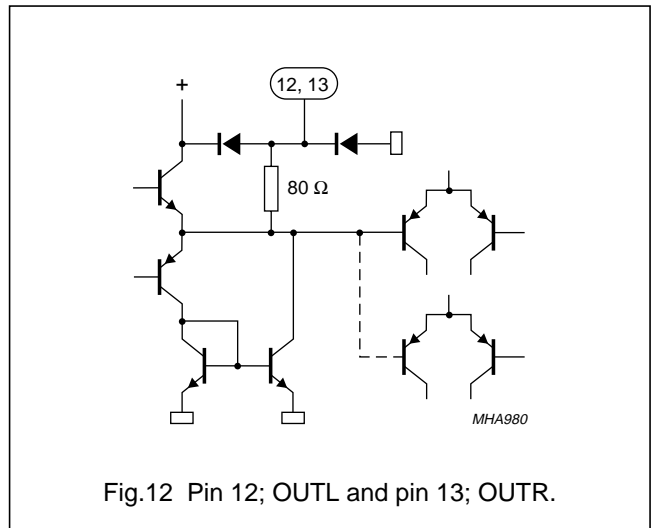

Fig.12 Pin 12; OUTL and pin 13; OUTR.

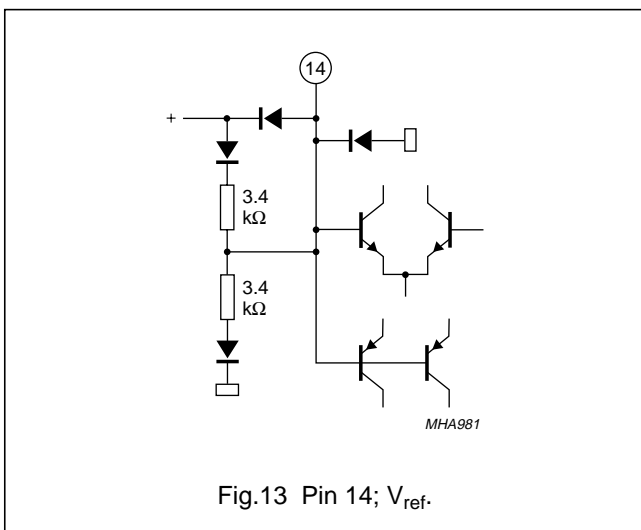

Fig.13 Pin 14; V_{ref}.

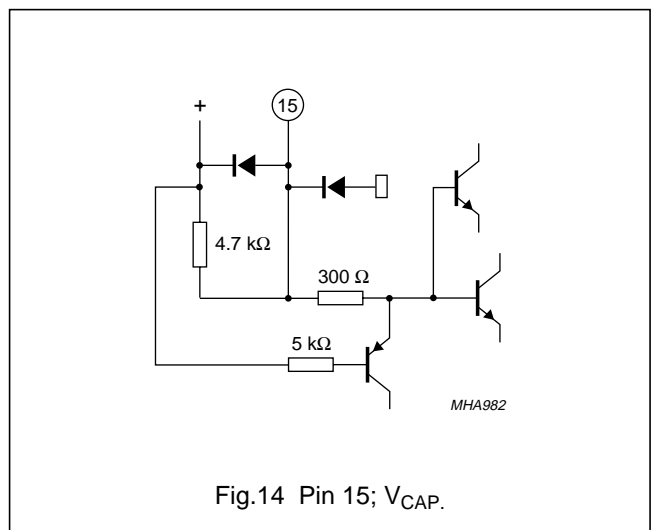

Fig.14 Pin 15; V_{CAP}.

I²C-bus controlled economic BTSC stereo decoder

TDA9851

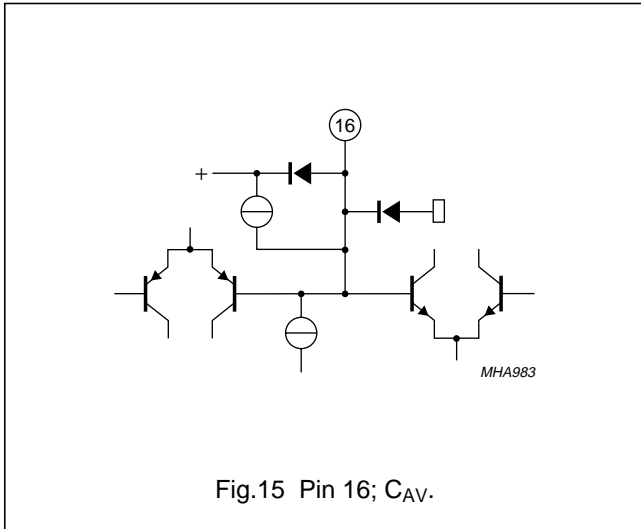

Fig.15 Pin 16; CAV.

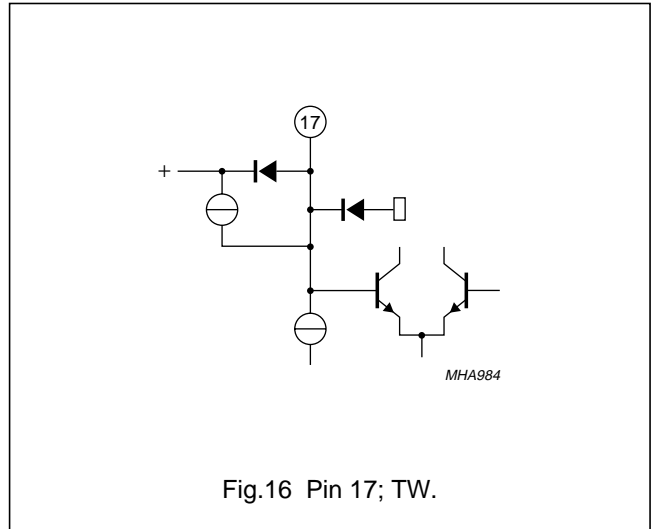

Fig.16 Pin 17; TW.

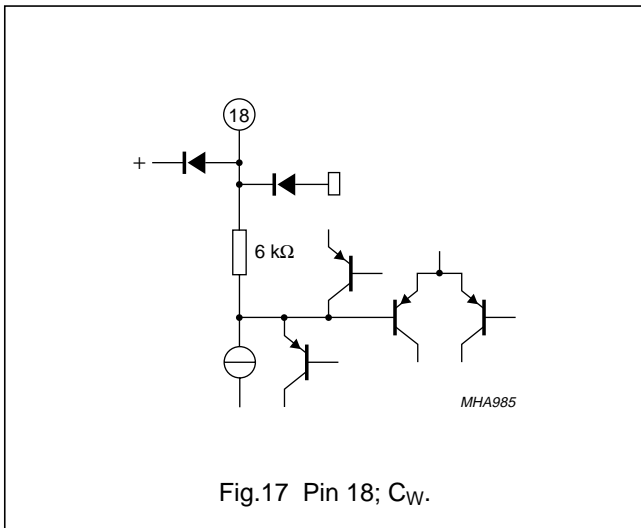

Fig.17 Pin 18; CW.

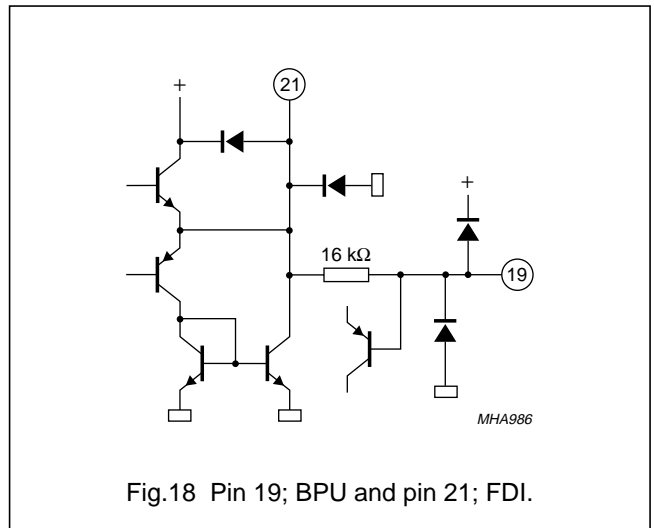

Fig.18 Pin 19; BPU and pin 21; FDI.

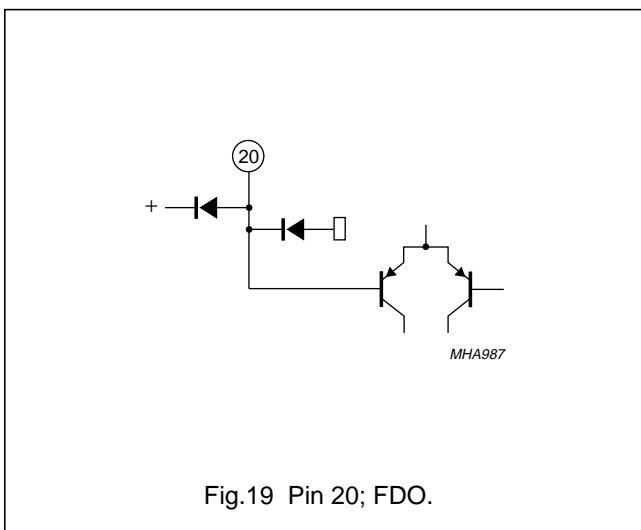

Fig.19 Pin 20; FDO.

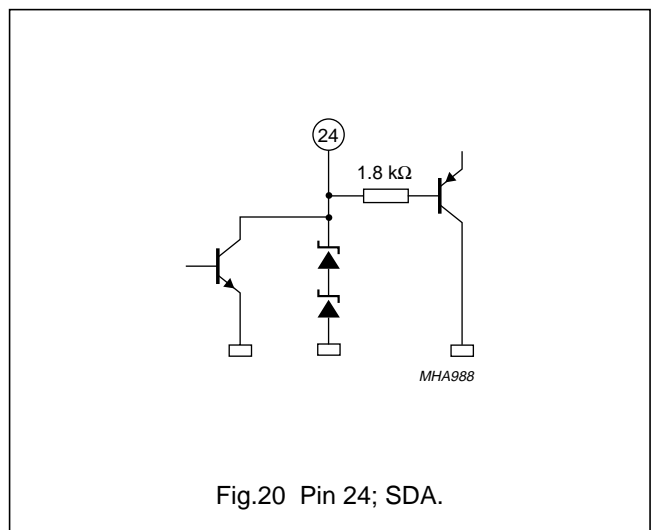

Fig.20 Pin 24; SDA.

I²C-bus controlled economic BTSC stereo decoder

TDA9851

APPLICATION INFORMATION

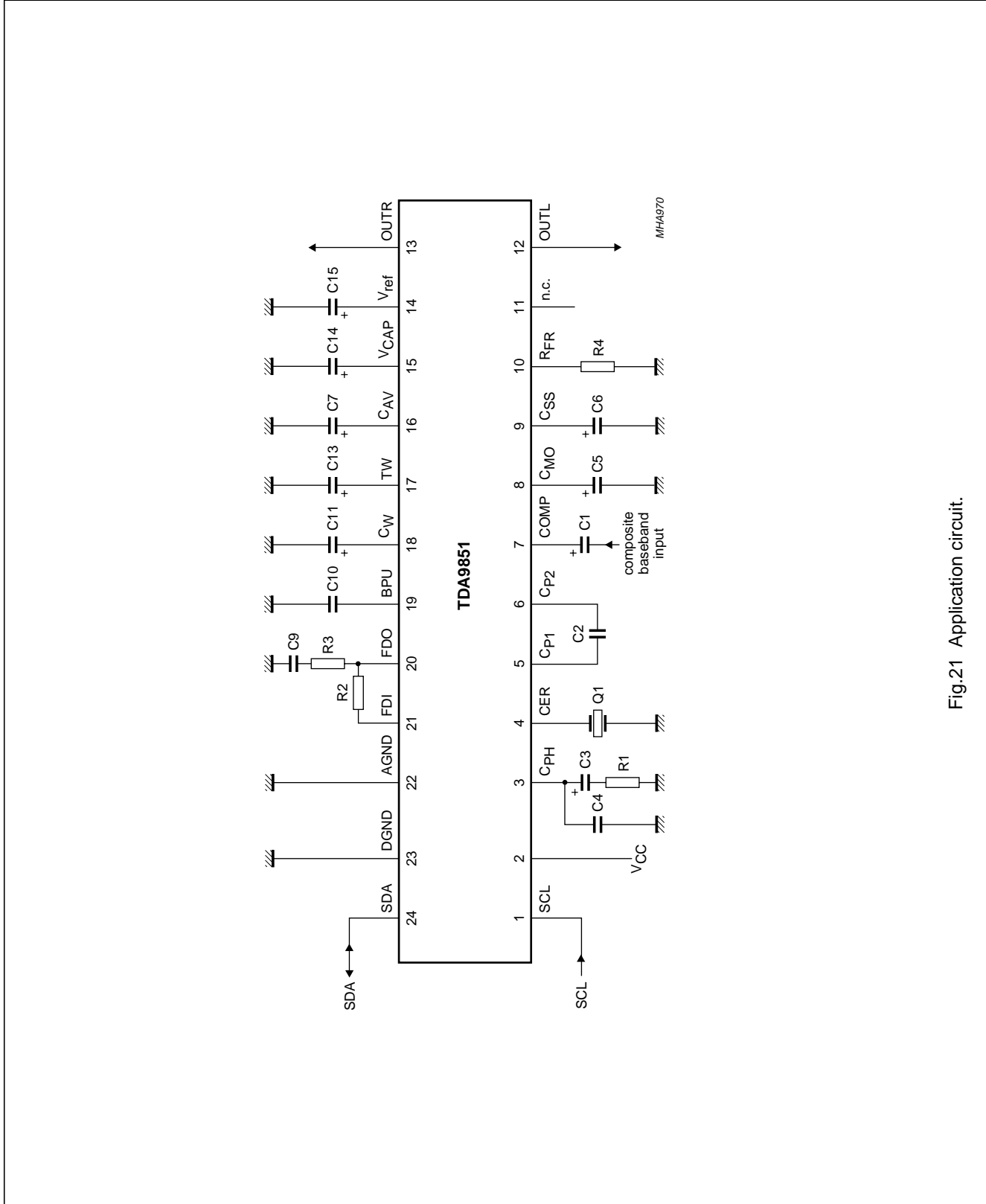

Fig.21 Application circuit.

I²C-bus controlled economic BTSC stereo decoder

TDA9851

PACKAGE OUTLINES

SDIP24: plastic shrink dual in-line package; 24 leads (400 mil)

SOT234-1

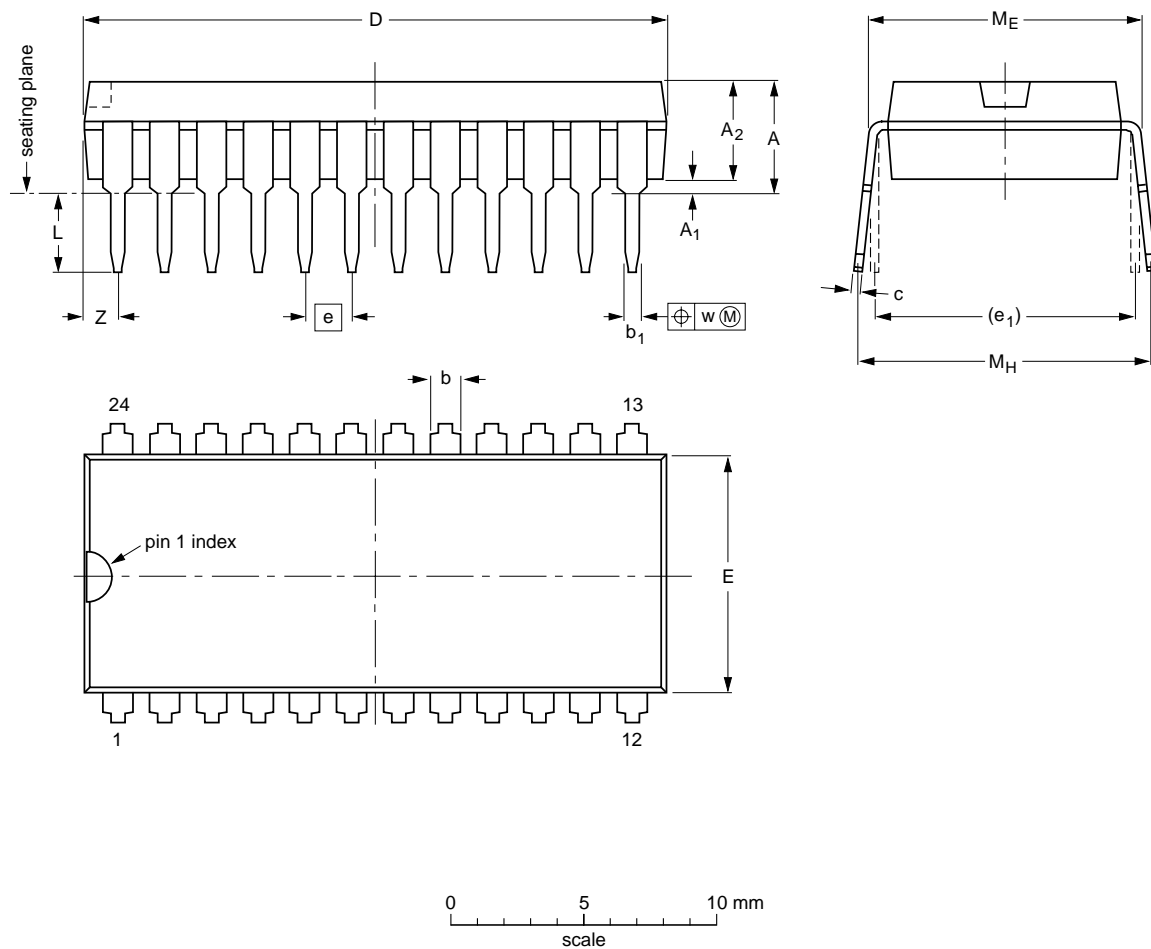

DIMENSIONS (mm are the original dimensions)

UNIT	A max.	A ₁ min.	A ₂ max.	b	b ₁	c	D ⁽¹⁾	E ⁽¹⁾	e	e ₁	L	M _E	M _H	w	Z ⁽¹⁾ max.
mm	4.7	0.51	3.8	1.3 0.8	0.53 0.40	0.32 0.23	22.3 21.4	9.1 8.7	1.778	10.16	3.2 2.8	10.7 10.2	12.2 10.5	0.18	1.6

Note

1. Plastic or metal protrusions of 0.25 mm maximum per side are not included.

OUTLINE VERSION	REFERENCES				EUROPEAN PROJECTION	ISSUE DATE
	IEC	JEDEC	EIAJ			
SOT234-1						92-11-17 95-02-04

I²C-bus controlled economic BTSC stereo decoder

TDA9851

SO24: plastic small outline package; 24 leads; body width 7.5 mm

SOT137-1

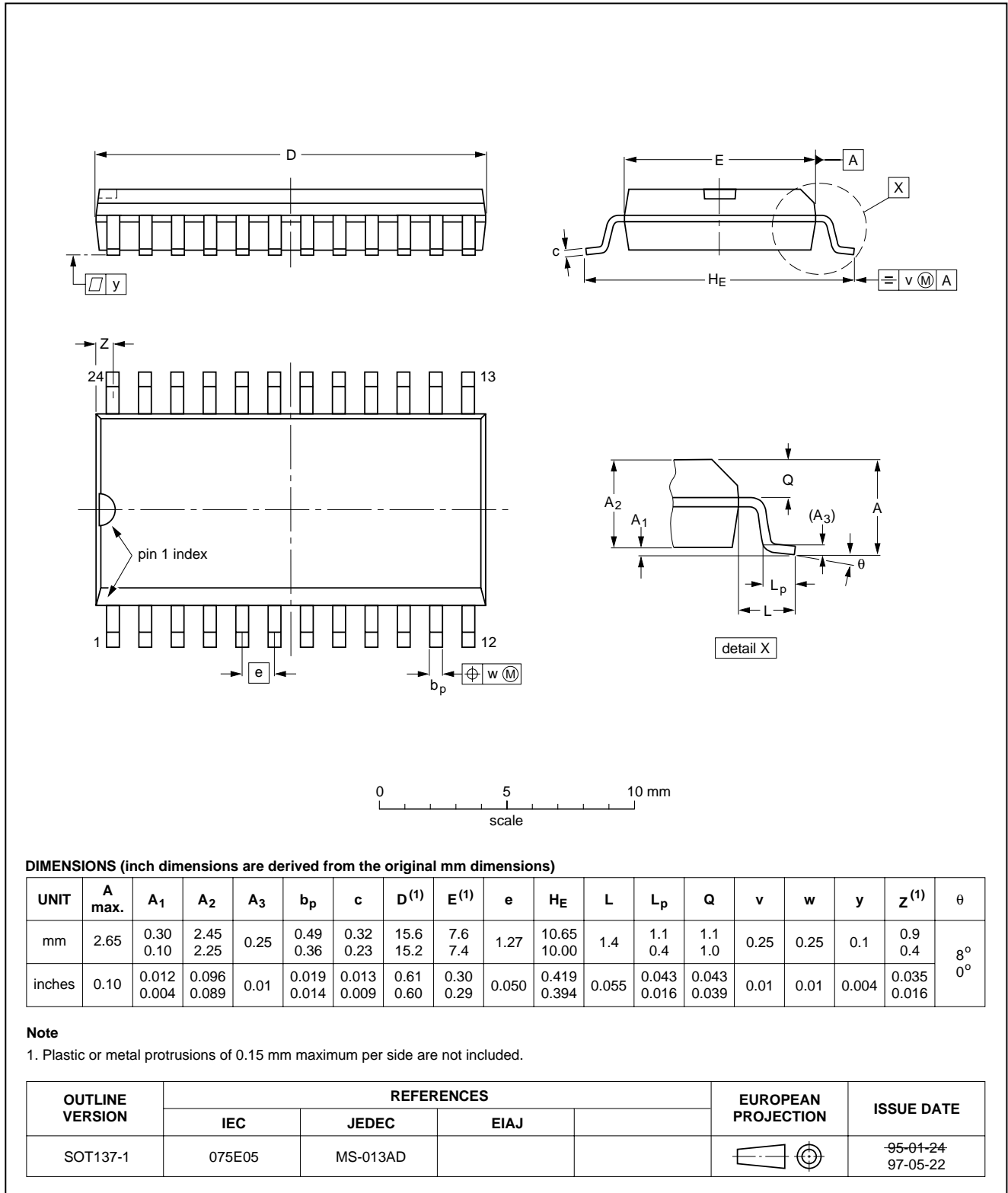

I²C-bus controlled economic BTSC stereo decoder

TDA9851

SOLDERING

Introduction

There is no soldering method that is ideal for all IC packages. Wave soldering is often preferred when through-hole and surface mounted components are mixed on one printed-circuit board. However, wave soldering is not always suitable for surface mounted ICs, or for printed-circuits with high population densities. In these situations reflow soldering is often used.

This text gives a very brief insight to a complex technology. A more in-depth account of soldering ICs can be found in our "IC Package Databook" (order code 9398 652 90011).

SDIP

SOLDERING BY DIPPING OR BY WAVE

The maximum permissible temperature of the solder is 260 °C; solder at this temperature must not be in contact with the joint for more than 5 seconds. The total contact time of successive solder waves must not exceed 5 seconds.

The device may be mounted up to the seating plane, but the temperature of the plastic body must not exceed the specified maximum storage temperature ($T_{stg\ max}$). If the printed-circuit board has been pre-heated, forced cooling may be necessary immediately after soldering to keep the temperature within the permissible limit.

REPAIRING SOLDERED JOINTS

Apply a low voltage soldering iron (less than 24 V) to the lead(s) of the package, below the seating plane or not more than 2 mm above it. If the temperature of the soldering iron bit is less than 300 °C it may remain in contact for up to 10 seconds. If the bit temperature is between 300 and 400 °C, contact may be up to 5 seconds.

SO

REFLOW SOLDERING

Reflow soldering techniques are suitable for all SO packages.

Reflow soldering requires solder paste (a suspension of fine solder particles, flux and binding agent) to be applied to the printed-circuit board by screen printing, stencilling or pressure-syringe dispensing before package placement.

Several techniques exist for reflowing; for example, thermal conduction by heated belt. Dwell times vary between 50 and 300 seconds depending on heating method. Typical reflow temperatures range from 215 to 250 °C.

Preheating is necessary to dry the paste and evaporate the binding agent. Preheating duration: 45 minutes at 45 °C.

WAVE SOLDERING

Wave soldering techniques can be used for all SO packages if the following conditions are observed:

- A double-wave (a turbulent wave with high upward pressure followed by a smooth laminar wave) soldering technique should be used.
- The longitudinal axis of the package footprint must be parallel to the solder flow.
- The package footprint must incorporate solder thieves at the downstream end.

During placement and before soldering, the package must be fixed with a droplet of adhesive. The adhesive can be applied by screen printing, pin transfer or syringe dispensing. The package can be soldered after the adhesive is cured.

Maximum permissible solder temperature is 260 °C, and maximum duration of package immersion in solder is 10 seconds, if cooled to less than 150 °C within 6 seconds. Typical dwell time is 4 seconds at 250 °C.

A mildly-activated flux will eliminate the need for removal of corrosive residues in most applications.

REPAIRING SOLDERED JOINTS

Fix the component by first soldering two diagonally-opposite end leads. Use only a low voltage soldering iron (less than 24 V) applied to the flat part of the lead. Contact time must be limited to 10 seconds at up to 300 °C. When using a dedicated tool, all other leads can be soldered in one operation within 2 to 5 seconds between 270 and 320 °C.

I²C-bus controlled economic BTSC stereo decoder

TDA9851

DEFINITIONS

Data sheet status	
Objective specification	This data sheet contains target or goal specifications for product development.
Preliminary specification	This data sheet contains preliminary data; supplementary data may be published later.
Product specification	This data sheet contains final product specifications.
Limiting values	
Limiting values given are in accordance with the Absolute Maximum Rating System (IEC 134). Stress above one or more of the limiting values may cause permanent damage to the device. These are stress ratings only and operation of the device at these or at any other conditions above those given in the Characteristics sections of the specification is not implied. Exposure to limiting values for extended periods may affect device reliability.	
Application information	
Where application information is given, it is advisory and does not form part of the specification.	

LIFE SUPPORT APPLICATIONS

These products are not designed for use in life support appliances, devices, or systems where malfunction of these products can reasonably be expected to result in personal injury. Philips customers using or selling these products for use in such applications do so at their own risk and agree to fully indemnify Philips for any damages resulting from such improper use or sale.

PURCHASE OF PHILIPS I²C COMPONENTS



Purchase of Philips I²C components conveys a license under the Philips' I²C patent to use the components in the I²C system provided the system conforms to the I²C specification defined by Philips. This specification can be ordered using the code 9398 393 40011.

Philips Semiconductors – a worldwide company

Argentina: see South America

Australia: 34 Waterloo Road, NORTH RYDE, NSW 2113,
Tel. +61 2 9805 4455, Fax. +61 2 9805 4466

Austria: Computerstr. 6, A-1101 WIEN, P.O. Box 213, Tel. +43 160 1010,
Fax. +43 160 101 1210

Belarus: Hotel Minsk Business Center, Bld. 3, r. 1211, Volodarski Str. 6,
220050 MINSK, Tel. +375 172 200 733, Fax. +375 172 200 773

Belgium: see The Netherlands

Brazil: see South America

Bulgaria: Philips Bulgaria Ltd., Energoproject, 15th floor,
51 James Bourchier Blvd., 1407 SOFIA,
Tel. +359 2 689 211, Fax. +359 2 689 102

Canada: PHILIPS SEMICONDUCTORS/COMPONENTS,
Tel. +1 800 234 7381

China/Hong Kong: 501 Hong Kong Industrial Technology Centre,
72 Tat Chee Avenue, Kowloon Tong, HONG KONG,
Tel. +852 2319 7888, Fax. +852 2319 7700

Colombia: see South America

Czech Republic: see Austria

Denmark: Prags Boulevard 80, PB 1919, DK-2300 COPENHAGEN S,
Tel. +45 32 88 2636, Fax. +45 31 57 0044

Finland: Sinikalliontie 3, FIN-02630 ESPOO,
Tel. +358 9 615800, Fax. +358 9 61580920

France: 4 Rue du Port-aux-Vins, BP317, 92156 SURESNES Cedex,
Tel. +33 1 40 99 6161, Fax. +33 1 40 99 6427

Germany: Hammerbrookstraße 69, D-20097 HAMBURG,
Tel. +49 40 23 53 60, Fax. +49 40 23 536 300

Greece: No. 15, 25th March Street, GR 17778 TAVROS/ATHENS,
Tel. +30 1 4894 339/239, Fax. +30 1 4814 240

Hungary: see Austria

India: Philips INDIA Ltd, Band Box Building, 2nd floor,
254-D, Dr. Annie Besant Road, Worli, MUMBAI 400 025,
Tel. +91 22 493 8541, Fax. +91 22 493 0966

Indonesia: see Singapore

Ireland: Newstead, Clonskeagh, DUBLIN 14,
Tel. +353 1 7640 000, Fax. +353 1 7640 200

Israel: RAPAC Electronics, 7 Kehilat Saloniki St, PO Box 18053,
TEL AVIV 61180, Tel. +972 3 645 0444, Fax. +972 3 649 1007

Italy: PHILIPS SEMICONDUCTORS, Piazza IV Novembre 3,
20124 MILANO, Tel. +39 2 6752 2531, Fax. +39 2 6752 2557

Japan: Philips Bldg 13-37, Kohnan 2-chome, Minato-ku, TOKYO 108,
Tel. +81 3 3740 5130, Fax. +81 3 3740 5077

Korea: Philips House, 260-199 Itaewon-dong, Yongsan-ku, SEOUL,
Tel. +82 2 709 1412, Fax. +82 2 709 1415

Malaysia: No. 76 Jalan Universiti, 46200 PETALING JAYA, SELANGOR,
Tel. +60 3 750 5214, Fax. +60 3 757 4880

Mexico: 5900 Gateway East, Suite 200, EL PASO, TEXAS 79905,
Tel. +9-5 800 234 7381

Middle East: see Italy

Netherlands: Postbus 90050, 5600 PB EINDHOVEN, Bldg. VB,
Tel. +31 40 27 82785, Fax. +31 40 27 88399

New Zealand: 2 Wagener Place, C.P.O. Box 1041, AUCKLAND,
Tel. +64 9 849 4160, Fax. +64 9 849 7811

Norway: Box 1, Manglerud 0612, OSLO,
Tel. +47 22 74 8000, Fax. +47 22 74 8341

Philippines: Philips Semiconductors Philippines Inc.,
106 Valero St. Salcedo Village, P.O. Box 2108 MCC, MAKATI,
Metro MANILA, Tel. +63 2 816 6380, Fax. +63 2 817 3474

Poland: Ul. Lukiska 10, PL 04-123 WARSZAWA,
Tel. +48 22 612 2831, Fax. +48 22 612 2327

Portugal: see Spain

Romania: see Italy

Russia: Philips Russia, Ul. Usatcheva 35A, 119048 MOSCOW,
Tel. +7 095 755 6918, Fax. +7 095 755 6919

Singapore: Lorong 1, Toa Payoh, SINGAPORE 1231,
Tel. +65 350 2538, Fax. +65 251 6500

Slovakia: see Austria

Slovenia: see Italy

South Africa: S.A. PHILIPS Pty Ltd., 195-215 Main Road Martindale,
2092 JOHANNESBURG, P.O. Box 7430 Johannesburg 2000,
Tel. +27 11 470 5911, Fax. +27 11 470 5494

South America: Rua do Rocio 220, 5th floor, Suite 51,
04552-903 São Paulo, SÃO PAULO - SP, Brazil,
Tel. +55 11 821 2333, Fax. +55 11 829 1849

Spain: Balmes 22, 08007 BARCELONA,
Tel. +34 3 301 6312, Fax. +34 3 301 4107

Sweden: Kottbygatan 7, Akalla, S-16485 STOCKHOLM,
Tel. +46 8 632 2000, Fax. +46 8 632 2745

Switzerland: Allmendstrasse 140, CH-8027 ZÜRICH,
Tel. +41 1 488 2686, Fax. +41 1 481 7730

Taiwan: Philips Semiconductors, 6F, No. 96, Chien Kuo N. Rd., Sec. 1,
TAIPEI, Taiwan Tel. +886 2 2134 2865, Fax. +886 2 2134 2874

Thailand: PHILIPS ELECTRONICS (THAILAND) Ltd.,
209/2 Sanpavuth-Bangna Road Prakanong, BANGKOK 10260,
Tel. +66 2 745 4090, Fax. +66 2 398 0793

Turkey: Talatpasa Cad. No. 5, 80640 GÜLTEPE/ISTANBUL,
Tel. +90 212 279 2770, Fax. +90 212 282 6707

Ukraine: PHILIPS UKRAINE, 4 Patrice Lumumba str., Building B, Floor 7,
252042 KIEV, Tel. +380 44 264 2776, Fax. +380 44 268 0461

United Kingdom: Philips Semiconductors Ltd., 276 Bath Road, Hayes,
MIDDLESEX UB3 5BX, Tel. +44 181 730 5000, Fax. +44 181 754 8421

United States: 811 East Arques Avenue, SUNNYVALE, CA 94088-3409,
Tel. +1 800 234 7381

Uruguay: see South America

Vietnam: see Singapore

Yugoslavia: PHILIPS, Trg N. Pasica 5/v, 11000 BEOGRAD,
Tel. +381 11 625 344, Fax. +381 11 635 777

For all other countries apply to: Philips Semiconductors, Marketing & Sales Communications,
Building BE-p, P.O. Box 218, 5600 MD EINDHOVEN, The Netherlands, Fax. +31 40 27 24825

Internet: <http://www.semiconductors.philips.com>

© Philips Electronics N.V. 1997

SCA55

All rights are reserved. Reproduction in whole or in part is prohibited without the prior written consent of the copyright owner.

The information presented in this document does not form part of any quotation or contract, is believed to be accurate and reliable and may be changed without notice. No liability will be accepted by the publisher for any consequence of its use. Publication thereof does not convey nor imply any license under patent- or other industrial or intellectual property rights.

Printed in The Netherlands

547047/1200/01/pp20

Date of release: 1997 Nov 12

Document order number: 9397 750 02702

Let's make things better.

Philips
Semiconductors



PHILIPS

SUNSTAR 商斯达实业集团是集研发、生产、工程、销售、代理经销、技术咨询、信息服务等为一体的高科技企业，是专业高科技电子产品生产厂家，是具有 10 多年历史的专业电子元器件供应商，是中国最早和最大的仓储式连锁规模经营大型综合电子零部件代理分销商之一，是一家专业代理和分销世界各大品牌 IC 芯片和电子元器件的连锁经营综合性国际公司，专业经营进口、国产名厂名牌电子元件，型号、种类齐全。在香港、北京、深圳、上海、西安、成都等全国主要电子市场设有直属分公司和产品展示展销窗口门市部专卖店及代理分销商，已在全国范围内建成强大统一的供货和代理分销网络。我们专业代理经销、开发生产电子元器件、集成电路、传感器、微波光电元器件、工控机/DOC/DOM 电子盘、专用电路、单片机开发、MCU/DSP/ARM/FPGA 软件硬件、二极管、三极管、模块等，是您可靠的一站式现货配套供应商、方案提供商、部件功能模块开发配套商。商斯达实业公司拥有庞大的资料库，有数位毕业于著名高校——有中国电子工业摇篮之称的西安电子科技大学（西军电）并长期从事国防尖端科技研究的高级工程师为您精挑细选、量身订做各种高科技电子元器件，并解决各种技术问题。

微波光电部专业代理经销高频、微波、光纤、光电元器件、组件、部件、模块、整机；电磁兼容元器件、材料、设备；微波 CAD、EDA 软件、开发测试仿真工具；微波、光纤仪器仪表。欢迎国外高科技微波、光纤厂商将优秀产品介绍到中国、共同开拓市场。长期大量现货专业批发高频、微波、卫星、光纤、电视、CATV 器件：晶振、VCO、连接器、PIN 开关、变容二极管、开关二极管、低噪晶体管、功率电阻及电容、放大器、功率管、MMIC、混频器、耦合器、功分器、振荡器、合成器、衰减器、滤波器、隔离器、环行器、移相器、调制解调器；光电子元件和组件：红外发射管、红外接收管、光电开关、光敏管、发光二极管和发光二极管组件、半导体激光二极管和激光器组件、光电探测器和光接收组件、光发射接收模块、光纤激光器和光放大器、光调制器、光开关、DWDM 用光发射和接收器件、用户接入系统光收发器件与模块、光纤连接器、光纤跳线/尾纤、光衰减器、光纤适配器、光隔离器、光耦合器、光环行器、光复用器/转换器；无线收发芯片和模组、蓝牙芯片和模组。

更多产品请看本公司产品专用销售网站：

商斯达中国传感器科技信息网：<http://www.sensor-ic.com/>

商斯达工控安防网：<http://www.pc-ps.net/>

商斯达电子元器件网：<http://www.sunstare.com/>

商斯达微波光电产品网：[HTTP://www.rfoe.net/](http://www.rfoe.net/)

商斯达消费电子产品网：<http://www.icasic.com/>

商斯达实业科技产品网：<http://www.sunstars.cn/> 微波元器件销售热线：

地址：深圳市福田区福华路福庆街鸿图大厦 1602 室

电话：0755-82884100 83397033 83396822 83398585

传真：0755-83376182 (0) 13823648918 MSN: SUNS8888@hotmail.com

邮编：518033 E-mail:szss20@163.com QQ: 195847376

深圳赛格展销部：深圳华强北路赛格电子市场 2583 号 电话：0755-83665529 25059422

技术支持：0755-83394033 13501568376

欢迎索取免费详细资料、设计指南和光盘；产品凡多，未能尽录，欢迎来电查询。

北京分公司：北京海淀区知春路 132 号中发电子大厦 3097 号

TEL: 010-81159046 82615020 13501189838 FAX: 010-62543996

上海分公司：上海市北京东路 668 号上海赛格电子市场 D125 号

TEL: 021-28311762 56703037 13701955389 FAX: 021-56703037

西安分公司：西安高新开发区 20 所(中国电子科技集团导航技术研究所)

西安劳动南路 88 号电子商城二楼 D23 号

TEL: 029-81022619 13072977981 FAX:029-88789382