

SECTION 17

MOUNTING AND SOLDERING

contents	page
INTRODUCTION	17 - 2
AXIAL AND RADIAL LEADED DEVICES	17 - 2
Handling	17 - 2
Soldering	17 - 2
Mounting	17 - 3
SURFACE-MOUNT DEVICES	17 - 3
Reflow soldering process	17 - 3
Double-wave soldering process	17 - 7
Hand soldering of microminiature components	17- 11
Assessment of soldered joint quality	17 - 11
Footprint definitions	17 - 13
Recommended footprints	17 - 14

Small-signal and Medium-power Diodes

Mounting and soldering

INTRODUCTION

There are two basic forms of electronic component construction, those with leads for through-hole mounting and microminiature types for surface mounting. Through-hole mounting gives a very rugged construction and uses well established soldering methods. Surface mounting has the advantages of high packing density plus high-speed automated assembly.

AXIAL AND RADIAL LEADED DEVICES

The following general rules are for the safe handling and soldering of axial and radial leaded diodes. Special rules for particular types may apply and, for these, instructions are given in the individual data sheets. With all components, excessive forces or heat can cause serious damage and should always be avoided.

Handling

- Avoid perpendicular forces on the body of the diode
- Avoid sudden forces on the leads or body. These forces are often much greater than allowed
- Avoid high acceleration as a result of any shock, e.g. dropping the device on a hard surface
- During bending, support the leads between body or stud and the bending point
- During the bending process, axial forces on the body must not exceed 20 N
- Bending the leads through 90° is allowed at any distance from the body when it is possible to support the leads during bending without contacting the body or weldings
- Bending close to the body or stud without supporting the leads is only allowed if the bend radius is greater than 0.5 mm
- Twisting the leads is allowed at any distance from the body or stud only if the lead is properly clamped between body or stud and the twisting point
- Without clamping, twisting the leads is allowed only at a distance of greater than 3 mm from the body; the torque angle must not exceed 30°
- Straightening bent leads is allowed only if the applied pulling force in the axial direction does not exceed 20 N and the total pull duration is not longer than 5 s.

Soldering

- Avoid any force on the body or leads during or immediately after soldering
- Do not correct the position of an already soldered device by pushing, pulling or twisting the body
- Avoid fast cooling after soldering.

The maximum allowable soldering time is determined by:

- Package type
- Mounting environment
- Soldering method
- Soldering temperature
- Distance between the point of soldering and the seal of the diode body.

Table 1 shows the minimum distances from soldering point to body seal for components that are mounted on a printed-wiring board with soldering performed by hand-held soldering tool, dip, wave or other solder bath method. The maximum soldering temperature is 300 °C, and the maximum soldering time is 5 s.

Table 1 Distance from soldering point to body seal

PACKAGE	MINIMUM DISTANCE (mm)
SOD27 (DO-35)	0.5
SOD57	0.5
SOD61	2.0
SOD64	0.5
SOD66 (DO-41)	3.0
SOD68 (DO-34)	0.5
SOD81	0.5
SOD83A	0.5
SOD88A	0.5
SOD91	0.5
SOT18/15 (TO-18)	0.5

When soldering is performed by a hand-held soldering tool on components mounted on anything other than a printed-wiring board, the minimum distance from body seal to the soldering point at a maximum soldering temperature of 300 °C is stated in Table 1 but the maximum soldering time must be reduced to 3 s.

Small-signal and Medium-power Diodes

Mounting and soldering

Mounting

If the rules for handling and soldering are observed, the following mounting or process methods are allowed:

- Preheating of the printed-wiring board before soldering up to a maximum of 100 °C
- Flat mounting with the diode body in direct contact with the printed-wiring board with or without metal tracks on both sides and/or plated-through holes
- Flat mounting with the diode body in direct contact with hot spots or hot tracks during soldering
- Upright mounting with the diode body in direct contact with the printed-wiring board if the body is not in contact with metal tracks or plated-through holes.

SURFACE-MOUNT DEVICES

Since the introduction of Surface Mount Devices (SMDs), component design and manufacturing techniques have changed almost beyond recognition. Smaller pitch, minimum footprint area and reduced component volume all contribute to a more compact circuit assembly. As a consequence, when designing printed circuit boards (PCBs), the dimensions of the footprints are perhaps more crucial than ever before.

One of the first steps in this design process is to consider which soldering method, either wave or reflow, will be used during production. This determines not only the solder footprint dimensions, but also the minimum spacing between components, the available area underneath the component where tracks may be laid, and possibly the required component orientation during soldering.

Although reflow soldering is recommended for SMDs, many manufacturers use, and will continue to use for some time to come, a mixture of surface-mount and through-hole components on one substrate (a mixed print).

The mix of components affects the soldering methods that can be applied. A substrate having SMDs mounted on one or both sides but no through-hole components is likely to be suitable for reflow or wave soldering. A double sided mixed print that has through-hole components and some SMDs on one side and densely packed SMDs on the other normally undergoes a sequential combination of reflow and wave soldering. When the mixed print has only through-hole components on one side and all SMDs on the other, wave soldering is usually applied.

To help with your circuit board design, this guideline gives an overview of both reflow and wave soldering methods, and is followed by some useful hints on hand soldering for

repair purposes, and the recommended footprints for our SMD discrete semiconductor packages.

Reflow soldering process

There are three basic process steps for single-sided PCB reflow soldering, these are:

1. Applying solder paste to the PCB
2. Component placement
3. Reflow soldering.

APPLYING SOLDER PASTE TO THE PCB

Solder paste can be applied to the PCBs solder lands by one of either three methods: dispensing, screen or stencil printing.

Dispensing is flexible but is slow, and only suitable for pitches of 0.65 mm and above.

With screen printing, a fine-mesh screen is placed over the PCB and the solder paste is forced through the mesh onto the solder lands of the PCB. However, because of mesh aperture limitations (emulsion resolution), this method is only suitable for solder paste deposits of 300 µm and wider.

Stencil printing is similar to screen printing, except that a metal stencil is used instead of a fine-mesh screen. The stencil is usually made of stainless steel or bronze and should be 150 to 200 µm thick. A squeegee is passed across the stencil to force solder paste through the apertures in the stencil and onto the solder lands on the PCB (see Fig.1). It does not suffer from the same limitations as the other two printing methods and so is the preferred method currently available.

It is recommended that for solder paste printing, the equipment is located in a controlled environment maintained at a temperature of 23 ± 2 °C, and a relative humidity between 45% and 75%.

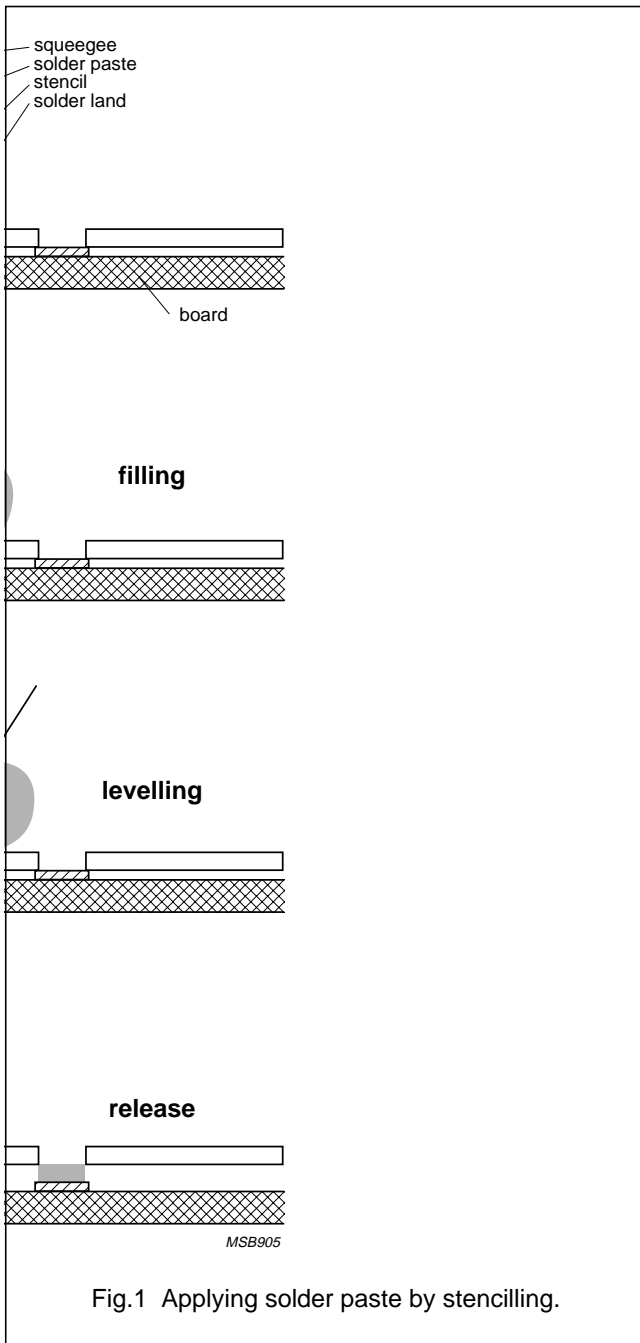

Fig.1 Applying solder paste by stencilling.

Stencil printing

The printing process must be able to apply the solder paste deposits to the PCB:

- In the correct amounts
- At the correct position on the lands
- With an acceptable height and shape.

The amount of solder paste used must be sufficient to give reliable soldered joints. This amount is controlled by the stencil thickness, aperture dimensions, process settings, and the volume of paste pressed through the apertures by the squeegee.

The downward force of the squeegee is counteracted by the hydrodynamic pressure of the paste, and so the machine should be set to ensure that the stencil is just 'cleaned' by the squeegee.

Suitable aperture dimensions depend on the stencil thickness. The solder paste deposits must have a flat part on the top (Fig.2, examples 4 and 5), which can be achieved by correct process settings. The footprints given in this book were designed for these correct deposit types. Stencil apertures that are too small result in irregular dots on the lands (Fig.2, examples 1 to 3). If the apertures are too large, solder paste can be scooped out, particularly if a rubber squeegee is used (Fig.2, example 6).

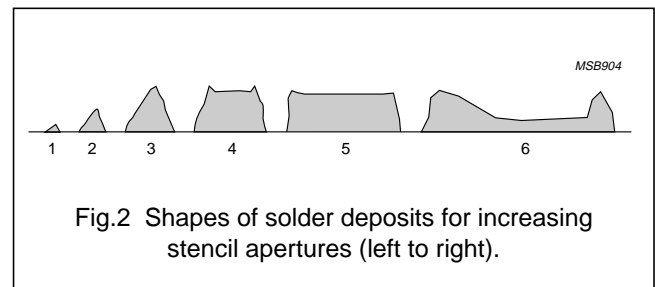

Fig.2 Shapes of solder deposits for increasing stencil apertures (left to right).

Ideally, the deposited solder paste should sit entirely on the solder land. The tolerated misplacement of solder paste with respect to the solder land is determined by the most critical component. The solder paste deposit must be deposited within 100 µm with respect to the solder land.

Furthermore, the tackiness (tack strength) of the solder paste must be sufficient to hold surface-mount devices on the PCB during assembly and during transport to the reflow oven. Tack strength depends on factors such as paste composition, drying conditions, placement pressure, dwell time and contact area. As a general rule, component placement should be within four hours after the paste printing process.

Squeegee

The squeegee can be either metal or rubber. A metal squeegee gives better overall results and so is recommended, however with step stencils, a rubber squeegee has to be used. The footprints given in this chapter were designed for application by both types of squeegee.

Small-signal and Medium-power Diodes

Mounting and soldering

Stencil apertures

Stencil apertures can be made by either:

- Etching
- Laser cutting
- Electroforming.

Of the three methods, etching is less accurate as the deviation in aperture dimensions with respect to the target is relatively large (target is +50 µm at squeegee side and 0 µm at PCB side).

Laser-cut and electroformed stencils have smaller deviations in dimensions and are therefore more suitable for small and fine-pitch components (see Fig.3).

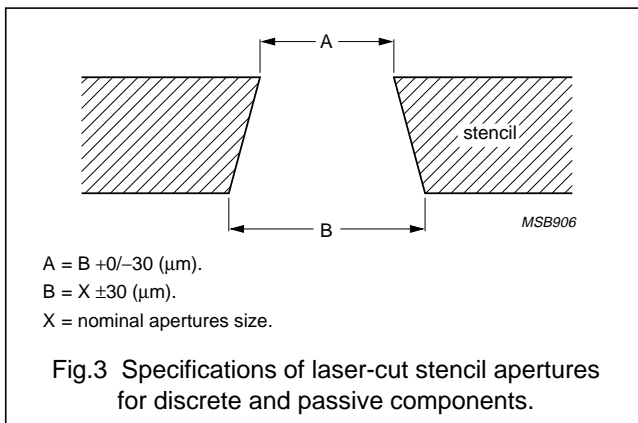

A useful method of controlling the stencil printing process during production is by monitoring the weight of solder paste on the board which may vary between 80% and 110% of the theoretical amount according to the target (designed) apertures. Smearing and clogging of a small aperture cannot be detected with this method.

Solder paste

Reflow soldering uses a paste consisting of small nodules of solder and a flux with binder, solvents and additives to control rheological properties. The flux in the solder paste can be rosin mildly activated or rosin activated.

The requirements of the solder paste are:

- Good rolling behaviour
- No slump during heat-up
- Low viscosity during printing
- High viscosity after printing
- Sufficient tackiness to hold the components
- Removal of oxides during reflow soldering.

Suitable solder paste types have the following compositions:

- Sn62Pb36Ag2
- Sn63Pb37
- Sn60Pb40.

COMPONENT PLACEMENT

The position of the component with respect to the solder lands is an important factor in the final result of the assembly process. A misaligned component can lead to unreliable joints, open circuits and/or bridges between leads.

The placement accuracy is defined as the maximum permissible deviation of the component outline or component leads, with respect to the actual position of the solder land pattern belonging to that component or component leads on the circuit board (see Fig.4).

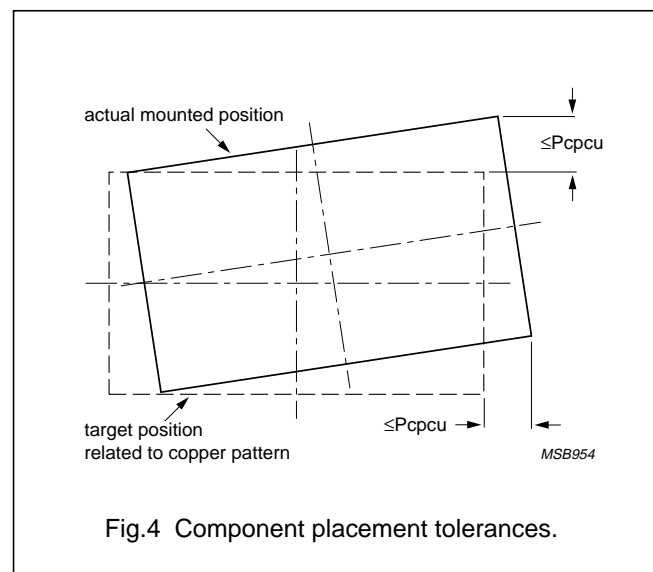

A maximum placement deviation (P) of 0.25 mm is used in these guidelines, which relates to the accuracy of a low-end placement machine. A higher placement accuracy is required for components with a fine pitch. This is given in the footprint description for the components concerned.

Besides the position in x- and y-directions, the z-position with respect to the solder paste, which is determined by the placement force, is also important. If the placement force is too high, solder paste will be squeezed out and solder balls or bridges will be formed. If the force is too low, physical contact will be insufficient, leads will not be soldered properly and the component may shift.

Small-signal and Medium-power Diodes

Mounting and soldering

REFLOW SOLDERING

There are several methods available to provide the heat to reflow the solder paste, such as convection, hot belt, hot gas, vapour phase and resistance soldering. The preferred method is, however, convection reflow.

Convection reflow

With this method, the PCBs passes through an oven where it is preheated, reflow soldered and cooled (see Fig.5). If the heating rate of the board and components are similar, however, preheating is not necessary.

During the reflow soldering process, all parts of the board must be subjected to an accurate temperature/ time profile. Figure 5 shows a suitable profile framework for

single-sided reflow soldering and the first side of double-sided print boards. It's important to note that this profile is for discrete semiconductor packages. The actual framework for the entire PCB could be smaller than the one shown, as other components on the board may have different process requirements.

Reflow soldering can be done in either air or a nitrogen atmosphere. If soldering in air, the temperature (T_p) must not exceed 240 °C on the first side of a double-sided print board with organic coated solder lands. This is because peak temperatures greater than 240 °C reduce the solderability of the lands on the second side to be soldered. This peak temperature can rise to 280 °C when soldering the second side with organic coated solder lands in air.

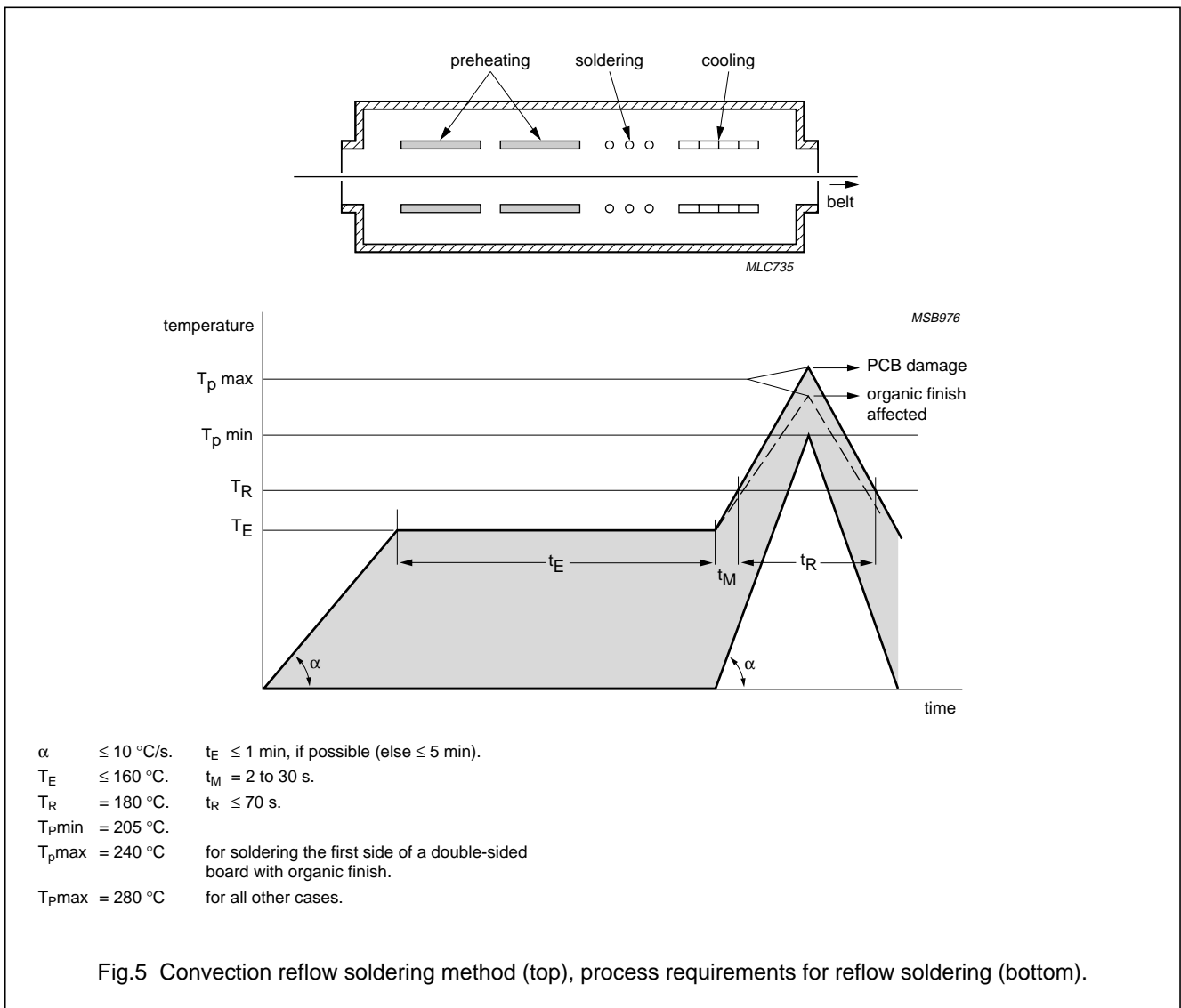

If soldering in a nitrogen atmosphere, a peak temperature of 280 °C is allowed for double-sided print boards or single-sided reflow soldering. Soldering in a nitrogen atmosphere results in smoother joint meniscus, smaller contact angles, and better wetting of the copper solder lands.

The profile can be achieved by correct combinations of conveyor speed and heater temperature. To check whether the profile is within specification, the coldest and hottest spots on the board have to be located.

To do this, you should dispense solder paste deposits regularly over the surface of a test board and on the component leads. Set the oven to a moderate temperature with maximum conveyor velocity and pass the test board through. If too many solder paste dots melt, lower the oven's temperature. Continue passing test boards through the oven, while lowering the speed of the belt in small steps.

The deposit that melts first indicates the warmest location, the one that melts last indicates the coldest location. Paste dots not reflowed after two runs must be replaced by fresh dots. Thermocouples have to be mounted at the coldest and warmest location and temperature profiles measured.

Double-wave soldering process

There are four basic process steps for double-wave soldering, these are:

1. Applying adhesive
2. Component placement
3. Curing adhesive
4. Wave soldering process.

APPLYING ADHESIVE

To hold SMDs on the board during wave soldering, it is necessary to bond the component to the PCB with one or more adhesive dots. This is done either by dispensing, stencilling or pin transfer. Dispensing is currently the most popular technique. It is flexible and allows a controlled amount of adhesive to be applied at each position. Stencil printing and pin transfer are less flexible and are mainly used for mass production. The component-specific requirements for an adhesive dot are:

- Shape (volume) of the adhesive dot
- Number of dots per component
- Position of the dots.

Volume of adhesive

There must be enough adhesive to keep components in their correct positions while being transported to the curing oven. This means that the deposited adhesive must be higher than the gap between the component and the board surface. Nevertheless, there should not be too much deposit as it may smear onto the solder lands, where it can affect their solderability. The gap between a component and printed board depends on the geometry of the board and component (see Fig.6).

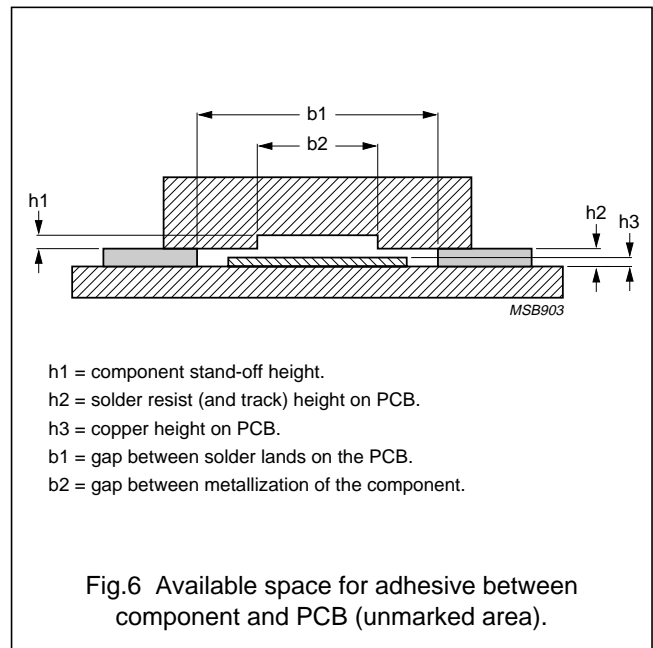

Table 2 gives guidelines for volumes of adhesive dots per package. The spreading in volumes should be within ±15%.

Table 2 Guidelines for volumes of adhesive dots

COMPONENT	NUMBER OF DOTS	VOLUME PER DOT (mm ³)
SOD106(A)	1	0.65
SOD80(C), SOD87	1 2	0.5 0.08
SOD110, SOD323	2	0.065
SOT323 (SC70-3)	2	0.045
SOT23, SOT143, SOT 346 (SC59)	2	0.06
SOT89	2	0.3
SOT223	2	0.70

Small-signal and Medium-power Diodes

Mounting and soldering

Number, position and volume of dots per component

Figure 7 shows the recommended positions and numbers of adhesive dots for a variety of packages. SOD106(A), SOT89 and SOT223 packages require much larger

adhesive dots compared with those for other components. SOD80(C) and SOD87 packages can have one large adhesive dot (recommended) or two smaller adhesive dots.

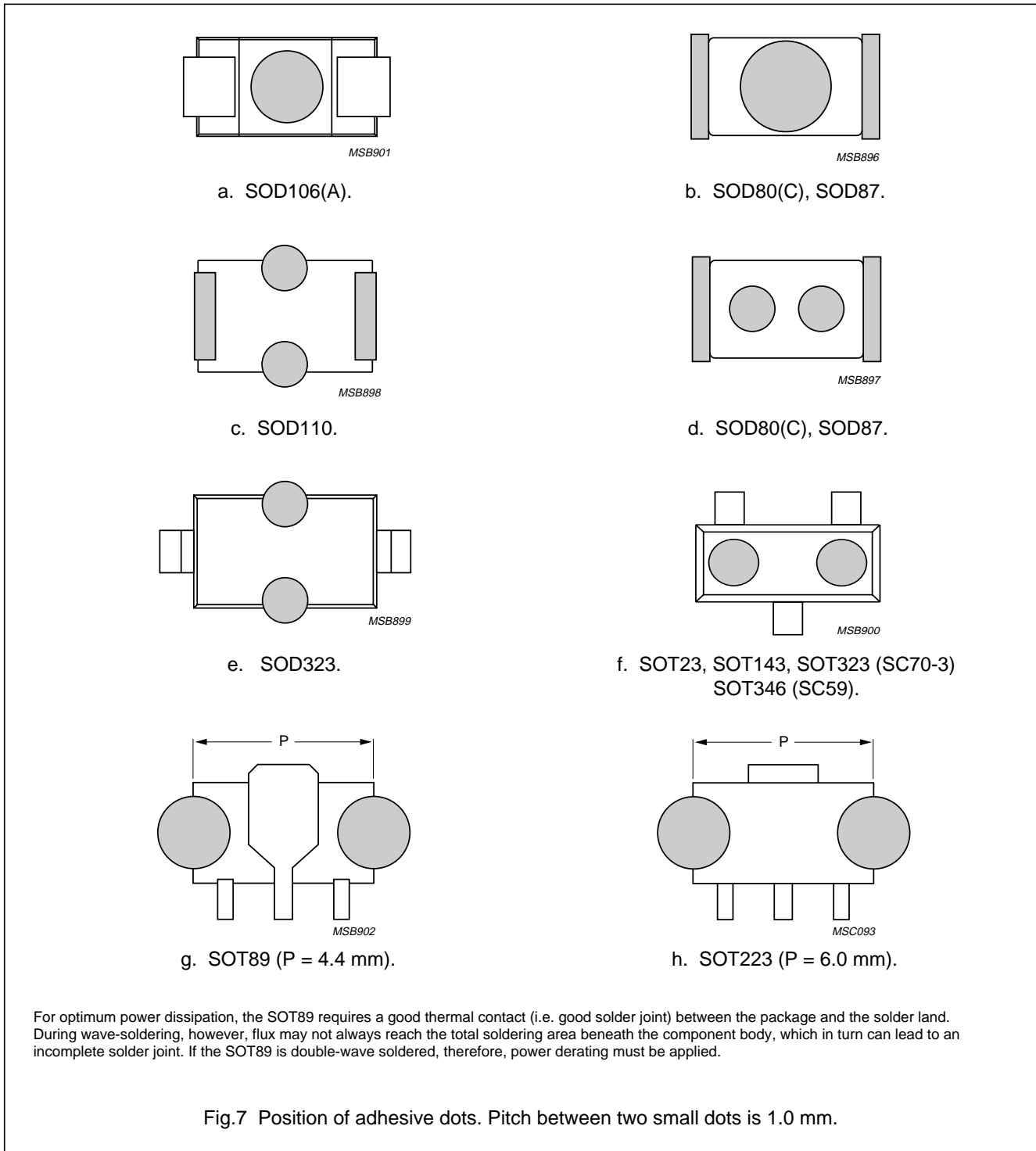

Nozzle outlet diameter

Depending on adhesive type and component size, the nozzle outlet diameter of the dispenser can vary between 0.6 and 0.7 mm for the larger dots, and between 0.3 and 0.5 mm for the smaller dots.

As the rheology of the adhesive is temperature dependent, the temperature in the nozzle must be carefully controlled before dispensing. The required temperature depends on the adhesive type, but is usually between 26 °C and 32 °C to maintain the adhesive's rheology within specification during dispensing. Thermally curing epoxy adhesives are normally used.

Adhesives

Beside the nozzle diameters, different adhesive types are also used for different component sizes. Small components can be secured during assembly and wave soldering with a thin (low green strength) adhesive, which can be dispensed at high speeds. For larger components (such as QFP and SO packages), a higher green strength adhesive is required.

COMPONENT PLACEMENT

Positioning components on the PCB is similar in practice to that of reflow soldering.

To prevent component shift and smearing of the adhesive, board support is important while placing components. This is particularly important when placing the SOD106(A) package.

CURING THE ADHESIVE

To provide sufficient bonding strength between component and board, the adhesive must be properly cured. Figure 8 gives general process requirements for curing most thermosetting epoxy adhesives with latent hardeners. The temperature profile of all adhesive dots on the PCB must be within this framework. It's important to note that this profile is for discrete semiconductor packages. The actual framework for the entire PCB could be smaller than the one shown, as other components on the board may have different process requirements.

To check whether the profile is within specification, the temperature of coldest and hottest spots must be measured. The coldest spot is usually under the largest package: the hottest spot is usually under the smallest package.

The adhesive can be cured either by infrared or hot-air convection.

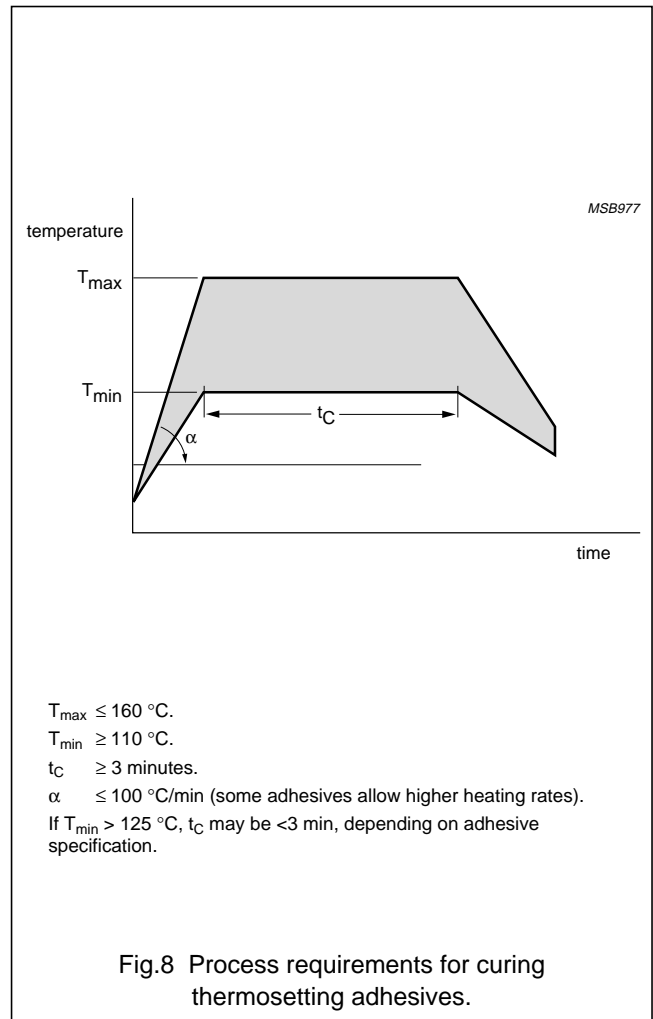

Bonding strength

The bonding strength of glued components on the board can be checked by measuring the torque force. For small components the requirements are given in Table 3. No values are specified for larger packages.

Table 3 Bonding strength requirements

COMPONENT	MINIMUM BONDING STRENGTH (cNcm)	TARGET BONDING STRENGTH (cNcm)
SOD323, SOD110, SOT323 (SC70-3)	110	250
SOD80(C), SOD87	200	350
SOT23, SOT346 (SC59), SOT143	150	250

Small-signal and Medium-power Diodes

Mounting and soldering

WAVE SOLDERING PROCESS

After applying adhesive, placing the component on the PCB and curing, the PCB can be wave soldered. The wave soldering process is basically built up from three sub-processes. These are:

1. Fluxing
2. Preheating
3. (Double) wave soldering.

Although listed here as sub-process they are in practice combined in one machine. All are served by one transport mechanism, which guides the PCBs at an incline through the soldering machine. It's important to note that the PCB must be loaded into the machine so that the SMDs on the board come into direct contact with the solder wave (see Fig.9).

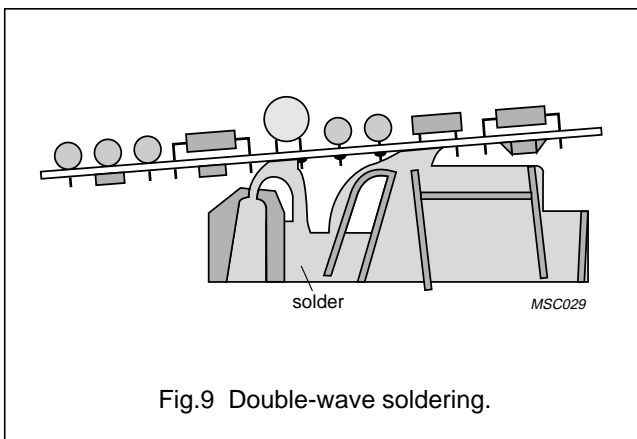

Fig.9 Double-wave soldering.

In principle, two different systems of PCB transports are available for wave soldering:

- **Carrier transport**
PCBs are mounted on a soldering carrier, which moves through the soldering machine, taking it from one sub-process to the next. The advantage of carrier mounting is that the board is fixed and warpage during soldering is reduced.
- **Carrierless transport**
PCBs are guided through the soldering machine by a chain with grips. This method is more convenient for mass production.

Fluxing

Fluxing is necessary to promote wetting both of the PCB and the mounted components. This ensures a good and even solder joint.

During the fluxing process, the solder side of the PCB (including the components) are covered with a thin layer of solder flux, which can be applied to the PCB either by spraying or as a foam. Although several types of solder flux are available for this purpose, they can be categorized into three main groups:

- Non-activated flux (e.g. rosin-based fluxes)
- Mildly activated flux (e.g. rosin-based or synthetic fluxes)
- Highly activated flux (e.g. water-soluble fluxes).

The choice for a particular flux type depends mainly on the products to be soldered.

Although there is always some flux residue left on the PCB after soldering, it's not always necessary to wash the boards to remove it. Whether to clean the board can depend on:

- The type of flux used (highly activated fluxes are corrosive and so should always be removed).
- The required appearance of the board after soldering.
- Customer requirements.

Preheating

After the flux is applied, the PCB needs to be preheated. This serves several purposes: it evaporates the flux solvents, it accelerates the activity of the flux and it heats the PCB and components to reduce thermal shock.

The required pre-heat temperature depends on the type of flux used. For example, the more common low-residue fluxes require a pre-heat temperature of 120 °C (measured on the wave solder side of the PCB).

(Double) wave soldering

The PCB first passes over a highly intensive (jet) solder wave with a carefully controlled constant height. This ensures good contact with the PCB, the edges of SMDs and the leads of components near to high non-wetted bodies. The greater the board's immersion depth into this first wave, the fewer joints will be missed.

If the PCB is carrier mounted, the first wave's height, and thus the board's immersion depth, can be greater. Carrierless soldering is more convenient for mass production, but the height of the wave must be lower to avoid solder overflowing to the top side of the board. The height of the jet wave is given in Table 4 along with an indication of soldering process window. This information is based on a 1.6 mm thick PCB.

Small-signal and Medium-power Diodes

Mounting and soldering

Table 4 Process ranges for carrierless and carrier double wave soldering

	CARRIERLESS	CARRIER
Preheat temperature of board at wave solder side (°C)	120 ±10	
Heating rate preheating (°C/s)	$\Delta T/\Delta t \leq 3$	
First (jet) wave: wave height with respect to bottom side of board (mm)	1.6 +0.5/-0	3.0 +0.5/-0
Second (laminar) wave (double sided overflow): height with respect to underside of the board (mm) relative stream velocity with respect to the board	0.8 +0.5/-0 0	
Solder temperature (°C)	250 ±3	
Contact times (s): first (jet) wave second (laminar) wave	0.5 +0.5/-0 2.0 ±0.2 (plain holes); 2.5 ±0.2 (plated holes)	
PCB transport angle (°)	7 ±0.5	
Solder alloys	Sn60Pb40; Sn60Pb38Bi2	

The second, smoother laminar solder wave completes formation of the solder fillet, giving an optimal soldered connection between component and PCB. It also reduces the possibility of solder bridging by taking up excessive solder.

To reduce lead/tin oxides and possibly other solder imperfection forming during soldering, the complete wave configuration can be encapsulated by an inert atmosphere such as nitrogen.

Hand soldering microminiature components

It is possible to solder microminiature components with a light-weight hand-held soldering iron, but this method has obvious drawbacks and should be restricted to laboratory use and/or incidental repairs on production circuits:

- Hand-soldering is time-consuming and therefore expensive
- The component cannot be positioned accurately and the connecting tags may come into contact with the substrate and damage it
- There is a risk of breaking the substrate and internal connections in the component could be damaged
- The component package could be damaged by the iron.

Assessment of soldered joint quality

The quality of a soldered joint is assessed by inspecting the shape and appearance of the joint. This inspection is normally done with either a low-powered magnifier or microscope, however where ultra-high reliability is required, video, X-ray or laser inspection equipment may be considered.

Both sides of the PCB should be carefully examined: there should be no misaligned, missing or damaged components, soldered joints should be clean and have a similar appearance, there should be no solder bridging or residue, and the PCB should be assessed for general cleanliness.

Unlike leaded component joints where the lead also provides added mechanical strength, the SMD relies on the quality of the soldering for both electrical and mechanical integrity. It is therefore necessary that the inspector is trained to make a visual assessment with regard to long-term reliability.

Criteria used to assess the quality of an SMD solder joint include:

- Correct position of the component on the solder lands
- Good wetting of the surfaces
- Correct amount of solder
- A sound, smooth joint surface.

Small-signal and Medium-power Diodes

Mounting and soldering

POSITIONING

If a lead projects over the solder land too far an unreliable joint is obtained. Figures 10 to 12 show the maximum shift allowed for various components. The dimensions of these solder lands guarantee that, in the statistically extreme situation, a reliable soldered joint can be made.

GOOD WETTING

This produces an even flow of solder over the surface land and component lead, and thinning towards the edges of the joint. The metallic interaction that takes place during soldering should give a smooth, unbroken, adherent layer of solder on the joint.

CORRECT AMOUNT OF SOLDER

A good soldered joint should have neither too much nor too little solder: there should be enough solder to ensure electrical and mechanical integrity, but not so much that it causes solder bridging.

SOUND, SMOOTH JOINT SURFACE

The surface of the solder should be smooth and continuous. Small irregularities on the solder surface are acceptable, but cracks are unacceptable.

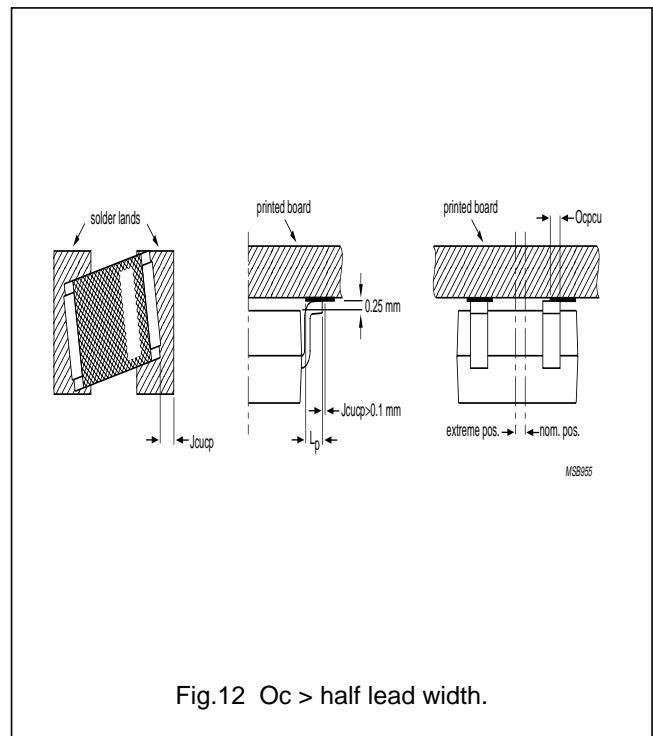
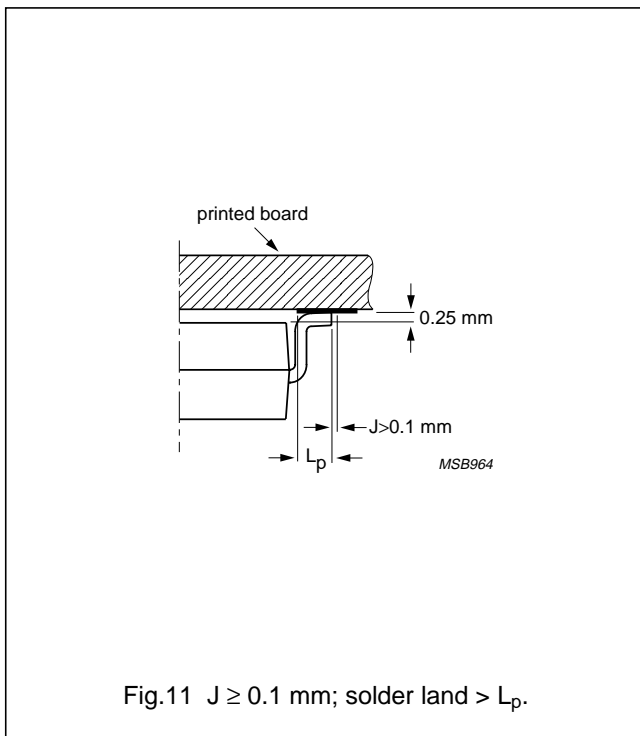
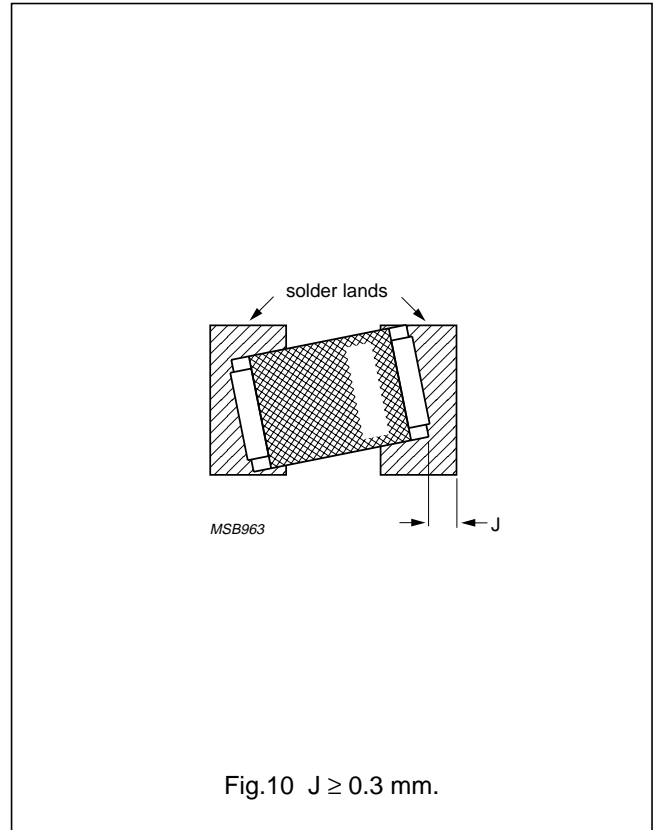

Small-signal and Medium-power Diodes

Mounting and soldering

Footprint definitions

A typical SMD footprint, is composed of:

- Solder lands (conductive pattern)
- Solder resist pattern
- Occupied area of the component
- Solder paste pattern (for reflow soldering only)
- Area underneath the SMD available for tracks
- Component orientation during wave soldering.

SOLDER LANDS (CONDUCTIVE PATTERN)

The dimensions of the solder lands given in these guidelines are the actual dimensions of the conductive pattern on the printed board (see Fig.13). These dimensions are more crucial for fine-pitch components.

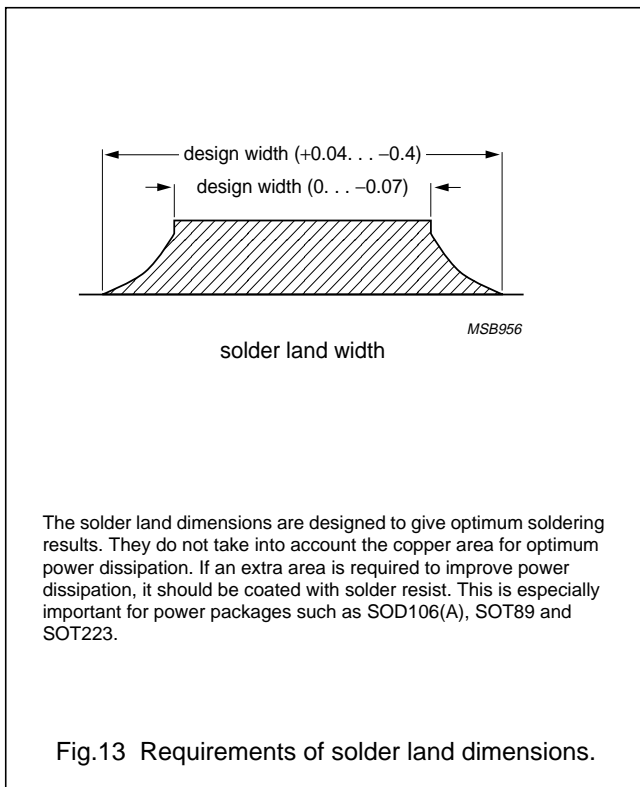

SOLDER RESIST PATTERN

The solder resist on the circuit board prevents short circuits during soldering, increases the insulation resistance between adjacent circuit details and stops solder flowing away from solder lands during reflow soldering.

In contrast to the tracks, which must be entirely covered, solder lands must be free of solder resist. Because of this, the cut-outs in the solder resist pattern should be at least 0.15 mm or 0.3 mm larger than the relevant solder lands (for a photo-defined and screen printed solder resist pattern respectively). The solder resist cut-outs given with the footprints in these guidelines are sketched and their dimensions can be calculated by using the above rule. Consult your printed board supplier for agreement with these solder resist cut-outs.

OCCUPIED AREA OF THE COMPONENT

A minimum spacing between components is necessary to avoid component placement problems, short circuits during wave or reflow soldering and dry solder joints during wave soldering caused by non-wettable component bodies. These problems can be avoided by placing the components so the occupied areas do not overlap (see Fig.14).

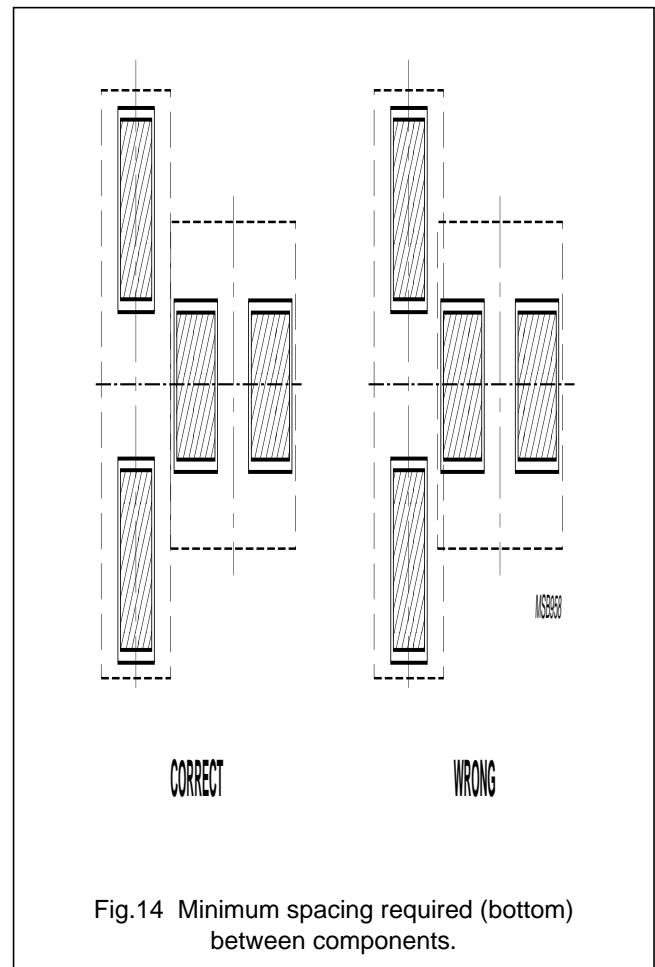

SOLDER PASTE PATTERN

It is important to use a solder paste printer which is optical aligned with the PCBs copper pattern for the reflow footprints presented here. This is because, for these footprints, the solder paste deposit must be within a 0.1 mm tolerance with respect to the copper pattern.

To ensure the right amount of solder for each solder joint, the stencil apertures must be equal to the solder paste areas given by the footprints.

AREA AVAILABLE FOR TRACKS (CONDUCTIVE PATTERN)

Tracks underneath leadless SMDs must be covered with solder resist. However, as solder resist can sometimes be thin or have pin holes at the edges of tracks (especially when applied by screen printing), an additional clearance for tracks with respect to the actual metallization position of the mounted component should be taken into account (see Fig.15).

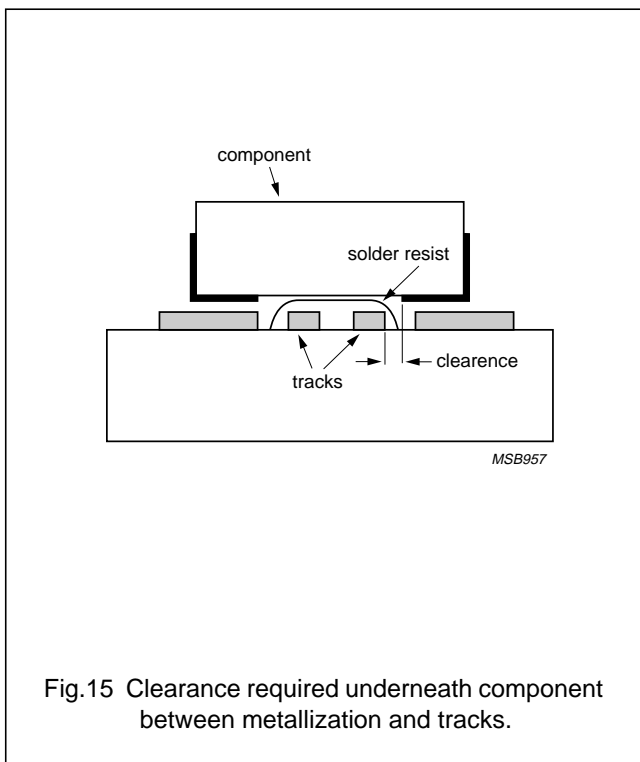

Fig.15 Clearance required underneath component between metallization and tracks.

For components that need the additional clearance, the footprints on the following pages give the maximum space for tracks not connected to the solder lands (clearance ≥ 0.1 mm), for low-voltage applications. The number of tracks in this space is determined by the specified line resolution of the printed board.

COMPONENT ORIENTATION DURING WAVE SOLDERING

Where applicable, footprints for wave soldering are given with the transport direction of the PCB. This is given as either a 'preferred transport direction during soldering' or 'transport direction during soldering'.

Components with small terminals and non-wettable bodies, have a smaller risk of dry joints, especially when using carrierless soldering as the components are placed according to the 'preferred orientation'.

Components have no orientation preference for reflow soldering.

Recommended footprints

The recommended footprints for our discrete semiconductor packages are given on the following pages. For their dimensional outline drawings, see the 'Package outlines' section at the end of this book.

In addition to its standard footprints, SOD110 has a reflow footprint for high thermal cycling load applications (see Fig.16). This footprint has larger solder lands to give a fatter solder fillet and, therefore, longer solder fatigue life. A SOD110 mounted on this footprint has a lower self-aligning ability, and has a higher risk of displacement when soldered in a nitrogen atmosphere.

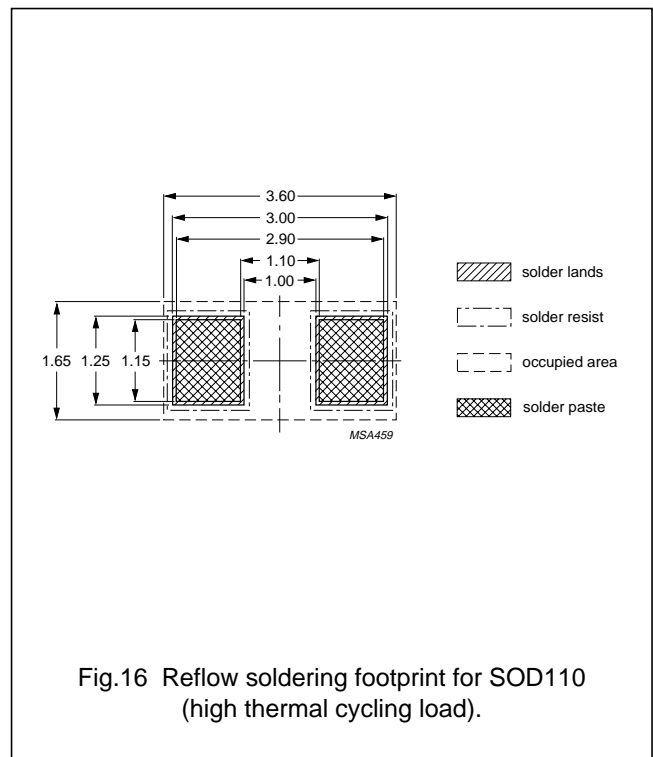

Fig.16 Reflow soldering footprint for SOD110 (high thermal cycling load).

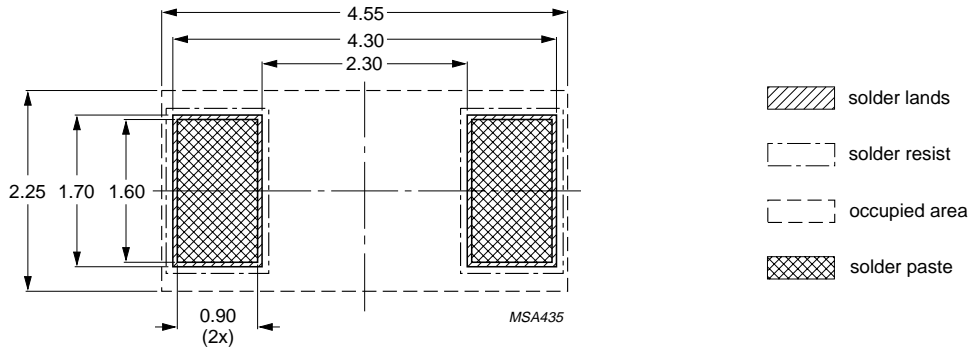

Fig.17 Reflow soldering footprint for SOD80(C).

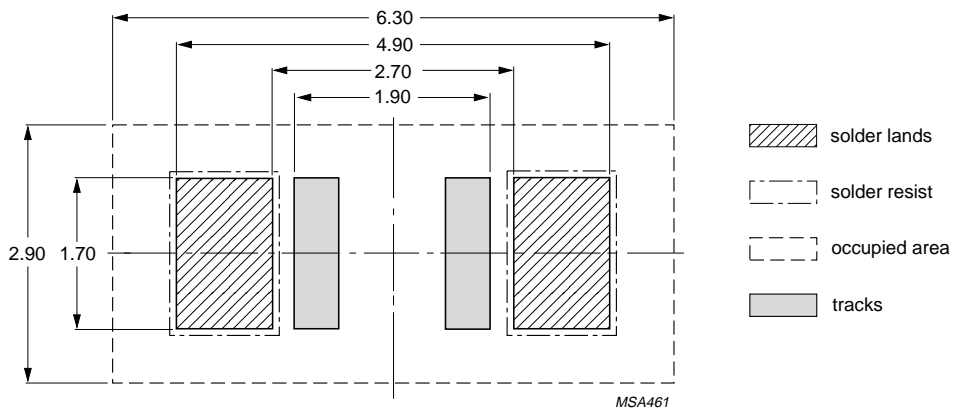

Fig.18 Wave soldering footprint for SOD80(C).

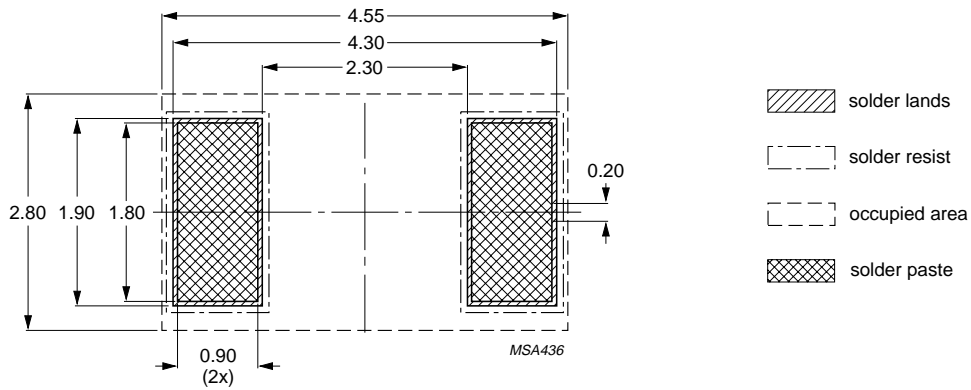

Fig.19 Reflow soldering footprint for SOD87.

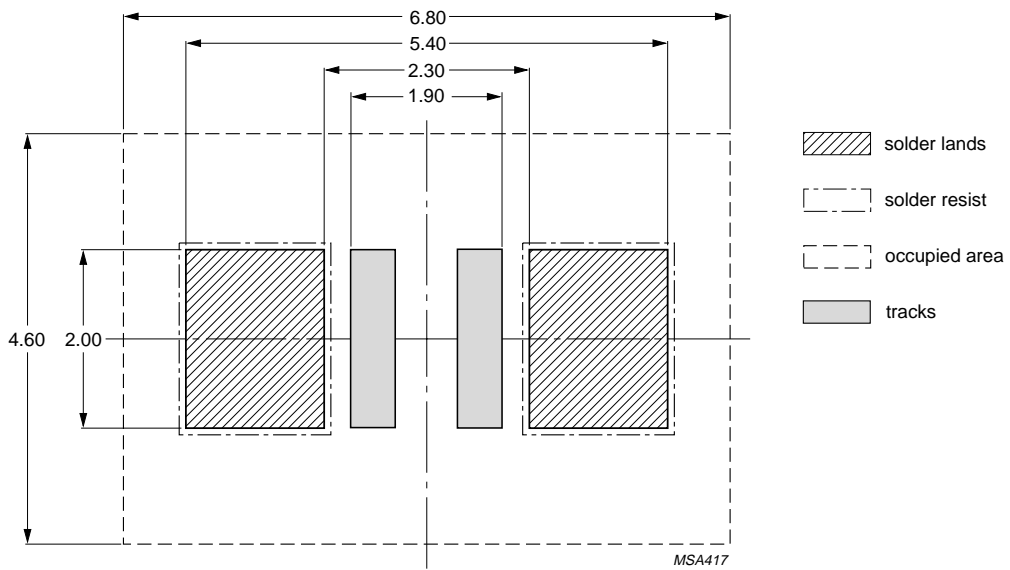
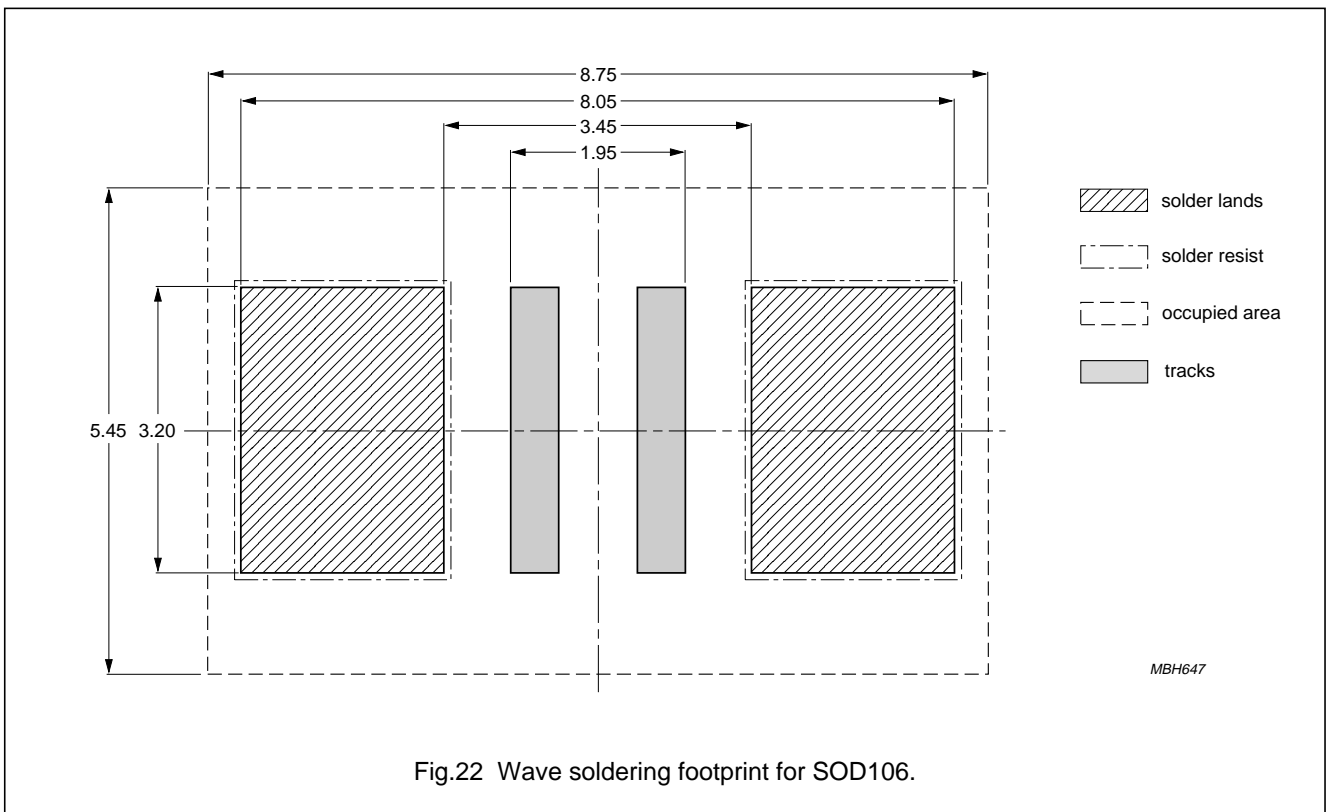
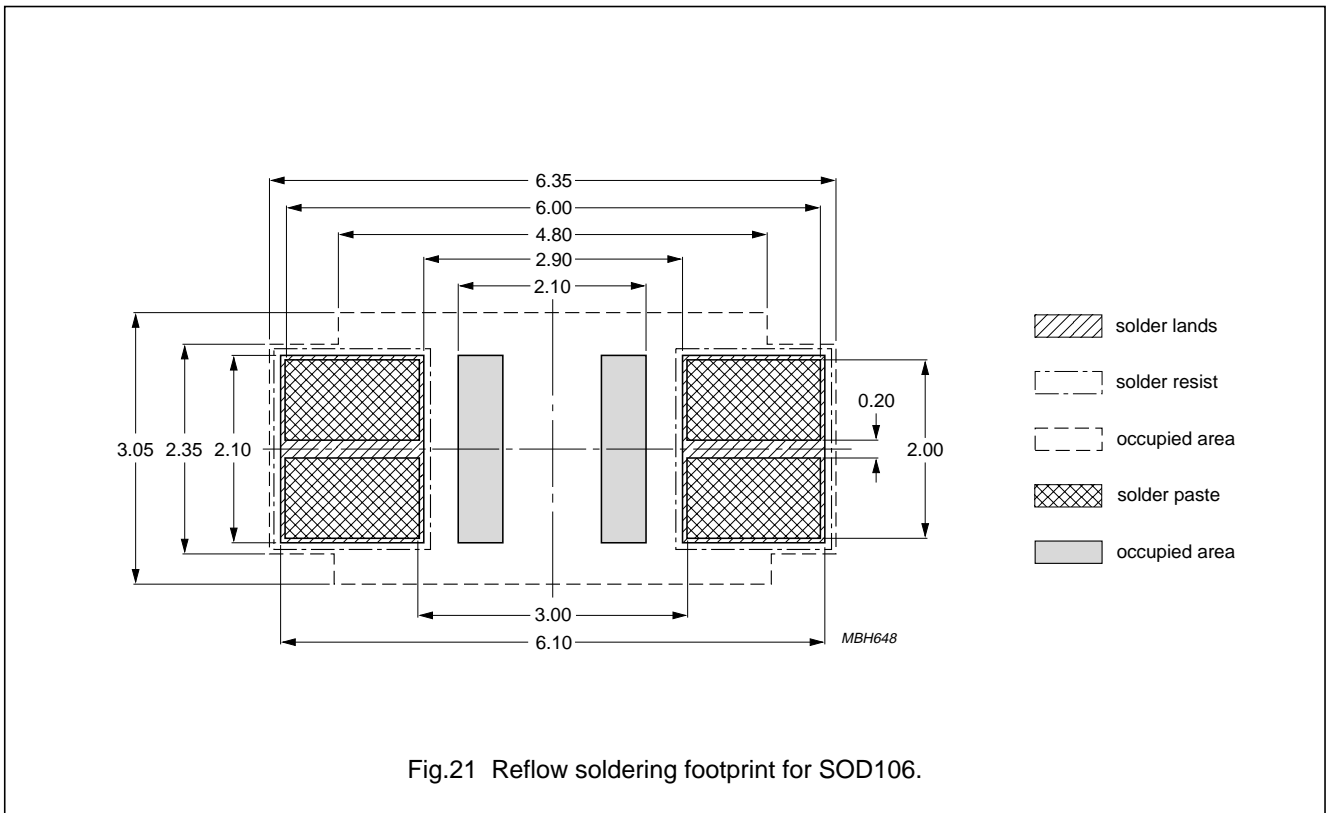

Fig.20 Wave soldering footprint for SOD87.



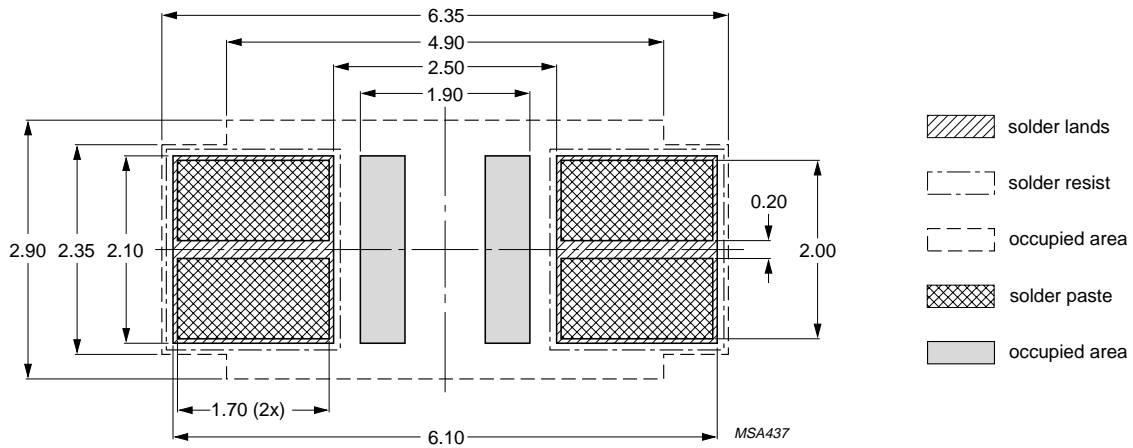

Fig.23 Reflow soldering footprint for SOD106(A).

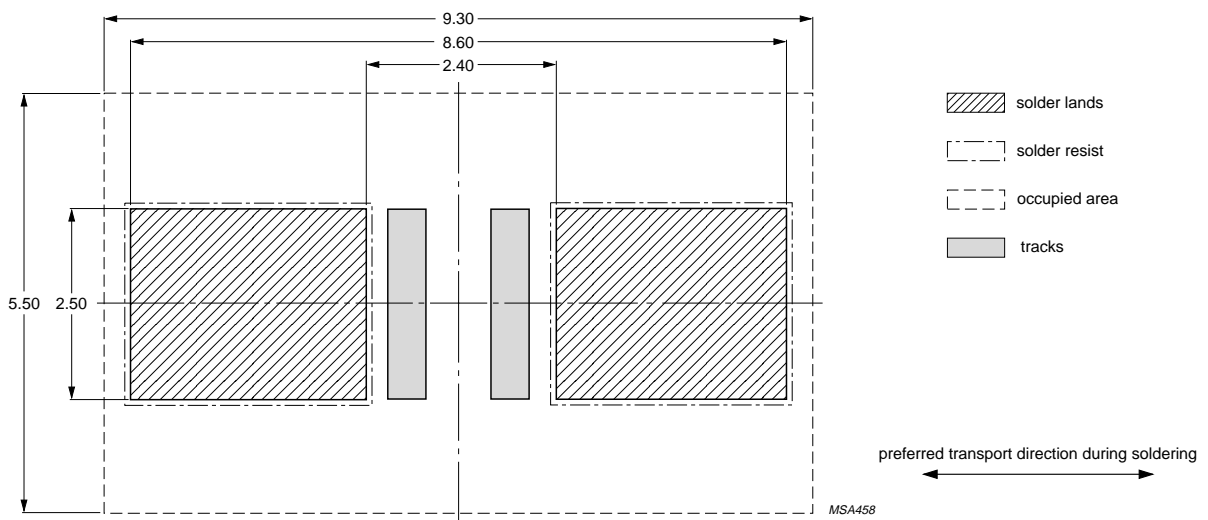

Fig.24 Wave soldering footprint for SOD106(A).

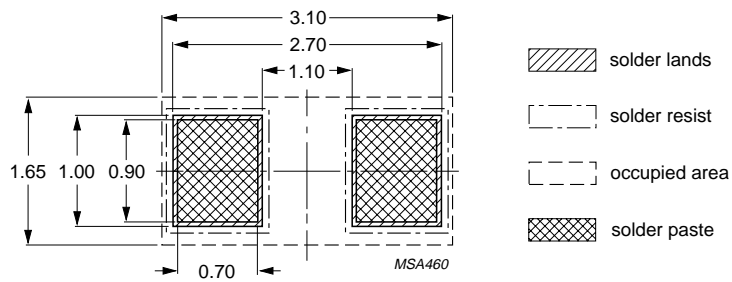

Fig.25 Reflow soldering footprint for SOD110.

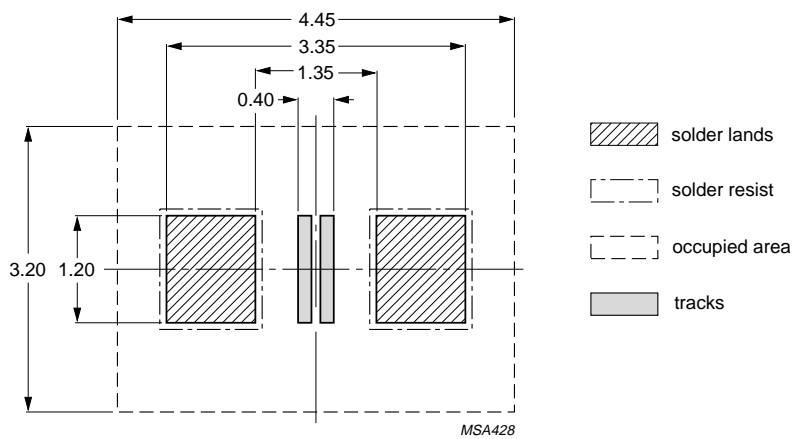

Fig.26 Wave soldering footprint for SOD 110.

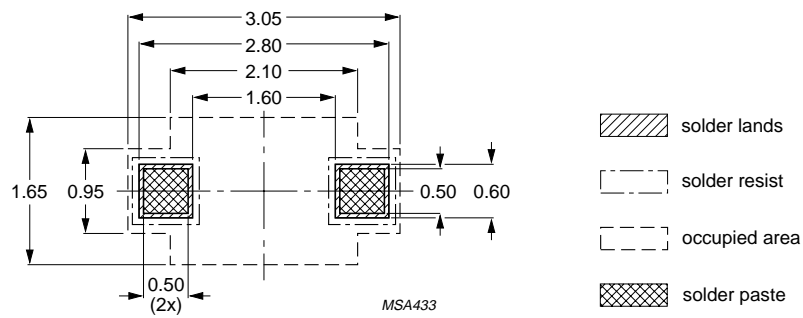

Fig.27 Reflow soldering footprint for SOD323.

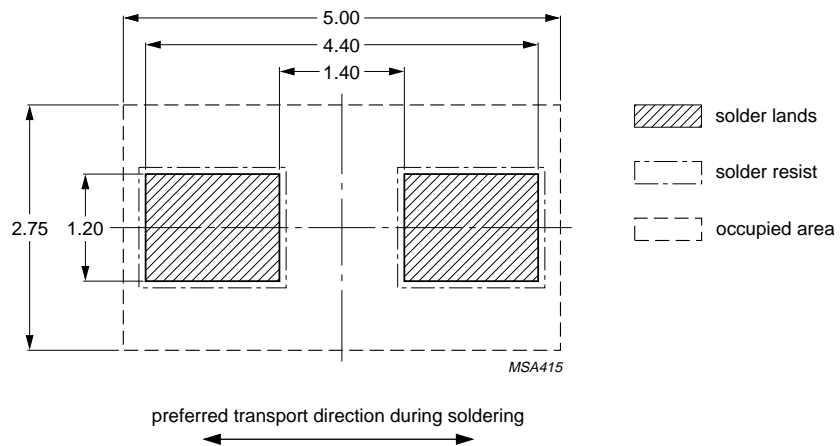

Fig.28 Wave soldering footprint for SOD323.

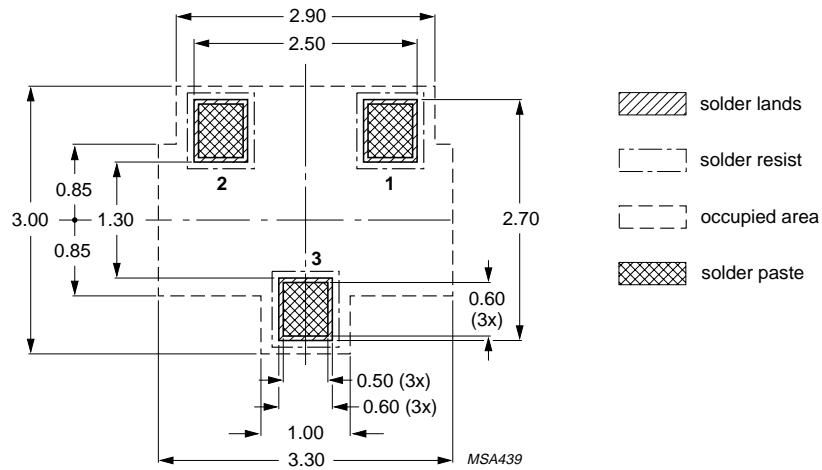

Fig.29 Reflow soldering footprint for SOT23.

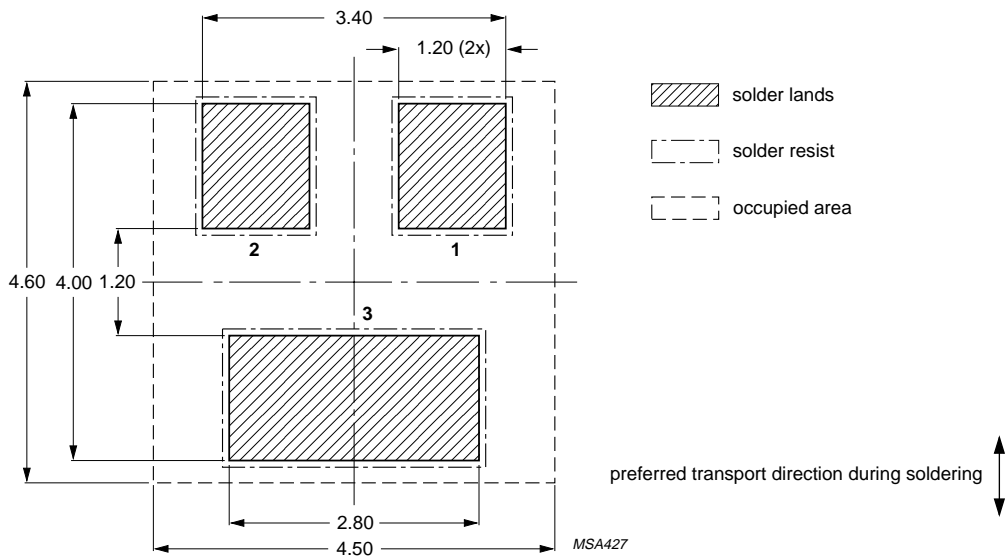

Fig.30 Wave soldering footprint for SOT23.

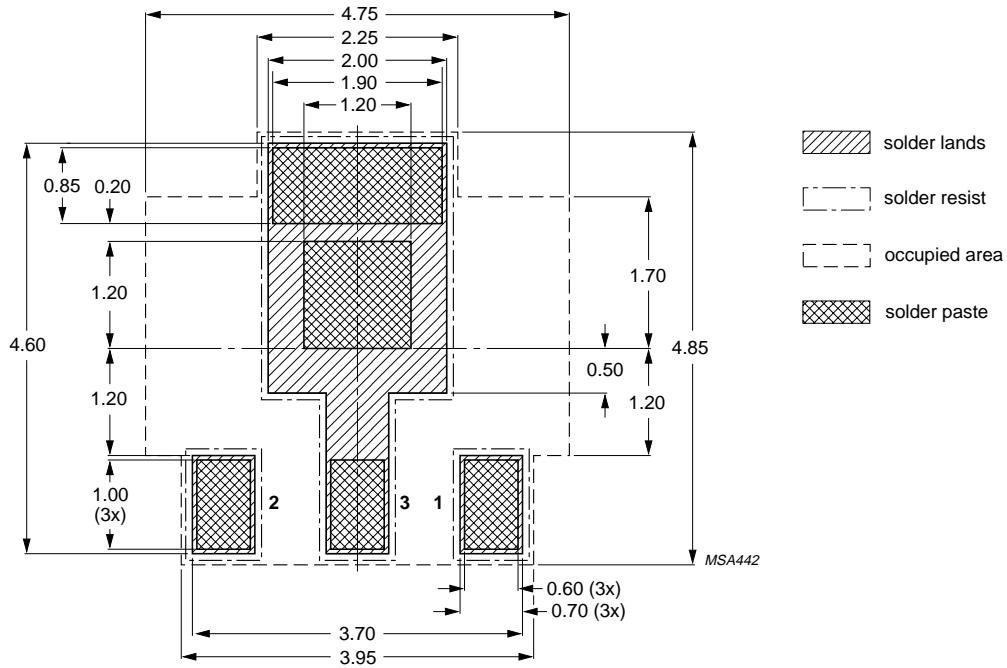
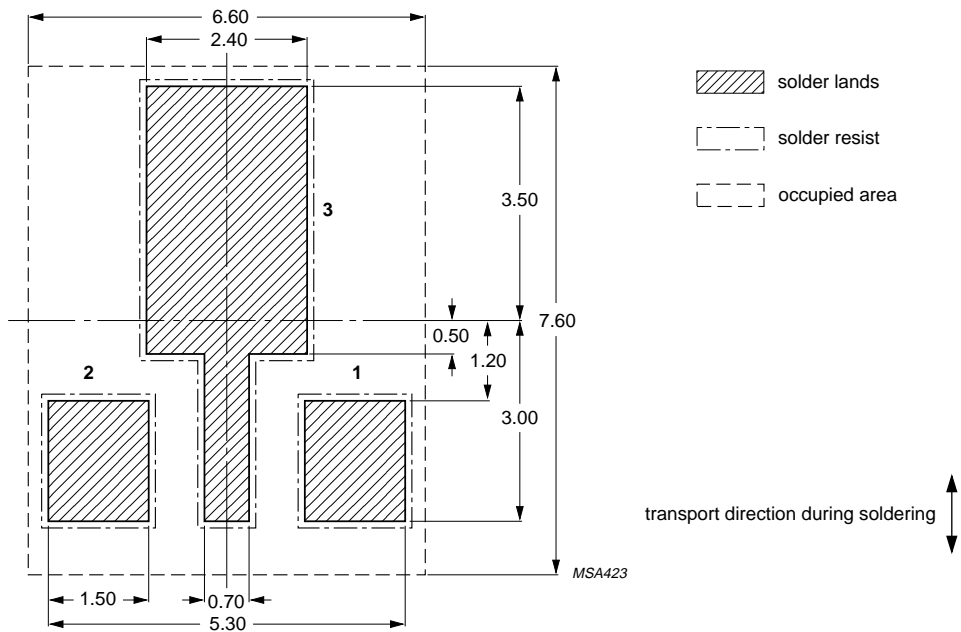

Fig.31 Reflow soldering footprint for SOT89.



Not recommended for wave soldering (see Fig.7).

Fig.32 Wave soldering footprint for SOT89.

Small-signal and Medium-power Diodes

Mounting and soldering

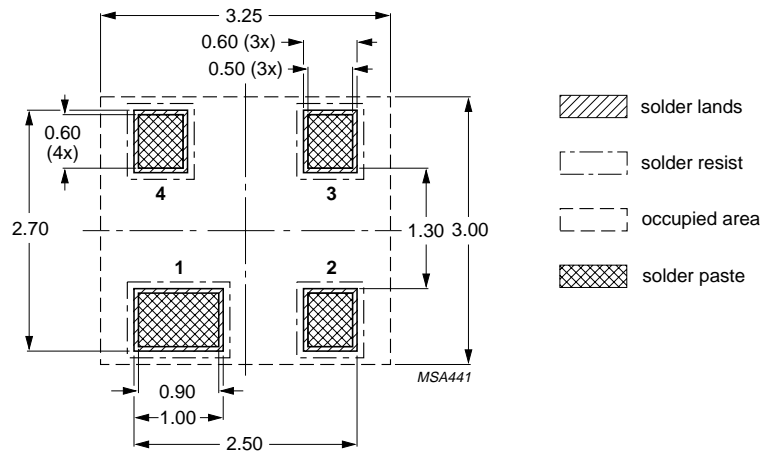

Fig.33 Reflow soldering footprint for SOT143 (footprint for SOT143R is mirror image).

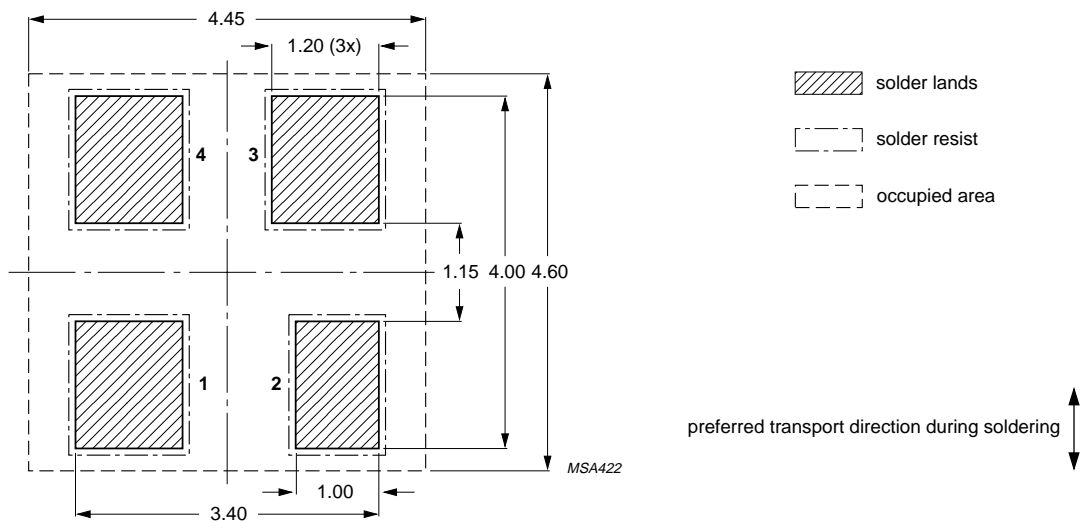
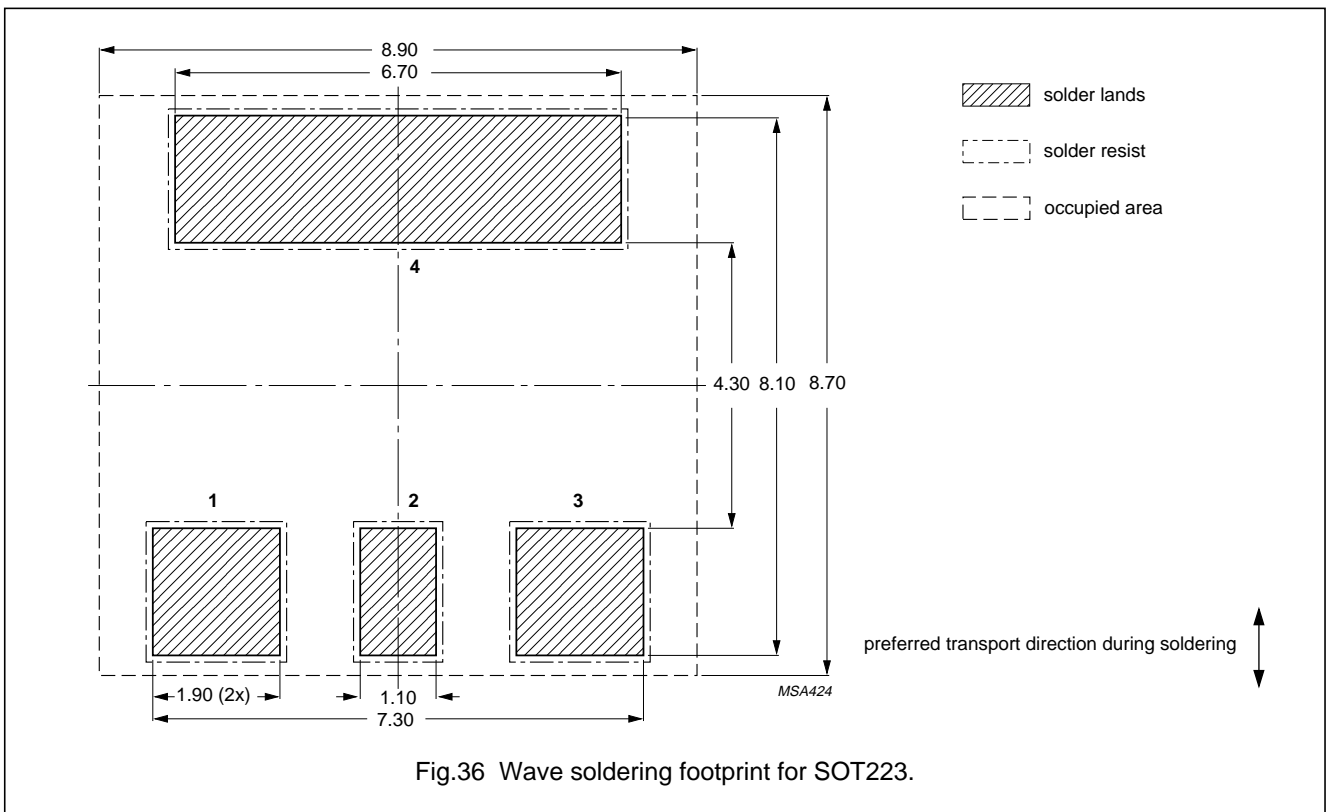
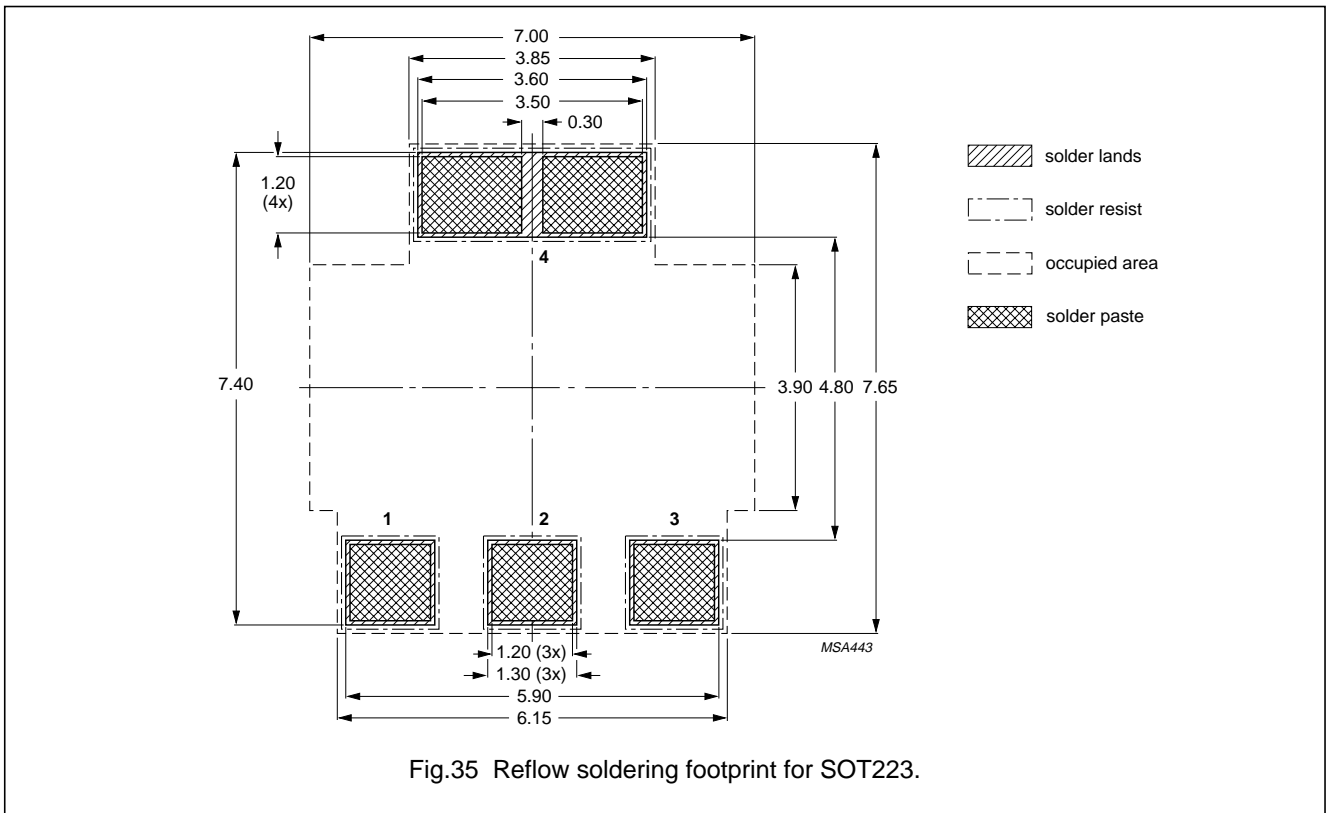

Fig.34 Wave soldering footprint for SOT143 (footprint for SOT143R is mirror image).



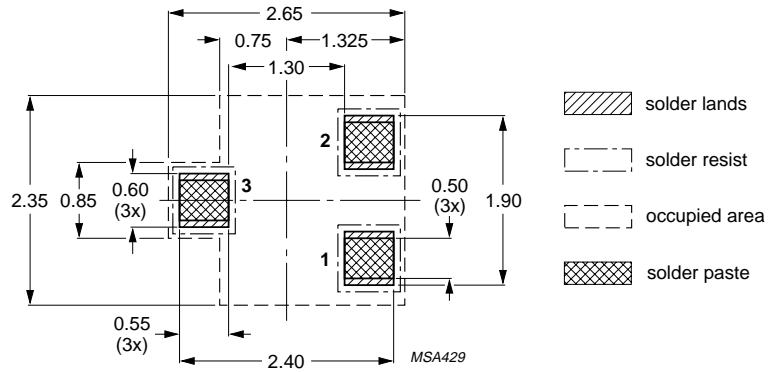

Fig.37 Reflow soldering footprint for SOT323 and SC70-3.

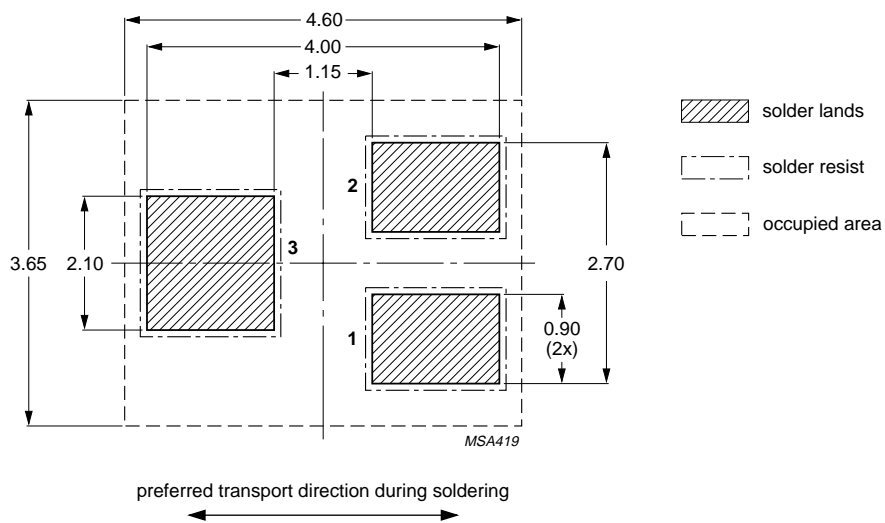
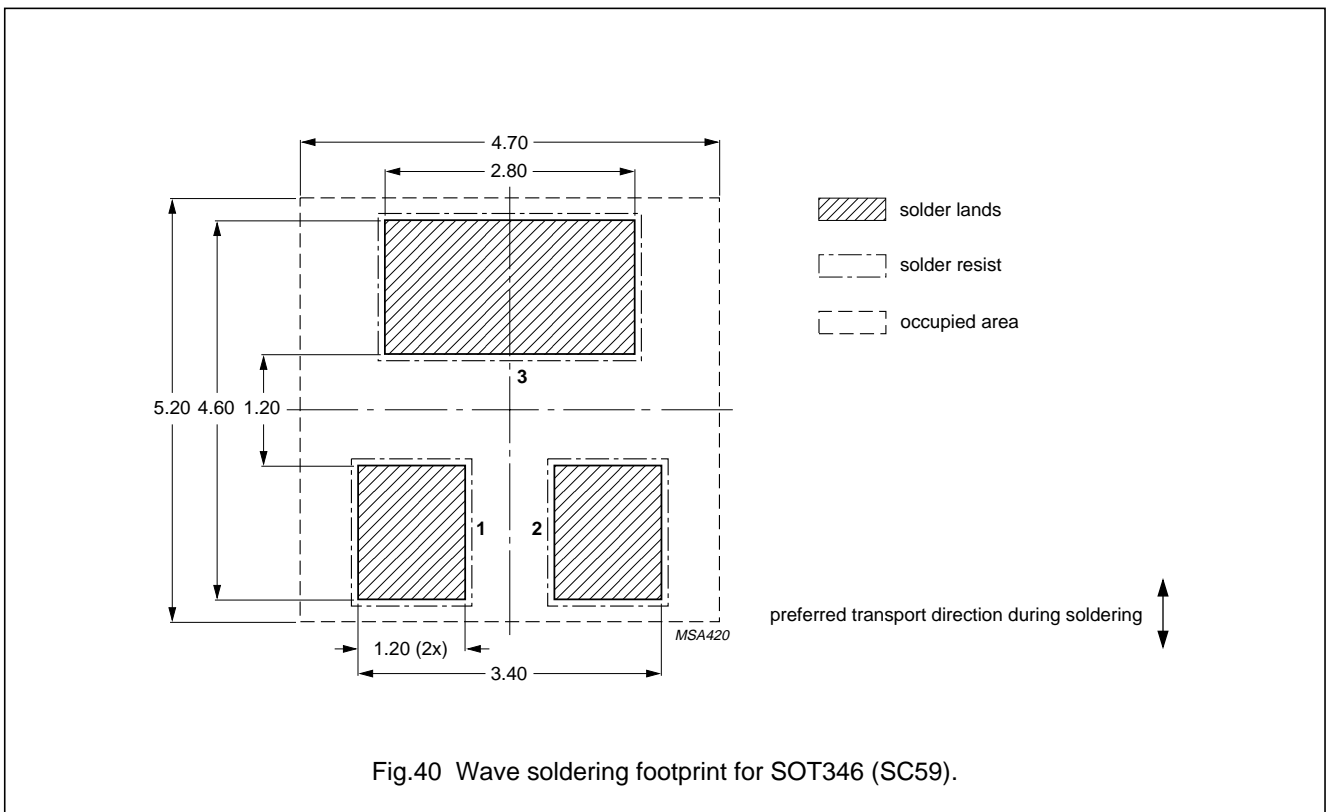
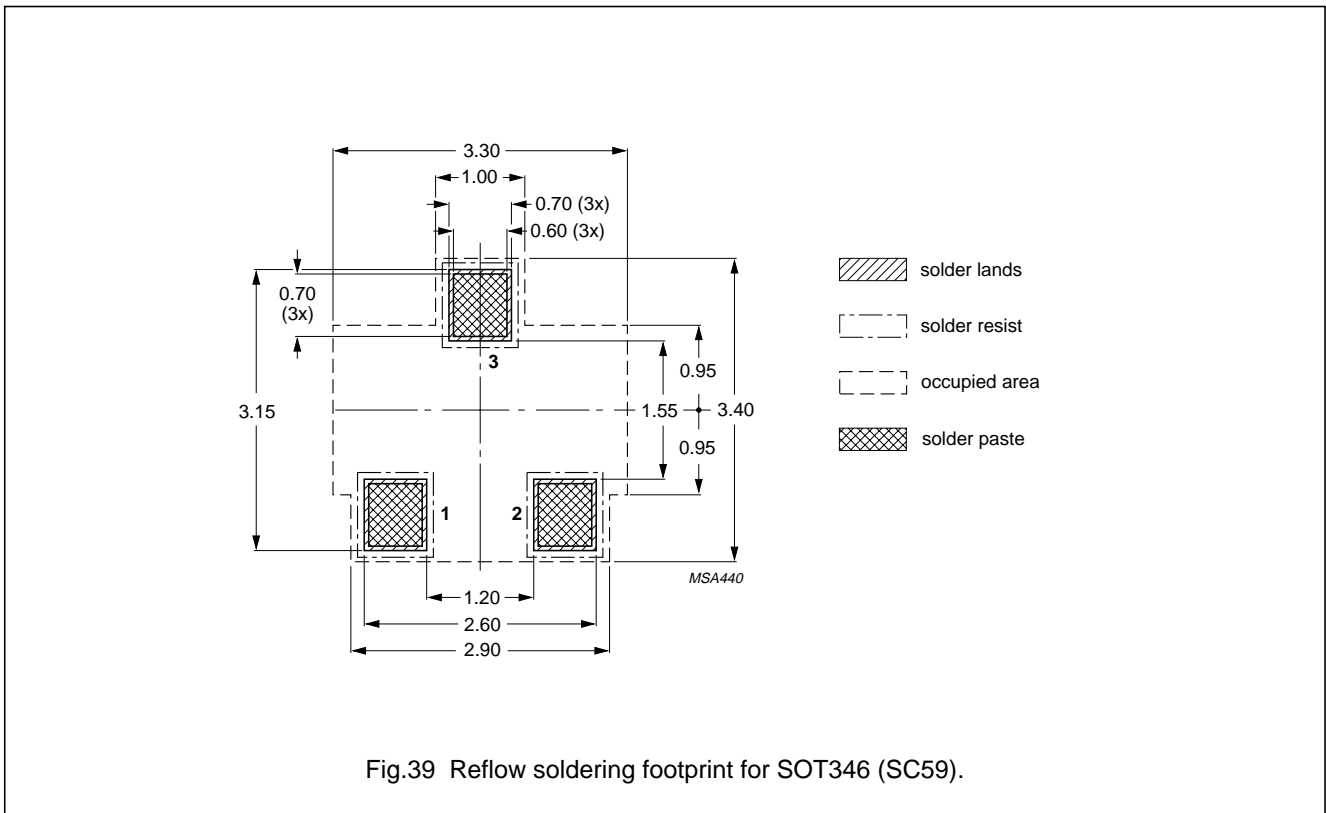

Fig.38 Wave soldering footprint for SOT323 and SC70-3.

Small-signal and Medium-power Diodes

Mounting and soldering



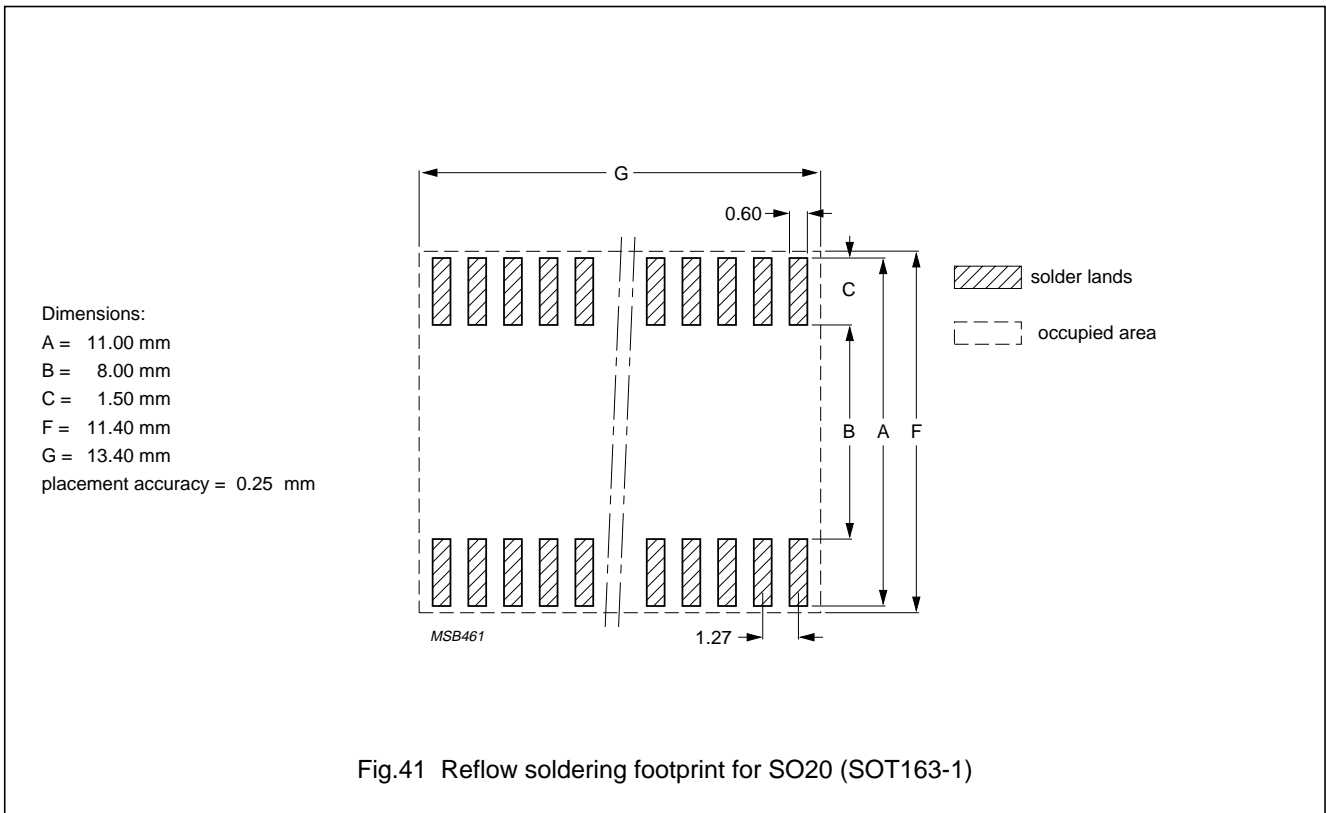

Fig.41 Reflow soldering footprint for SO20 (SOT163-1)

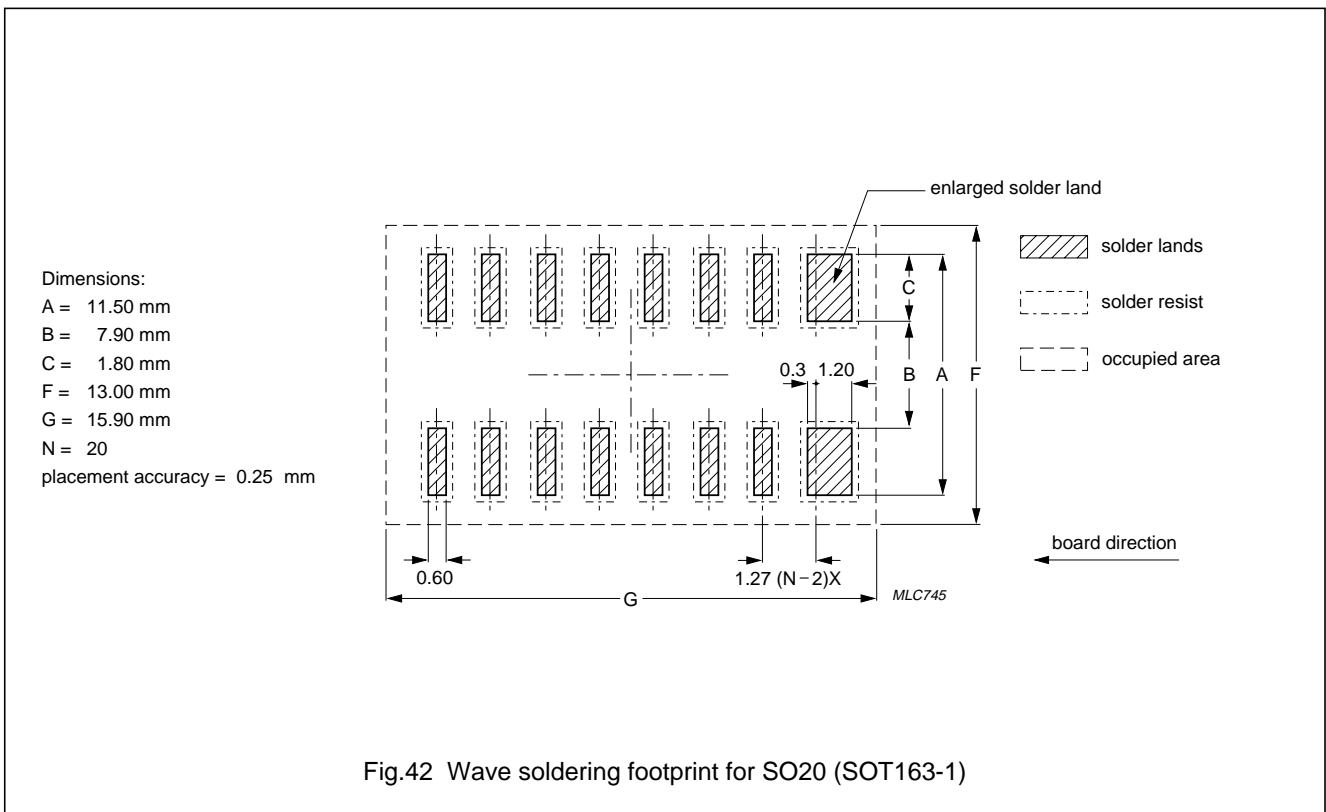

Fig.42 Wave soldering footprint for SO20 (SOT163-1)

Small-signal and Medium-power Diodes

Mounting and soldering

SUNSTAR 商斯达实业集团是集研发、生产、工程、销售、代理经销、技术咨询、信息服务等为一体的高科技企业，是专业高科技电子产品生产厂家，是具有 10 多年历史的专业电子元器件供应商，是中国最早和最大的仓储式连锁规模经营大型综合电子零部件代理分销商之一，是一家专业代理和分销世界各大品牌 IC 芯片和电子元器件的连锁经营综合性国际公司，专业经营进口、国产名厂名牌电子元件，型号、种类齐全。在香港、北京、深圳、上海、西安、成都等全国主要电子市场设有直属分公司和产品展示展销窗口门市部专卖店及代理分销商，已在全国范围内建成强大统一的供货和代理分销网络。我们专业代理经销、开发生产电子元器件、集成电路、传感器、微波光电元器件、工控机/DOC/DOM 电子盘、专用电路、单片机开发、MCU/DSP/ARM/FPGA 软件硬件、二极管、三极管、模块等，是您可靠的一站式现货配套供应商、方案提供商、部件功能模块开发配套商。商斯达实业公司拥有庞大的资料库，有数位毕业于著名高校——有中国电子工业摇篮之称的西安电子科技大学（西军电）并长期从事国防尖端科技研究的高级工程师为您精挑细选、量身订做各种高科技电子元器件，并解决各种技术问题。

微波光电部专业代理经销高频、微波、光纤、光电元器件、组件、部件、模块、整机；电磁兼容元器件、材料、设备；微波 CAD、EDA 软件、开发测试仿真工具；微波、光纤仪器仪表。欢迎国外高科技微波、光纤厂商将优秀产品介绍到中国、共同开拓市场。长期大量现货专业批发高频、微波、卫星、光纤、电视、CATV 器件：晶振、VCO、连接器、PIN 开关、变容二极管、开关二极管、低噪晶体管、功率电阻及电容、放大器、功率管、MMIC、混频器、耦合器、功分器、振荡器、合成器、衰减器、滤波器、隔离器、环行器、移相器、调制解调器；光电子元件和组件：红外发射管、红外接收管、光电开关、光敏管、发光二极管和发光二极管组件、半导体激光二极管和激光器组件、光电探测器和光接收组件、光发射接收模块、光纤激光器和光放大器、光调制器、光开关、DWDM 用光发射和接收器件、用户接入系统光收发器件与模块、光纤连接器、光纤跳线/尾纤、光衰减器、光纤适配器、光隔离器、光耦合器、光环行器、光复用器/转换器；无线收发芯片和模组、蓝牙芯片和模组。

更多产品请看本公司产品专用销售网站：

商斯达中国传感器科技信息网：<http://www.sensor-ic.com/>

商斯达工控安防网：<http://www.pc-ps.net/>

商斯达电子元器件网：<http://www.sunstare.com/>

商斯达微波光电产品网：[HTTP://www.rfoe.net/](http://www.rfoe.net/)

商斯达消费电子产品网：<http://www.icasic.com/>

商斯达实业科技产品网：<http://www.sunstars.cn/> 微波元器件销售热线：

地址：深圳市福田区福华路福庆街鸿图大厦 1602 室

电话：0755-82884100 83397033 83396822 83398585

传真：0755-83376182 (0) 13823648918 MSN: SUNS8888@hotmail.com

邮编：518033 E-mail:szss20@163.com QQ: 195847376

深圳赛格展销部：深圳华强北路赛格电子市场 2583 号 电话：0755-83665529 25059422

技术支持：0755-83394033 13501568376

欢迎索取免费详细资料、设计指南和光盘；产品凡多，未能尽录，欢迎来电查询。

北京分公司：北京海淀区知春路 132 号中发电子大厦 3097 号

TEL: 010-81159046 82615020 13501189838 FAX: 010-62543996

上海分公司：上海市北京东路 668 号上海赛格电子市场 D125 号

TEL: 021-28311762 56703037 13701955389 FAX: 021-56703037

西安分公司：西安高新开发区 20 所(中国电子科技集团导航技术研究所)

西安劳动南路 88 号电子商城二楼 D23 号

TEL: 029-81022619 13072977981 FAX:029-88789382