

Surface mounted triacs and thyristors

Introduction

There is an ever growing need in the electronics industry for miniaturisation and cost reduction of the end product. In order to satisfy these requirements, designers are specifying Surface Mount Technology with increasing regularity. At first their attentions were aimed at the low power and small signal components. Now their attentions are turning towards the power devices in order to give them total surface mount solutions.

The increased miniaturisation is possible because surface mounted power semiconductors occupy less board area than through-hole-mounting devices on heatsinks. Cost reduction is possible due to the faster and simpler assembly that result when ALL components are surface mounted.

The availability of a wide range of package sizes permits continuous power dissipations ranging from 0.5 Watts to 2 Watts on standard Printed Circuit Boards. Higher power dissipations are achievable if special heatsinking provisions are made on the PCB. Some examples of these include:

- A grid of solder vias to a pad on the reverse side of the PCB.
- A PCB-mounted heatsink on one or both sides.
- An aluminium-cored PCB.
- Fan-assisted cooling.

Surface mount solutions from Philips

Philips Semiconductors has developed a full range of surface mount power packages for its entire range of triacs and thyristors. The assembly materials and technology used are not simply adapted from the pre-existing through-hole-mounting package technology; they are unique to SMT.

Every new SMT device is subjected to rigorous testing which originates from stringent automotive requirements. This consists of full reliability testing after three surface mounting operations on printed circuit boards. No failures will be generated. This gives the best assurance of reliable end products.

This Technical Publication will present the surface mount packages and show what thermal performances can be achieved on standard PCBs without special heatsinking arrangements.

SOT223

SOT223 (Fig. 1) is the smallest SMT power package presented in this publication. The mechanical design has been optimised for maximum ease & versatility of surface mounting, and maximum longterm reliability in the application. It will provide the minimum cost of ownership to the Original Equipment Manufacturer when initial purchase costs, handling costs and final assembly costs are added together.

The three legs and the heatsink tab emerge sideways from the edge of the plastic body, where they are formed to bring them into contact with the PCB for soldering to the pads. The centre leg and the larger heatsink tab on the opposite side of the package are internally connected.

Because the main tab and the three legs emerge from the edge of the plastic package and are formed before they make contact with the PCB, a certain degree of safe movement of the PCB relative to the device is possible as the assembly expands and contracts during soldering and during circuit operation. Since the device's diepad is not in direct and intimate contact with the PCB solder pad, differential movement caused by different coefficients of expansion can be accommodated without excessive fatigue stress to the solder joints. The more extreme condition of stresses being transmitted to the die, causing it to crack, is also minimised with this package design.

SOT223 soldering

When soldering most SMT power packages, a reflow process must be used. However, for SOT223, it is also feasible to use wave soldering if required. Wave soldering is possible because the small size of the package minimises the size of the "shadow" on the downstream side of the solder flow. Perhaps more importantly, the exposed nature of the solder connections around the periphery of the package, and their relatively low thermal capacities, mean that

full solder wetting is easily possible with wave soldering. The good visibility of the solder joints allows full inspection for quality after assembly.

Figures 2 and 3 show the recommended SOT223 footprints for reflow soldering and for wave soldering.

Plastic surface mounted package; collector pad for good heat transfer; 4 leads

SOT223

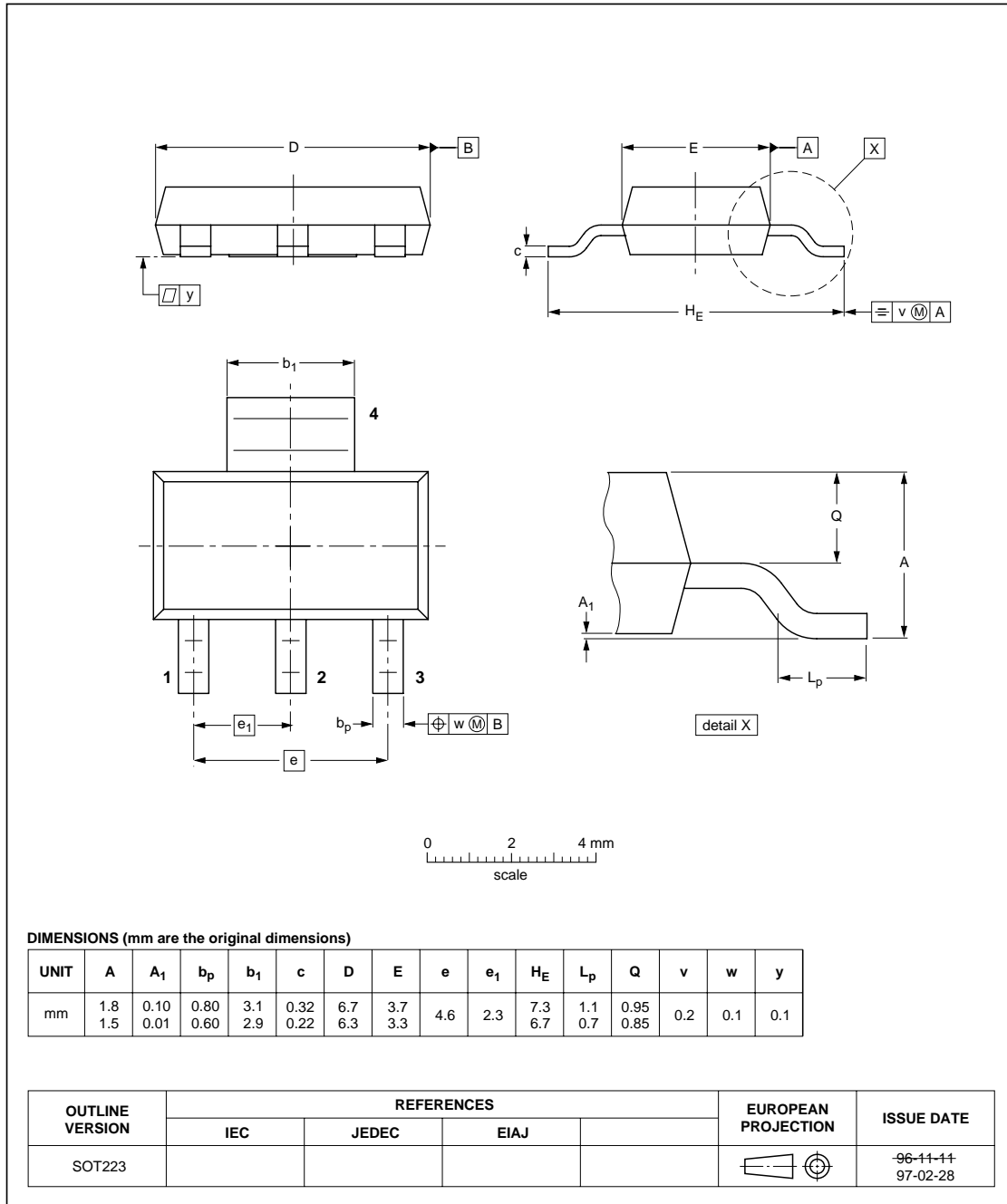

Fig. 1. SOT223.

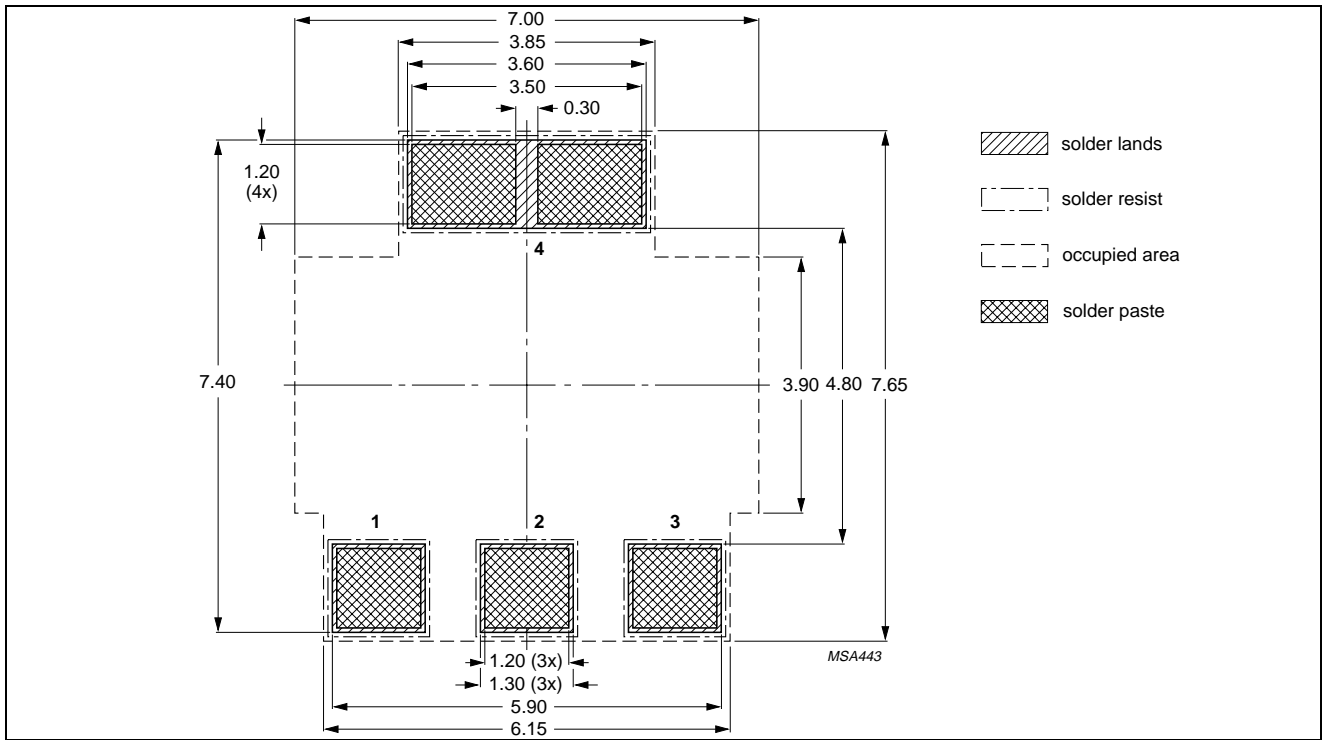

Fig. 2. Reflow soldering footprint for SOT223.

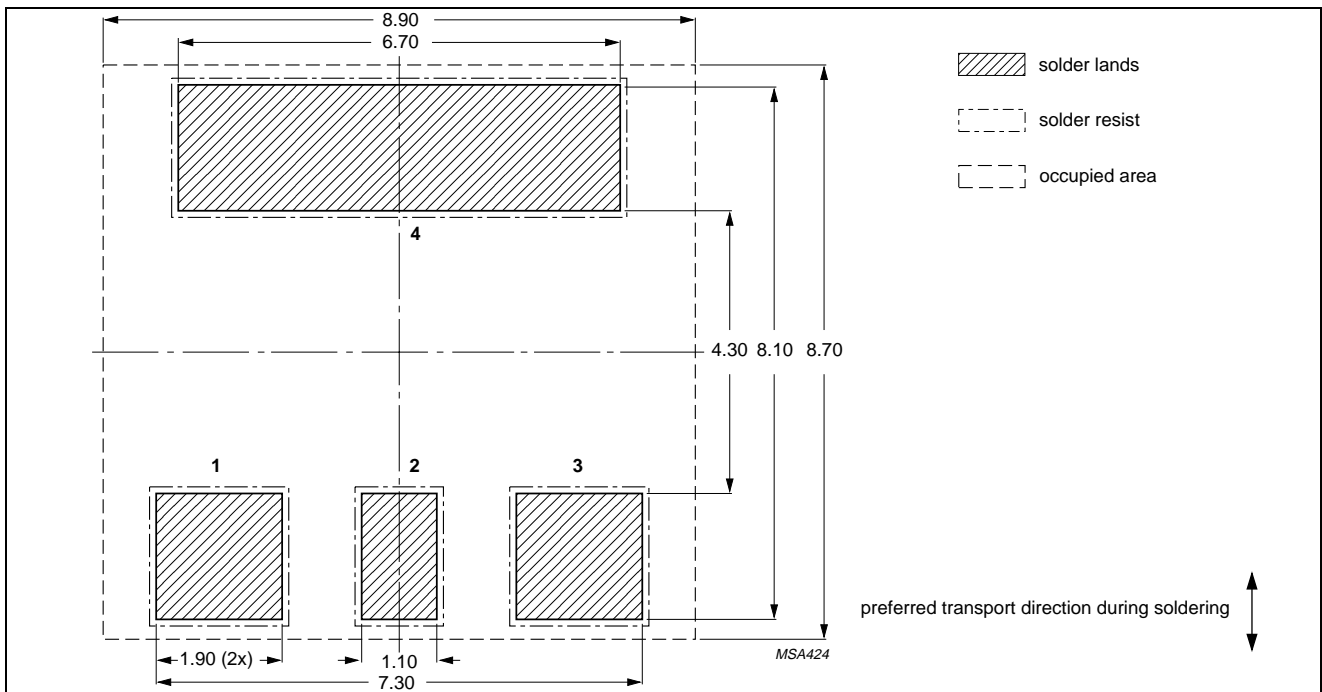

Fig. 3. Wave soldering footprint for SOT223.

SOT428

SOT428 (also known as TO252 and DPAK) occupies an area on the PCB which is not much larger than the area required for SOT223. Indeed, it can be soldered to a universal SOT223 / SOT428 pad layout. Figures 5 and 6 show the pad and relative component sizes. The main pad area of 20mm² is the minimum practical pad size for SOT428.

SOT428 has three legs which emerge from one edge of the plastic body. The centre leg is cropped off close to the plastic, so it is not used for electrical connection. The “centre leg connection” is made from the device’s metal backplate to the main PCB pad. The two outer legs are formed to bring them into contact with the PCB pads for soldering.

Plastic surface mounted package (Philips version of D-PAK); 2 leads

SOT428

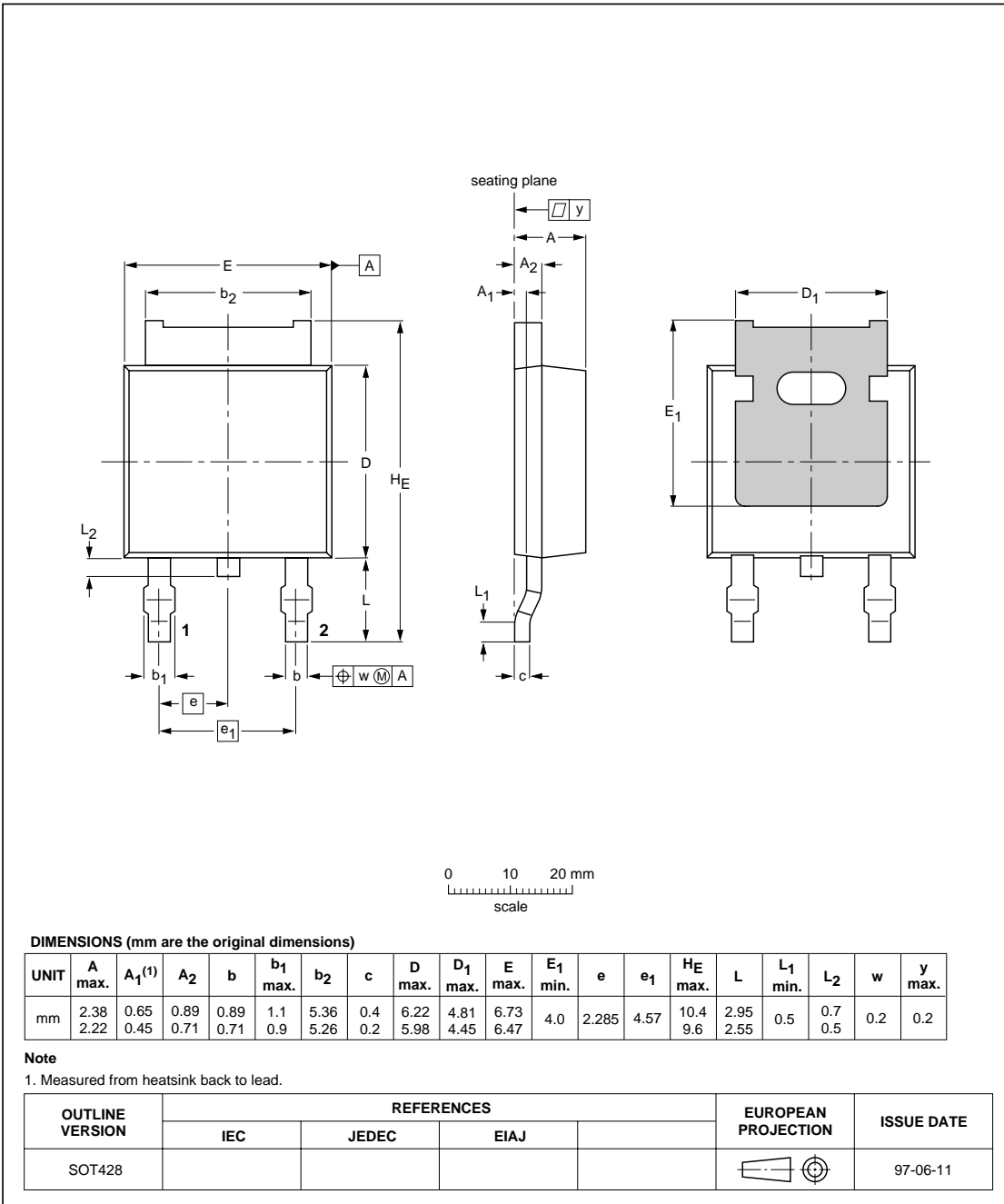

Fig. 4. SOT428.

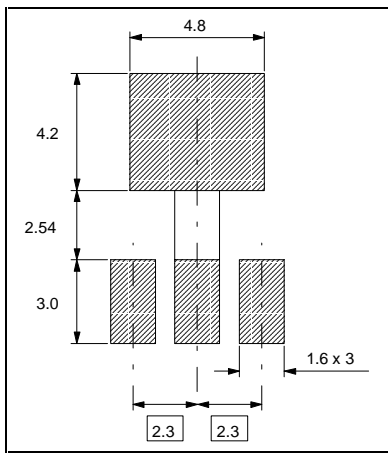

Fig. 5. Universal SOT223 / SOT428 pad layout.

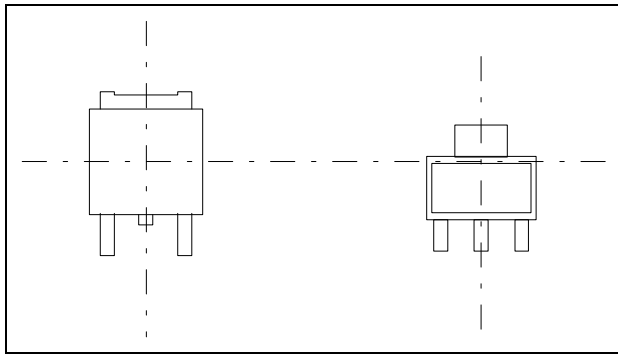

Fig. 6. SOT428 & SOT223 relative sizes.

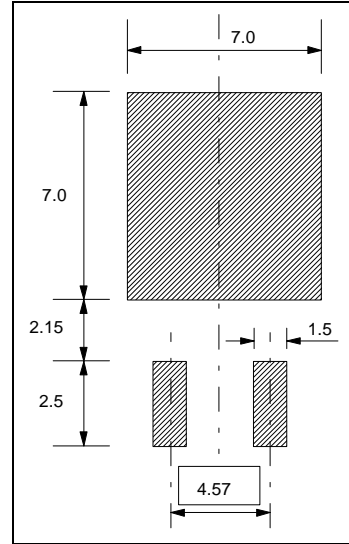

Fig. 7. SOT428 solder pad dimensions.

or during prolonged thermal cycling in the application.

Philips Semiconductors has spent a long time perfecting its SOT428 package before releasing it onto the market so that these pitfalls can be avoided. Described below are some of the special design features which ensure successful manufacture and longterm reliable operation in the customer's application.

SOT428 soldering

This surface mount package features a relatively large solder area (compared to SOT223) which is hidden after assembly. Because the mating surfaces between the main PCB pad and the device are remote from the outside world, wave soldering cannot be relied upon to wet the joint sufficiently. It is therefore necessary to use a reflow soldering method for packages of this design. Figure 7 shows the SOT428 solder pad dimensions.

SOT428 design features for surface mountability

It is well known among power semiconductor manufacturers that the larger a surface mounted power semiconductor is, the more vulnerable it is to die stresses during manufacture and during the surface mounting process. This can result in a significant percentage of rejects due to die cracking. We have learned long ago that it is not possible to use the same manufacturing techniques for surface mount devices as are used for through-hole devices. Unacceptable failure rates will certainly be the result, either during manufacture, during surface mounting

1. The package is moulded using a low stress epoxy plastic in order to minimise the bending force on the mounting base as curing takes place. Less bending of the mounting base means less die stress.
2. A thick copper mounting base of 0.89mm (0.035 inches) max thickness is used to further inhibit any tendency for bending of the mounting base.
3. A low stress, high lead content soft solder is used for diebonding. The amount of "give" in the solder accommodates differential expansions and minimises die stress.
4. A new technique has been developed to accurately control the thickness and positioning of the die-attach solder on the diepad. This guarantees optimum diebonding over the complete die area every time without unsoldered areas or excess solder. The benefit of this is to offer the best longterm reliability under thermal stress and the minimum junction-to-mounting base thermal resistance.

5. Special locking features are used to lock the epoxy to the metal to improve hermeticity. These features have been carefully optimised to provide good hermeticity without locking the epoxy too rigidly to the diepad, which can result in excess die stress during differential expansion.
6. A bare copper diepad is used for best adhesion of the epoxy to the metal. This promotes good hermeticity.
7. All mating surfaces to be soldered to the PCB pads are tin-lead solder plated for good solderability.
8. The footprint is compatible with JEDEC and Motorola layouts.
9. The coplanarity of leads to seating plane and leads to leads meets stringent industry standards.
10. A fully automatic high volume production line is used which takes in the raw components at its input and delivers assembled, 100% tested, packaged devices at its output.
11. All assembled devices are subjected to an in-line surface mount temperature profile pass to eliminate any remaining possibility, however small, of zero hour defects at the customer.
12. Devices are packaged in industry standard blister pack reels for loading onto automatic pick-and-place machines.

SOT404

SOT404 (Fig. 9, also known as TO263 and D²PAK) possesses the same size of plastic body as SOT78 (TO220). The similarity ends there. SOT404 is manufactured without a tab since no mounting hole is required. (It is not merely a cropped TO220!) The centre lead is cropped close to the plastic, so the “centre leg connection” is made via the metal backplate. The two outer leads are formed downwards to bring them into contact with the PCB.

SOT404 soldering

As for SOT428, it is also not possible to solder SOT404 using a wave soldering technique. The even larger body and larger hidden solder area would put this method out of the question. Reflow soldering is essential. Figure 8 shows the SOT404 solder pad dimensions.

SOT404 design features for surface mountability

In designing and manufacturing the SOT404 package, similar measures must be taken as for SOT428 to ensure a reliable end product. These include:

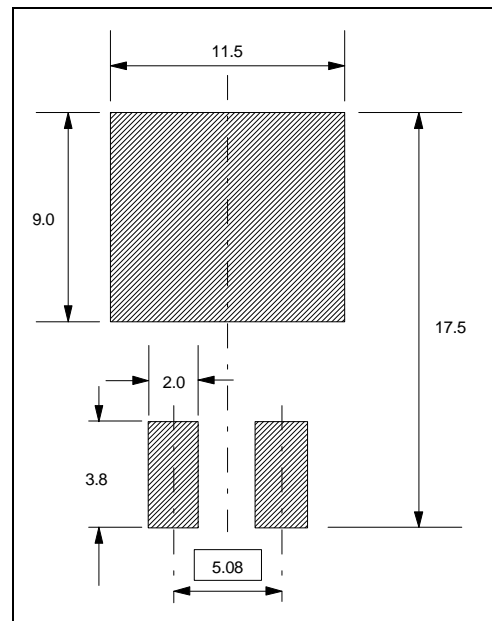

Fig. 8. SOT404 solder pad dimensions.

1. A low stress epoxy to minimise bending forces on the mounting base after curing. (Minimises die stress.)
2. A thick copper mounting base of 1.4mm (0.055 inches) max thickness to further minimise any tendency to bend.
3. A low stress, high lead content soft diebond solder. (Minimises die stress.)
4. Accurate dosing and spreading of the die-attach solder prior to diebonding to ensure optimum diebonding over the complete die area every time without unsoldered areas or excess solder. This offers best longterm reliability under thermal cycling and optimum junction-to-mounting base thermal resistance.
5. Optimised locking features to balance the conflicting requirements of good hermeticity with sufficient differential movement to avoid die stress fracture.
6. A bare copper comb to ensure good epoxy-to-metal adhesion for best hermeticity.
7. Tin-lead solder plating of all exposed copper, including all cropped edges, for optimum solderability.
8. Compatibility with the industry standard footprint layout for D²PAK.
9. Coplanarity check on leads to seating plane and leads to leads.

10.A specially designed leadframe to reduce cropping forces as each device is separated from the comb. This avoids die cracking due to shock loading.

11.A surface mount temperature profile pass to eliminate zero hour defects at the customer.

12.Devices are packaged in industry standard blister pack reels for loading onto automatic pick-and-place machines.

Plastic single-ended package (Philips version of D2-PAK); 2 leads

SOT404

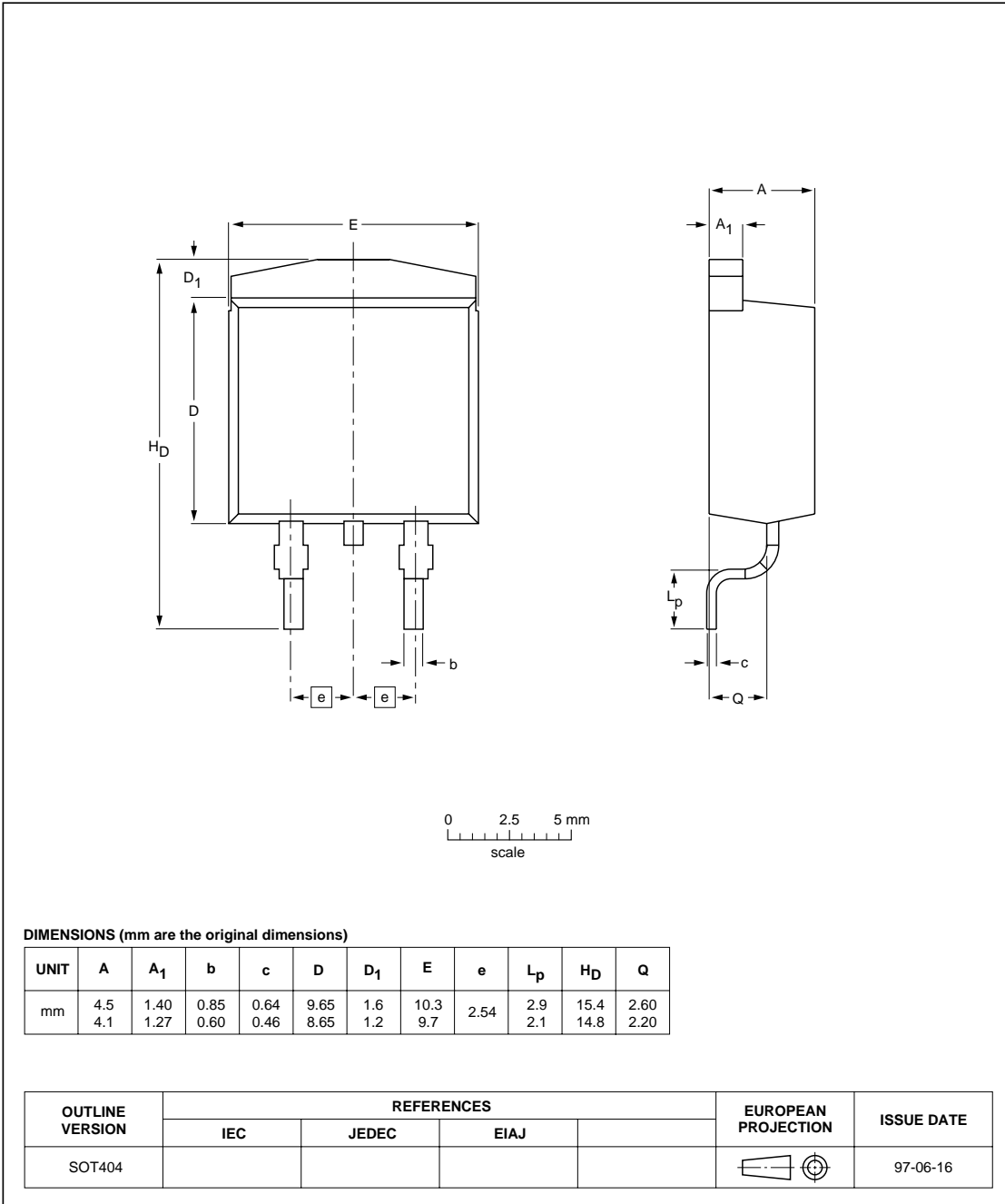

Fig. 9. SOT404.

Mounting and soldering

The SM footprint drawings define the solder land (pad) areas, the solder resist areas and the area occupied by the package. Since the solder lands must be completely free of solder resist, the areas without the solder resist are always slightly greater than the solder land areas. The solder resist must cover all areas of the PCB that are not soldered to. This includes extended areas of copper used for heatsinking.

The footprints for reflow soldering define the solder paste areas in addition to the areas listed above. Solder paste is applied using a metal stencil which must be accurately aligned to within 0.1mm over the pads. A metal "squeegee" is drawn across the stencil to deposit the paste through the apertures, which must be the same size as the solder paste areas defined on the footprint drawings. With reference to Figs. 2 & 3, it can be seen that the optimum pad areas are different for wave soldering and for reflow soldering.

When wave soldering, surface mount devices must be held in position by a small measured dose of adhesive. A double wave process is used to ensure better wetting of all joints without solder shadows. Wave soldering **must** be used if there are any through-hole components on the PCB.

For reflow soldering, surface mount devices are held in position by the viscosity of the solder paste. When the solder is melted in the reflow oven, the surface tension of the molten solder causes them to self centre on their pads. For self centring to operate reliably, the pad sizes and configuration are critical.

For PCBs which contain a mixture of SM and through-hole components, both soldering methods are sometimes employed in order to ensure optimum soldering of both technologies.

A more detailed description of the wave and reflow soldering processes is beyond the scope of this Technical Publication. For a more detailed description, please see Data Handbook SC18 entitled SMD Footprint Design and Soldering Guidelines.

Thermal resistance - a laboratory investigation.

Detailed laboratory tests have been conducted on the junction-to-ambient thermal resistance $R_{th\ j-a}$ of the SOT223, SOT428 and SOT404 SM packages when mounted to different pad sizes on standard FR4 PCB. Sufficient time was devoted to this work to ensure repeatability of the results and to give a high level of confidence in their validity.

Theory

It is possible to measure the temperature of a power semiconductor junction by measuring one of its temperature-dependent characteristics. For example, for a MOSFET it might be the forward voltage of the anti-parallel diode and for a thyristor it would be the forward voltage drop V_T . In order to heat up the device under test, a heating current is passed through it. When measuring its temperature-dependent characteristic, a much lower calibration current is passed for a very short measurement period. For this investigation, thyristors were used because of the relative ease of their measurement and because they were freely available in all the packages of interest.

The size of the die within any given package will not affect the final $R_{th\ j-a}$ result appreciably because any differences in the junction-to-case thermal resistance $R_{th\ j-c}$ will pale into insignificance compared to the

case-to-ambient thermal resistance $R_{th\ c-a}$. It is not critical, therefore, which device is used when measuring package R_{th} in free air or when surface mounted to conventional PCBs with relatively high thermal resistances to ambient.

FR4 fibreglass pcb with 35 μ m copper (1oz/square foot) was used because it is an industry standard to which everyone can relate. It is the PCB type which is always quoted in power semiconductor manufacturers' data sheets. It has become a "reference standard" by default. Despite this "standard" status, many industries cannot justify its use because of its cost. The home appliance industry prefers to use a lower cost alternative, one example of which is CEM3. This is a resin and paper-based material with fibre on both sides. Fortunately, the thermal performance of the cheaper alternatives is sufficiently close to that of FR4 in many cases to make the results of this investigation valid for those also.

Equipment

The test PCBs had pad sizes which varied upwards from the minimum recommended for the package. Consistent pad width / height ratios were maintained. The pad was always positioned centrally on the test board to assure consistent heatsinking to the bulk of

the PCB. SOT223 and SOT428 used the same pad layouts, while SOT404 had its own PCBs. Figure 10 shows the second smallest and largest pad size test boards for SOT223 / SOT428, and Fig. 11 shows the

smallest and largest pad size test boards for SOT404. Note that these test boards are not shown full scale.

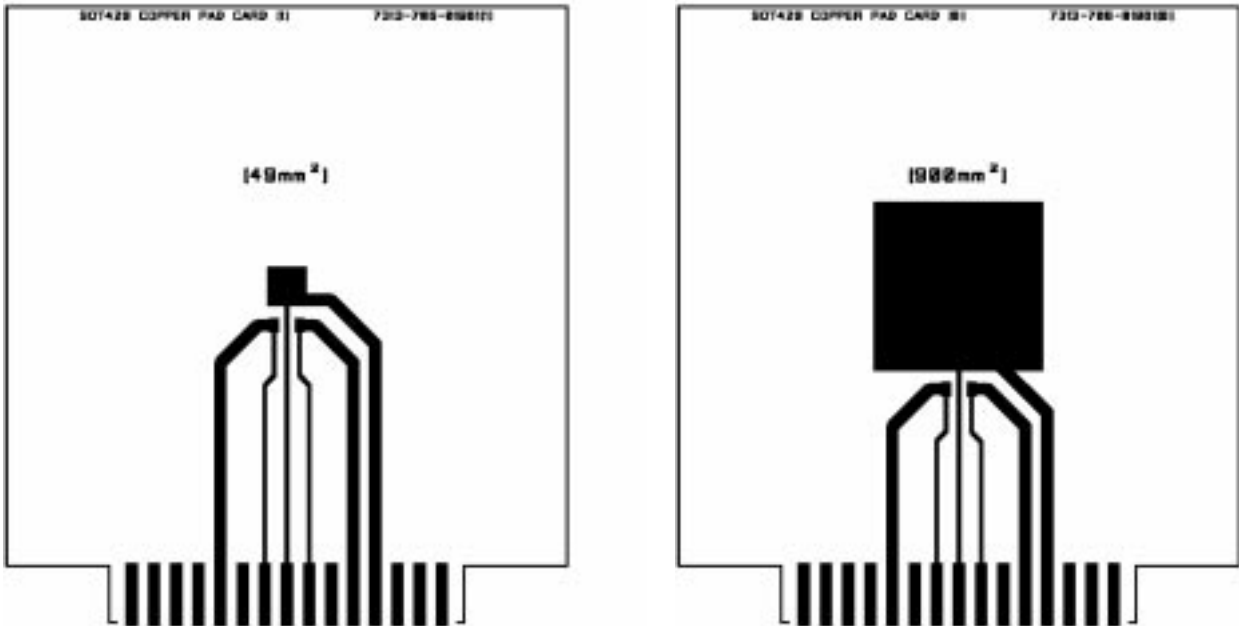

Fig. 10. SOT223 / SOT428 test PCB layout, small and large pad areas.

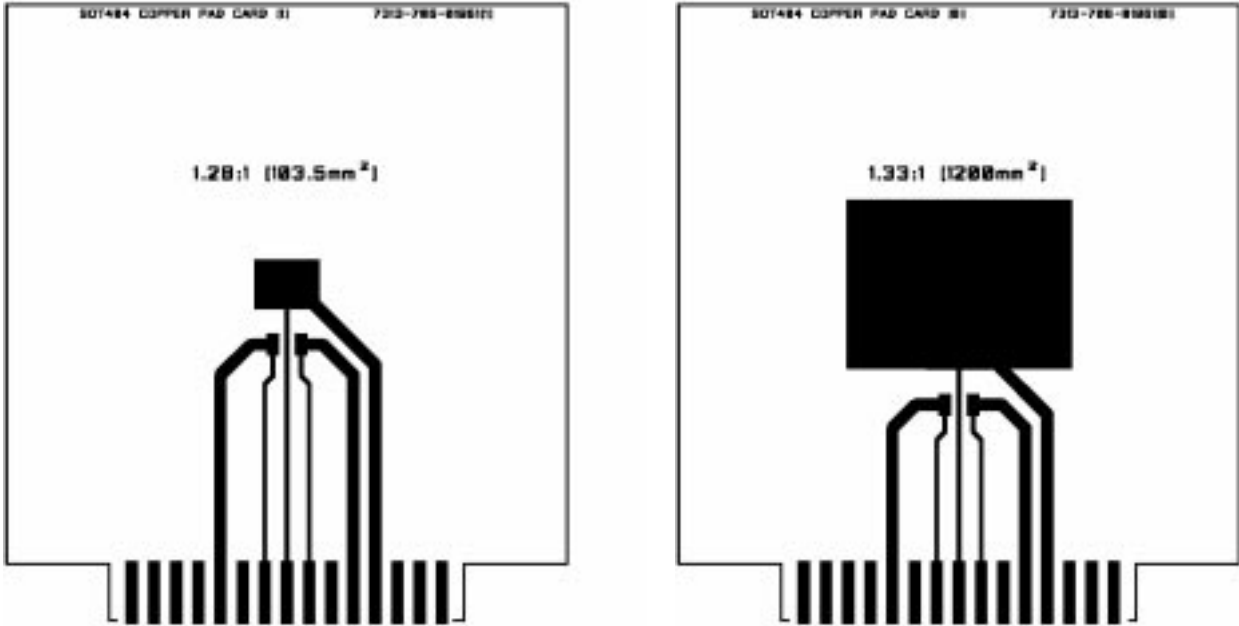

Fig. 11. SOT404 test PCB layout, small and large pad areas.

Separate power and measurement connections were taken via an edge connector to the device. The PCBs were standard fibreglass FR4 with 35µm

copper which had been very lightly “tinned” by electrochemical deposition. (Thermal resistance will not be reduced by a thick layer of roller tinning!) The

PCBs were made relatively large at 100mm x 100mm to ensure that R_{th} is controlled by pad area and not by PCB area.

Thyristors were tested using a purpose built thermal resistance test gear. (Thyristors were tested in preference to triacs because they only require one measurement for each power setting, whereas triacs need measuring in both directions with the average power being calculated from the results.)

The most important fact to remember when conducting the tests was that they take a lot of time. It was essential to ensure that thermal equilibrium and stability had been reached before readings were taken at elevated device temperature. Rushing the tests would give incorrect results and improbable graphs. This was learned from experience.

Results

The resolution and accuracy of the final $R_{th\ j-a}$ results were maximised by generating high values of ΔT_j , hence large measured ΔV . The results tables show

SOT223

Area (mm ²)	0.5W	1.0W*	1.5W
20	110	110	-
49	99	98	-
81	91	90	90
144	88	87	86
256	78	79	78
484	73	74	73
900	68	69	69

$R_{th\ j-a}$ (K/W) versus power dissipation and pad area. The power levels highlighted by an asterisk indicate a suggested power dissipation limit for the package when soldered to the minimum pad area on FR4 PCB. (In the case of the SOT223 package, the smallest pad area used was 20mm². This area is fully occupied by the SOT428 package. The minimum for SOT223 is actually 5.7mm². Therefore the 1W power dissipation achieved in these experiments will be higher than that achievable with a 5.7mm² pad. 0.5W is likely to be a practical maximum power dissipation for SOT223 on a 5.7mm² pad.)

The results graphs show $R_{th\ j-a}$ versus pad area and ΔT_j versus pad area. For any given package, higher power dissipation leads to higher ΔT_j which leads to lower $R_{th\ j-a}$. This is because a larger temperature difference results in more efficient radiation to ambient.

SOT223 Rth j-a vs PCB pad area. 100 x 100 mm FR4 PCB positioned vertically in still air.

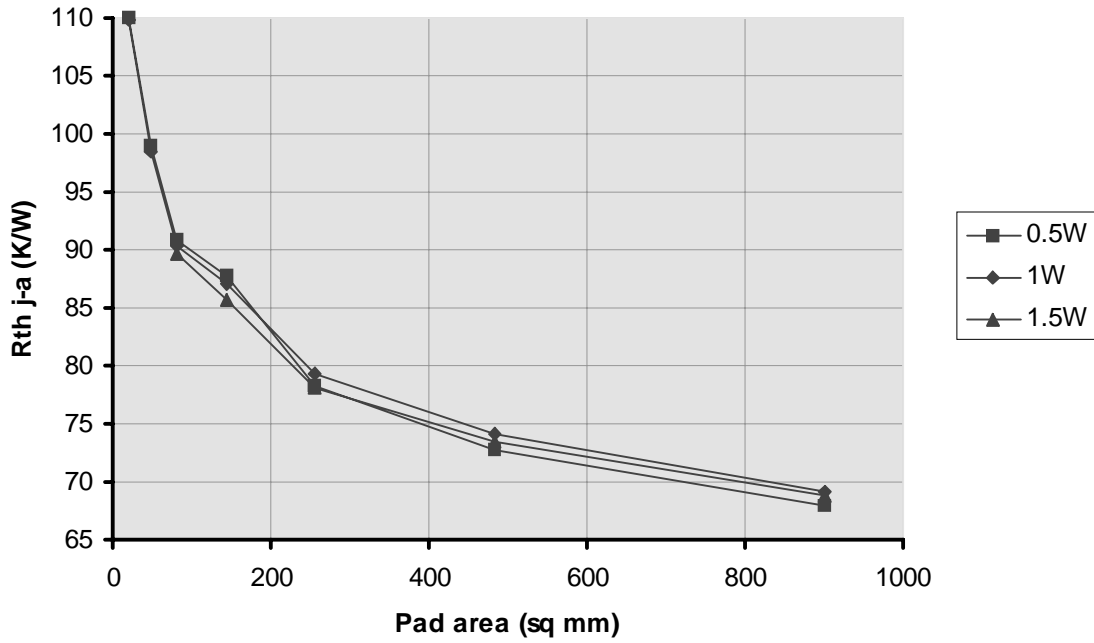

SOT223 Tj rise vs PCB pad area. 100 x 100mm FR4 PCB positioned vertically in still air.

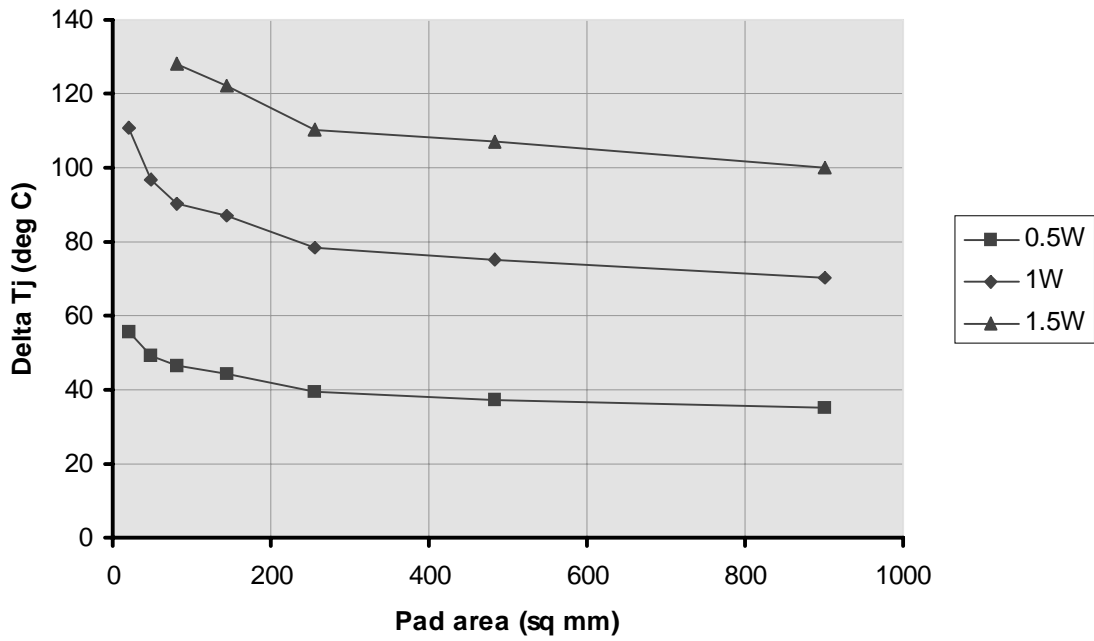

SOT428

Area (mm ²)	0.5W	1.0W*	1.5W*	2.0W	2.5W	3.0W
20	90	85	-	-	-	-
49	77	75	73	72	-	-
81	71	69	66	65	-	-
144	64	62	60	59	58	-
256	58	56	54	53	52	-
484	54	50	48	47	46	45
900	46	45	43	43	42	41

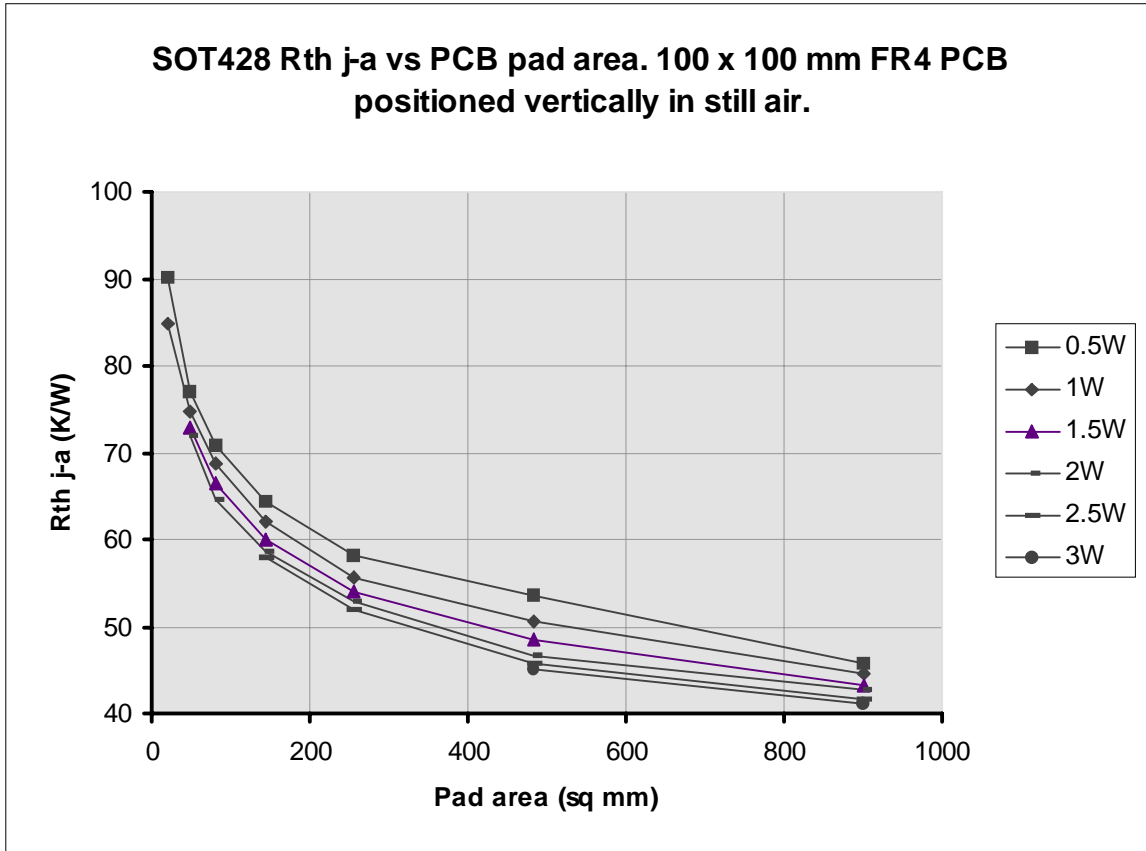

**SOT428 Tj rise vs PCB pad area. 100 x 100mm FR4 PCB
positioned vertically in still air.**

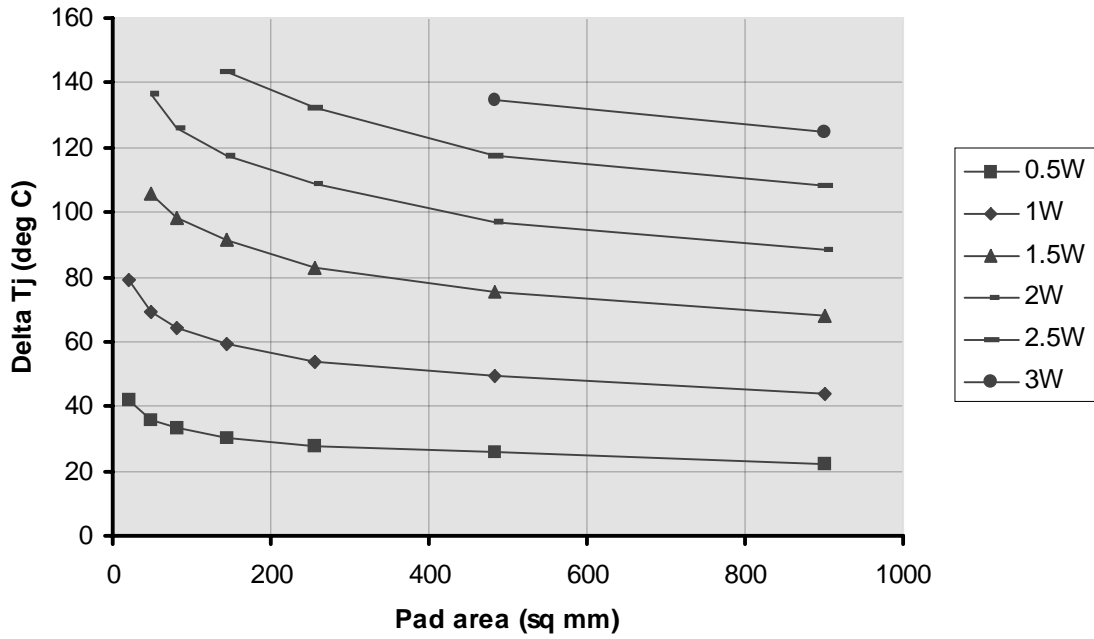

SOT404

Area (mm ²)	1.0W	2.0W*	3.0W
103.5	60	55	-
192	52	47	-
300	47	43	41
475	41	39	37
825	39	36	34
1200	36	34	32

SOT404 Rth j-a vs PCB pad area. 100 x 100mm FR4 PCB positioned vertically in still air.

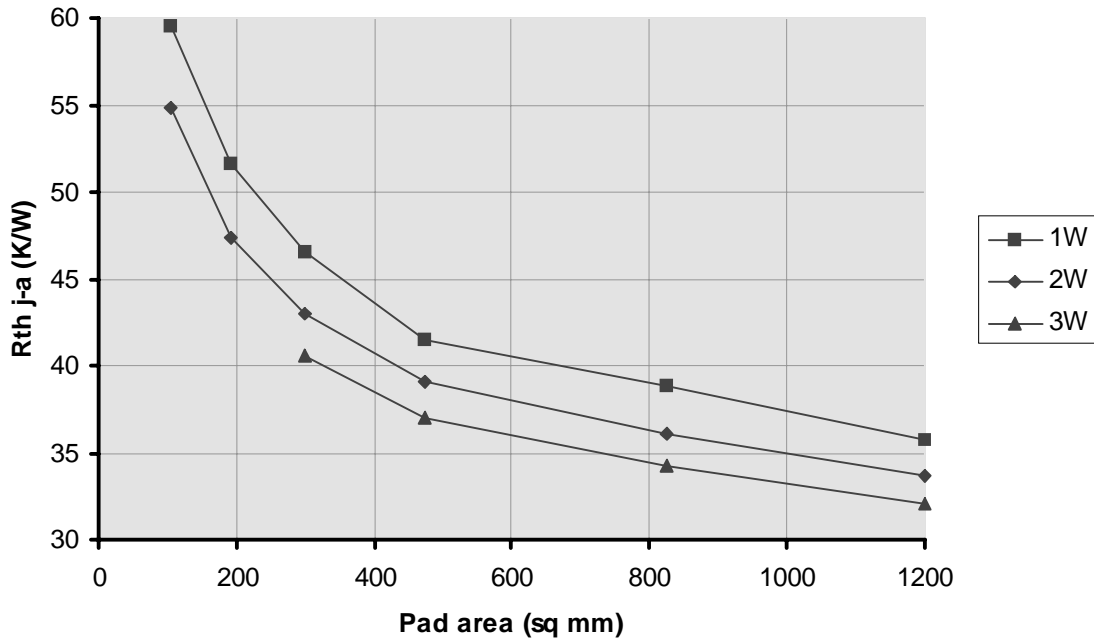

SOT404 Tj vs PCB pad area. 100 x 100mm FR4 PCB positioned vertically in still air.

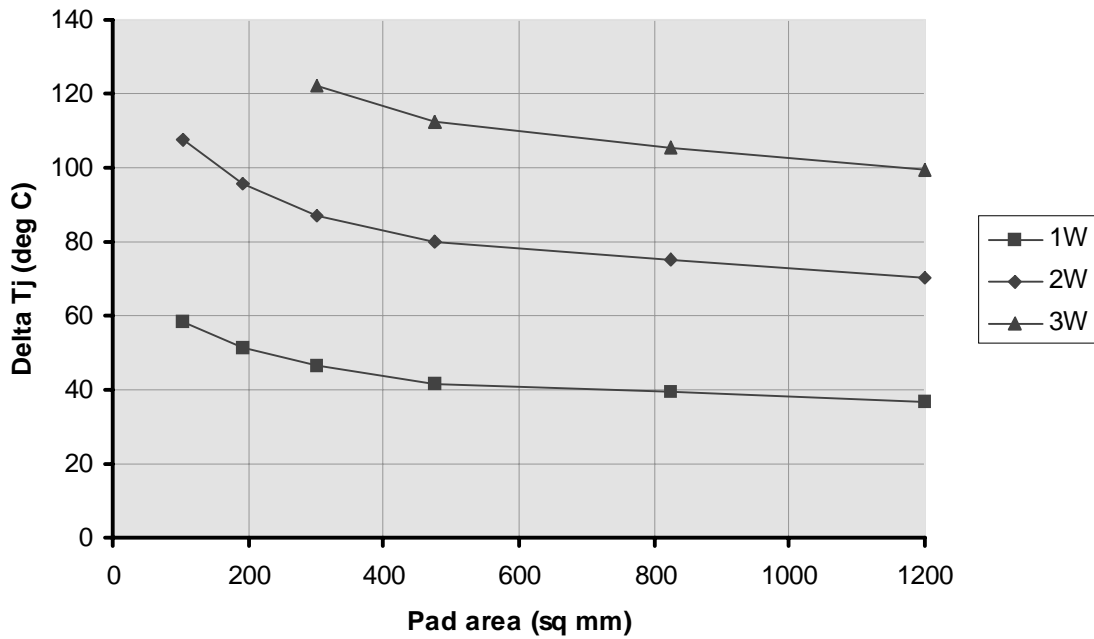

Conclusions

The maximum practical power dissipations are summarised below for stagnant ambient conditions at 25°C. These are for standard FR4 PCB or similar without special heatsinking provisions. The 35µm copper had been lightly tinned by electrochemical deposition.

SOT223 and SOT428 can be soldered to common pad layouts. 20mm² was the absolute minimum pad area for soldering SOT428. A reasonable power dissipation for SOT428 on 20mm² fell somewhere between 1.0W and 1.5W.

The minimum pad quoted in data for SOT223 is 5.7mm². 0.5W is a more realistic maximum power dissipation for SOT223 on its minimum pad.

Package	Pmax (W)	Pad area (mm ²)	ΔT _j (°C)	R _{th j-a} (K/W) (experimental)	R _{th j-a} (K/W) (quoted in data)
SOT223	1.0	20	97	99	156 (5.7mm ² pad)
		650	74	72	70 (648mm ² pad)
SOT428	1.0<1.5	20	106	73	75
SOT404	2.0	104	108	55	55

Naked dice

All Philips' thyristors and triacs can be supplied as naked dice if required. Please contact your local sales office for details.

SUNSTAR 商斯达实业集团是集研发、生产、工程、销售、代理经销、技术咨询、信息服务等为一体的高科技企业，是专业高科技电子产品生产厂家，是具有 10 多年历史的专业电子元器件供应商，是中国最早和最大的仓储式连锁规模经营大型综合电子零部件代理分销商之一，是一家专业代理和分销世界各大品牌 IC 芯片和电子元器件的连锁经营综合性国际公司，专业经营进口、国产名厂名牌电子元件，型号、种类齐全。在香港、北京、深圳、上海、西安、成都等全国主要电子市场设有直属分公司和产品展示展销窗口门市部专卖店及代理分销商，已在全国范围内建成强大统一的供货和代理分销网络。我们专业代理经销、开发生产电子元器件、集成电路、传感器、微波光电元器件、工控机/DOC/DOM 电子盘、专用电路、单片机开发、MCU/DSP/ARM/FPGA 软件硬件、二极管、三极管、模块等，是您可靠的一站式现货配套供应商、方案提供商、部件功能模块开发配套商。商斯达实业公司拥有庞大的资料库，有数位毕业于著名高校——有中国电子工业摇篮之称的西安电子科技大学（西军电）并长期从事国防尖端科技研究的高级工程师为您精挑细选、量身订做各种高科技电子元器件，并解决各种技术问题。

微波光电部专业代理经销高频、微波、光纤、光电元器件、组件、部件、模块、整机；电磁兼容元器件、材料、设备；微波 CAD、EDA 软件、开发测试仿真工具；微波、光纤仪器仪表。欢迎国外高科技微波、光纤厂商将优秀产品介绍到中国、共同开拓市场。长期大量现货专业批发高频、微波、卫星、光纤、电视、CATV 器件：晶振、VCO、连接器、PIN 开关、变容二极管、开关二极管、低噪晶体管、功率电阻及电容、放大器、功率管、MMIC、混频器、耦合器、功分器、振荡器、合成器、衰减器、滤波器、隔离器、环行器、移相器、调制解调器；光电子器件和组件：红外发射管、红外接收管、光电开关、光敏管、发光二极管和发光二极管组件、半导体激光二极管和激光器组件、光电探测器和光接收组件、光发射接收模块、光纤激光器和光放大器、光调制器、光开关、DWDM 用光发射和接收器件、用户接入系统光收发器件与模块、光纤连接器、光纤跳线/尾纤、光衰减器、光纤适配器、光隔离器、光耦合器、光环行器、光复用器/转换器；无线收发芯片和模组、蓝牙芯片和模组。

更多产品请看本公司产品专用销售网站：

商斯达中国传感器科技信息网：<http://www.sensor-ic.com/>

商斯达工控安防网：<http://www.pc-ps.net/>

商斯达电子元器件网：<http://www.sunstare.com/>

商斯达微波光电产品网：[HTTP://www.rfoe.net/](http://www.rfoe.net/)

商斯达消费电子产品网：<http://www.icasic.com/>

商斯达实业科技产品网：<http://www.sunstars.cn/> 微波元器件销售热线：

地址：深圳市福田区福华路福庆街鸿图大厦 1602 室

电话：0755-82884100 83397033 83396822 83398585

传真：0755-83376182 (0) 13823648918 MSN: SUNS8888@hotmail.com

邮编：518033 E-mail:szss20@163.com QQ: 195847376

深圳赛格展销部：深圳华强北路赛格电子市场 2583 号 电话：0755-83665529 25059422

技术支持：0755-83394033 13501568376

欢迎索取免费详细资料、设计指南和光盘；产品凡多，未能尽录，欢迎来电查询。

北京分公司：北京海淀区知春路 132 号中发电子大厦 3097 号

TEL: 010-81159046 82615020 13501189838 FAX: 010-62543996

上海分公司：上海市北京东路 668 号上海赛格电子市场 D125 号

TEL: 021-28311762 56703037 13701955389 FAX: 021-56703037

西安分公司：西安高新开发区 20 所(中国电子科技集团导航技术研究所)

西安劳动南路 88 号电子商城二楼 D23 号

TEL: 029-81022619 13072977981 FAX:029-88789382